

Soft-Starter

SSW900

User's Manual

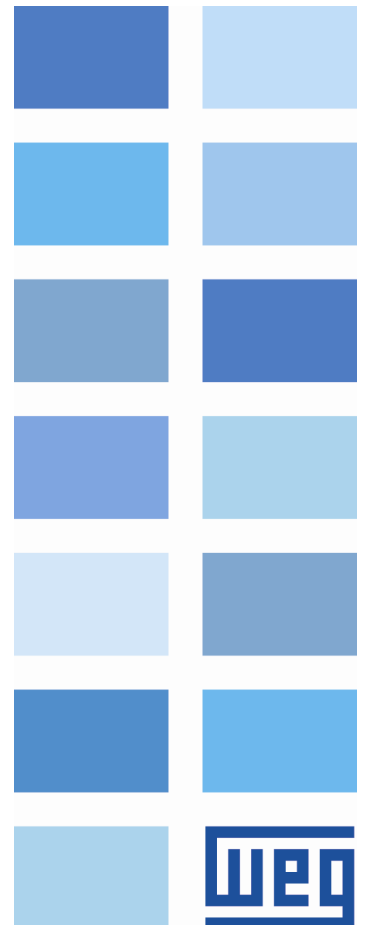



User's Manual

Series: SSW900

Language: English

Document: 10005616165 / 10

Publication Date: 09/2022

The information below describes the revisions made to this manual.

Version	Revision	Description
-	R00	First edition
-	R01	General revision
-	R02	General revision
-	R02	General revision
-	R03	General revision
-	R04	Inclusion of the frame E
-	R05	Inclusion of the frames F and G and general revision
-	R06	Inclusion of the 690 V line and general revision
-	R07	General revision
-	R08	Fuses UL
-	R09	General revision
-	R10	Table 3.3, UL delta inside and general revision

1	SAFETY INSTRUCTIONS	1
1.1.	SAFETY NOTICES IN THE MANUAL	1
1.2.	SAFETY NOTICES ON THE PRODUCT	1
1.3.	PRELIMINARY RECOMMENDATIONS	2
2	GENERAL INFORMATION	3
2.1.	ABOUT THIS MANUAL	3
2.2.	ABOUT THE SSW900	4
2.3.	SOFT-STARTER SSW900 IDENTIFICATION	4
2.4.	HOW TO SPECIFY THE SSW900 MODEL (SMART CODE)	5
2.5.	RECEIVING AND STORAGE	6
3	INSTALLATION AND CONNECTION	7
3.1.	MECHANICAL INSTALLATION	7
3.1.1.	Environmental Conditions	7
3.1.2.	Soft-Starter SSW900 Dimensions	7
3.1.3.	Mounting Specifications	8
3.1.4.	Mounting on a Panel	9
3.1.5.	Mounting on a Surface	11
3.2.	ELECTRICAL INSTALLATION	11
3.2.1.	Power Terminals	11
3.2.2.	Recommended Power and Grounding Cables - IEC	16
3.2.3.	Recommended Power and Grounding Cables - UL	17
3.2.4.	SSW900 - Power supply connection	19
3.2.5.	Short Circuit Capacity – Tested at UL	19
3.2.6.	Input Circuit Breakers and Fuses- IEC	23
3.2.7.	Main Input Contactor or Circuit Breaker	28
3.2.8.	Bypass Contactor	28
3.2.9.	Connection of the SSW900 to the motor	28
3.2.10.	Standard Three-Wire Connection of the SSW900 to the Motor	30
3.2.11.	Connection of the SSW900 Inside Delta Motor Connection Six-Cable	30
3.2.12.	Grounding Connections	32
3.2.13.	User's Signal and Control Connections	33
3.3.	INSTALLATION IN COMPLIANCE WITH STANDARD EN60947-4-2	37
3.4.	RECOMMENDED SET-UPS	37
3.4.1.	Commands via HMI and Power Isolation Contactor	38
3.4.2.	Commands via Digital Inputs and Power Isolation Circuit Breaker	39
3.4.3.	Commands via Digital Inputs and Power Isolation Contactor	40
3.4.4.	Commands via Digital Inputs and Inside Delta Motor Connection	41
3.4.5.	Commands via Digital Inputs and External Bypass Contactor	42
3.4.6.	Commands via Digital Inputs, Optimal Braking and DC Braking	43
3.4.7.	Command via Digital Inputs and Reverse Braking	44
3.4.8.	Command via Digital Inputs and Change of Direction of Rotation	45
4	POWER-UP AND START-UP	46
4.1.	POWER-UP PREPARATION	46
4.2.	INITIAL POWER-UP	46
4.3.	START-UP	47
5	TROUBLESHOOTING AND MAINTENANCE	48
5.1.	ACTUATION OF PROTECTIONS, FAULTS AND ALARMS	48
5.2.	FREQUENT PROBLEMS	49
5.3.	PREVENTIVE MAINTENANCE	51
5.4.	ELECTRONICS FUSE REPLACEMENT	52
5.5.	RTC BATTERY REPLACEMENT	52
5.6.	INFORMATION NECESSARY TO CONTACT TECHNICAL SUPPORT	52
6	ACCESSORIES	53
6.1.	SLOT 1 AND 2 ACCESSORIES	53
6.2.	VENTILATION ACCESSORIES	54

6.3.	HMI IN PANEL DOOR ACCESSORIES.....	55
6.4.	HMI BLUETOOTH ACCESSORY	55
6.5.	IP20 ACCESSORIES	56
6.6.	TOUCH PROTECTION ACCESSORIES.....	56
6.7.	POWER BUSBAR ACCESSORIES.....	58
7	TECHNICAL CHARACTERISTICS	61
7.1.	POWER DATA.....	61
7.1.1.	Operation Conditions	61
7.1.2.	Rated Currents According to the Operation Conditions - IEC.....	63
7.1.3.	Rated Currents According to the Operation Conditions - UL	67
7.1.4.	Power Tables for Standardized Duty Cycle.....	67
7.2.	OPERATING RANGE OF POWER.....	70
7.3.	ELECTRONICS DATA	70
7.4.	CONSIDERED STANDARDS	71
7.5.	GROUND INSULATION	71
8	ATTACHMENT	72
8.1.	CHANGING THE BUSBARS OF THE FRAME E, F, G.....	72
8.2.	USING EXTERNAL CONTACTOR IN FRAMES E, F, G.....	76
8.3.	USING BUSBAR ACCESSORIES FOR USA MARKET	77

1 SAFETY INSTRUCTIONS

This manual contains all necessary information for the correct installation and operation of the SSW900.

It was written to be used by qualified personnel with suitable training or technical qualifications to operate this type of equipment.

1.1.SAFETY NOTICES IN THE MANUAL

The following safety notices are used in the manual:

**DANGER!**

The procedures recommended in this warning have the purpose of protecting the user against death, serious injuries and considerable material damage.

**ATTENTION!**

The procedures recommended in this warning have the purpose of avoiding material damage.

**NOTE!**

The information mentioned in this warning is important for the proper understanding and good operation of the product.

1.2.SAFETY NOTICES ON THE PRODUCT

The following symbols may be attached to the product, serving as Safety Notices:



High voltages present.



Components sensitive to electrostatic discharges.
Do not touch them.



Mandatory connection to the protection earth (PE).



Connection of the shield to the ground.

1.3.PRELIMINARY RECOMMENDATIONS

**DANGER!**

Only qualified personnel familiar with the SSW900 and associated equipment should plan or implement the installation, start-up and maintenance of this equipment.

These personnel must follow all the safety instructions included in this manual and/or defined by local regulations.

Failure to follow these safety instructions may result in personnel injury and/or equipment damage.

**NOTES!**

For the purposes of this manual, qualified personnel are those trained to be able to:

1. Install, ground, energize and operate the SSW900 according to this manual and the effective legal safety procedures.
2. Use protective equipment according to the established standards.
3. Give first aid services.

**DANGER!**

Always disconnect the main power supply before touching any electrical component associated with the SSW900.

High voltages and spinning parts (fans) may be present even after switching off the power supply. Wait at least 3 minutes for the complete discharge of the capacitors and until the fans stopped.

Always connect the equipment frame to the protection earth (PE) at the proper connection point.

**ATTENTION!**

All electronic boards have components that are sensitive to electrostatic discharges. Never touch any of the electrical components or connectors without following proper grounding procedures. If necessary to do so, touch the properly grounded metallic frame or use a suitable ground strap.

**Do not apply any high voltage test on the SSW900.
If necessary, contact the manufacturer.**

**NOTE!**

Soft-Starter SSW900 can interfere with other electronic equipment. Follow the measures in Chapter 3 to reduce these effects.

**NOTE!**

Read this manual completely before installing or operating the SSW900.

2 GENERAL INFORMATION

2.1.ABOUT THIS MANUAL

This manual presents the necessary information for the installation and commissioning, as well as the product main technical characteristics, and how to troubleshoot the SSW900 most common problems.

This manual must be used together with the SSW900 programming manual.

**ATTENTION!**

The operation of this equipment requires installation and detailed operational procedures provided in the user's manual, programming manual and communication manuals.

A hard copy of the User's Manual is supplied with the soft-starter SSW900.

The accessories guides are supplied in hard copy with the respective accessory. Other manuals can be gathered in soft copy on WEG's website – www.weg.net

For information on the accessories and operation conditions, refer to the following manuals:

- Modbus RTU communication manual.
- Anybus communication manual specific for the protocol used.

Reproduction of this manual content is prohibited, as a whole or in parts, without written permission from WEG.

2.2.ABOUT THE SSW900

The “Soft-Starter WEG 900” is a high-performance device that allows controlled starts and stops as well as protection for three-phase induction motors. With this feature, the starter mitigates mechanical shocks to the load driven by the motor, current pikes in the power supply line that can affect other electronic equipment and can diminish the lifespan of the induction motor.

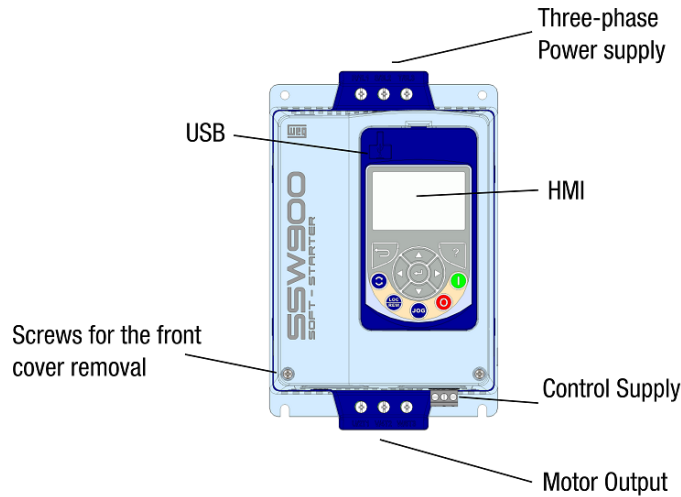

Figure 2.1: Front view of the SSW900

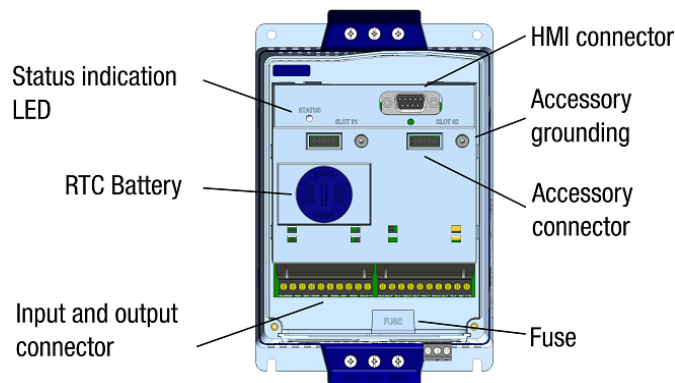

Figure 2.2: Access to the control of the SSW900

2.3.SOFT-STARTER SSW900 IDENTIFICATION



Figure 2.3: Soft-Starter SSW900 identification plate

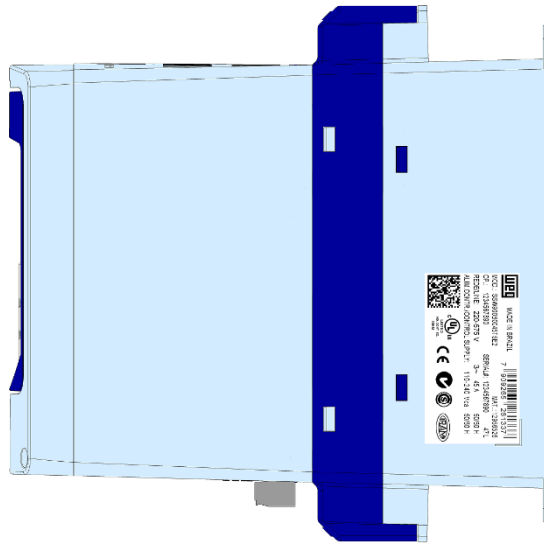

Figure 2.4: Position of the label on the SSW900

2.4.HOW TO SPECIFY THE SSW900 MODEL (SMART CODE)

Table 2.1: Smart code

SSW900	-	----	T_	E_	--	--	-
Soft-starter WEG Series	Frame Size	Rated Current	Power Supply - Three-phase	Control Power Supply	Special hardware	Special software	HMI
SSW900	A	0010 = 10 A 0017 = 17 A 0024 = 24 A 0030 = 30 A	T5 = 220 to 575 V T6 = 380 to 690 V standard connection three cables	E2 = 110 to 240 V	Hx = reserved	Sx = special	_ Standard B = Bluetooth
	B	0045 = 45 A 0061 = 61 A 0085 = 85 A 0105 = 105 A					
	C	0130 = 130 A 0171 = 171 A 0200 = 200 A					
	D	0255 = 255 A 0312 = 312 A 0365 = 365 A 0412 = 412 A	T5 = 220 to 500 V T6 = 380 to 575 V inside delta motor connection six cables	E3 = 110 to 130 V E4 = 220 to 240 V			
	E	0480 = 480 A 0604 = 604 A 0670 = 670 A					
	F	0820 = 820 A 0950 = 950 A					
	G	1100 = 1100 A 1400 = 1400 A					

Example:

SSW900A0017T5E2

Soft-starter WEG series: SSW900

Frame size: A

Rated current: 17 A

Three-phase rated voltage of the power: 220 to 575 V

Rated voltage of the electronics: 110 to 240 V

2.5.RECEIVING AND STORAGE

The SSW900 is supplied in a cardboard box.

External to the box there is an identification plate which is identical to the one placed on the Soft-Starter SSW900.

To open the package:

- 1- Place the box on a table;
- 2- Open the box;
- 3- Remove the SSW900.

Check if:

- The Identification plate of the SSW900 matches the model purchased.
- Damage has occurred during transport. If so, contact the carrier immediately.
- When the product is not installed immediately, store it in its package in a clean and dry place with temperature between -25 °C and 65 °C (-13 °F to 149 °F).

Table 2.2: Dimensions of the package in mm (in)

Model SSW900	Frame	Height H mm (in)	Width L mm (in)	Depth P mm (in)	Volume cm ³ (in)	Weight kg (lb)
10 A 17 A 24 A 30 A	A	351 (13.82)	220 (8.66)	300 (11.81)	23166 (1414)	2.58 (5.69)
45 A 61 A 85 A 105 A	B	351 (13.82)	220 (8.66)	300 (11.81)	23166 (1414)	4.67 (10.30)
130 A 171 A 200 A	C	410 (16.14)	263 (10.35)	310 (12.2)	33427 (2040)	7.48 (16.49)
255 A 312 A 365 A 412 A	D	500 (19.69)	296 (11.65)	285 (11.22)	42180 (2574)	14.03 (300.93)
480 A 604 A 670 A	E	580 (22.83)	720 (28.35)	600 (23.62)	250560 (15290)	61.50 (135.58)
820 A 950 A	F	1103 (43.43)	801 (31.54)	724 (28.50)	639656 (39034)	118.40 (261.03)
1100 A 1400 A	G	1244 (48.98)	1054 (41.50)	774 (30.47)	1014850 (61930)	163.20 (359.79)

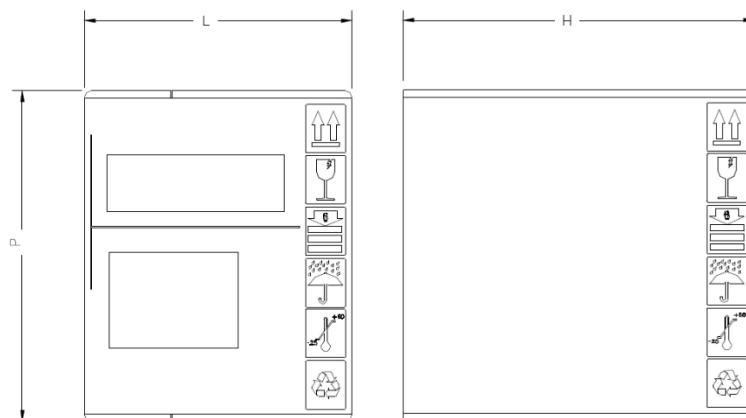

Figure 2.5: Dimensions of the package

3 INSTALLATION AND CONNECTION

This chapter describes the procedures for the electrical and mechanical installation of the Soft-Starter SSW900. The recommendations have to be followed to ensure equipment and people safety as well as the proper operation of the SSW900.

3.1.MECHANICAL INSTALLATION

3.1.1.Environmental Conditions

For the proper operation and expected lifespan of the SSW900, the environmental condition around the starter is a point to consider.

Avoid:

- Direct exposure to sunlight, rain, high moisture and sea air.
- Exposure to explosive or corrosive gases and liquids.
- Excessive vibration.
- Dust or any metallic and/or oil particles in the air.

Allowed Environment Conditions:

- Temperature: -10 °C to 55 °C (32 °F to 131 °F) - nominal conditions (measured under the SSW900).
 -10 °C to 55 °C (14 °F to 131 °F) models up to 412 A;
 -10 °C to 40 °C (14 °F to 104 °F) models over 412 A. From 40°C to 55°C (104°F to 131°F) you may consider a current reduction of 2% for each degree Celsius over 40 °C (104 °F) not exceeding the maximum of 55°C. For additional duty cycles, see item 7 Technical Characteristics;
 - The maximum air temperature below the SSW900 must not be above 55 °C (131 °F), or 40 ° C (104 °F) for models above 412 A when used without current derating.
 Relative air moisture: 5 % to 90 % with no-condensing.
- Maximum altitude: 1000 m (3281 ft) above sea level - nominal conditions.
 From 1000 m to 4000 m (3281 ft to 13123 ft) above sea level – current derating of 1 % for each 100 m (328 ft) above 1000 m (3281 ft).
 From 2000 m to 4000 m (6562 ft to 13123 ft) above sea level – voltage derating of 1.1 % for each 100 m (328 ft) above 2000 m (6562 ft).
- Pollution degree: 3 to line T5 = 220 to 575 V, 2 to line T6 = 380 to 690 V.

3.1.2.Soft-Starter SSW900 Dimensions

The external dimensions and fixing points are shown in Figure 3.1 and Table 3.1 below.

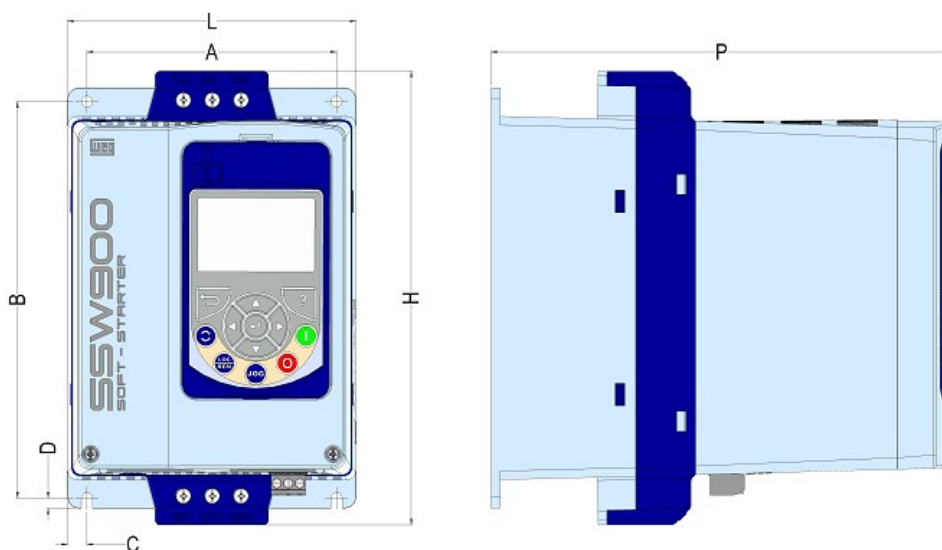

Figure 3.1: SSW900 Dimension

Table 3.1: Data for installation with dimensions in mm (in)

SSW900 Model	Height H mm (in)	Width L mm (in)	Depth P mm (in)	A mm (in)	B mm (in)	C mm (in)	D mm (in)	Mounting Screw	Weight kg (lb)	Degree of Protection
10 A 17 A 24 A 30 A	200 (7.87)	127 (5.00)	203 (7.99)	110 (7.33)	175 (6.89)	8.5 (0.33)	4.3 (0.17)	M4	1.93 (4.25)	IP20
45 A 61 A 85 A 105 A	208 (8.19)	144 (5.67)	260 (10.24)	132 (5.20)	148 (5.83)	6 (0.24)	3.4 (0.13)	M4	4.02 (8.86)	IP20
130 A 171 A 200 A	276 (10.87)	223 (8.78)	261 (10.28)	208 (8.19)	210 (8.27)	7.5 (0.30)	5 (0.20)	M5	6.55 (14.44)	IP00 IP20 (*)
255 A 312 A 365 A 412 A	331 (13.03)	227 (8.94)	282 (11.10)	200 (7.87)	280 (11.02)	15 (0.59)	9 (0.35)	M8	12.83 (28.29)	IP00 IP20 (*)
480 A 604 A 670 A	575 (22.64)	390 (15.35)	260 (10.24)	270 (10.63)	480 (18.90)	56 (2.20)	10 (0.39)	M8	38.00 (83.78)	IP00
820 A 950 A	800 (31.50)	464 (18.27)	316 (12.44)	320 (12.60)	625 (24.61)	72 (2.83)	10 (0.39)	M8	75.40 (166.23)	IP00
1100 A 1400 A	914 (35.98)	539 (21.22)	316 (12.44)	369 (14.53)	732 (28.82)	85 (3.35)	12 (0.47)	M10	107.20 (236.34)	IP00

(*) IP20 with optional kit.

3.1.3. Mounting Specifications

For the proper operation of the SSW900, clearances around the product installed are required as per Table 3.2.

Table 3.2: Recommended clearances

SSW900 Model	Frame	A mm (in)	B mm (in)	C mm (in)
10 A 17 A 24 A 30 A	A	50 (2)	50 (2)	30 (1.2)
45 A 61 A 85 A 105 A	B	80 (3.2)	80 (3.2)	30 (1.2)
130 A 171 A 200 A	C	100 (4)	100 (4)	30 (1.2)
255 A 312 A 365 A 412 A	D	150 (6)	150 (6)	30 (1.2)
480 A 604 A 670 A	E	150 (6)	150 (6)	30 (1.2)
820 A 950 A	F	180 (7.09)	180 (7.09)	30 (1.18)
1100 A 1400 A	G	180 (7.09)	180 (7.09)	30 (1.18)

Install the SSW900 in the vertical position according to the following recommendations:

- 1 - Install it on a reasonably flat surface;
- 2 - The top part of the SSW900 is the exhaustion of hot air. It is not recommended the installation of sensitive to heat components in that area.

ATTENTION!

If you install one SSW900 above the other, use the minimum distance A + B and place the upper SSW900 out of the way of the hot air coming from the lower SSW900.

ATTENTION!

Provide independent conduits or gutters for the physical separation of signal, control, and power cables (Refer to the Section 3.2 Electrical Installation).

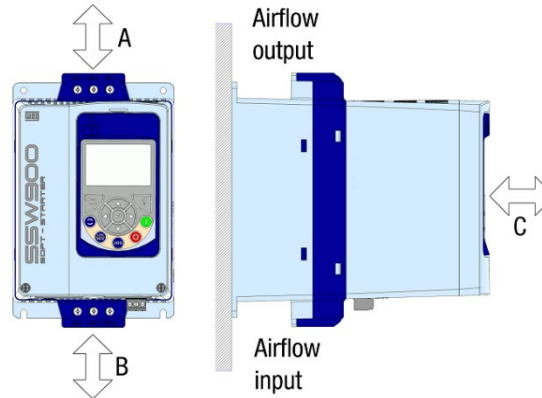

Figure 3.2: Clearances for ventilation

3.1.4. Mounting on a Panel

For SSW900 units installed inside panels or metallic boxes, provide proper exhaustion so that the temperature remains within the allowed range. Refer to the rated dissipated power in the following Table 3.3.

Table 3.3: Dissipated powers for sizing the panel fan

Model SSW900	Power dissipated in the bypass W	Total Power dissipation in one cycle W	Duty Cycle	Maximum Air Temperature Inside Panel
10 A	35	44	10 starts / hour 3 x In @ 30 s	55 °C (131 °F)
17 A	44	63		
24 A	57	85		
30 A	73	111		
45 A	34	78		
61 A	38	106		
85 A	45	129		
105 A	53	155		
130 A	61	195		
171 A	67	236		
200 A	80	291		
255 A	70	344		
312 A	89	457		
365 A	111	507		
412 A	134	571	5 starts / hour 3 x In @ 30 s	40 °C (104 °F)
480 A	209	494		
604 A	314	672		
670 A	380	758		
820 A	329	772		
950 A	431	977		
1100 A	568	1137		
1400 A	901	1710		

**NOTE!**

Table 3.3 shows the maximum power dissipated by the SSW900, considering the maximum permitted duty cycle. So for the cabinets with ventilation designed to meet the dissipated power requirement, the SSW900 will withstand any permitted duty cycle.

**NOTE!**

For the correct dimensioning of the panel ventilation, it is also necessary to consider the heating of all other components installed inside the panel: fuses, circuit breakers, cables, transformers and other components.

**NOTE!**

The air temperature below the SSW900 should not be above 55 °C (131 °F), or 40 °C (104 °F) for models above 412 A when used without current derating.

**NOTE!**

The maximum temperature at the SSW900 power terminals must not exceed 100 °C (212 °F), when at the maximum allowed ambient temperature. So the recommendation is to dimension the cables accordingly to assure temperature levels below 100°C. Preferably use copper cables with PVC insulation 70 °C (158 °F) or copper busbars designed for temperatures up to 80 °C (176 °F), considering the maximum permitted ambient temperature.

3.1.5. Mounting on a Surface

Table 3.3 presents the installation of the SSW900 on the surface of a mounting plate.

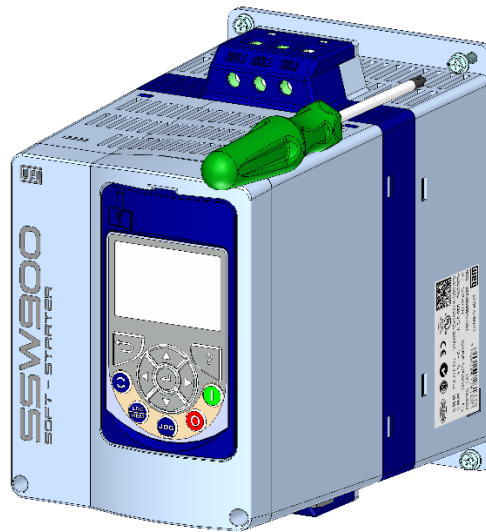

Figure 3.3: Installation procedures of the Soft-Starter SSW900 on a surface

3.2. ELECTRICAL INSTALLATION



ATTENTION!

The following information is a guide for the proper installation. Follow also the applicable local standards for electrical installations.



DANGER!

Assure the AC Power supply is fully isolated before proceeding with terminal handling / connection.



DANGER!

The SSW900 cannot be used as an emergency stop device.



DANGER!

On the first power-up, if a contactor or circuit breaker for power isolation with minimum voltage coil is not used, at the first power on, then power up the electronics first, adjust the trimpots that are necessary to put the SSW900 into operation and only after this energize the power section.

3.2.1. Power Terminals

The power terminal blocks vary in size and configuration, depending on the SSW900 soft-starter model, presented at the Figure 3.4 to Figure 3.7 and Table 3.4.

Connection to the supply line: **R / 1L1, S / 3L2 and T / 5L3**

Motor connection: **U / 2T1, V / 4T2 and W / 6T3**

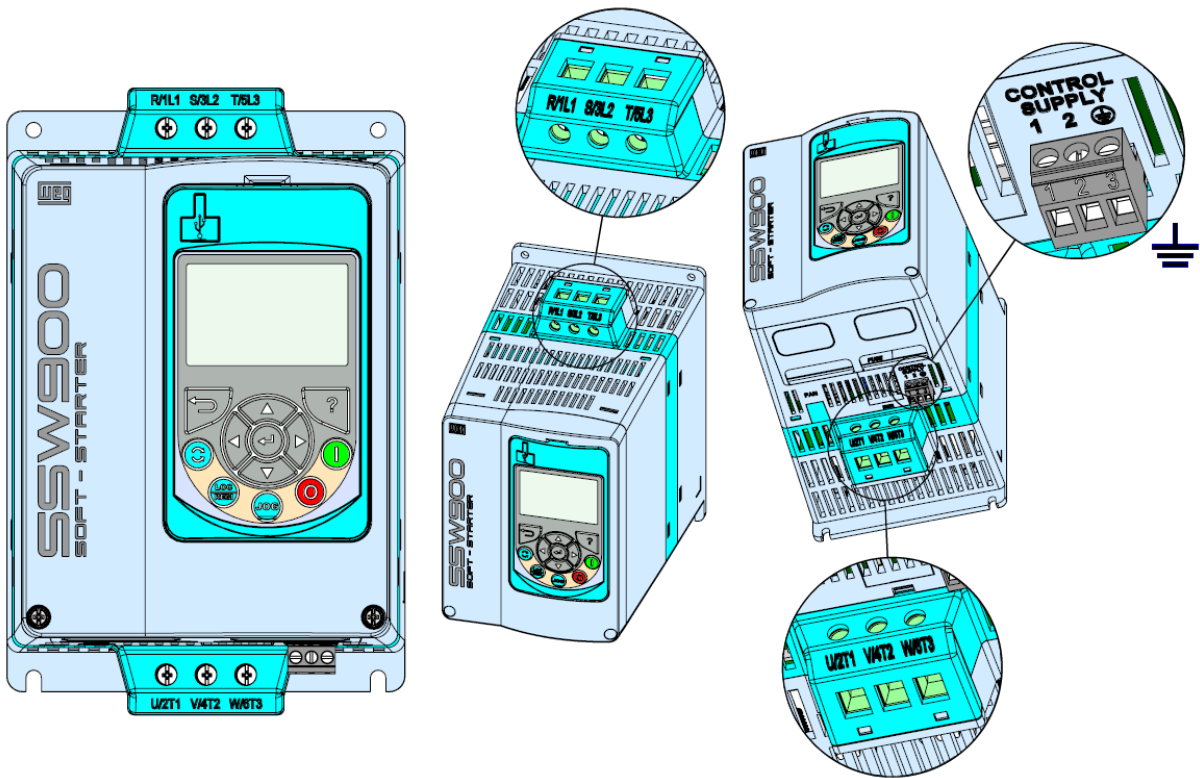

Figure 3.4: Power and grounding terminals, frame A

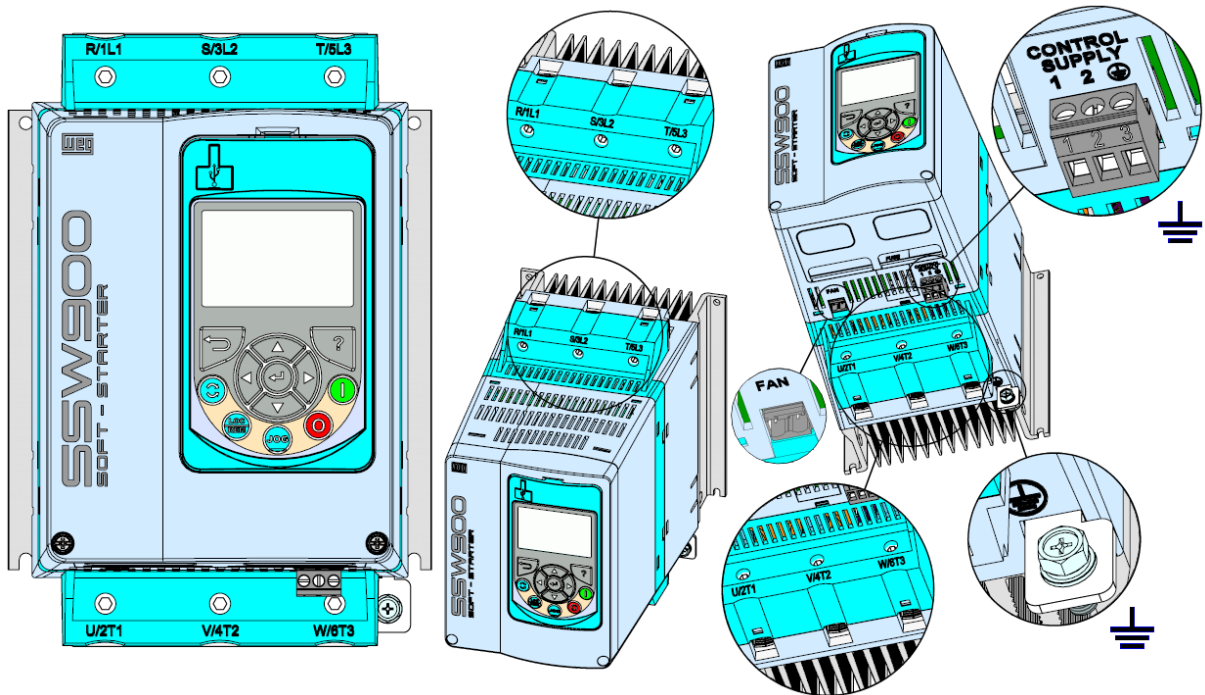

Figure 3.5: Power and grounding terminals, frame B

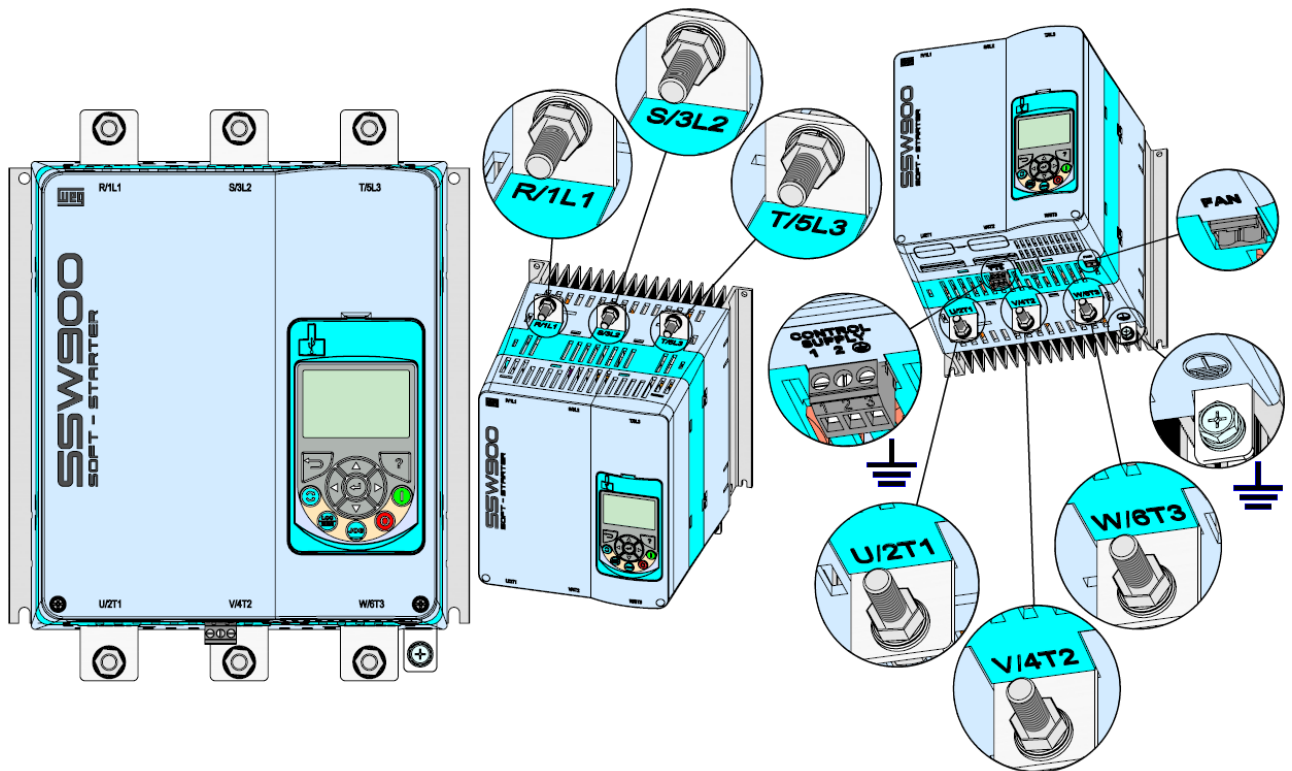

Figure 3.6: Power and grounding terminals, frame C

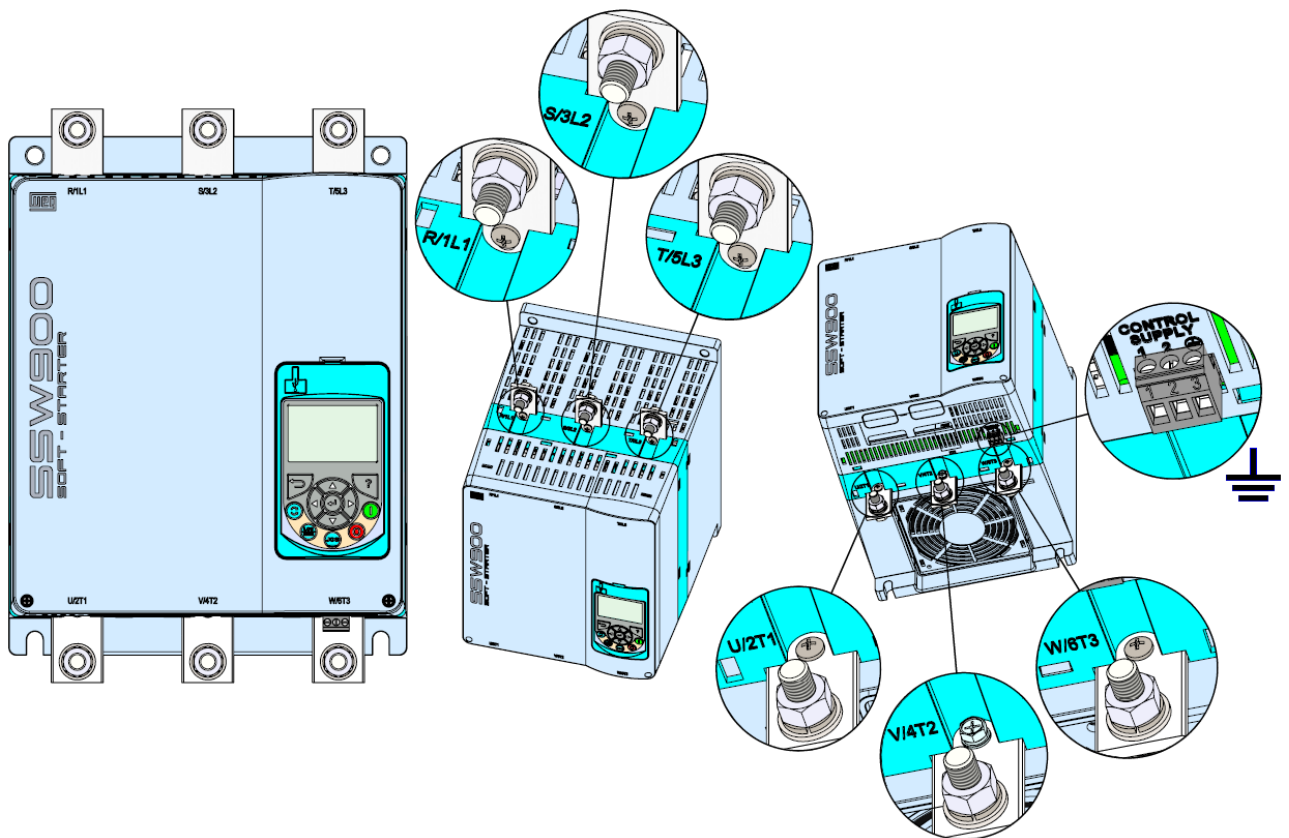

Figure 3.7: Power and grounding terminals, frame D

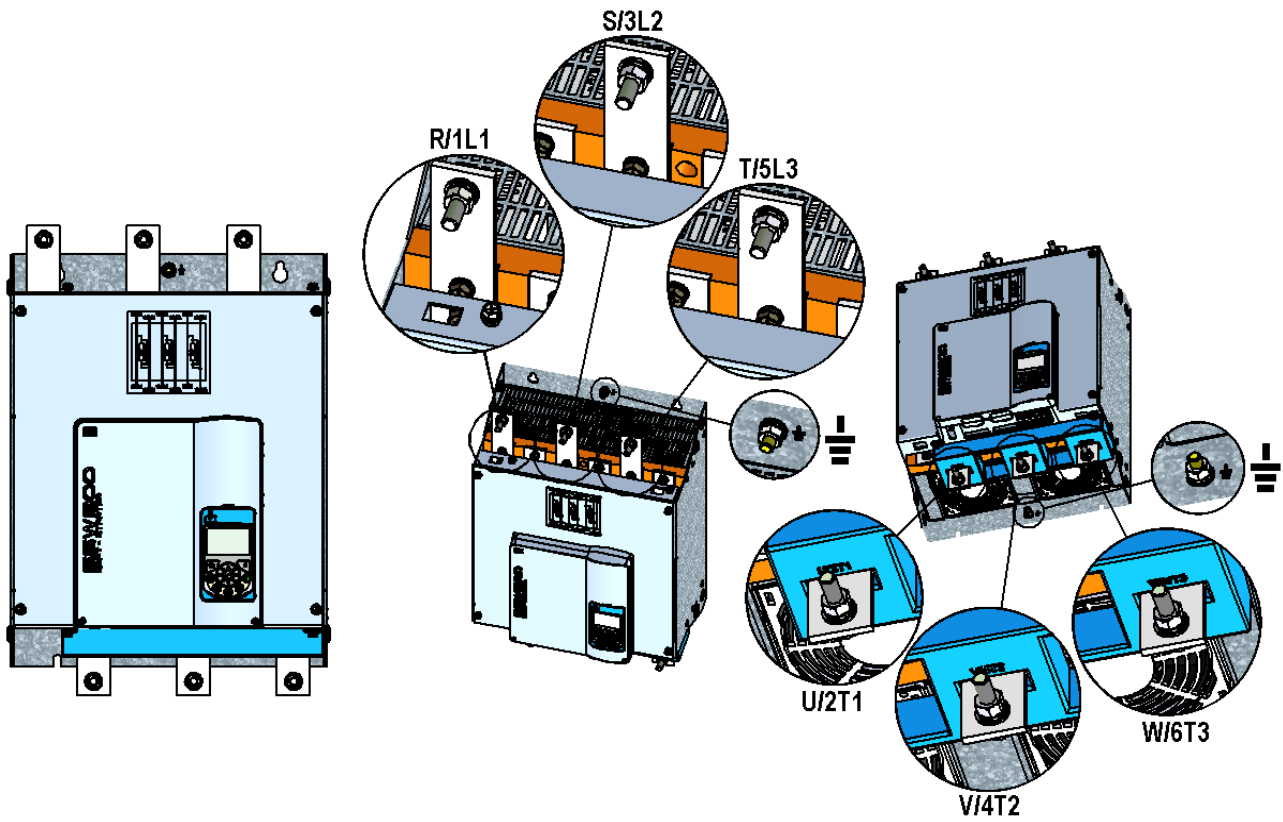

Figure 3.8: Power and grounding terminals, frame E

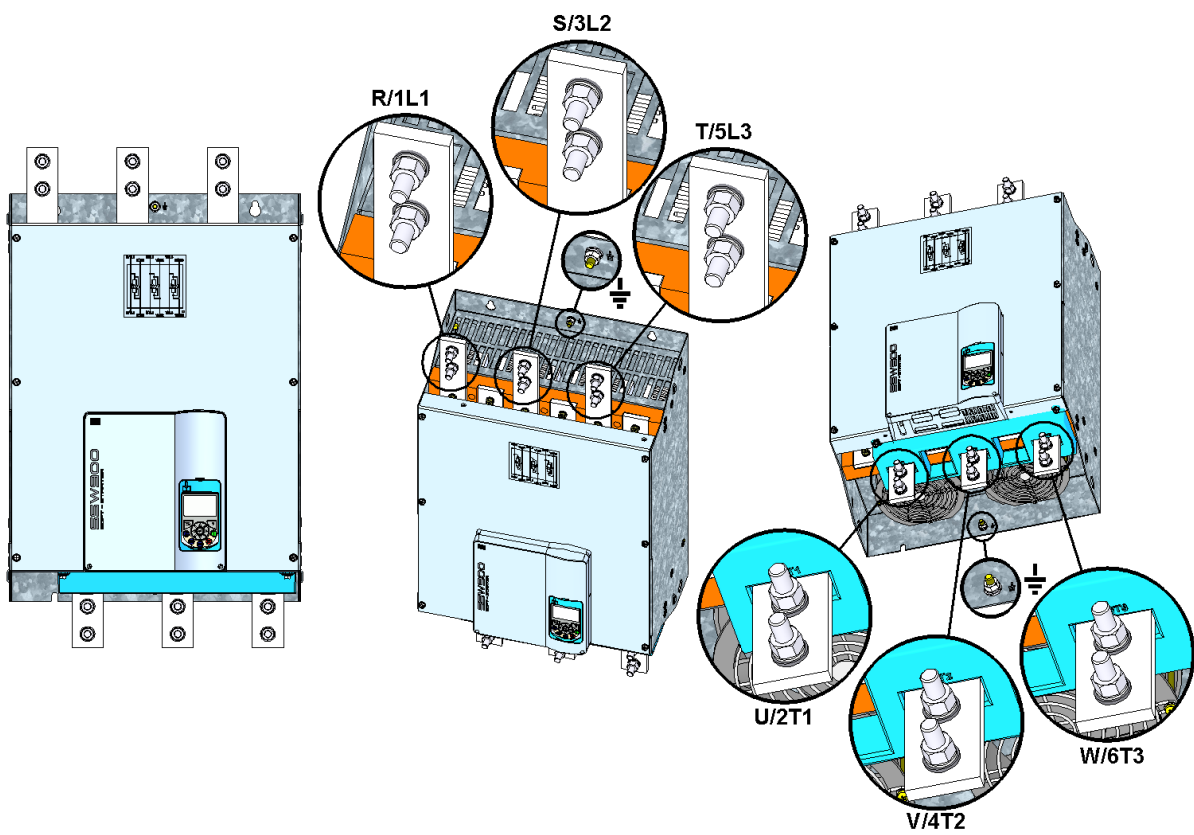

Figure 3.9: Power and grounding terminals, frame F

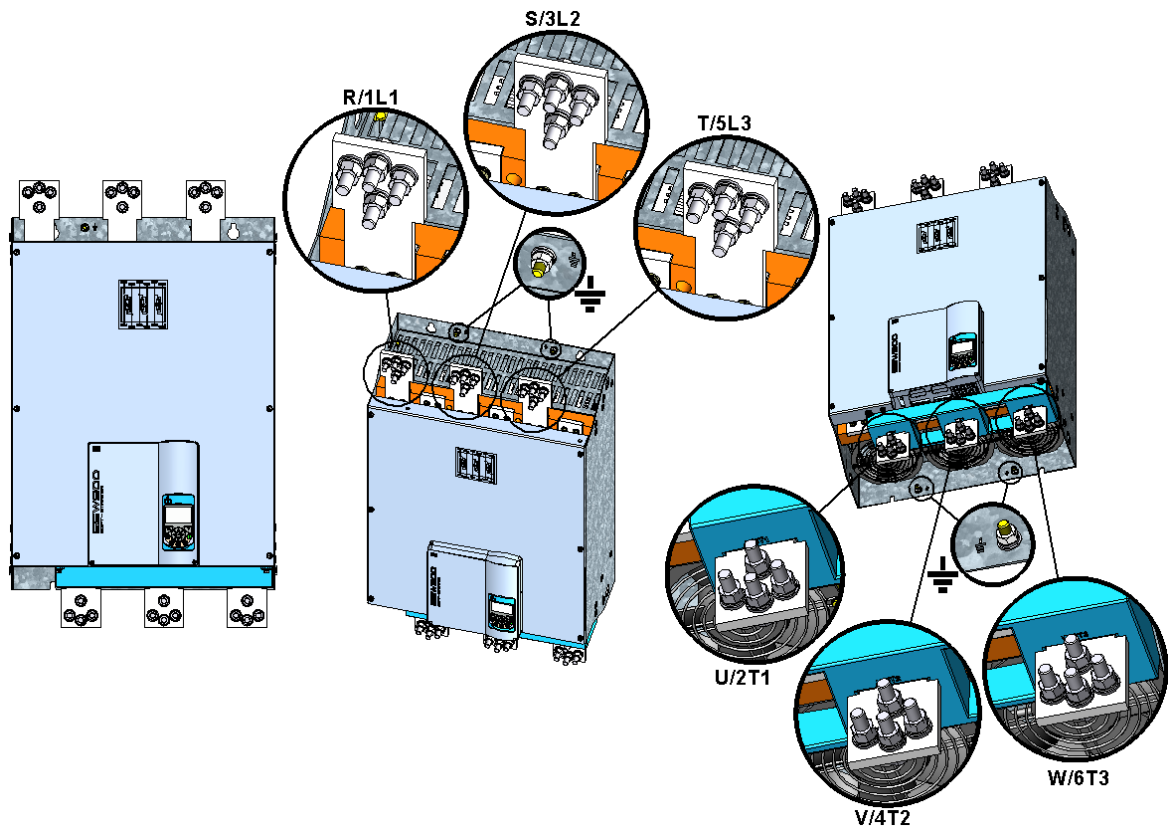

Figure 3.10: Power and grounding terminals, frame G

Table 3.4: Maximum torque for power terminals connection

Model SSW900	Frame	Power Supply Line / Motor		Grounding - Control		Grounding - Power	
		Screw / Terminal	Torque Nm (lbf-in)	Terminal	Torque Nm (lbf-in)	Terminal	Torque Nm (lbf-in)
10 A 17 A 24 A 30 A	A	Terminal	1.5 (27)	Terminal	0.5 (4.5)	-	-
45 A 61 A 85 A 105 A	B	Terminal	5.5 (49)	Terminal	0.5 (4.5)	M5 (3/16")	6 (53)
130 A 171 A 200 A	C	M8 (5/16")	19 (168)	Terminal	0.5 (4.5)	M6 (1/4")	8.3 (73)
255 A 312 A 365 A 412 A	D	M10 (3/8")	37 (328)	Terminal	0.5 (4.5)	-	-
480 A 604 A 670 A	E	M10 (3/8")	37 (328)	Terminal	0.5 (4.5)	M8 (5/16")	15 (132)
820 A 950 A	F	M12 (1/2")	45 (398)	Terminal	0.5 (4.5)	M8 (5/16")	15 (132)
1100 A 1400 A	G	M12 (1/2")	45 (398)	Terminal	0.5 (4.5)	M8 (5/16")	15 (132)

3.2.2.Recommended Power and Grounding Cables - IEC

The described specifications in Table 3.5 and Table 3.6 are valid only for the following conditions:

- Copper wires for 70 °C (158 °F) with PVC insulation, ambient temperature of 40 °C (104 °F), installed in vertical or horizontal perforated channels, with the cables arranged in a single layer.
- Naked or silver coated copper busbars with round edges with 1 mm radius with ambient temperature of 40 °C (104 °F) and bus temperature of 80 °C (176 °F).



NOTE!

For correct cable sizing, consider the installation conditions, the maximum permitted line voltage drop accepted, and follow the electrical instructions defined by local regulations.

Table 3.5: Recommended cables and busbar for standard connection - IEC

Model SSW900	Current 100 % In A	C2 Cables mm ²	C2 Busbar mm x mm	Ground Cables	
				Power mm ²	Control mm ²
10 A	10	2.5	-	-	2.5
17 A	17	2.5	-	-	2.5
24 A	24	4	-	-	2.5
30 A	30	6	-	-	2.5
45 A	45	10	-	6	2.5
61 A	61	16	-	10	2.5
85 A	85	25	-	10	2.5
105 A	105	35	-	25	2.5
130 A	130	50	20 x 3	25	2.5
171 A	171	70	20 x 3	35	2.5
200 A	200	95	20 x 3	50	2.5
255 A	255	120	25 x 5	-	2.5
312 A	312	150	25 x 5	-	2.5
365 A	365	185	25 x 5	-	2.5
412 A	412	240	30 x 5	-	2.5
480 A	480	300	40 x 5	120	2.5
604 A	604	2 x 120	40 x 10	150	2.5
670 A	670	2 x 150	40 x 10	150	2.5
820 A	820	2 x 240	40 x 10	240	2.5
950 A	950	2 x 300	50 x 10	300	2.5
1100 A	1100	3 x 240	60 x 10	2 x 120	2.5
1400 A	1400	3 x 300	80 x 10	2 x 150	2.5

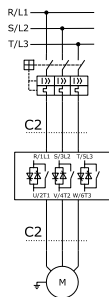
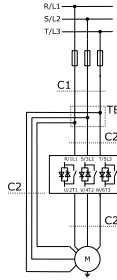

Table 3.6: Recommended cables and busbar for delta inside motor connection - IEC

Model SSW900	Current 100 % In A	C1 Line Cables mm ²	C1 Line Busbar mm x mm	C2 Motor Cables mm ²	C2 Motor Busbar mm x mm	Ground Cables	
						Power mm ²	Control mm ²
130 A	225	95	20 x 3	50	20 x 3	25	2.5
171 A	296	150	25 x 5	70	20 x 3	35	2.5
200 A	346	185	25 x 5	95	20 x 3	50	2.5
255 A	441	300	30 x 5	120	25 x 5	-	2.5
312 A	540	2 x 120	40 x 5	185	25 x 5	-	2.5
365 A	631	2 x 150	40 x 10	240	25 x 5	-	2.5
412 A	713	2 x 185	40 x 10	240	30 x 5	-	2.5
480 A	831	2 x 240	40 x 10	300	40 x 5	120	2.5
604 A	1046	2 x 300	60 x 10	2 x 120	40 x 10	150	2.5
670 A	1160	3 x 240	60 x 10	2 x 150	40 x 10	150	2.5
820 A	1420	3 x 300	80 x 10	2 x 240	40 x 10	240	2.5
950 A	1645	4 x 240	100 x 10	2 x 300	50 x 10	300	2.5
1100 A	1905	4 x 300	120 x 10	3 x 240	60 x 10	2 x 120	2.5
1400 A	2425	6 x 300	160 x 10	3 x 300	80 x 10	2 x 150	2.5

NOTE!

Do not shunt power cables on the SSW900 terminals. Use “TB - terminal blocks” to shunt the power cables as per the connection drawing.

NOTE!

For the connection of the external bypass contactor, use the same cable or busbar model used in the motor connection.

3.2.3.Recommended Power and Grounding Cables - UL

The described specifications in Table 3.7 and Table 3.8 are based on:

- UL 508 – Table 45.3 – Ampacities of insulated conductors, with cooper cables, 75 °C (167 °F).
- UL 508 – Table 45.4 – Width of cooper bus bars.
- UL 508 – Table 42.1 – Size of equipment grounding conductor, with cooper cables.

NOTE!

For correct cable sizing, consider the installation conditions, the maximum permitted line voltage drop accepted, and follow the electrical instructions defined by local regulations.

Table 3.7: Recommended cables and busbar for standard connection - UL

Model SSW900	Current 100 % In A	C2 Cables AWG	C2 Busbar in x in	Grounding Cables	
				Power AWG	Control AWG
10 A	10	14	-	-	14
17 A	17	12	-	-	14
24 A	24	10	-	-	14
30 A	30	10	-	-	14
45 A	45	8	-	10	14
61 A	61	6	-	8	14
85 A	85	4	-	8	14
105 A	105	2	-	6	14
130 A	130	1/0	3/4 x 1/16	6	14
171 A	171	2/0	3/4 x 1/8	6	14
200 A	200	3/0	3/4 x 1/8	6	14
255 A	255	250 kcmil	3/4 x 1/4	-	14
312 A	312	350 kcmil	3/4 x 1/4	-	14
365 A	365	500 kcmil	1 x 1/4	-	14
412 A	412	600 kcmil	1 x 1/4	-	14
480 A	480	2 x 250 kcmil	1 x 1/2	2	14
604 A	604	2 x 350 kcmil	1 1/4 x 1/2	0	14
670 A	670	2 x 400 kcmil	1 1/2 x 1/2	0	14
820 A	820	2 x 600 kcmil	1 1/2 x 1/2	2/0	14
950 A	950	2 x 750 kcmil	1 3/4 x 1/2	2/0	14
1100 A	1100	3 x 500 kcmil	2 x 1/2	3/0	14
1400 A	1400	3 x 750 kcmil	3 x 1/2	4/0	14

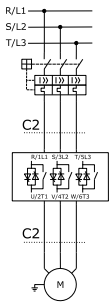
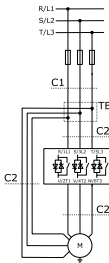

Table 3.8: Recommended cables and busbar for delta inside motor connection – UL

Model SSW900	Current 100 % In A	C1 Line Cables AWG	C1 Line Busbar in x in	C2 Motor Cables AWG	C2 Motor Busbar in x in	Grounding Cables	
						Power AWG	Control AWG
130 A	225	250 kcmil	3/4 x 1/8	1/0	3/4 x 1/16	6	14
171 A	296	350 kcmil	3/4 x 1/4	2/0	3/4 x 1/8	6	14
200 A	346	500 kcmil	1 x 1/4	3/0	3/4 x 1/8	6	14
255 A	441	700 kcmil	1 x 1/4	250 kcmil	3/4 x 1/4	-	14
312 A	540	2 x 300 kcmil	1 x 1/2	350 kcmil	3/4 x 1/4	-	14
365 A	631	2 x 400 kcmil	1 1/4 x 1/2	500 kcmil	1 x 1/4	-	14
412 A	713	2 x 500 kcmil	1 1/4 x 1/2	600 kcmil	1 x 1/4	-	14



NOTE!

Do not shunt power cables on the SSW900 terminals. Use “TB - terminal blocks” to shunt the power cables as per the connection drawing.



NOTE!

For the connection of the external bypass contactor, use the same cable or busbar used in the motor connection.

3.2.4.SSW900 - Power supply connection



DANGER!

The power supply voltage level should be within the SSW900 rated voltage range.



DANGER!

Provide a power supply disconnecting switch for the SSW900. This disconnecting switch must disconnect the AC input voltage to the SSW900 whenever necessary (for example: during maintenance services).

When a disconnected switch or a contactor is inserted in the motor supply line never operate these devices with the motor running or when the SSW900 is enabled.



ATTENTION!

The power supply voltage level should be protected against overvoltage with suppressors clamping voltage levels over 680Vac (phase to phase) and with the energy absorption capacity of 40 joules on models from 10A to 200A and 80 joules on models from 255A up to 670A.



NOTE!

See recommended cables on Item 3.2.2.
See tightening torque on Item 3.2.1.

3.2.5.Short Circuit Capacity – Tested at UL

Table 3.9 presents the short circuit capacity of the power supply (symmetric Arms), Standard Fault, at which the SSW900 can be installed within an enclosed cabinet, provided that protected by means of general purpose fuses or circuit breakers, used in the UL tests.

Table 3.9: Short circuit capacity – Standard Fault up to 600V - UL

Model SSW900	Optional LUG	Standard Fault up to 600 V kA	Q1 Circ. Breaker Any MCCB – UL489 A	F1 Fuse Time-Delay A	Minimal Cabinet Dimensions % of Product Size
10 A	-	5	≤ 30 (1)	RK5 50 (3)	150%
17 A	-	5	≤ 40 (1)	RK5 50 (3)	150%
24 A	-	5	≤ 40 (1)	RK5 50 (3)	150%
30 A	-	5	≤ 40 (1)	RK5 50 (3)	150%
45 A	-	5	≤ 150 (1)	RK5 125 (3)	150%
61 A	-	5	≤ 200 (1)	RK5 125 (3)	150%
85 A	-	5	≤ 225 (1)	RK5 125 (3)	150%
105 A	-	10	≤ 225 (1)	RK5 250 (3)	150%
130 A	ATTA-350-38	10	≤ 350 (1) (2)	RK5 350 (3) (4)	150%
171 A	ATTA-350-38	10	≤ 400 (1) (2)	RK5 350 (3) (4)	150%
200 A	ATTA-350-38	18	≤ 400 (1) (2)	RK5 600 (3) (4)	150%
255 A	ATAU-350-12	30	≤ 600 (1) (2)	Class L 500 (3) (4)	150%
312 A	ATAU-350-12	30	≤ 600 (1) (2)	Class L 700 (3) (4)	150%
365 A	ATAU-350-12	42	≤ 600 (1) (2)	Class L 700 (3) (4)	150%
412 A	ATAU-350-12	42	≤ 600 (1) (2)	Class L 1000 (3) (4)	150%
480 A	ATAU-600-12	42	≤ 1200 (1)	-	150%
604 A	ATAU-600-12	42	≤ 1200 (1)	-	150%
670 A	ATAU-600-12	42	≤ 1200 (1)	-	150%
820 A	PB4-600-2N	85 (up to 480 V)	≤ 1600 (1)	Class L 2000 (3)	150%
950 A	PB4-600-2N	85 (up to 480 V)	≤ 1600 (1)	Class L 2000 (3)	150%
1100 A	PBMW-4-750-12	85 (up to 480 V)	≤ 2500 (1)	Class L 2500 (3)	150%
1400 A	PBMW-4-750-12	85 (up to 480 V)	≤ 2500 (1)	Class L 2500 (3)	150%

(1) (2) (3) (4) Motor connection diagram:

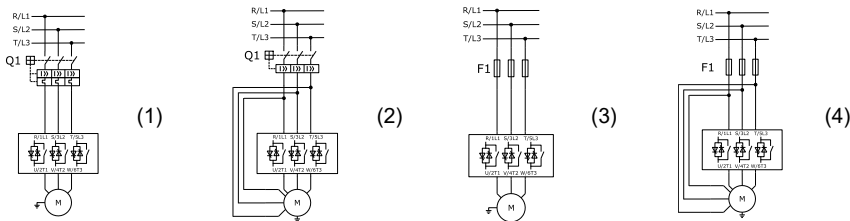

Table 3.10 and Table 3.11 presents the short circuit capacity of the power supply (symmetric Arms), High Fault, at which the SSW900 can be installed within an enclosed cabinet, motor with standard connection, provided that protected by means circuit breakers, used in the UL tests.

Table 3.10: Short circuit capacity – High Fault 480V - UL

Model SSW900	Optional LUG	High Fault 480 V kA	Q1 Circ. Breaker MCCB – UL489	Minimal Cabinet Dimensions		
				Width mm (in)	Height mm (in)	Depth mm (in)
10 A	-	65	WEG UBW225H 600V, 30A Or EATON HFD3030L (1)	300 (11.81)	190.5 (7.50)	304.5 (11.99)
17 A	-	65	WEG UBW225H 600V, 40A Or EATON HFD3040L (1)	300 (11.81)	190.5 (7.50)	304.5 (11.99)
24 A	-	65	WEG UBW225H 600V, 40A Or EATON HFD3040L (1)	300 (11.81)	190.5 (7.50)	304.5 (11.99)
30 A	-	65	WEG UBW225H 600V, 40A Or EATON HFD3040L (1)	300 (11.81)	190.5 (7.50)	304.5 (11.99)
45 A	-	65	WEG UBW225H 600V, 150A Or EATON HFD3150L (1)	462 (18.19)	216 (8.50)	390.1 (15.36)
61 A	-	65	WEG UBW225H 600V, 200A Or EATON HFD3200L (1)	462 (18.19)	216 (8.50)	390.1 (15.36)
85 A	-	65	WEG UBW225H 600V, 225A Or EATON HFD3225L (1)	462 (18.19)	216 (8.50)	390.1 (15.36)
105 A	-	65	WEG UBW225H 600V, 225A Or EATON HFD3225L (1)	462 (18.19)	216 (8.50)	390.1 (15.36)
130 A	ATTA-350-38	65	WEG UBW400H, 600V, 350A or EATON HKD3350 or WEG UBW225H 600V, 225A or UBW250H 600V, 250A (1) (2)	784.1 (30.87)	334.5 (13.17)	391.7 (15.42)
171 A	ATTA-350-38	65	WEG UBW400H, 600V, 400A or EATON HKD3400 or UBW250H 600V, 250A or WEG UBW225H 600V, 225A (1) (2)	784.1 (30.87)	334.5 (13.17)	391.7 (15.42)
200 A	ATTA-350-38	65	WEG UBW400H, 600V, 400A Or EATON HKD3400 or UBW250H 600V, 250A (1) (2)	784.1 (30.87)	334.5 (13.17)	391.7 (15.42)
255 A	ATAU-350-12	65	WEG UBW600H, 600V, 600A, or EATON HLD3600 (1) (2) or WEG UBW400H, 600V, 400A	839 (33.03)	340.6 (13.41)	422.9 (16.55)
312 A	ATAU-350-12	65	WEG UBW600H, 600V, 600A, or EATON HLD3600 (1) (2) or WEG UBW400H, 600V, 400A	839 (33.03)	340.6 (13.41)	422.9 (16.55)
365 A	ATAU-350-12	65	WEG UBW600H, 600V, 600A or 500A, or EATON HLD3600 (1) (2) or WEG UBW400H, 600V, 400A	839 (33.03)	340.6 (13.41)	422.9 (16.55)
412 A	ATAU-350-12	65	WEG UBW600H, 600V, 600A or 500A, or EATON HLD3600 (1) (2) or WEG UBW400H, 600V, 400A	839 (33.03)	340.6 (13.41)	422.9 (16.55)
480 A	ATAU-600-12	65	WEG UBW1200H, 600V, 1200A or EATON NGH312033E (1) or WEG UBW600H, 600V, 600A or WEG UBW800H, 600V, 800A	1032 (40.63)	584.9 (23.03)	390.1 (15.36)
604 A	ATAU-600-12	65	WEG UBW1200H, 600V, 1200A or EATON NGH312033E (1) or WEG UBW800H, 600V, 800A	1032 (40.63)	584.9 (23.03)	390.1 (15.36)
670 A	ATAU-600-12	65	WEG UBW1200H, 600V, 1200A or EATON NGH312033E (1) or WEG UBW800H, 600V, 800A	1032 (40.63)	584.9 (23.03)	390.1 (15.36)

(1) (2) Motor connection diagram:

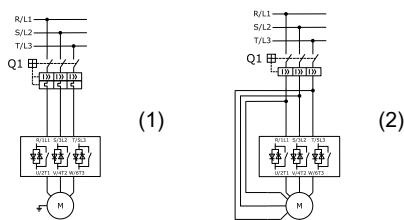
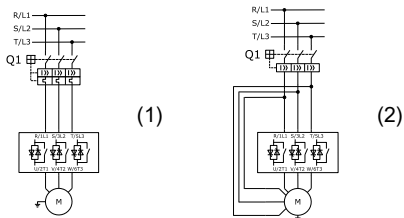

Table 3.11: Short circuit capacity – High Fault 600V - UL

Model SSW900	Optional LUG	High Fault 600 V kA	Q1 Circ. Breaker MCCB – UL489	Minimal Cabinet Dimensions		
				Width mm (in)	Height mm (in)	Depth mm (in)
10 A	-	18	WEG UBW225H 600 V, 30 A Or EATON HFD3030L (1)	300 (11.81)	190.5 (7.50)	304.5 (11.99)
17 A	-	18	WEG UBW225H 600 V, 40 A Or EATON HFD3040L (1)	300 (11.81)	190.5 (7.50)	304.5 (11.99)
24 A	-	18	WEG UBW225H 600 V, 40 A Or EATON HFD3040L (1)	300 (11.81)	190.5 (7.50)	304.5 (11.99)
30 A	-	18	WEG UBW225H 600 V, 40 A Or EATON HFD3040L (1)	300 (11.81)	190.5 (7.50)	304.5 (11.99)
45 A	-	18	WEG UBW225H 600 V, 150 A Or EATON HFD3150L (1)	462 (18.19)	216 (8.50)	390.1 (15.36)
61 A	-	18	"WEG UBW225H 600 V, 200 A Or EATON HFD3200L" (1)	462 (18.19)	216 (8.50)	390.1 (15.36)
85 A	-	18	"WEG UBW225H 600 V, 225 A Or EATON HFD3225L" (1)	462 (18.19)	216 (8.50)	390.1 (15.36)
105 A	-	18	WEG UBW225H 600 V, 225 A Or EATON HFD3225L (1)	462 (18.19)	216 (8.50)	390.1 (15.36)
130 A	ATTA-350-38	30	WEG UBW400H, 600 V, 350 A Or EATON HKD3350 (1) (2)	784.1 (30.87)	334.5 (13.17)	391.7 (15.42)
171 A	ATTA-350-38	30	WEG UBW400H, 600 V, 400 A Or EATON HKD3400 (1) (2)	784.1 (30.87)	334.5 (13.17)	391.7 (15.42)
200 A	ATTA-350-38	30	WEG UBW400H, 600 V, 400 A Or EATON HKD3400 (1) (2)	784.1 (30.87)	334.5 (13.17)	391.7 (15.42)
255 A	ATAU-350-12	42	WEG UBW600L, 600 V, 600 A or EATON LDC3600 (1) (2)	839 (33.03)	340.6 (13.41)	422.9 (16.55)
312 A	ATAU-350-12	42	WEG UBW600L, 600 V, 600 A or EATON LDC3600 (1) (2)	839 (33.03)	340.6 (13.41)	422.9 (16.55)
365 A	ATAU-350-12	42	WEG UBW600L, 600 V, 600 A or EATON LDC3600 (1) (2)	839 (33.03)	340.6 (13.41)	422.9 (16.55)
412 A	ATAU-350-12	42	WEG UBW600L, 600 V, 600 A or EATON LDC3600 (1) (2)	839 (33.03)	340.6 (13.41)	422.9 (16.55)

(1) (2) Motor connection diagram:



3.2.6. Input Circuit Breakers and Fuses- IEC

Ultra-fast fuses class aR, regular fuses or circuit breakers:

For Coordination Type 1, general purpose fuses (class gG), conductor protection fuses (class gL) can be used, according to IEC 60947-4-2, which will protect the installation against short circuits; however, the SCRs will not be protected. Table 3.9 and Table 3.10.

For Coordination Type 2, the fuses to be used in the input must be for protection of semiconductors, ultra-fast class aR, according to IEC 60269-4. These fuses mitigate the risk of SCR damage due to transient overcurrent.

The recommended WEG ultra-fast (class aR) fuses on Table 3.11, Table 3.12 and Table 3.14 are considering the maximum power supply voltage level for each model of the SSW900. It was also considered starts with current limit control with 300% of the rated SSW900 current, during 30 seconds. The number of starts considered were 10 or 5 starts per hour according to each SSW900 model. For applications other than these conditions, review the design of the fuses.

Table 3.12: Recommended Weg aR fuses per phase for standard connection

Model SSW900	I ² t of the SCR (A ² s)	F1 FNH aR Blade Contacts	F1 FNHFE aR Flush End
10 A	720	1 x FNH000-35K-A / FNH00-40K-A (1)	-
17 A	720	1 x FNH000-40K-A / FNH00-40K-A (1)	-
24 A	4000	1 x FNH000-80K-A / FNH00-80K-A (1)	-
30 A	4000	1 x FNH000-100K-A / FNH00-100K-A (1)	-
45 A	8000	1 x FNH000-125K-A / FNH00-125K-A (1)	-
61 A	10500	1 x FNH00-160K-A (1)	-
85 A	51200	1 x FNH00-250K-A (1)	1 x FNH3FEM-450Y-A (1)
105 A	125000	1 x FNH1-315K-A (1)	1 x FNH3FEM-450Y-A (1)
130 A	97000	1 x FNH1-400K-A (1)	1 x FNH3FEM-450Y-A (1)
171 A	168000	1 x FNH2-500K-A (1)	1 x FNH3FEM-450Y-A (1)
200 A	245000	1 x FNH2-630K-A (1)	1 x FNH3FEM-450Y-A (1)
255 A	90000	2 x FNH3-710K-A (4)	1 x FNH3FEM-500Y-A (1)
312 A	238000	1 x FNH3-800K-A (1)	1 x FNH3FEM-700Y-A (1)
365 A	238000	2 x FNH3-900K-A (4)	1 x FNH3FEM-700Y-A (1)
412 A	320000	2 x FNH3-1000K-A (4)	1 x FNH3FEM-800Y-A (1)
480 A	320000	-	1 x FNH23FEA-1000Y-A (1)
604 A	781000	-	1 x FNH23FEA-1250Y-A (1)
670 A	1125000	-	1 x FNH23FEA-1400Y-A (1)
820 A	1200000	-	1 x FNH23FEA-1600Y-A (1)
950 A	2530000	-	1 x FNH23FEA-1800Y-A (1)
1100 A	3630000	-	1 x FNH23FEA-2000Y-A (1)
1400 A	10100000	-	2 x FNH3FEM-1250Y-A (2)

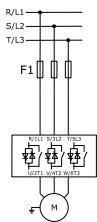

(1) (2) (4) Fuses connection diagram:

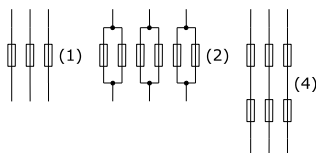
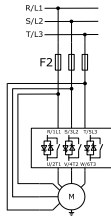

Table 3.13: Recommended Weg aR fuses delta inside connection with the fuses outside of the delta

Model SSW900	I ² t of the SCR (A ² s)	F2 FNH aR Blade Contacts	F2 FNHFE aR Flush End
130 A	97000	1 x FNH2-630K-A (1)	1 x FNH3FEM-450Y-A (1)
171 A	168000	1 x FNH3-800K-A (1)	1 x FNH3FEM-630Y-A (1)
200 A	245000	1 x FNH3-1000K-A (1)	1 x FNH3FEM-700Y-A (1)
255 A	90000	-	2 x FNH3FEM-900Y-A (4)
312 A	238000	-	1 x FNH3FEM-1000Y-A (1)
365 A	238000	-	1 x FNH23FEA-1250Y-A (1)
412 A	320000	-	1 x FNH23FEA-1400Y-A (1)
480 A	320000	-	1 x FNH23FEA-1400Y-A (1)
604 A	781000	-	1 x FNH23FEA-2000Y-A (1)
670 A	1125000	-	1 x FNH23FEA-2000Y-A (1)
820 A	1200000	-	4 x FNH23FEA-1400Y-A (5)
950 A	2530000	-	3 x FNH3FEM-1000Y-A (3)
1100 A	3630000	-	3 x FNH3FEM-1100Y-A (3)
1400 A	10100000	-	3 x FNH3FEM-1400Y-A (3)



(1) (3) (4) (5) Fuses connection diagram:

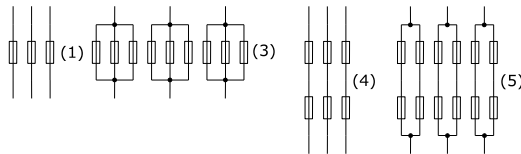
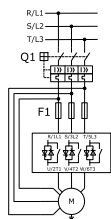
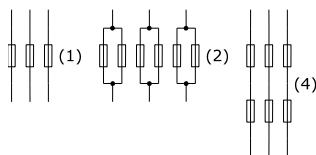

Table 3.14: Recommended Weg aR fuses delta inside connection with the fuses inside of the delta

Modelo SSW900	I ² t do SCR A ² s	F1 FNH aR Blade Contacts	F1 FNHFE aR Flush End
130 A	97000	1 x FNH2-400K-A (1)	1 x FNH3FEM-450Y-A (1)
171 A	168000	1 x FNH2-500K-A (1)	1 x FNH3FEM-450Y-A (1)
200 A	245000	1 x FNH3-630K-A (1)	1 x FNH3FEM-450Y-A (1)
255 A	90000	2 x FNH3-630K-A (4)	2 x FNH3FEM-500Y-A (4)
312 A	238000	2 x FNH3-800K-A (4)	1 x FNH3FEM-630Y-A (1)
365 A	238000	2 x FNH3-800K-A (4)	1 x FNH3FEM-630Y-A (1)
412 A	320000	2 x FNH3-900K-A (4)	1 x FNH3FEM-700Y-A (1)
480 A	320000	-	2 x FNH3FEM-900Y-A (4)
604 A	781000	-	2 x FNH3FEM-1100Y-A (4)
670 A	1125000	-	1 x FNH23FEA-1250Y-A (1)
820 A	1200000	-	1 x FNH23FEA-1400Y-A (1)
950 A	2530000	-	1 x FNH23FEA-1800Y-A (1)
1100 A	3630000	-	1 x FNH23FEA-2000Y-A (1)
1400 A	10100000	-	2 x FNH3FEM-1250Y-A (2)



(1) (2) (4) Fuses connection diagram:



NOTE!

For some of the SSW900 models, it is recommended fuses in series, and that's to meet the type 2 coordination in conjunction to the I^2t level which needs to be lesser than the starter SCR. When the requirement is for parallel connection, that's to meet the SSW900 starting current level.

NOTE!

The maximum I^2t of the fuse of the SSWs varies according to the design of the SCR used; therefore, higher rated currents may present lower I^2t .

NOTE!

Starting controls which doesn't limit the motor start current and short starting times can blow fuses prematurely.
Preferably use starting times that keep the current below 300% of the SSW current.

The fuse rated current should preferably be equal to or higher than the motor starting current in order to prevent cyclic overloads and the tripping of the fuse in the prohibited area of the Time x Current curve.

The proper sizing of the fuse should take into account: the local standards for electrical installations, the starting cycle, number of starts per hour, starting current and starting time, ambient temperature and altitude.

For the correct sizing of the fuses, see WEG Fuse Catalog:

www.weg.net

Automation - Fuses aR and gL/gG - Type NH Blade Contact, NH Flush End and Diametral.

Annex 1: Sizing Criteria for Ultra-Fast Fuses aR Blade Contact and Flush End.

Annex 2: Table for aR Fuse Sizing to Protect SSW900 Soft-Starters and CFW Inverters.

Table 3.15: Coordination types for standard connection

<p>Type 1</p>	<p>Type 2</p>	<p>Q1 – short circuit protection circuit breaker and when it is necessary to disconnect the SSW from the power supply. This circuit breaker with shunt trip coil can be disabled via a digital output of the SSW.</p> <p>F2 – high speed semiconductor protection fuse.</p>
<p>Type 1</p>	<p>Type 2</p>	<p>S1 – fuse-switch-disconnector – when it is necessary to disconnect the SSW from the power supply.</p> <p>F1 – general purpose short circuit protection fuse.</p> <p>F2 – ultra fast semiconductor protection fuse.</p> <p>F3 – double protection fuse, that is, short circuit and ultra-fast semiconductor protection.</p>
<p>Type 1</p>	<p>Type 2</p>	<p>K1 – isolation contactor – used when it is necessary to disconnect the SSW from the power supply with the motor turned off. It can be controlled by a digital output of the SSW.</p> <p>F1 – general purpose short circuit protection fuse.</p> <p>F2 – ultra fast semiconductor protection fuse.</p> <p>F3 – double protection fuse, that is, short circuit and ultra-fast semiconductor protection.</p>
<p>Type 1</p>	<p>Type 2</p>	<p>S1 – switch-disconnector – when it is necessary to disconnect the SSW from the power supply.</p> <p>F1 – general purpose short circuit protection fuse.</p> <p>F2 – ultra fast semiconductor protection fuse.</p> <p>F3 – double protection fuse, that is, short circuit and ultra-fast semiconductor protection.</p>

Table 3.16: Coordination types for delta inside connection

<p>Type 1</p> <p>Type 2</p>	<p>Q1 – short circuit protection circuit breaker and when it is necessary to disconnect the SSW from the power supply. This circuit breaker with shunt trip coil can be disabled via a digital output of the SSW.</p> <p>F2 – ultra fast semiconductor protection fuse. Delta inside current only.</p>
<p>Type 1</p> <p>Type 2</p> <p>Type 2</p>	<p>S1 – fuse-switch-disconnector – when it is necessary to disconnect the SSW from the power supply.</p> <p>F1 – general purpose short circuit protection fuse. Total motor current.</p> <p>F2 – ultra fast semiconductor protection fuse. Delta inside current only.</p> <p>F3 – double protection fuse, that is, short circuit and ultra-fast semiconductor protection. Total motor current.</p>
<p>Type 1</p> <p>Type 2</p> <p>Type 2</p>	<p>K1 – isolation contactor – used when it is necessary to disconnect the SSW from the power supply with the motor turned off. It can be controlled by a digital output of the SSW.</p> <p>F1 – general purpose short circuit protection fuse. Total motor current.</p> <p>F2 – ultra-fast semiconductor protection fuse. Delta inside current only.</p> <p>F3 – double protection fuse, that is, short circuit and ultra-fast semiconductor protection. Total motor current.</p>
<p>Type 1</p> <p>Type 2</p> <p>Type 2</p>	<p>S1 – switch-disconnector – when it is necessary to disconnect the SSW from the power supply.</p> <p>F1 – general purpose short circuit protection fuse. Total motor current.</p> <p>F2 – ultra-fast semiconductor protection fuse. Delta inside current only.</p> <p>F3 – double protection fuse, that is, short circuit and ultra-fast semiconductor protection. Total motor current.</p>

3.2.7. Main Input Contactor or Circuit Breaker

In the unlikely case of damages in the power circuit of the SSW900 and the SSW900 fails closed, keeping the motor connected to the main power supply, the motor protection is only obtained by using the power isolation contactor (K1) or circuit breaker (Q1) with shunt trip coil, according to Section 3.4.

An AC3 contactor with rated current higher than or equal to the rated current of the motor connected to the SSW900 must be used.

In order to select the correct sizing of the contactor, see WEG Contactor Catalog:

www.weg.net

Controls - Motor Start and Protection

3.2.8. Bypass Contactor

The SSW900 has internal bypass contactor; however, it is recommended the use of an external bypass contactor for applications where the motor may frequently present locked rotor during the full operating duty. In this case, an AC3 contactor with rated current higher than or equal to the rated current of the motor connected to the SSW900 must be used.

Example of loads:

Crushers, grinders, chippers, conveyor belts.

When the external bypass contactor is used, it is necessary to install the current transformers in the motor power supply output, so as to keep the current indications and protections.

For sizes A to D, use the current measurement accessory (see Chapter 6). For mechanics E to G, reposition the current transformer of the SSW900.

In order to select the correct sizing of the contactor, see WEG Contactor Catalog:

www.weg.net

Controls - Motor Start and Protection

3.2.9. Connection of the SSW900 to the motor



DANGER!

Never connect power factor correction capacitors on the output of the SSW900 (U/2T1, V/4T2 and W/6T3).



ATTENTION!

The motor rated current should not be less than 30% of the SSW900 rated current for the correct operation of the motor readings and protections.

We do not recommend the use of motors that run under duty with a load below 50 % of its rated current.



ATTENTION!

If the Motor Service Factor is being used in your application, consider it when sizing the maximum current of the SSW900.



NOTE!

See recommended cables in Item 3.2.2.

See tightening torque in Item 3.2.1.

NOTE!

The SSW900 has an electronic motor overload protection, which must be adjusted according to the specific motor. When several motors are connected to the same SSW900, install individual overload relays for each motor.

Table 3.17: Minimum and maximum current allowed

Model SSW900	Standard Connection		Inside Delta Motor Connection	
	Minimum A	Maximum A	Minimum A	Maximum A
10 A	3.0	10.0	-	-
17 A	5.1	17.0	-	-
24 A	7.2	24.0	-	-
30 A	9.0	30.0	-	-
45 A	13.5	45.0	-	-
61 A	18.3	61.0	-	-
85 A	25.5	85.0	-	-
105 A	31.5	105.0	-	-
130 A	39.0	130.0	67.5	225.2
171 A	51.3	171.0	88.9	296.2
200 A	60.0	200.0	103.9	346.4
255 A	76.5	255.0	132.5	441.7
312 A	93.6	312.0	162.1	540.4
365 A	109.5	365.0	189.7	632.2
412 A	123.6	412.0	214.1	713.6
480 A	144.0	480.0	249.4	831.4
604 A	181.2	640.0	313.8	1046.2
670 A	201.0	670.0	348.1	1160.5
820 A	246.0	820.0	426.1	1420.3
950 A	285.0	950.0	493.6	1645.4
1100 A	330.0	1100.0	571.6	1905.3
1400 A	420.0	1400.0	727.5	2424.9

The minimum and maximum current at full load depends on the model of the SSW900, current and frame.

The SSW900 may be connected to the motor in two ways; they are presented in Item 3.2.10 and Item 3.2.11.

3.2.10. Standard Three-Wire Connection of the SSW900 to the Motor
(C3.9.2.1 = 0 = Inactive)

The standard connection allows the line current of the SSW900 to be the equal as the motor current.

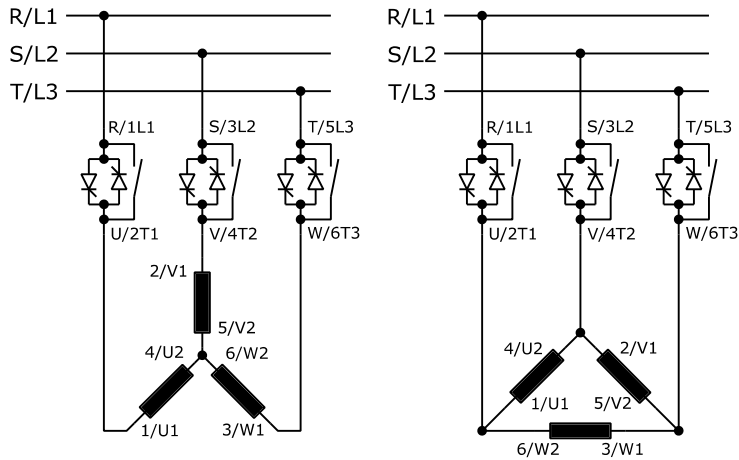

Figure 3.11: SSW900 with standard connection

3.2.11. Connection of the SSW900 Inside Delta Motor Connection Six-Cable
(C3.9.2.1 = 1 = Active)

In this type of connection, the line current of the SSW900 is equal to approximately 58 % of the motor rated current.

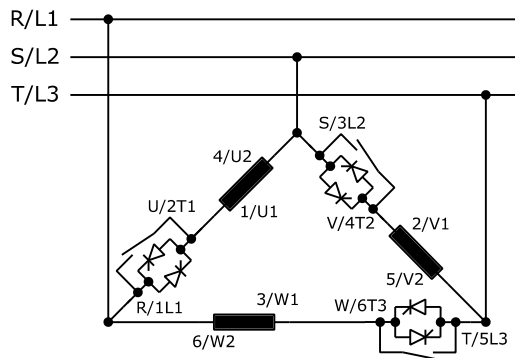

Figure 3.12: SSW900 inside delta motor connection with motor in delta

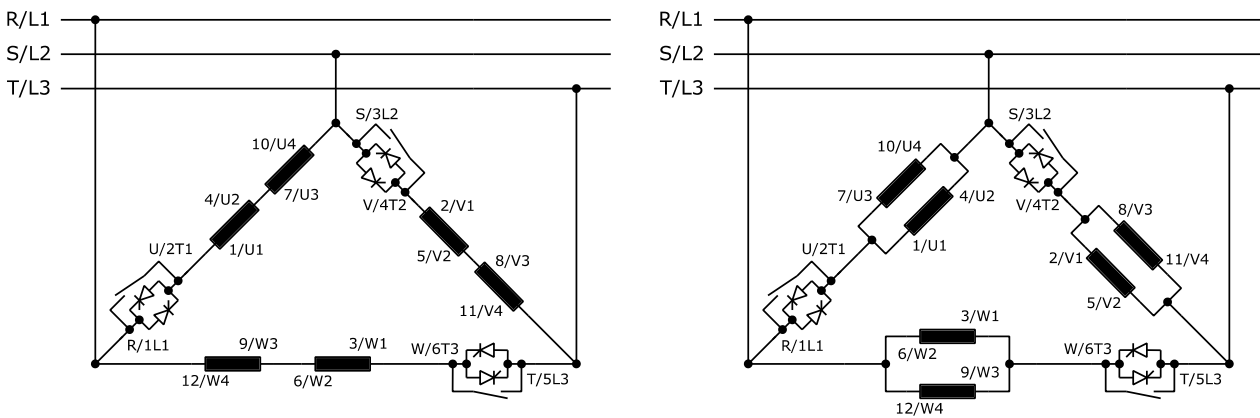

Figure 3.13: SSW900 inside delta motor connection with double delta

ATTENTION!

Check if the model of your SSW900 allows inside delta motor connection. Models below 130 A do not allow it.

ATTENTION!

For the inside delta motor connection, the motor must have delta connection capacity in the desired voltage.

ATTENTION!

The permitted three-phase voltage value of the power is reduced for inside delta motor connection:

T5 = 220 a 575 V standard connection, T5 = 220 a 500 V inside delta motor connection

T6 = 380 a 690 V standard connection, T6 = 380 a 575 V inside delta motor connection

NOTES!

1. In the inside delta motor connection, the connecting cables of the SSW900, the supply line, fuses and/or contactor for power line isolation must withstand the motor rated current. The cables that connect the motor to the SSW900 and/or connect the external bypass contactor must withstand 58 % of the motor rated current.
2. For this type of connection, it is also suggested the use of copper busbars in the connection of the SSW900 to the supply line, due to the high currents involved and cable gauges.
3. During the motor start, the motor current ratio to the SSW900 is 1.50. However, at full voltage (after the motor start) the current ratio is 1.73.

ATTENTION!

Special attention must be given to the connection of the motor to the SSW900; observe the wiring diagram shown in the figures above, according to the motor windings.

If it is necessary to invert the direction of rotation of the motor, invert only the connections of the SSW900 to the supply line.

Keep the electronics off during the connection changes.

ATTENTION!

Do not start the motor with the content of parameter C9.2.1 incorrectly set.

If the setting of this parameter is wrong, the SSW900 can get be damaged.

Table 3.18: Connection of the SSW900 to the motor

C9.2.1	Action
0 (Inactive)	SSW900 with standard connection to the motor
1 (Active)	SSW900 inside delta motor connection

3.2.12. Grounding Connections

**DANGER!**

The SSWs must be grounded for safety purposes (PE).
The ground connection must comply with the local regulations. Make the ground connection to a grounding bar or to the general grounding point (resistance ≤ 10 ohms).
Frames A and D - Control Supply pin 3.
Frames B and C – Control Supply pin 3 and heatsink terminal must be grounding.
Frames E, F and G – Control Supply pin 3 and metallic frame must be grounding.

**DANGER!**

The main power supply must have a ground connection.

**DANGER!**

Do not use the neutral for grounding purpose. Use dedicated ground conductor.

**ATTENTION!**

Do not share the grounding wiring with other equipment that operate with high currents (for examples: high voltage motors, welding machines, etc.). When several SSW900 are used, observe the connections in Figure 3.12: Grounding connections for more than one SSW900.

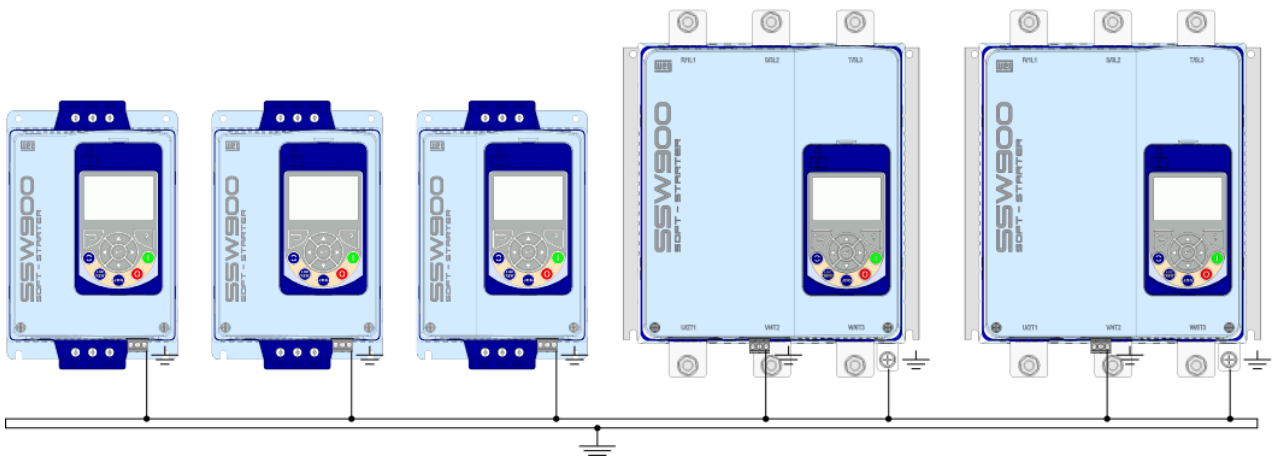

Figure 3.14: Grounding connections for more than one SSW900

EMI - Electromagnetic Interference

The SSW900 is developed to be used in industrial systems (Class A), according to standard EN60947-4-2. It's necessary to have a distance of 0.25 m (10 in) between the SSW900 control cables and motor cables. Example: PLC wiring, temperature controllers, thermocouple cables, etc.

Motor Frame Grounding

Always ground the motor frame. The SSW900 output wiring to the motor must be installed separately from the line input wiring, as well as from the control and signal wiring.

3.2.13. User's Signal and Control Connections

It is necessary to remove the HMI and the front cover to access the control terminals.

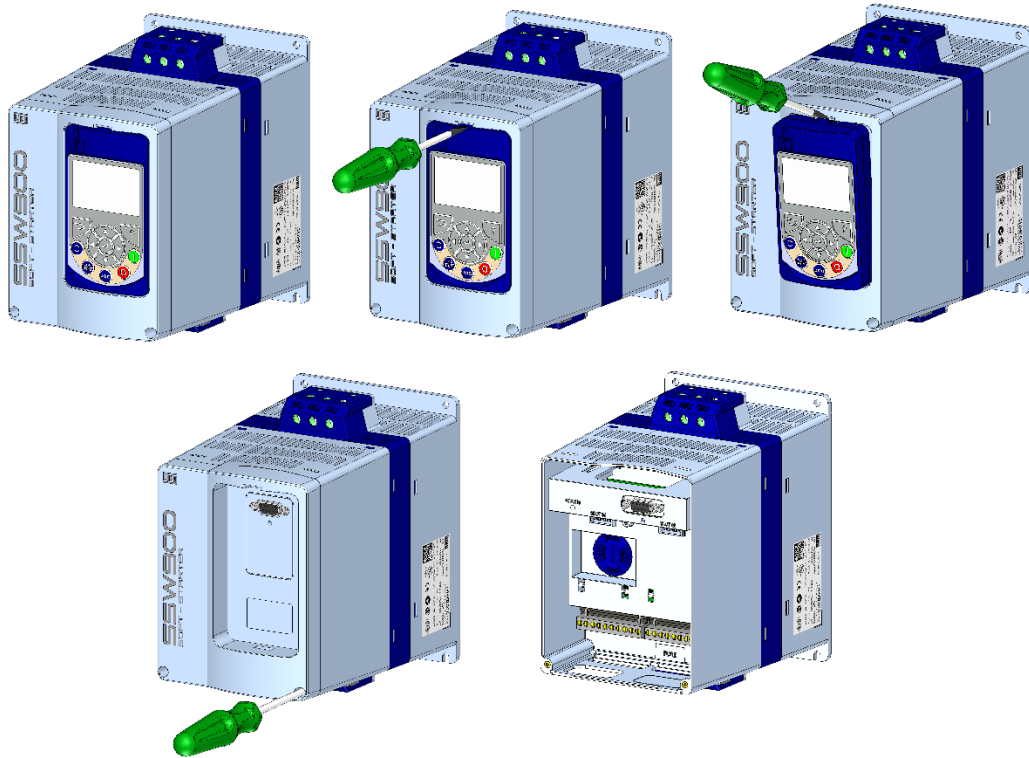

Figure 3.15: Removal of the HMI and front cover

Control power supply connections:

Control Supply		Description	Specification
	1 Phase	Control power supply	Models from 10 A to 200 A: E2 = 110 to 240 V (-15 % to +10 %), or 93.5 to 264 Vac Models from 255 to 1400 A: E3 = 110 to 130 V (-15 % to +10 %), or 93.5 to 143 Vac, or E4 = 220 to 240 V (-15 % to +10 %), or 187 to 264 Vac
	2 Neutral		
	3 Ground		

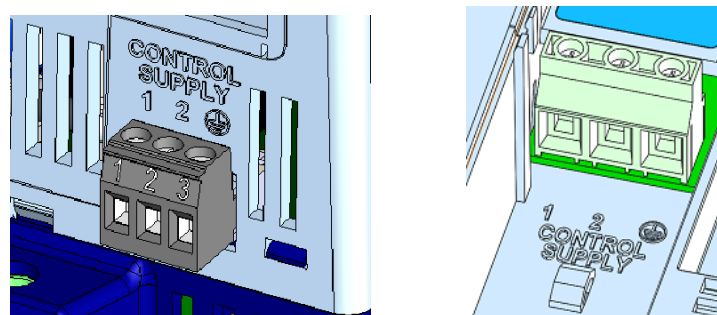

Figure 3.16: Power supply connector of the electronics

Signal (analog outputs) and control (digital inputs and outputs) connections:

Control	Factory default function	Specification
1 AO	Analog output Not used	Voltage or current output configurable by software. Resolution: 10 bits Voltage: 0 to 10 V, $R_L = 10\text{ k}\Omega$ (Maximum load) Current: 0 to 20 mA $R_L = 500\ \Omega$ (Minimum load).
2 AGND		
3 Ground		
4 PTCB	Input for the motor PTC Not used	Actuation: $3\text{ k}\Omega$ Release: $1\text{ k}\Omega$ Minimum resistance : 100Ω
5 PTCA		
6 DI1	Start (3 Wires)	5 Isolated digital inputs Minimum high level: 18 V Maximum low level: 3 V Maximum voltage: 30 V Input current: 11 mA @ 24 Vdc
7 DI2	Stop (3 Wires)	
8 DI3	Not used	
9 DI4	Not used	
10 DI5	Not used	
11 0V	Reference 0 V – DIs	Use the digital inputs only
12 COM	Common point - DIs	
13 24V	Reference 24 V – DIs	
14 RL1C	In operation	3 relay outputs Capacity of the contacts: 2 A / 240 Vac, PF = 0.6 2 A / 30 Vdc
15 RL1NO		
16 RL2C	Bypass	
17 RL2NO		
18 RL3NO	With fault	
19 RL3C		
20 RL3NC		

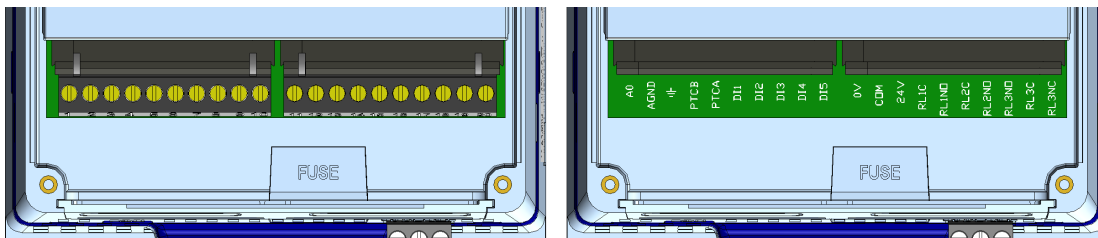
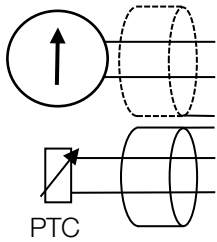

Figure 3.17: Position of the connections on the control board

In the installation of signal and control wiring, the following care must be taken:

- The digital inputs of the SSW900 allow several types of electrical connections. They can be supplied by an internal auxiliary power supply of +24 Vdc using the 0 V as common point or the +24 Vdc. They can also be supplied via an external power supply of +24 Vdc, connection with PLCs, using the 0 V as common point or the +24 Vdc according to the needs of the application:

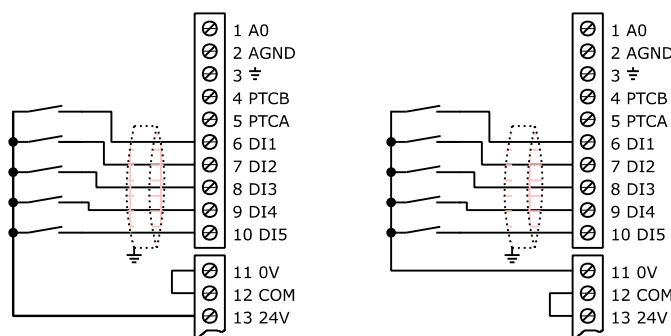

Figure 3.18: Wiring diagram of the digital inputs using internal power supply

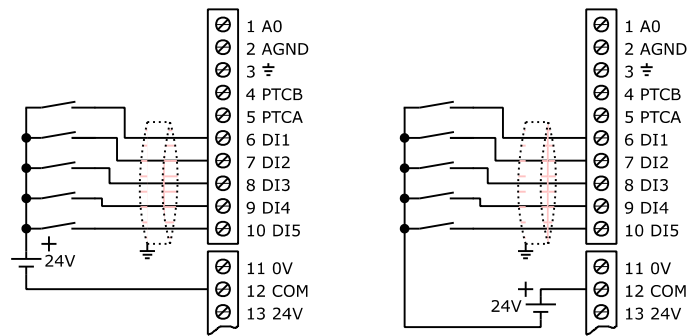

Figure 3.19: Wiring diagram of the digital inputs using external power supply

- The auxiliary power supply of the SSW900 of +24 Vdc must be used to supply the digital inputs only.
- The SSW900 comes from the factory with pins 11 and 12 of the control terminal connected (wire jumper).
- Gauge of the cables: 0.5 mm² (20 AWG) to 1.5 mm² (14 AWG).
- Maximum torque: 0.5 Nm (4.50 lbf.in).
- Wiring on the control terminals must be done with shielded cables and separated from the other wiring (power, command in 110/220 V, etc.), as follows:

Table 3.19: Wiring separation distance

Wiring Length	Minimum Separation Distance
≤ 30 m (100 ft)	≥ 10 cm (3.94 in)
> 30 m (100 ft)	≥ 25 cm (9.84 in)

If those cables must cross other cables, it must be done perpendicularly, keeping the minimum separation distance of 5 cm at the crossing point.

Connect the shield as follows:

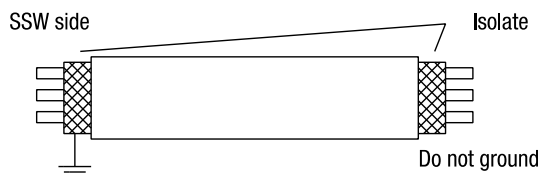

Figure 3.20: Connection of the shield

- Relays, contactors and solenoids installed near the SSW900 may occasionally generate interference in the control circuitry. To eliminate this effect, RC suppressors must be connected in parallel to the coils of these devices in case of AC power supply, and freewheel diodes in case of DC power supply.
- When an external HMI is used, you must be careful to keep the cable that connects it to the SSW900 at least 10 cm (3.94 in) away from the other cables present in the installation.

Fan connection

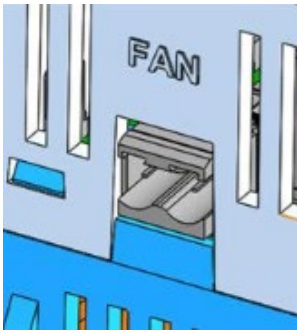

Figure 3.21: Ventilation kit connector

The frames B and C (45 A to 200 A) have a connector (FAN) for installing the Ventilation Kit. For more details see Chapter 6.

**ATTENTION!**

This connector is only available in frames B and C, and should only be used to connect the Ventilation Kit.

3.3.INSTALLATION IN COMPLIANCE WITH STANDARD EN60947-4-2

In order to install the SSW900 in compliance with standard EN60947-4-2 it is necessary to meet the following requirements:

1. The cables used for the control (inputs and outputs) and signal wiring must be shielded or run in metallic conduits or channels with equivalent attenuation.
2. It is essential to follow the grounding recommendations presented in this manual.
3. The SSW900 is classified for use in "Class A", individual use and without requiring external filters or shielded power cables.

Description of the conducted emission class according to standard EN60947-4-2 (2000) + A1 (2002):

Class B: residential environment (first environment), unrestricted distribution.

Class A: industrial environment (second environment), unrestricted distribution.

3.4.RECOMMENDED SET-UPS

Some recommended set-ups are presented and it can be completely or partly used.

The main warning notes for all the recommended set-ups are also informed and are described in the schemes by their respective numbers.

	Contactor		Normally open (NO) push-button		SSW900 Power circuit
	Switch-disconnector		Normally closed (NC) push-button		Motor with 6 cables
	Fuse-switch-disconnector		Normally open (NO) switch		Motor with 3 cables
	Motor circuit-breaker		Motor RTD Sensor		SSW900 power supply connector
	Circuit-breaker		Shunt trip with snubber		SSW900 control connector
	Fuse		Contactor bobbin with snubber		

Figure 3.22: Symboly

3.4.1. Commands via HMI and Power Isolation Contactor

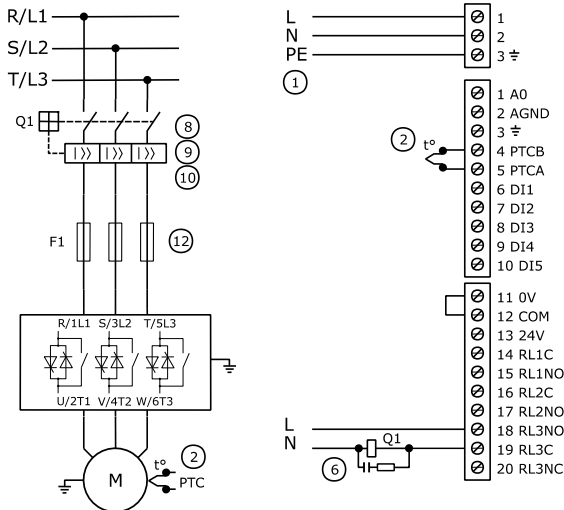

Commands via HMI

C3 - LOC/REM Selection
 C3.1 = 0
 (Mode = Always LOC)
 C3.2 = 0
 (LOC Command = HMI Keys)

C4 - I/O
 C4.2.3 = 14
 (DO3 = Breaker Shunt Trip)

NOTES!

- ① Check the electronics power supply. "Control Supply" connector.
- ② Optional. It is recommended to use a PTC, thermostat connected to a digital input programmed for external fault or PT100 accessory.
- ⑥ Use a digital output programmed for "Breaker Shunt Trip" fault to open the circuit breaker when a fault occurs on the power circuit of the SSW.
- ⑧ In case of maintenance on the SSW or on the motor, it is necessary to disconnect the power supply input so as to ensure the full disconnection of the equipment from the supply line.
- ⑨ In case of damages on the power circuit of the SSW which keep the motor running by short circuit, the motor protection is obtained by using the power isolation contactor (K1) or circuit breaker (Q1) controlled by the SSW.
- ⑩ Coordination Type 1 – use a circuit breaker for short circuit protection on the input circuit. Use a shunt trip on the circuit breaker to open the circuit breaker via digital output of the SSW.
- ⑫ Optional. Coordination Type 2 – use aR ultra-fast fuses for semiconductor protection.

3.4.2. Commands via Digital Inputs and Power Isolation Circuit Breaker

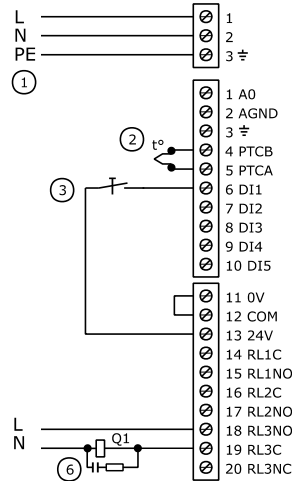
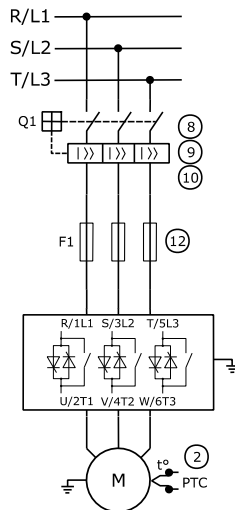
Commands 2 wires

C3 - LOC/REM Selection

C3.1 = 0

(Mode = Always LOC)

C3.2 = 1

(LOC Command= DIx)

C4 - I/O

C4.1.1 = 1

(DI1 = Start / Stop)

C4.2.3 = 14

(DO3 = Breaker Shunt Trip)

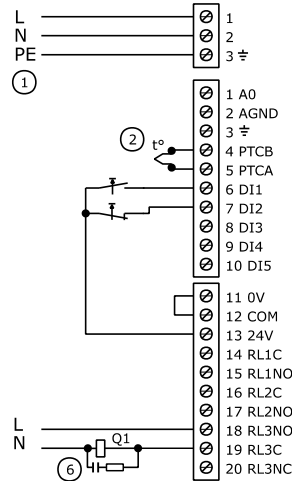
Commands 3 wires

C3 - LOC/REM Selection

C3.1 = 0

(Mode = Always LOC)

C3.2 = 1

(LOC Command= DIx)

C4 - I/O

C4.1.1 = 2

(DI1 = Start 3 Wires)

C4.1.2 = 3

(DI2 = Stop 3 Wires)

C4.2.3 = 14

(DO3 = Breaker Shunt Trip)

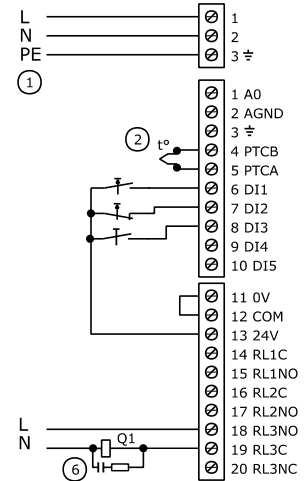
Commands 3 wires and LOC/REM

C3 - LOC/REM Selection

C3.1 = 4

(Mode = DIx)

C3.2 = 0

(LOC Command= DIx)

C3.3 = X

(REM Command= X)

C4 - I/O

C4.1.1 = 2

(DI1 = Start 3 Wires)

C4.1.2 = 3

(DI2 = Stop 3 Wires)

C4.1.3 = 5

(DI3 = LOC/ REM)

C4.2.3 = 14

(DO3 = Breaker Shunt Trip)

NOTES!

- ① Check the electronics power supply. "Control Supply" connector.
- ② Optional. It is recommended to use a PTC, thermostat connected to a digital input programmed for external fault or PT100 accessory.
- ③ Start/Stop switch: remember that when a command via two-wire digital input is used, when the power is restored after a power failure, the motor starts immediately if the switch remains closed.
- ⑥ Use a digital output programmed for "Breaker Shunt Trip" fault to open the circuit breaker when a fault occurs on the power circuit of the SSW.
- ⑧ In case of maintenance on the SSW or on the motor, it is necessary to disconnect the power supply input so as to ensure the full disconnection of the equipment from the supply line.
- ⑨ In case of damages on the power circuit of the SSW which keep the motor running by short circuit, the motor protection is obtained by using the power isolation contactor (K1) or circuit breaker (Q1) controlled by the SSW.
- ⑩ Coordination Type 1 – use a circuit breaker for short circuit protection on the input circuit. Use a shunt trip on the circuit breaker to open the circuit breaker via digital output of the SSW.
- ⑫ Optional. Coordination Type 2 – use aR ultra-fast fuses for semiconductor protection.

3.4.3. Commands via Digital Inputs and Power Isolation Contactor

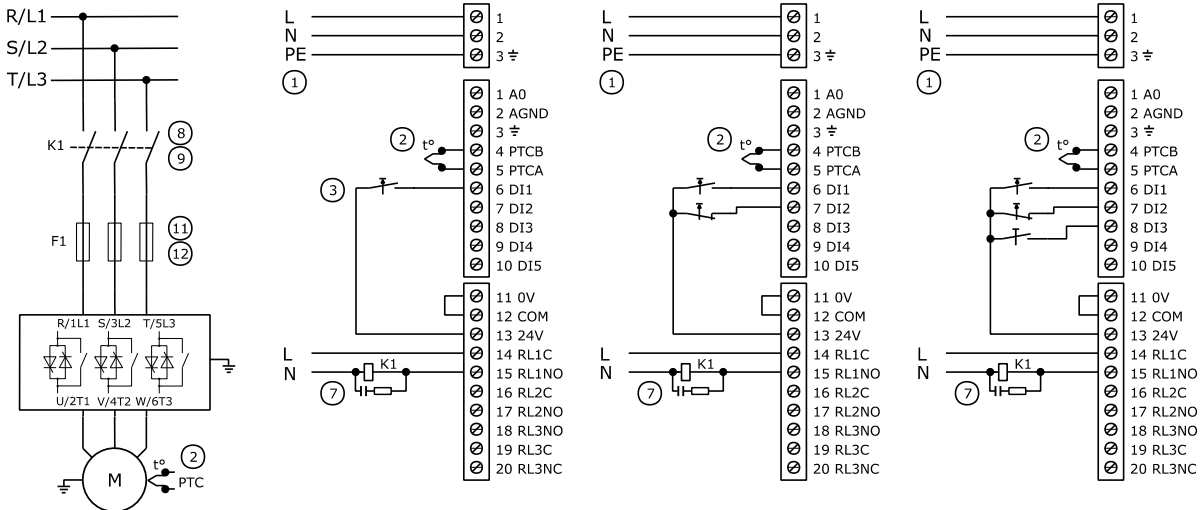

Commands 2 wires

C3 - LOC/REM Selection
 C3.1 = 0
 (Mode = Always LOC)
 C3.2 = 1
 (LOC Command= DIx)

C4 - I/O
 C4.1.1 = 1
 (DI1 = Start / Stop)
 C4.2.1 = 1
 (DO1 = Running)

Commands 3 wires

C3 - LOC/REM Selection
 C3.1 = 0
 (Mode = Always LOC)
 C3.2 = 1
 (LOC Command= DIx)

C4 - I/O
 C4.1.1 = 2
 (DI1 = Start 3 Wires)
 C4.1.2 = 3
 (DI2 = Stop 3 Wires)
 C4.2.1 = 1
 (DO1 = Running)

Commands 3 wires and LOC/REM

C3 - LOC/REM Selection
 C3.1 = 4
 (Mode = DIx)
 C3.2 = 0
 (LOC Command= DIx)
 C3.3 = X
 (REM Command= X)

C4 - I/O
 C4.1.1 = 2
 (DI1 = Start 3 Wires)
 C4.1.2 = 3
 (DI2 = Stop 3 Wires)
 C4.1.3 = 5
 (DI3 = LOC/ REM)
 C4.2.1 = 1
 (DO1 = Running)

NOTES!

- ① Check the electronics power supply. "Control Supply" connector.
- ② Optional. It is recommended to use a PTC, thermostat connected to a digital input programmed for external fault or PT100 accessory.
- ③ Start/Stop switch: remember that when a command via two-wire digital input is used, when the power is restored after a power failure, the motor starts immediately if the switch remains closed.
- ⑦ Use a digital output programmed for "Running" to control the input contactor.
- ⑧ In case of maintenance on the SSW or on the motor, it is necessary to disconnect the power supply input so as to ensure the full disconnection of the equipment from the supply line.
- ⑨ In case of damages on the power circuit of the SSW which keep the motor running by short circuit, the motor protection is obtained by using the power isolation contactor (K1) or circuit breaker (Q1) controlled by the SSW.
- ⑪ Coordination Type 1 – use regular fuses for short circuit protection on the input circuit.
- ⑫ Optional. Coordination Type 2 – use aR ultra-fast fuses for semiconductor protection.

3.4.4. Commands via Digital Inputs and Inside Delta Motor Connection

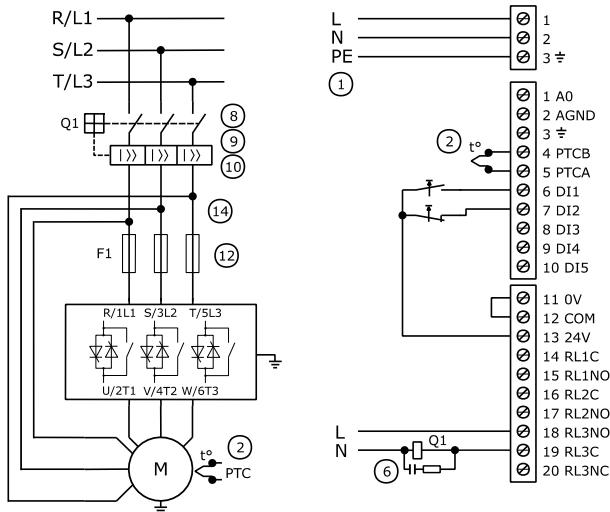
Inside Delta Motor Connection Commands 3 wires

C9 – SSW900
C9.2.1 = 1
(Delta Inside= On)

C3 - LOC/REM Selection
C3.1 = 0
(Mode = Always LOC)
C3.2 = 1
(LOC Command = DIx)

C4 - I/O
C4.1.1 = 2
(DI1 = Start 3 Wires)
C4.1.2 = 3
(DI2 = Stop 3 Wires)
C4.2.3 = 14
(DO3 = Breaker Shunt Trip)

NOTES!

- ① Check the electronics power supply. "Control Supply" connector.
- ② Optional. It is recommended to use a PTC, thermostat connected to a digital input programmed for external fault or PT100 accessory.
- ⑥ Use a digital output programmed for "Breaker Shunt Trip" fault to open the circuit breaker when a fault occurs on the power circuit of the SSW.
- ⑧ In case of maintenance on the SSW or on the motor, it is necessary to disconnect the power supply input so as to ensure the full disconnection of the equipment from the supply line.
- ⑨ In case of damages on the power circuit of the SSW which keep the motor running by short circuit, the motor protection is obtained by using the power isolation contactor (K1) or circuit breaker (Q1) controlled by the SSW.
- ⑩ Coordination Type 1 – use a circuit breaker for short circuit protection on the input circuit. Use a shunt trip on the circuit breaker to open the circuit breaker via digital output of the SSW.
- ⑫ Optional. Coordination Type 2 – use aR ultra-fast fuses for semiconductor protection.
- ⑭ Use "terminal blocks" to shunt the power cables.

3.4.5. Commands via Digital Inputs and External Bypass Contactor

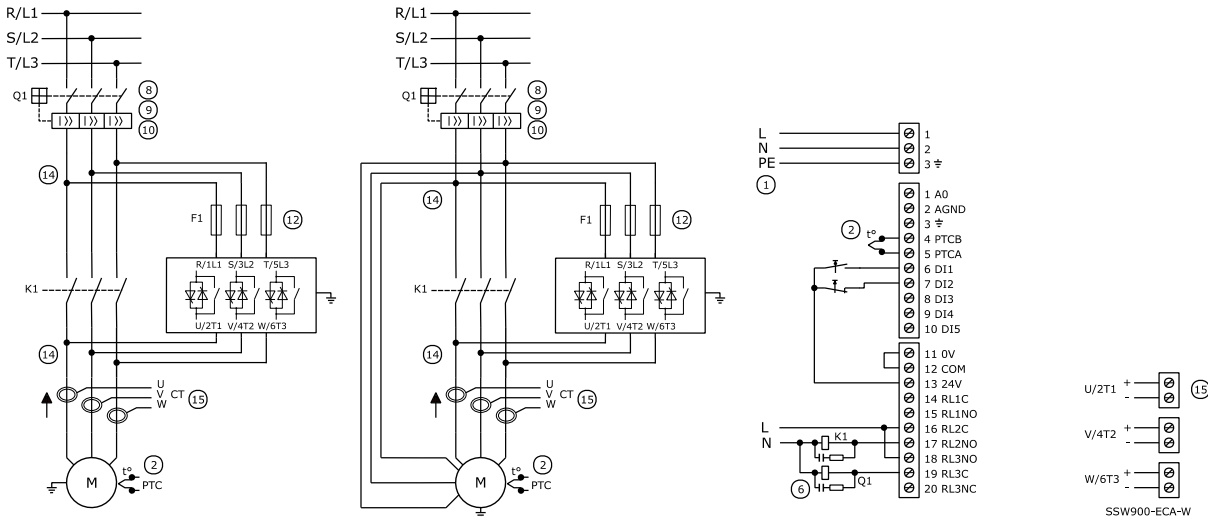

Standard Connection

C9 – SSW900
 C9.2.1 = 0
 (Delta Inside= Off)

Inside Delta Motor Connection

C9 – SSW900
 C9.2.1 = 1
 (Delta Inside = On)

Comands 3 wires

C3 - LOC/REM Selection
 C3.1 = 0
 (Mode = Always LOC)
 C3.2 = 1
 (LOC Command = DIx)

Slot 1 or 2

C4 - I/O
 C4.1.1 = 2
 (DI1 = Start 3 Wires)
 C4.1.2 = 3
 (DI2 = Stop 3 Wires)
 C4.2.2 = 3
 (DO2 = Bypass)
 C4.2.3 = 14
 (DO3 = Breaker Shunt Trip)

NOTES!

- ① Check the electronics power supply. "Control Supply" connector.
- ② Optional. It is recommended to use a PTC, thermostat connected to a digital input programmed for external fault or PT100 accessory.
- ⑥ Use a digital output programmed for "Breaker Shunt Trip" fault to open the circuit breaker when a fault occurs on the power circuit of the SSW.
- ⑧ In case of maintenance on the SSW or on the motor, it is necessary to disconnect the power supply input so as to ensure the full disconnection of the equipment from the supply line.
- ⑨ In case of damages on the power circuit of the SSW which keep the motor running by short circuit, the motor protection is obtained by using the power isolation contactor (K1) or circuit breaker (Q1) controlled by the SSW.
- ⑩ Coordination Type 1 – use a circuit breaker for short circuit protection on the input circuit. Use a shunt trip on the circuit breaker to open the circuit breaker via digital output of the SSW.
- ⑫ Optional. Coordination Type 2 – use aR ultra-fast speed fuses for semiconductor protection.
- ⑭ Use "terminal blocks" to shunt the power cables.
- ⑮ When using an external bypass contactor, on models up to 412 A, use the "SSW900-KECA-xxx" accessory to keep the current protections and readings.

3.4.6. Commands via Digital Inputs, Optimal Braking and DC Braking

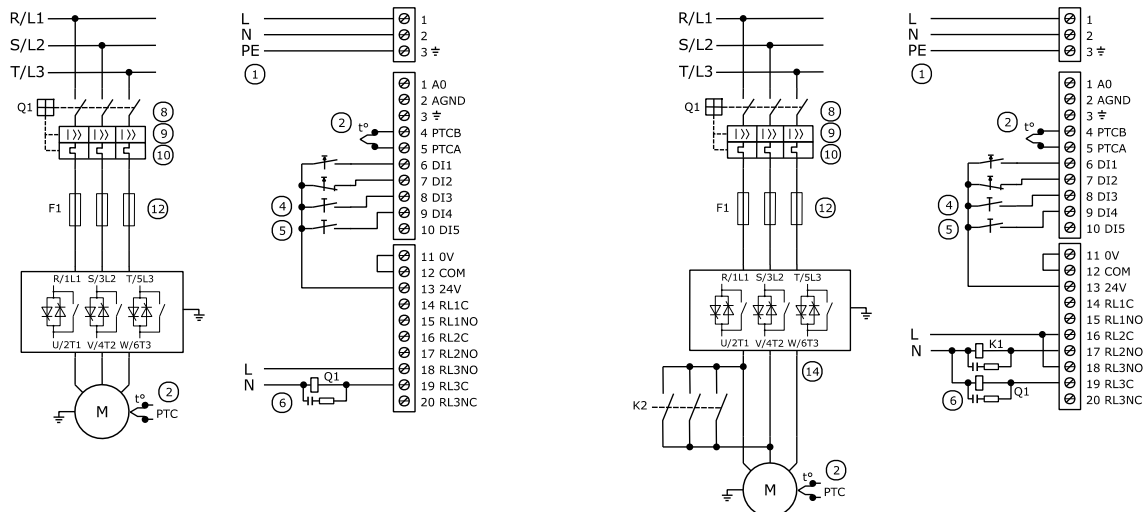
Optimal Braking

C7 – Special Functions
C7.4.1 = 2
(Mode = Optimal)

Commands 3 wires

C3 - LOC/REM Selection
C3.1 = 0
(Mode = Always LOC)
C3.2 = 1
(LOC Command = DIx)

C4 - I/O
C4.1.1 = 2
(DI1 = Start 3 Wires)
C4.1.2 = 3
(DI2 = Stop 3 Wires)
C4.1.3 = 4
(DI3 = General Enable)
C4.1.4 = 10
(DI4 = Brake)
C4.2.3 = 14
(DO3 = Breaker Shunt Trip)

DC Braking

C7 – Special Functions
C7.4.1 = 3
(Mode = DC)

Commands 3 wires

C3 - LOC/REM Selection
C3.1 = 0
(Mode = Always LOC)
C3.2 = 1
(LOC Command = DIx)

C4 - I/O
C4.1.1 = 2
(DI1 = Start 3 Wires)
C4.1.2 = 3
(DI2 = Stop 3 Wires)
C4.1.3 = 4
(DI3 = General Enable)
C4.1.4 = 10
(DI4 = Brake)
C4.2.2 = 5
(DO2 = DC Braking)
C4.2.3 = 14
(DO3 = Breaker Shunt Trip)

NOTES!

- ① Check the electronics power supply. "Control Supply" connector.
- ② Optional. It is recommended to use a PTC, thermostat connected to a digital input programmed for external fault or PT100 accessory.
- ④ Use a digital input programmed as "General Enable" to stop the motor without the braking.
- ⑤ For safety reasons, use a digital input programmed as "Braking", with the possibility to install a motor stop sensor.
- ⑥ Use a digital output programmed for "Breaker Shunt Trip" fault to open the circuit breaker when a fault occurs on the power circuit of the SSW.
- ⑧ In case of maintenance on the SSW or on the motor, it is necessary to disconnect the power supply input so as to ensure the full disconnection of the equipment from the supply line.
- ⑨ In case of damages on the power circuit of the SSW which keep the motor running by short circuit, the motor protection is obtained by using the power isolation contactor (K1) or circuit breaker (Q1) controlled by the SSW.
- ⑩ Coordination Type 1 – use a circuit breaker for short circuit protection on the input circuit. Use a shunt trip on the circuit breaker to open the circuit breaker via digital output of the SSW.
- ⑫ Optional. Coordination Type 2 – use aR ultra-fast speed fuses for semiconductor protection.

3.4.7. Command via Digital Inputs and Reverse Braking

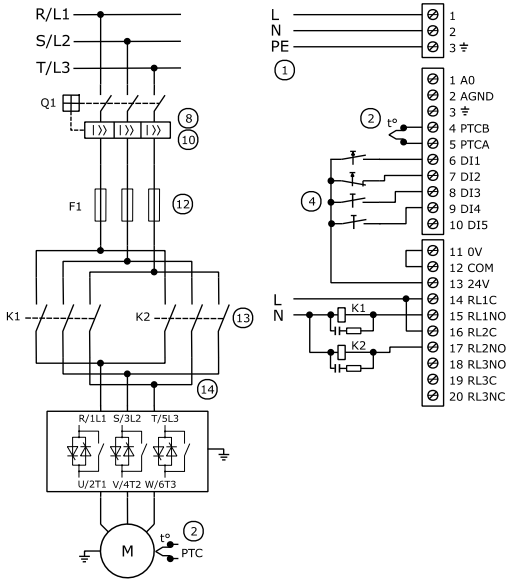

Reverse Braking

C7 – Special Functions
 C7.4.1 = 1
 (Mode = Reverse)

Commands 3 wires

C3 - LOC/REM Selection
 C3.1 = 0
 (Mode = Always LOC)
 C3.2 = 1
 (LOC Command = DIx)

C4 - I/O
 C4.1.1 = 2
 (DI1 = Start 3 Wires)
 C4.1.2 = 3
 (DI2 = Stop 3 Wires)
 C4.1.3 = 4
 (DI3 = General Enable)
 C4.1.4 = 10
 (DI4 = Brake)
 C4.2.1 = 4
 (DO1 = FWD / REV K1)
 C4.2.2 = 4
 (DO2 = FWD / REV K2)

NOTES!

- ① Check the electronics power supply. "Control Supply" connector.
- ② Optional. It is recommended to use a PTC, thermostat connected to a digital input programmed for external fault or PT100 accessory.
- ④ Use a digital input programmed as "General Enable" to stop the motor without the braking.
- ⑤ For safety reasons, use a digital input programmed as "Braking", with the possibility to install a motor stop sensor.
- ⑧ In case of maintenance on the SSW or on the motor, it is necessary to disconnect the power supply input so as to ensure the full disconnection of the equipment from the supply line.
- ⑩ Coordination Type 1 – use a circuit breaker for short circuit protection on the input circuit. Use a shunt trip on the circuit breaker to open the circuit breaker via digital output of the SSW.
- ⑫ Optional. Coordination Type 2 – use aR ultra-fast speed fuses for semiconductor protection.
- ⑬ The contactors must be of the same model and withstand the motor starting current, AC3. For safety reasons, the auxiliary contacts must be used in order to prevent the two contactors from closing at the same time.
- ⑭ Use "terminal blocks" to shunt the power cables.

3.4.8. Command via Digital Inputs and Change of Direction of Rotation

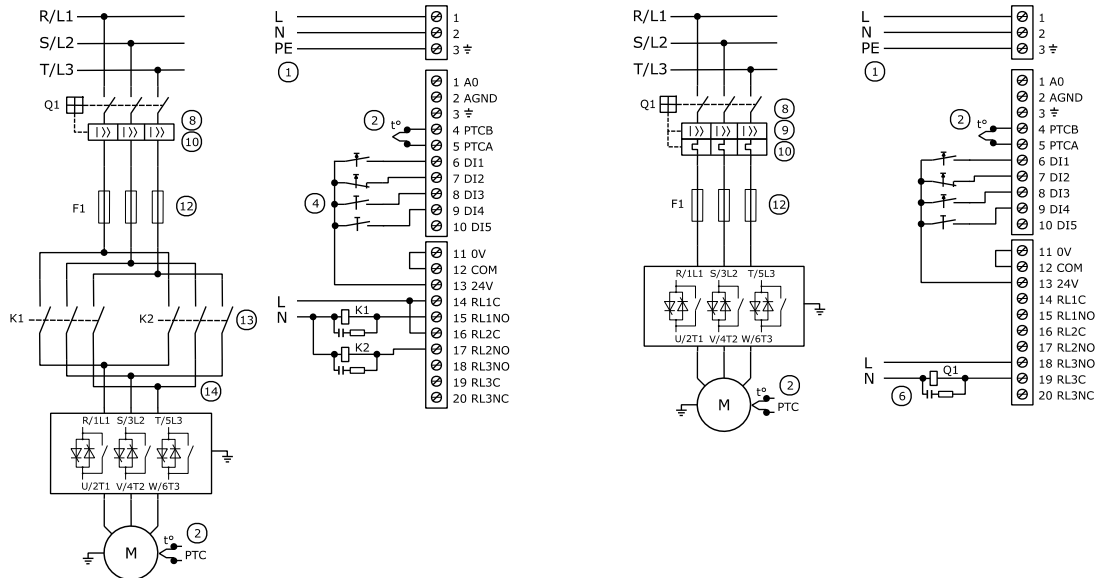
Via Direction of Rotation

C7 – Special Functions
C7.1.1 = 1
(Mode = Via Contactor)

Commands 3 wires

C3 - LOC/REM Selection
C3.1 = 0
(Mode = Always LOC)
C3.2 = 1
(LOC Command = DIx)

C4 - I/O
C4.1.1 = 2
(DI1 = Start 3 Wires)
C4.1.2 = 3
(DI2 = Stop 3 Wires)
C4.1.4 = 7
(DI4 = FWD / REV)
C4.2.1 = 4
(DO1 = FWD / REV K1)
C4.2.2 = 4
(DO2 = FWD / REV K2)

Via JOG

C7 – Special Functions
C7.1.1 = 2
(Mode = Only for JOG)

C7.3.1 = 1
(Mode = On)

Commands 3 wires

C3 - LOC/REM Selection
C3.1 = 0
(Mode = Always LOC)
C3.2 = 1
(LOC Command = DIx)

C4 - I/O
C4.1.1 = 2
(DI1 = Start 3 Wires)
C4.1.2 = 3
(DI2 = Stop 3 Wires)
C4.1.3 = 6
(DI3 = JOG)
C4.1.4 = 7
(DI4 = FWD / REV)
C4.2.3 = 14
(DO3 = Breaker Shunt Trip)

NOTES!

- ① Check the electronics power supply. "Control Supply" connector.
- ② Optional. It is recommended to use a PTC, thermostat connected to a digital input programmed for external fault or PT100 accessory.
- ⑥ Use a digital output programmed for "Breaker Shunt Trip" fault to open the circuit breaker when a fault occurs on the power circuit of the SSW.
- ⑧ In case of maintenance on the SSW or on the motor, it is necessary to disconnect the power supply input so as to ensure the full disconnection of the equipment from the supply line.
- ⑨ In case of damages on the power circuit of the SSW which keep the motor running by short circuit, the motor protection is obtained by using the power isolation contactor (K1) or circuit breaker (Q1) controlled by the SSW.
- ⑩ Coordination Type 1 – use a circuit breaker for short circuit protection on the input circuit. Use a shunt trip on the circuit breaker to open the circuit breaker via digital output of the SSW.
- ⑫ Optional. Coordination Type 2 – use aR ultra-fast speed fuses for semiconductor protection.
- ⑬ The contactors must be of the same model and withstand the motor starting current, AC3. For safety reasons, the auxiliary contacts must be used in order to prevent the two contactors from closing at the same time.
- ⑭ Use "terminal blocks" to shunt the power cables.

4 POWER-UP AND START-UP

This chapter explains:

- How to inspect and prepare the SSW900 before powering up.
- How to successfully power up the unit.
- How to operate the SSW900 when installed according to the typical drives (see Chapter 3).

4.1.POWER-UP PREPARATION

The SSW900 must first be installed according to Chapter 3. If the drive project is different from the typical setup suggested, the steps below may also be followed.



DANGER!

Always disconnect the main power supply before making any connections.

1. Check all the connections: Check if the power, grounding and control connections are correct and firm.
2. Clean the SSW900 inner connection area: Remove all the materials left inside the SSW900 or drive.
3. Check the correct voltage selection: In the models from 255 A to 1400 A, the voltage of the electronics power supply must be checked, E3 or E4.
4. Check the motor: Check the motor connections and if the motor voltage and current are according to the SSW900.
5. Check the connection type of the SSW900 to the motor: If the connection to be used is the standard three-wire connection or inside delta motor connection with six cables. More details in Chapter 3.2.
6. Mechanically uncouple the motor from the load: If the motor cannot be uncoupled, make sure that any spin in any direction (forward or reverse) will not result in personal risk and/or equipment damage.
7. Close the SSW900 covers.

4.2.INITIAL POWER-UP

After the proper preparation, the SSW900 may be powered up:

1. Check the supply voltage. The line voltage must be within the allowed range (Rated voltage -15 % to +10 %).
2. Power up the electronics supply.



ATTENTION!

Always energize the electronics supply before energizing the power, and make all the adjustments contained in this Chapter.

3. Check the result of the power-up:
4. Run the Oriented Start-up function.
Conform Chapter 12 of the SSW900 Programming Manual.
The parameter to run the Oriented Start-up is in the Assistant menu. Set parameter A1 (Oriented Start-up) to 1 = Yes.

**NOTES!**

For further details on the operation and programming of the HMI, see Chapter 8 of the SSW900 Programming Manual.
For details on typical applications, see Chapter 13 of the SSW900 Programming Manual.

**ATTENTION!**

It is essential to have at hand the catalog or motor plate data of the motor to be used. Those data are necessary to properly set the motor data and protection parameters.

**ATTENTION!**

The protection Thermal Class of the motor must be set so as to protect the motor against overloads during the start and full operating duty. For details about the setting of the Thermal Class, see the Programming Manual.

**ATTENTION!**

In the adjustment sequence by means of the Oriented Start-up are only the main parameters for learning the operation of the SSW900. Before putting it at full operating duty, all the necessary parameters for the perfect operation of the SSW900 and motor protection must be set.

4.3.START-UP

If the first parameterization by means of the Oriented Start-up is satisfactory, first, with the motor uncoupled from the load, make an operation test by starting the motor.

1. Initially you can use the voltage ramp control plus current limit to start the motor, with long starting times ($C1.3 \approx 20$ s) and low initial voltages ($C1.2 \approx 30$ %), so as to minimize the starting currents. For details on the control methods to be used, refer to the Chapter Programming Suggestions of the Programming Manual.
2. Before coupling the motor to the load, check the direction of rotation of the motor shaft. Program the protections according to the application requirements. For further details, refer to the Programming Manual.
3. Use a thermal protection method for the motor.
4. Couple the motor shaft to the load. Energize the power and start the motor.
5. The data of this start can be checked by using the diagnosis parameters, such as maximum starting current, average starting current, real starting time. Refer to the Chapter Diagnosis in the Programming Manual.
6. Based on the diagnosis data, it is possible to adjust the best programming to be used in the next starts under full operating duty.

**ATTENTION!**

Special attention to the starting limits of the SSW900:
Maximum starting times.
Maximum starting currents.
Time interval between the starts.
The noncompliance with those limits may lead to the SSW900 damage.

5 TROUBLESHOOTING AND MAINTENANCE

This chapter presents:

- The description of the actuation of faults and alarms.
- The list of the most common problems and corrective actions.
- It contains instructions for periodical inspections of the product and preventive maintenance.

5.1.ACTUATION OF PROTECTIONS, FAULTS AND ALARMS

When fault "FXXX" is identified, what occurs is:

- Bypass opens.
- SCR's are stopped and blocked..
- Indication on the display of the fault description and code.
- Indication in the present fault in D1.1.1.
- Indication in the logical status word in S3.1.3.1.
- The relay programmed for "NO FAULTS" is turned off.

For the SSW900 to go back to normal operation right after the occurrence of a fault, it is necessary to reset it, which can be done as follows:

- Pressing the key  (manual reset).
- Via soft key "Reset".
- Automatically by setting C5.11.1 (auto-reset).
- Via digital input: (C4.1.1 to C4.1.6) DIx = 11 (Reset).
- Switching off the power supply, and switching it back on (power-on reset).

When alarm "AXXX" is identified, what occurs is:

- Indication on the display of the alarm description and code.
- Indication of the alarm in D2.1.1 to D2.1.5.
- Indication in the logical status word in S3.1.3.1.
- The SCRs continue operating, bypass continue closed (when closed) and the SSW900 keeps operating. Except for the protection of the communications.

The indications are automatically removed after the system leaves the alarm condition.



NOTE!

The actuation of alarms and faults is described in the Chapter Faults and Alarms of the Programming Manual.

5.2.FREQUENT PROBLEMS

Table 5.1: Frequent problems

Problem	Probable Cause	Cause Description
The SSW900 will not respond to the commands	Fault	Indication on the HMI: "FXXX". In a fault situation, the SSW900 will not drive the motor. Check the fault. Refer to the Chapter Faults and Alarms of the Programming Manual.
	Time before the start or after the stop Time between starts.	Indication on the HMI: "Start Delay" or "Re-start Delay". The SSW900 is waiting for the time after the motor stop, set in C5.7.2. Refer to the Chapter Time Protections of the Programming Manual.
	General enable	Indication on the HMI: "Ger.Dis". General Disabled Check the command source. If some DI is set for General Enable, it may be general disable even with commands by other sources. Refer to the Chapter Digital Inputs of the Programming Manual.
	Mode Configuration	Indication on the HMI: "Config". It indicates that the SSW900 is in a special condition that cannot drive the motor. Refer to the description of parameter S5.6.1 in the Programming Manual.
	Command source LOC/REM	Check if the active command source is in Local or Remote. Indication in S3.1.2. Refer to the Chapter Local/Remote Configuration of the Programming Manual.
	Commands by HMI – Keys I,O	Check the Fault conditions, Time after Stop, General Enable, Configuration Mode and Command Source indicated on the HMI. Refer to the Chapter HMI of the Programming Manual.
	Commands by Dix – Digital inputs	Check the Fault conditions, Time after Stop, General Enable, Configuration Mode and Command Source indicated on the HMI. Check the drive types, two wires, three wires. Check the connections of the digital inputs, Dix, 24V and COM. Refer to 3.2.13 - User's Signal and Control Connections Refer to the Chapter Digital Inputs of the Programming Manual.
	Commands by USB	Check the Fault conditions, Time after Stop, General Enable, Configuration Mode and Command Source indicated on the HMI. Check the commands sent by the USB in S5.2.3. The logical status of the SSW900 can be checked in S5.1.1. Refer to the Serial Communication Manual and the description of parameters S5.1.1 and S5.2.3 in the Programming Manual.
	Commands by SLOT 1	Check the Fault conditions, Time after Stop, General Enable, Configuration Mode and Command Source indicated on the HMI. Check the commands sent by the SLOT 1 in S5.2.5. The logical status of the SSW900 can be checked in S5.1.1. Refer to the Serial Communication Manual and the description of parameters S5.1.1 and S5.2.5 in the Programming Manual.
Commands by SLOT 2	Check the Fault conditions, Time after Stop, General Enable, Configuration Mode and Command Source indicated on the HMI. Check the commands sent by the SLOT 2 in S5.2.6. The logical status of the SSW900 can be checked in S5.1.1. Refer to the Serial Communication Manual and the description of parameters S5.1.1 and S5.2.6 in the Programming Manual.	
Motor will not reach rated speed	Motor will not start	Values of Current or Torque Limit too low for the load applied to the motor.
	Motor starts	Line voltage too low or undersized transformers.
Motor speed too high or too low	Motor data	Check if the motor used is according to the application.

Problem	Probable Cause	Cause Description
Abnormal vibration in the motor stop	Applications in general	The stopping time (deceleration) must be used only in applications with centrifugal hydraulic pumps. For other applications, C1.13 must remain 0 = Inactive.
	Pumps	Stopping times too high. Deceleration control method is not suitable for the application. Refer to the Chapter Control Types and Programming Information and Suggestions of the Programming Manual.
Noise on the motor	In the start	The noise produced by the motor in the start depends on the starting method used and time involved, however, it is continuous, medium and without jolts. Wrong connection to the motor, wrong connection inside the motor delta box.
	In JOG	The JOG function of the SSW900 applies a low frequency to the motor, which produces pulsed and high noises on the motor, according to the JOG level.
	In braking	The optimal braking method produces high and discontinuous noises on the motor, becoming lower and continuous when it stops. The DC braking method produces medium and constant noises on the motor. The Reverse braking produces noises equal to the motor start, becoming the same as the noise of the optimal braking in the motor stop.
Increase of the motor current in the deceleration	Applications in general	The stopping time (deceleration) must be used only in applications with centrifugal hydraulic pumps. For other applications, C1.13 must remain 0 = Inactive.
	Pumps	It is normal in the controlled deceleration of centrifugal hydraulic pumps for the current to increase as the motor stops, because the motor is in the locked rotor state. In order to reduce such effect, you may set C1.15 to the value in % of the motor voltage at the moment of its stop. The value of the motor voltage in V at the moment of the stop may be viewed in S1.3.1. Refer to the description of parameter S5.6.1 in the Programming Manual.
HMI display OFF	Connections to the HMI	Check the cable that connects the HMI to the SSW900.
	Power supply	Check if the electronics power supply is out of the range allowed. See Figure 3.14: Power supply connector of the electronics.
	Fuse	Check the fuse of the electronics power supply. If replacement is necessary, use glass time delay fuses 5x20 mm. It is recommended to use: 0239002.P.H Littelfuse; GMD-2 A Cooper Bussmann; GGA2 Ferraz / Mersen; See Figure 5.1: Procedure to change the fuse of the electronics power supply

5.3.PREVENTIVE MAINTENANCE



DANGER!

Always disconnect the general power supply before touching any electrical component in connection with the SSW900.

High voltages may still be present even after disconnecting the power supply.

Wait for at least three minutes for the complete discharge of the electronics capacitors.

Always connect the equipment frame to the protective earth (PE) at the proper terminal.



ATTENTION!

Electronic boards have components sensitive to electrostatic discharges.

Do not touch the components or connectors directly. If necessary, first touch the grounded metallic frame or wear a ground strap.

**Do not apply any high voltage tests on the SSW900!
If necessary, contact the manufacturer.**

Do not use Isolation testers - Meggers - to test the thyristors.

Periodic inspections of SSW900 and installations are necessary to avoid operating problems due to environmental conditions like high temperature, moisture, dust, vibrations or due to the aging of the components.

When the SSW900 Soft-Starter is stored for a long period of time, it is recommended that it be energized for 1 hour, each year.

Table 5.2: Preventive maintenance

Maintenance	Interval	Instructions
Fan replacement (if used)	After 40.000 hours of operation	Replace the fan
Battery replacement	Every 10 years or when alarm A181 warns that the battery voltage level is low	The battery used is of 3 V, CR2032 type for 85 °C. Recommended brands: Maxell, Panasonic or Roadstar. See Figure 5.2: Procedure to change the battery of the Real Time Clock

Table 5.3: Periodic inspections every six months

Component	Problem	Corrective Action
Terminals, connectors	Loose screws	Tighten
	Loose connectors	
Fans (if used)	Dirt on the fans	Clean
	Abnormal noise	Replace the fan
	Fan stopped	
	Abnormal vibration	
Printed circuit boards	Buildup of dust, oil, moisture, etc.	Clean
	Smell	Replace
Power module / Power connections	Buildup of dust, oil, moisture, etc.	Clean
	Loose connection screws	Tighten
Power resistors	Discoloration	Replace
	Smell	
Heatsinks	Dust buildup	Clean
	Dirt	

5.4.ELECTRONICS FUSE REPLACEMENT

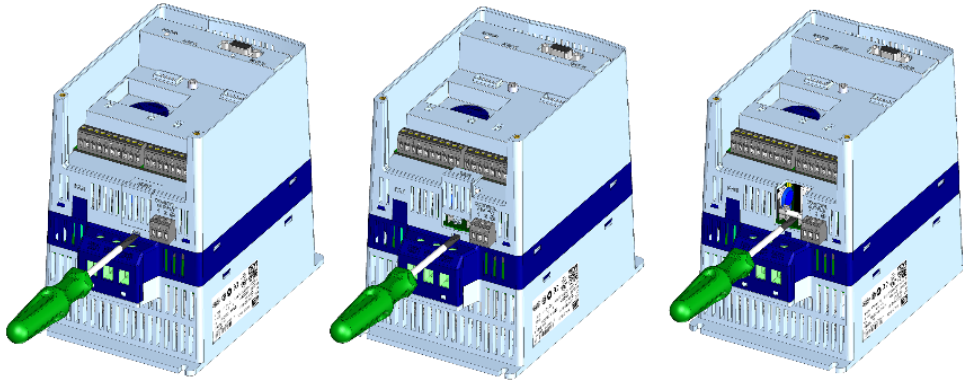

Figure 5.1: Procedure to change the fuse of the electronics power supply

5.5.RTC BATTERY REPLACEMENT

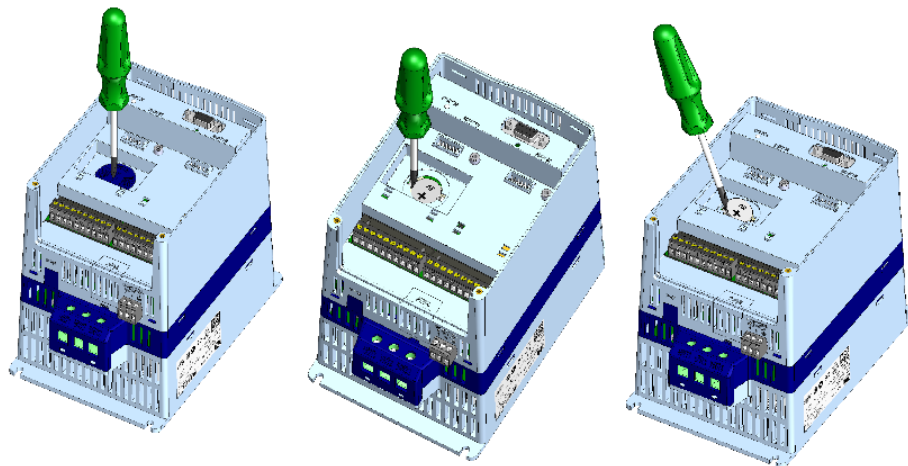

Figure 5.2: Procedure to change the battery of the Real Time Clock

5.6. INFORMATION NECESSARY TO CONTACT TECHNICAL SUPPORT



NOTE!

For technical support or servicing, it is important to have the following information at hand:
 The SSW900 model, serial number and manufacturing date are available on the nameplate of the product (refer to Section 2.3. SOFT-STARTER SSW900).
 Software versions installed (refer to menu S.3.2).
 Data on the motor nameplate (power, voltage, current and number of poles).
 Data on the application and settings made.

For further clarification, training or service, please contact WEG Technical Support.

6 ACCESSORIES

The code and models available of each accessory are presented in the tables below. The accessories may be ordered separately, and they will be shipped in individual packages containing the components and guides with detailed instructions for the installation, operation and programming.

6.1.SLOT 1 AND 2 ACCESSORIES

Table 6.1: Communication accessory

Part number	Name	Description
12966043	SSW900-CRS485-W	Plug-in RS485 communication module – Modbus RTU
14261364	SSW900-CAN-W	Plug-in communication module – CANopen or DeviceNet
14260745	SSW900-CETH-W	Plug-in communication module Ethernet – Modbus TCP and EtherNet/IP
12966003	SSW900-CDN-N	Plug-in Anybus communication module – DeviceNet
12966001	SSW900-CPDP-N	Plug-in Anybus communication module – PROFIBUS DP
12966102	SSW900-CETH-IP-N	Plug-in Anybus communication module – EtherNet/IP
12966038	SSW900-CMB-TCP-N	Plug-in Anybus communication module – Modbus TCP
12966099	SSW900-CPN-IO-N	Plug-in Anybus communication module – PROFINET IO
16708314	SSW900-CPN-S2-N	Plug-in Anybus communication module – PROFINET (S2 functionality)

Table 6.2: Motor temperature measurement accessory

Part number	Name	Description
14260747	SSW900-PT100-W	Plug-in RTD module – 6 channels

Table 6.3: Current measurement accessories for external bypass

Part number	Name	Description
14190553	SSW900-KECA-10	External Current Acquisition – 10 A
14197757	SSW900-KECA-17	External Current Acquisition – 17 A
14197809	SSW900-KECA-24	External Current Acquisition – 24 A
14197811	SSW900-KECA-30	External Current Acquisition – 30 A
14197812	SSW900-KECA-45	External Current Acquisition – 45 A
14197814	SSW900-KECA-61	External Current Acquisition – 61 A
14197815	SSW900-KECA-85	External Current Acquisition – 85 A
14197816	SSW900-KECA-105	External Current Acquisition – 105 A
14197817	SSW900-KECA-130	External Current Acquisition – 130 A
14197838	SSW900-KECA-171	External Current Acquisition – 171 A
14197839	SSW900-KECA-200	External Current Acquisition – 200 A
14197840	SSW900-KECA-255	External Current Acquisition – 255 A
14197841	SSW900-KECA-312	External Current Acquisition – 312 A
14197842	SSW900-KECA-365	External Current Acquisition – 365 A
14197843	SSW900-KECA-412	External Current Acquisition – 412 A



NOTE!

The accessory installed in SLOT 1 must be different from the one installed in SLOT 2. It is not possible to use simultaneously two identical accessories in SLOTS 1 and 2. It is not possible to use two Anybus modules simultaneously, even being two different protocols.

The accessories are easily and quickly incorporated to the SSW900. The models of the accessory installed can be viewed in S3.5.1 and S.3.5.2.

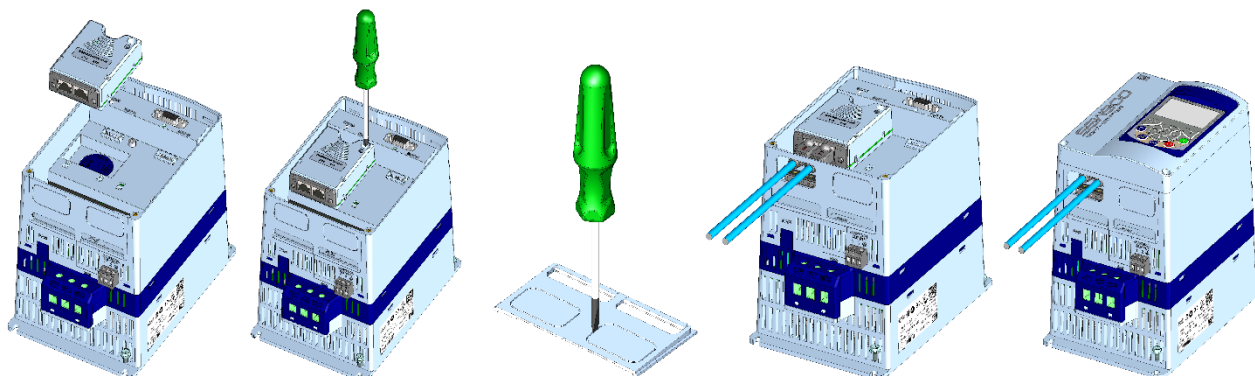

Figure 6.1: Procedure to install accessory



NOTE!

The accessories must be installed with the control of the SSW900 powered down.

6.2.VENTILATION ACCESSORIES

Frames B and C (45 A to 200 A) need a ventilation accessory to allow a greater number of starts per hour. For more details see Chapter 7.

Table 6.4: Ventilation accessory

Part number	Name	Description
10935650	SSW0708900-KVT-2B	Ventilation kit for frame B (Currents 45 to 105 A)
10935559	SSW0708900-KVT-3C	Ventilation kit for frame C (Currents 130 to 200 A)



Figure 6.2: SSW0708900-KVT-2B



Figure 6.3: SSW0708900-KVT-3C

6.3.HMI IN PANEL DOOR ACCESSORIES

SSW900 has a detachable HMI, see Figure 3.15. Therefore, to install the HMI remotely on the door of a panel, a frame accessory with cable can be used.

Table 6.5: HMI frame accessories with cable

Part number	Name	Description
13469204	SSW900-KMD-CB01	Frame Kit for HMI + cable of 1 m
13466665	SSW900-KMD-CB02	Frame Kit for HMI + cable of 2 m
13469206	SSW900-KMD-CB03	Frame Kit for HMI + cable of 3 m
13469207	SSW900-KMD-CB05	Frame Kit for HMI + cable of 5 m
13469208	SSW900-KMD-CB07	Frame Kit for HMI + cable of 7.5 m
13469209	SSW900-KMD-CB10	Frame Kit for HMI + cable of 10 m
13469211	SSW900-KMD-CB20	Frame Kit for HMI + cable of 20 m



Figure 6.4: SSW900-KMD-CBxx

6.4.HMI BLUETOOTH ACCESSORY

SSW900 can be supplied with Bluetooth HMI, see Table 2.1. However, if necessary, it can be purchased separately.

Table 6.6: HMI Bluetooth accessory

Part number	Name	Description
14773867	SSW900-HMI-BLT	Graphical Human Machine Interface with Bluetooth communication



Figure 6.5: SSW900-HMI-BLT

6.5.IP20 ACCESSORIES

IP20 kit, touch protection with the parts energized according to IEC 60529.

Table 6.7: IP20 accessories

Part number	Name	Description
10935651	SSW0708900-IP20-3C	IP20 kit for frame C (Currents 130 to 200 A)
11059230	SSW0708900-IP20-4D	IP20 kit for frame D (Currents 255 to 412 A)

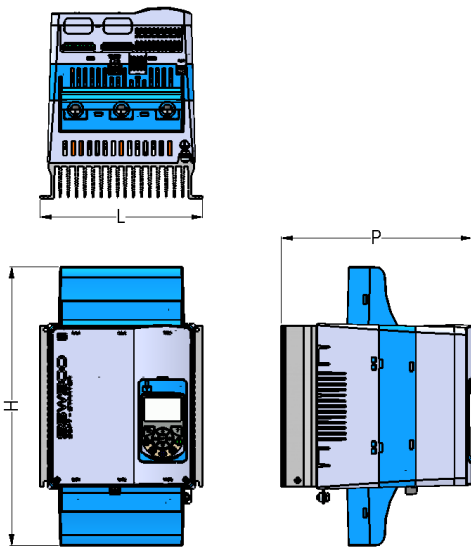

Figure 6.6: SSW0708900-IP20-3C

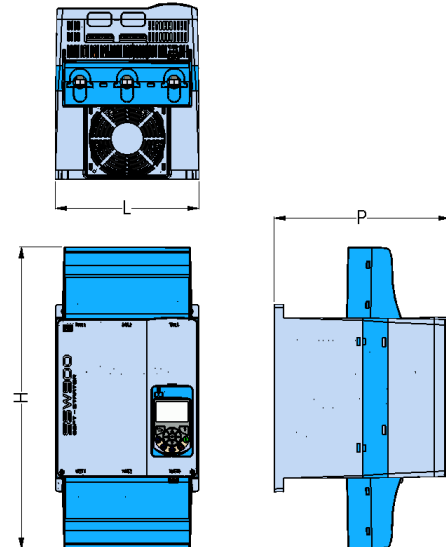

Figure 6.7: SSW0708900-IP20-4D

Table 6.8: Dimensions with IP20 accessories

Model SSW900	Frame	L mm (in)	H mm (in)	P mm (in)
130 A 171 A 200 A	C	233 (9.17)	383 (15.07)	262 (10.31)
255 A 312 A 365 A 412 A	D	230 (9.05)	480 (18.89)	285 (11.22)

6.6.TOUCH PROTECTION ACCESSORIES

Front touch protection with live parts, with more flexibility for power cables.

Table 6.9: Touch protection accessories

Part number	Name	Description
14691775	SSW0708900-PROT-3C	Touch protection kit for frame C (Currents 130 to 200 A)
14691772	SSW0708900-PROT-4D	Touch protection kit for frame D (Currents 255 to 412 A)
14691809	SSW900-PROT-E	Touch protection kit for frame E (Currents 480 to 670 A)

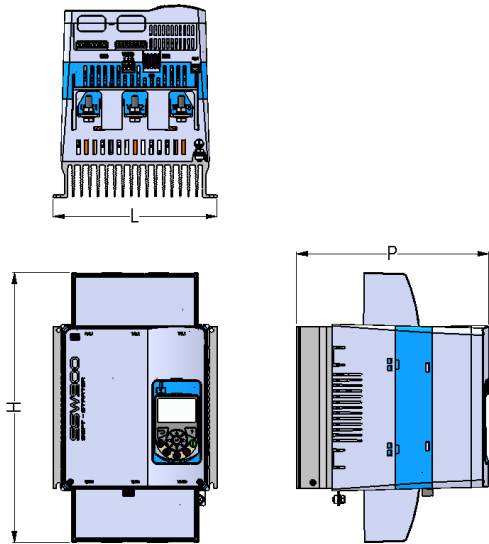

Figure 6.8: SSW0708900-PROT-3C

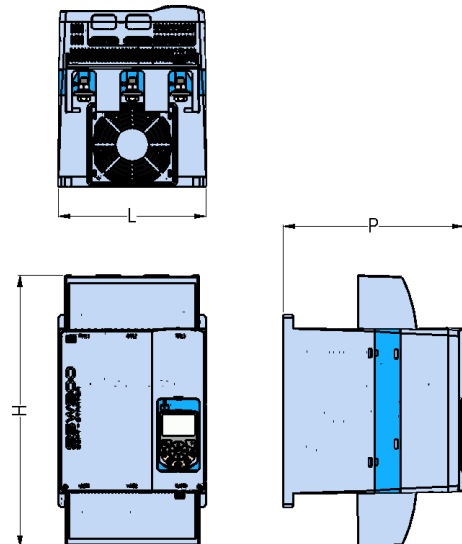

Figure 6.9: SSW0708900-PROT-4D

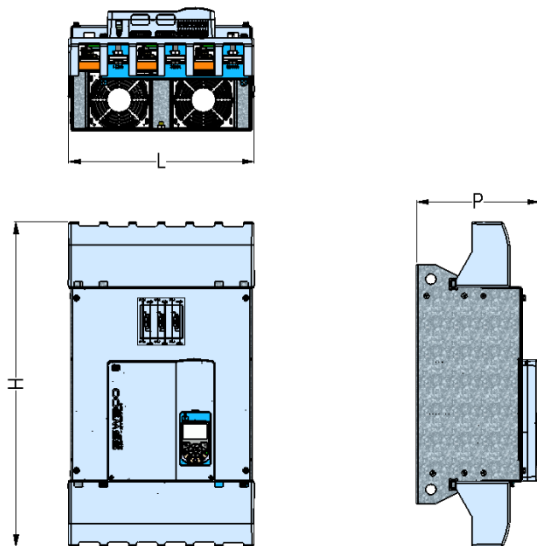

Figure 6.10: SSW900-PROT-E

Table 6.10: Dimensions with touch protection accessories

Model SSW900	Frame	L mm (in)	H mm (in)	P mm (in)
130 A 171 A 200 A	C	223 (8.77)	370 (14.56)	262 (10.31)
255 A 312 A 365 A 412 A	D	230 (9.05)	425 (16.73)	285 (11.22)
480 A 604 A 670 A	E	390 (15.35)	685 (26.96)	260 (10.23)

6.7.POWER BUSBAR ACCESSORIES

SSW900 is supplied with standard power busbar, see Item 3.2.1. However, if necessary, other models are available as accessories to add new busbars or to replace the standard ones.

Table 6.11: Power busbar accessories

Part number	Name	Frame (current)	Description
14691998	SSW900-6BAR-E	E (480 to 670 A)	Kit with 6 busbars to allow the connection of more power cables or external bypass contactor.
16229932	SSW900-3BAR-E-L	E (480 to 670 A)	Kit with 3 busbars to allow connection of terminals with 2 holes.
15144306	SSW900-6BAR-F	F (820 and 950 A)	Kit with 6 busbars to allow the connection of more power cables or external bypass contactor.
16229933	SSW900-3BAR-F-L	F (820 and 950 A)	Kit with 3 busbars to allow the connection of more cables.
16229934	SSW900-3BAR-F-L45S	F (820 and 950 A)	Kit with 3 busbars 45° downwards to allow the connection of more power cables.
16229935	SSW900-3BAR-F-L45L	F (820 and 950 A)	Kit with 3 busbars 45° upwards to allow the connection of more power cables.
15144348	SSW900-3BAR-G	G (1100 and 1400 A)	Kit with 3 busbars 45° downwards to allow the connection of more power cables.

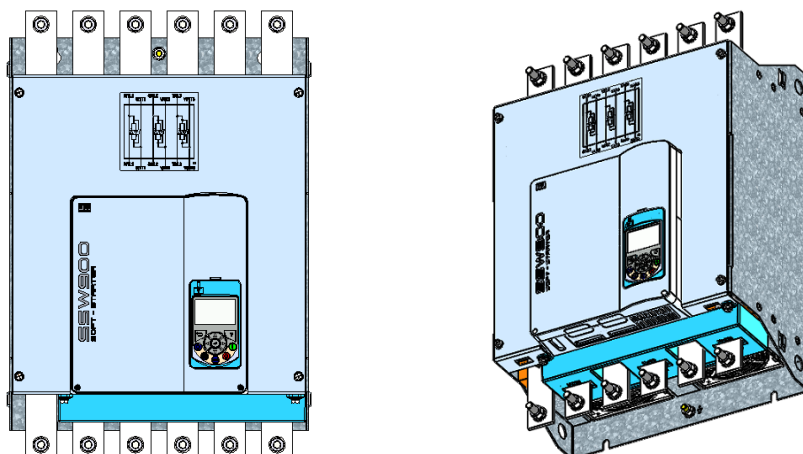

Figure 6.11: SSW900-6BAR-E

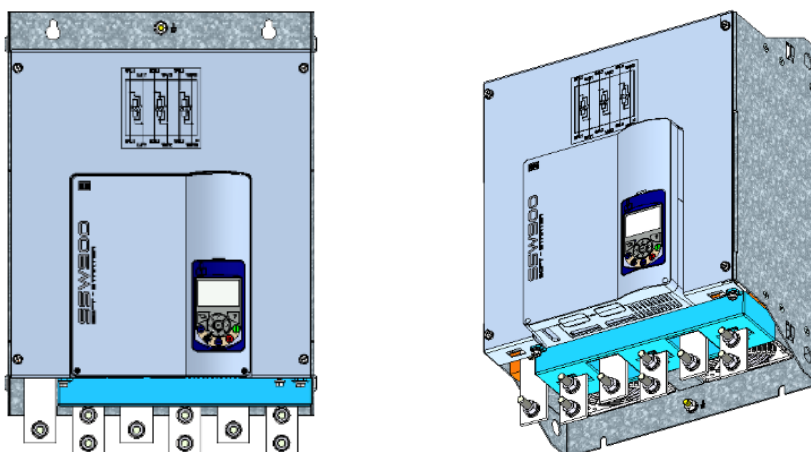

Figure 6.12: SSW900-3BAR-E-L

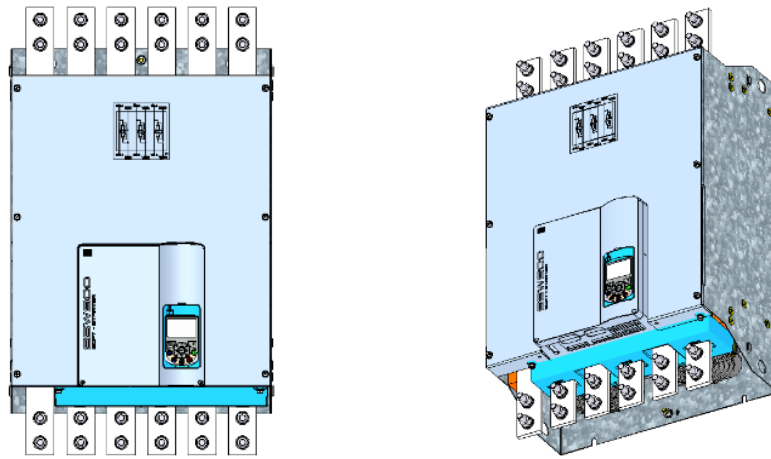

Figure 6.13: SSW900-6BAR-F

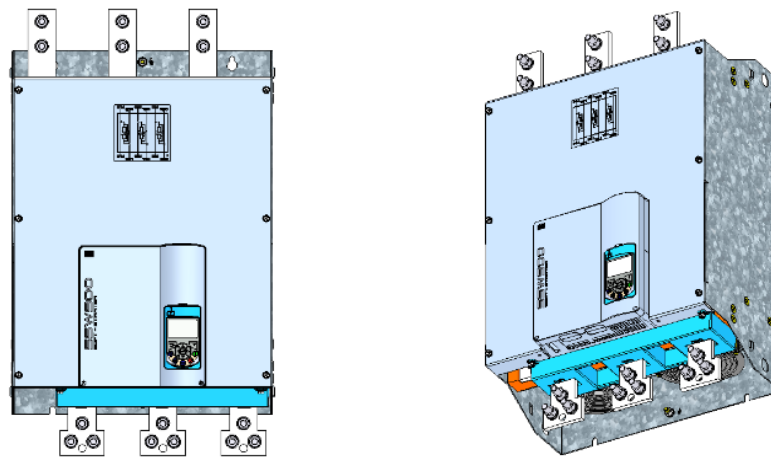

Figure 6.14: SSW900-3BAR-F-L

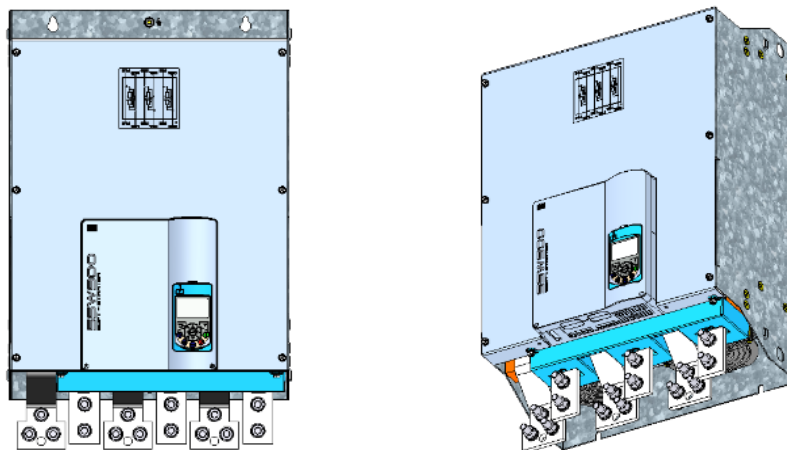

Figure 6.15: SSW900-3BAR-F-L45S

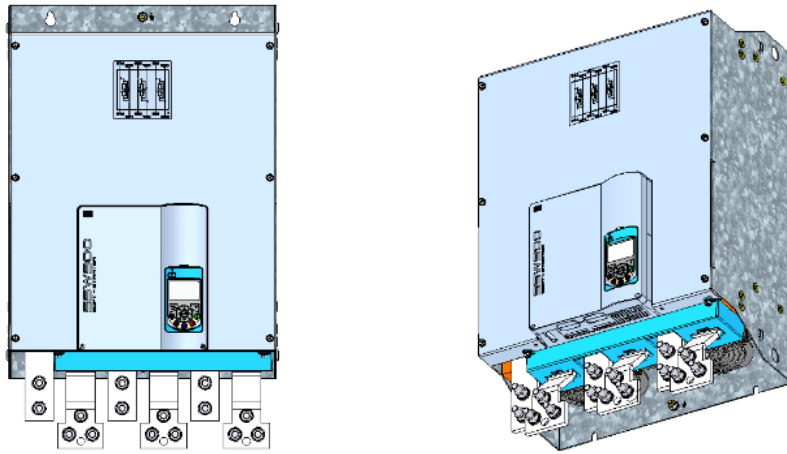

Figure 6.16: SSW900-3BAR-F-L45L

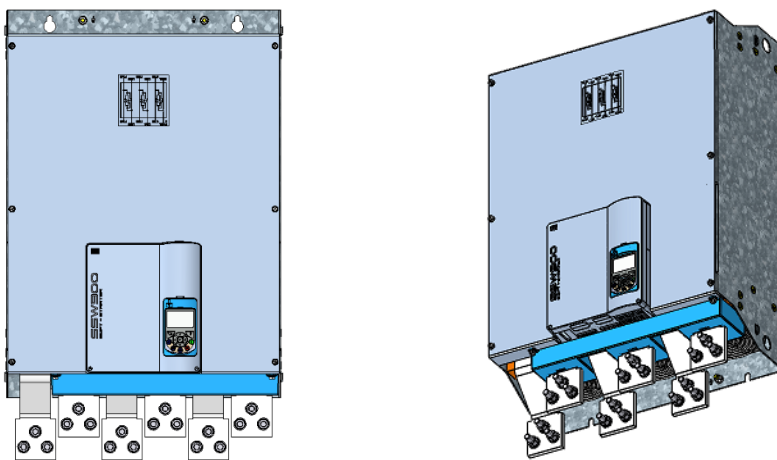

Figure 6.17: SSW900-3BAR-G

7 TECHNICAL CHARACTERISTICS

This chapter describes the technical characteristics of the SSW900.

7.1.POWER DATA

7.1.1.Operation Conditions

According to IEC EN60947-4-2, the operation conditions of the starting devices must be defined. Many manufacturers define them in different ways, not standardized though.

Example 1:

130A: AC-53b:3-30:330

130 A: soft-starter current rating (FLC)

AC-53b: device with integrated bypass

3-: start current (3 x FLC)

30: start time (in seconds)

330: time in nominal conditions (FLC), duty cycle with 100 % of the time ON

30 s + 330 s = 360 s, 360 s x 10 = 1 h, that is, 10 starts per hour

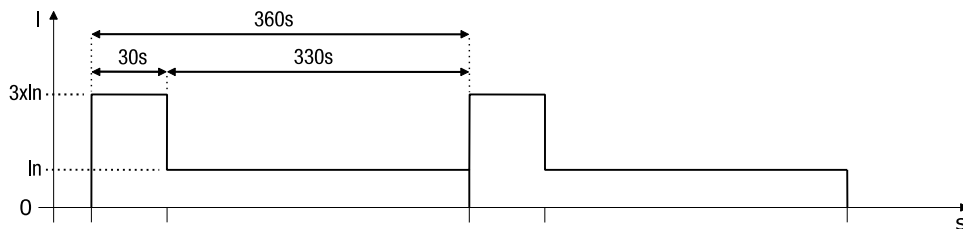

Figure 7.1: AC-53b:3-30:330

Example 2:

130A: AC-53a:4-30:50-6

130 A: soft-starter current rating (FLC)

AC-53a: device without integrated bypass

4-: start current (4 x FLC)

30: start time (in seconds)

50-: duty cycle with 50 % of the time ON (FLC) and 50 % of the time OFF

6: starts per hour

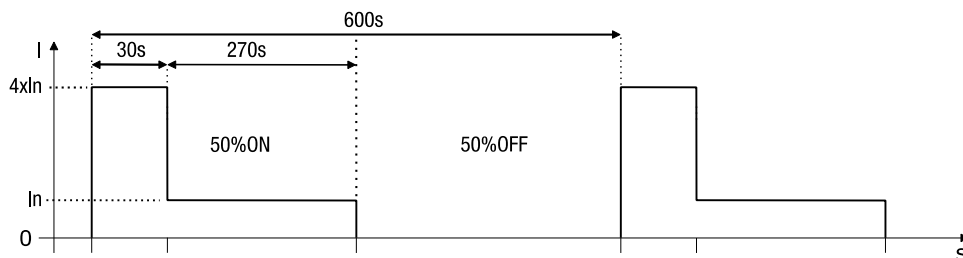

Figure 7.2: AC-53a:4-30:50-6

The SSW900 has the following main definitions:

Table 7.1: Standardized operation conditions

Standard Connection with Three Cables		
Models from 10 A to 30 A and 255 A to 412 A. Models from 45 A to 200 A (with ventilation accessory).	AC-53b 3-30:330	3 x FLC for 30 s 10 starts per hour 100 % of the time with FLC with integrated bypass from -10 to 55 °C (14 °F to 131 °F) without current derating
Models from 45 A to 200 A (without ventilation accessory).	AC-53b 3-30:1170	3 x FLC for 30 s 3 starts per hour 100 % of the time with FLC with integrated bypass from -10 to 55 °C (14 °F to 131 °F) without current derating
Models from 480 A to 1400 A	AC-53b 3-30:690	3 x FLC for 30 s 5 starts per hour 100 % of the time with FLC with integrated bypass from -10 to 40 °C (14 °F to 104 °F) without current derating

Table 7.2: Standardized operation conditions

Inside Delta Motor Connection with Six Cables		
Models from 10 A to 30 A and 255 A to 412 A. Models from 45 A to 200 A (with ventilation accessory).	AC-53b 3-25:335	3 x FLC for 25 s 10 starts per hour 100 % of the time with FLC with integrated bypass from -10 to 55 °C (14 °F to 131 °F) without current derating
Models from 45 A to 200 A (without ventilation accessory).	AC-53b 3-25:1175	3 x FLC for 25 s 3 starts per hour 100 % of the time with FLC with integrated bypass from -10 to 55 °C (14 °F to 131 °F) without current derating
Models from 480 A to 1400 A	AC-53b 3-25:695	3 x FLC for 25 s 5 starts per hour 100 % of the time with FLC with integrated bypass from -10 to 40 °C (14 °F to 104 °F) without current derating

However, the SSW900 can support several working conditions as per below.

7.1.2. Rated Currents According to the Operation Conditions - IEC

Table 7.3: Rated currents according to the operation conditions, standard connection with three cables 55 °C (131 °F)

Model SSW900	AC-53b: 2,5-35:325 A	AC-53b: 3-30:330 A	AC-53b: 3,5-15:345 A	AC-53b: 4-10:350 A	AC-53b: 4-20:340 A	AC-53b: 4,5-30:330 A	10 starts/h
10 A	10	10	10	10	10	10	-
17 A	17	17	17	16	14	11	
24 A	24	24	24	24	21	16	
30 A	30	30	30	30	26	20	
45 A	45	45	41	38	35	30	
61 A	61	61	56	52	48	40	With ventilation accessory
85 A	85	85	80	75	67	56	
105 A	105	105	103	98	85	70	
130 A	130	130	130	126	109	87	
171 A	171	171	171	171	149	114	
200 A	200	200	200	200	172	133	
255 A	255	255	255	255	215	170	
312 A	312	312	312	312	262	208	-
365 A	365	365	365	365	309	243	
412 A	412	412	412	412	351	274	
Model SSW900	AC-53b: 2,5-35:1165 A	AC-53b: 3-30:1170 A	AC-53b: 3,5-15:1185 A	AC-53b: 4-10:1190 A	AC-53b: 4-20:1180 A	AC-53b: 4,5-30:1170 A	3 starts / h
45 A	45	41	38	34	32	28	Without ventilation accessory
61 A	61	61	56	51	48	41	
85 A	85	85	80	74	67	57	
105 A	105	105	104	98	86	70	
130 A	130	130	130	128	110	87	
171 A	171	171	171	171	150	114	
200 A	200	200	200	200	172	133	
Model SSW900	AC-53b: 2,5-35:685 A	AC-53b: 3-30:690 A	AC-53b: 3,5-15:705 A	AC-53b: 4-10:710 A	AC-53b: 4-20:700 A	AC-53b: 4,5-30:690 A	5 starts / h
480 A	480	469	454	423	378	312	-
604 A	604	548	529	492	441	365	
670 A	670	604	590	553	490	402	
820 A	777	672	665	622	551	448	
950 A	942	814	802	748	665	543	
1100 A	935	814	821	769	677	543	
1400 A	1327	1153	1152	1075	952	769	

NOTE!

For Table 7.3 the ambient temperature should not exceed 55 °C (131 °F).
The air temperature below the SSW900 should not be above 55 °C (131 °F).

NOTE!

For use of the SSW900 near maximum duty, set the fan to always on (C9.4.1=1).

Table 7.4: Rated currents according to the operation conditions, inside delta motor connection 55 °C (131 °F)

Model SSW900	AC-53b: 2,5-30:330 A	AC-53b: 3-26:334 A	AC-53b: 3,5-13:347 A	AC-53b: 4-8:352 A	AC-53b: 4-17:343 A	AC-53b: 4,5-26:334 A	10 starts/h
130 A	225	225	225	218	189	151	With ventilation accessory
171 A	296	296	296	296	258	197	
200 A	346	346	346	346	298	230	
255 A	442	441	442	442	372	294	
312 A	540	540	540	540	454	360	
365 A	632	632	632	632	535	421	
412 A	714	713	714	714	609	475	
Model SSW900	AC-53b: 2,5-30:1170 A	AC-53b: 3-26:1174 A	AC-53b: 3,5-13:1187 A	AC-53b: 4-8:1192 A	AC-53b: 4-17:1183 A	AC-53b: 4,5-26:1174 A	3 starts / h
130 A	225	225	225	222	191	151	Without ventilation accessory
171 A	296	296	296	296	260	197	
200 A	346	346	346	346	298	230	
Model SSW900	AC-53b: 2,5-30:690 A	AC-53b: 3-26:694 A	AC-53b: 3,5-13:707 A	AC-53b: 4-8:712 A	AC-53b: 4-17:703 A	AC-53b: 4,5-26:694 A	5 starts / h
480 A	831	812	785	733	655	541	-
604 A	1046	949	916	853	764	633	
670 A	1160	1046	1022	958	848	697	
820 A	1346	1164	1151	1077	954	776	
950 A	1632	1410	1389	1296	1153	940	
1100 A	1620	1411	1422	1332	1172	940	
1400 A	2298	1997	1995	1861	1649	1331	



NOTE!

For Table 7.4 the ambient temperature should not exceed 55 °C (131 °F).
The air temperature below the SSW900 should not be above 55 °C (131 °F).



NOTE!

For use of the SSW900 near maximum duty, set the fan to always on (C9.4.1=1).

Table 7.5: Rated currents according to the operation conditions, standard connection with three cables 40 °C (104 °F)

Model SSW900	AC-53b: 2,5-35:325 A	AC-53b: 3-30:330 A	AC-53b: 3,5-15:345 A	AC-53b: 4-10:350 A	AC-53b: 4-20:340 A	AC-53b: 4,5-30:330 A	10 starts/h
10 A	10	10	10	10	10	10	-
17 A	17	17	17	17	16	13	
24 A	24	24	24	24	23	18	
30 A	30	30	30	30	28	22	
45 A	45	45	45	42	39	34	
61 A	61	61	61	56	52	44	
85 A	85	85	85	81	73	61	With ventilation accessory
105 A	105	105	105	105	94	77	
130 A	130	130	130	130	125	99	
171 A	171	171	171	171	170	130	
200 A	200	200	200	200	193	150	
255 A	255	255	255	255	239	189	
312 A	312	312	312	312	284	225	-
365 A	365	365	365	365	335	264	
412 A	412	412	412	412	379	297	
Model SSW900	AC-53b: 2,5-35:1165 A	AC-53b: 3-30:1170 A	AC-53b: 3,5-15:1185 A	AC-53b: 4-10:1190 A	AC-53b: 4-20:1180 A	AC-53b: 4,5-30:1170 A	3 starts / h
45 A	45	45	43	39	37	32	Without ventilation accessory
61 A	61	61	61	56	53	45	
85 A	85	85	85	81	74	62	
105 A	105	105	105	105	97	79	
130 A	130	130	130	130	125	99	
171 A	171	171	171	171	170	130	
200 A	200	200	200	200	193	150	
Model SSW900	AC-53b: 2,5-35:685 A	AC-53b: 3-30:690 A	AC-53b: 3,5-15:705 A	AC-53b: 4-10:710 A	AC-53b: 4-20:700 A	AC-53b: 4,5-30:690 A	5 starts / h
480 A	480	480	480	470	420	348	-
604 A	604	604	582	541	486	403	
670 A	670	670	653	612	542	446	
820 A	820	820	807	753	670	547	
950 A	950	950	932	868	775	633	
1100 A	1100	1100	1100	1027	909	733	
1400 A	1400	1400	1392	1296	1153	933	

NOTE!

For Table 7.7 the ambient temperature should not exceed 50 °C (122 °F).
The air temperature below the SSW900 should not be above 50 °C (122 °F).

NOTE!

For use of the SSW900 near maximum duty, set the fan to always on (C9.4.1=1).

Table 7.6: Rated currents according to the operation conditions, inside delta motor connection 40 °C (104 °F)

Model SSW900	AC-53b: 2,5-30:330 A	AC-53b: 3-26:334 A	AC-53b: 3,5-13:347 A	AC-53b: 4-8:352 A	AC-53b: 4-17:343 A	AC-53b: 4,5-26:334 A	10 starts/h
130 A	225	225	225	225	217	171	With ventilation accessory
171 A	296	296	296	296	294	225	
200 A	346	346	346	346	334	260	
255 A	442	442	442	442	414	328	
312 A	540	540	540	540	492	390	
365 A	632	632	632	632	579	457	
412 A	714	714	714	714	657	514	
Model SSW900	AC-53b: 2,5-30:1170 A	AC-53b: 3-26:1174 A	AC-53b: 3,5-13:1187 A	AC-53b: 4-8:1192 A	AC-53b: 4-17:1183 A	AC-53b: 4,5-26:1174 A	3 starts / h
130 A	225	225	225	225	217	171	Without ventilation accessory
171 A	296	296	296	296	294	225	
200 A	346	346	346	346	334	260	
Model SSW900	AC-53b: 2,5-30:690 A	AC-53b: 3-26:694 A	AC-53b: 3,5-13:707 A	AC-53b: 4-8:712 A	AC-53b: 4-17:703 A	AC-53b: 4,5-26:694 A	5 starts / h
480 A	831	831	831	814	728	603	-
604 A	1046	1046	1008	937	841	698	
670 A	1160	1160	1131	1059	939	773	
820 A	1420	1420	1398	1304	1161	947	
950 A	1645	1645	1614	1504	1342	1097	
1100 A	1905	1905	1905	1779	1575	1270	
1400 A	2425	2425	2411	2245	1997	1617	



NOTE!

For Table 7.6 the ambient temperature should not exceed 40 °C (104 °F).
The air temperature below the SSW900 should not be above 40 °C (104 °F).



NOTE!

For use of the SSW900 near maximum duty, set the fan to always on (C9.4.1=1).

In order to calculate the maximum rated power of the motors that can be driven by the SSW900, you just have to use the equation:

$$Pn_{Mot} = Vn_{Mot} \times In_{SSW} \times \sqrt{3} \times Re \times \cos \varphi$$

Pn_{Mot} : Motor rated power

Vn_{Mot} : Motor rated voltage

In_{SSW} : Rated current of the SSW (according to the operation conditions)

Re : Motor efficiency

$\cos \varphi$: Motor power factor

7.1.3. Rated Currents According to the Operation Conditions - UL

The following tables show the current values allowed according to the duty cycle: Light, Normal and Heavy.

Table 7.7: Rated currents according to the operation conditions, standard connection with three cables 50 °C (122 °F)

Model SSW900	Light 300%, 10 s, 6 starts/h (A)	Normal 350%, 30 s, 4 starts/h (A)	Heavy 450%, 30 s, 4 starts/h (A)	
10 A	10	10	10	-
17 A	17	17	14	
24 A	24	24	21	
30 A	30	30	26	
45 A	45	42	32	Models of 45A a 200A With ventilation accessory
61 A	61	56	44	
85 A	85	79	61	
105 A	105	100	78	
130 A	130	126	98	
171 A	171	169	131	
200 A	200	200	156	
255 A	255	247	192	-
312 A	312	296	230	
365 A	365	347	270	
412 A	412	393	306	
480 A	480	424	330	
604 A	604	494	384	
670 A	670	546	425	
820 A	820	650	506	
950 A	950	749	582	
1100 A	1100	849	660	
1400 A	1400	1083	843	
Model SSW900	Light 300%, 10 s, 6 starts/h (A)	Normal 350%, 30 s, 4 starts/h (A)	Heavy 450%, 30 s, 4 starts/h (A)	
45 A	45	37	28	Models of 45A a 200A Without ventilation accessory
61 A	61	53	41	
85 A	85	73	57	
105 A	105	90	70	
130 A	130	112	87	
171 A	171	145	113	
200 A	200	169	131	



NOTE!

For Table 7.5 the ambient temperature should not exceed 40 °C (104 °F).
The air temperature below the SSW900 should not be above 40 °C (104 °F).



NOTE!

For use of the SSW900 near maximum duty, set the fan to always on (C9.4.1=1).

7.1.4. Power Tables for Standardized Duty Cycle

The following tables present the power of some standard Nema motors for standardized work regime. However, they can be optimized according to the working regime used and the rated motor data.

The easiest way to choose the SSW900 to be used is by the motor rated current, service factor, operation conditions and by using WEG Sizing Software (SDW).

Table 7.8: Powers and currents for standard connection with three cables according to UL508

Model SSW900	Rated Current	Motor Voltage 220-240 V SSW - T5	Motor Voltage 380-415 V SSW - T5, T6	Motor Voltage 440-480 V SSW - T5, T6	Motor Voltage 550-600 V SSW - T5, T6
	A	HP	HP	HP	HP
10 A	10	3	5	5	7.5
17 A	17	6	7.5	12.5	15
24 A	24	7.5	10	15	20
30 A	30	10	15	20	25
45 A	45	15	25	30	40
61 A	61	20	30	40	50
85 A	85	30	50	60	75
105 A	105	40	60	75	100
130 A	130	50	75	100	125
171 A	171	60	100	125	150
200 A	200	75	100	150	200
255 A	255	100	150	200	250
312 A	312	125	175	250	300
365 A	365	150	200	300	350
412 A	412	150	250	300	450
480 A	480	200	300	400	500
604 A	604	250	350	500	600
670 A	670	250	400	550	700
820 A	820	300	500	650	850
950 A	950	350	600	800	1000
1100 A	1100	450	700	900	1150
1400 A	1400	550	850	1050	1450

Models ≤ 412 A: AC-53b 3-30: 330, ambient temperature 55 °C (131 °F);
 Models ≥ 480 A: AC-53b 3-30: 690, ambient temperature 40 °C (104 °F);
 Models 45 A to 200 A: with ventilation accessory;
 UL standard motors.

Table 7.9: Powers and currents for inside delta motor connection with six cables according to UL508

Model SSW900	Rated Current	Motor Voltage 220-240 V SSW – T5	Motor Voltage 380-415 V SSW – T5, T6	Motor Voltage 440-480 V SSW – T5, T6	Motor Voltage 550-600 V SSW – T6
	A	HP	HP	HP	HP
130 A	225	75	125	175	200
171 A	296	100	150	200	250
200 A	346	125	200	250	300
255 A	441	175	250	300	450
312 A	540	200	300	450	550
365 A	631	250	400	500	650
412 A	713	250	400	600	800

Models ≤ 412 A: AC-53b 3-25: 335, ambient temperature 55 °C (131 °F);
 Models 130A to 200A: with ventilation accessory;
 UL standard motors.

Table 7.10: Powers and currents for standard connection with three cables according to WEG motors

Model SSW 900	Rated Current	Motor Voltage 220/230 V SSW – T5		Motor Voltage 380/400 V SSW – T5, T6		Motor Voltage 440/460 V SSW – T5, T6		Motor Voltage 525 V SSW – T5, T6		Motor Voltage 575 V SSW – T5, T6		Motor Voltage 690 V SSW – T6	
		A	cv	kW	cv	kW	cv	kW	cv	kW	cv	kW	cv
10 A	10	3	2.2	6	4.5	7.5	5.5	7.5	5.5	10	7.5	-	-
17 A	17	6	4.5	10	7.5	12.5	9.2	15	11	15	11	-	-
24 A	24	7.5	5.5	15	11	15	11	20	15	20	15	-	-
30 A	30	10	7.5	20	15	20	15	25	18.5	30	22	-	-
45 A	45	15	11	30	22	30	22	40	30	40	30	-	-
61 A	61	20	15	40	30	50	37	50	37	60	45	-	-
85 A	85	30	22	60	45	60	45	75	55	75	55	-	-
105 A	105	40	30	75	55	75	55	75	55	100	75	-	-
130 A	130	50	37	75	55	100	75	125	90	125	90	150	110
171 A	171	60	45	125	90	125	90	150	110	175	132	220	165
200 A	200	75	55	150	110	150	110	200	150	200	150	250	185
255 A	255	100	75	175	132	200	150	250	185	250	185	340	250
312 A	312	125	90	200	150	250	185	300	220	300	220	430	320
365 A	365	150	110	250	185	300	225	350	260	400	300	470	350
412 A	412	150	110	300	220	350	260	440	315	450	330	500	370
480 A	480	200	150	350	260	400	300	500	370	500	370	600	450
604 A	604	250	185	450	330	500	370	600	450	650	485	750	550
670 A	670	250	185	500	370	550	410	650	485	750	550	850	630
820 A	820	350	260	550	410	700	525	800	600	850	630	1000	750
950 A	950	400	300	750	550	800	600	900	670	1050	775	1150	860
1100 A	1100	450	330	800	600	900	670	1100	810	1200	900	1300	1000
1400 A	1400	550	410	1000	750	1200	900	1400	1050	1500	1100	1700	1250

Models ≤ 412 A: AC-53b 3-30: 330, ambient temperature 55 °C (131 °F);

Models ≥ 480 A: AC-53b 3-30: 690, ambient temperature 40 °C (104 °F);

Models 45 A to 200 A: with ventilation accessory;

Weg Premium Motors or Plus IV Poles

Table 7.11: Powers and currents for inside delta motor connection with six cables according to WEG motors

Model SSW900	Rated Current	Motor Voltage 220/230 V SSW – T5		Motor Voltage 380/400 V SSW – T5, T6		Motor Voltage 440/460 V SSW – T5, T6		Motor Voltage 525 V SSW – T6		Motor Voltage 575 V SSW – T6	
		A	cv	kW	cv	kW	cv	kW	cv	kW	cv
130 A	225	75	55	150	110	175	132	200	150	250	185
171 A	296	125	90	200	150	200	150	250	185	300	220
200 A	346	150	110	250	185	300	220	300	220	350	260
255 A	441	175	132	300	220	350	260	400	300	450	330
312 A	540	200	150	350	260	450	330	500	370	550	410
365 A	631	250	185	450	330	500	370	600	450	650	485
412 A	713	250	185	500	370	600	450	700	525	800	600
480 A	831	350	260	600	450	700	525	800	600	900	670
604 A	1046	450	330	750	550	850	630	1050	775	1150	820
670 A	1160	500	370	850	630	950	700	1150	820	1250	920
820 A	1420	600	450	1000	750	1200	900	1400	1050	1550	1140
950 A	1645	720	520	1200	900	1400	1030	1650	1200	1800	1325
1100 A	1905	800	600	1400	1030	1600	1175	1900	1400	2100	1550
1400 A	2425	1050	775	1750	1290	2000	1475	2450	1800	2650	1950

Models ≤ 412 A: AC-53b 3-25: 335, ambient temperature 55 °C (131 °F);

Models ≥ 480 A: AC-53b 3-25: 695, ambient temperature 40 °C (104 °F);

Models 130A to 200A: with ventilation accessory;

Weg Premium Motors or Plus IV Poles.

7.2. OPERATING RANGE OF POWER

Power supply	Power Voltage (R/1L1, S/3L2, T/5L3)	T5 = 220 to 575 V (-15 % to +10 %), or 187 to 632 Vac (standard connection) T6 = 380 to 690 V (-15 % to +10 %), or 323 to 759 Vac (standard connection) T5 = 220 to 500 V (-15 % to +10 %), or 187 to 550 Vac (inside delta) T6 = 380 to 575 V (-15 % to +10 %), or 323 to 632 Vac (inside delta)
	Frequency	50 to 60 Hz ($\pm 10\%$), or 45 to 66 Hz.
Capacity	Maximum number of starts per hour, starting duty	According to Table 7.1 and Table 7.2.
Thyristor (SCRs)		Maximum reverse peak voltage 1600 V (T5). Maximum reverse peak voltage 1800 V (T6).

7.3. ELECTRONICS DATA

Power supply	Control voltage	Models from 10 A to 200 A: E2 = 110 to 240 V (-15 % to +10 %), or 93.5 to 264 Vac Models from 255 to 1400 A: E3 = 110 to 130 V (-15 % to +10 %), or 93.5 to 143 Vac, or E4 = 220 to 240 V (-15 % to +10 %), or 187 to 264 Vac
	Frequency	50 to 60 Hz ($\pm 10\%$), or 45 to 66 Hz
	Consumption	Models from 10 A to 200 A: 32 VA. Models from 255 to 412 A: 70 VA continuous, 700 VA additional during the closing of the internal bypass. Models from 480 to 670 A: 90 VA continuous, 700 VA additional during the closing of the internal bypass. Models from 820 to 950 A: 140 VA continuous, 800 VA additional during the closing of the internal bypass. Models from 1100 to 1400 A: 180 VA continuous, 850 VA additional during the closing of the internal bypass.
Inputs	Digital	5 isolated digital inputs: Minimum high level: 18 Vdc; Maximum low level: 3 Vdc; Maximum voltage: 30 Vdc; Input current: 11 mA @ 24 Vdc; Programmable functions.
	Inputs for motor thermistors	1 input for thermistor: Actuation: 3.9 k Ω , Release: 1.6 k Ω ; Minimum resistance: 100 Ω ;
Outputs	Digital	3 isolated digital outputs: 2 relays with NO contacts, 240 Vac, 30 Vdc, PF = 0.6, 2A, programmable functions; 1 relay with NO/NC contact, 240 Vac, 30 Vdc, PF = 0.6, 2A, programmable functions.
	Analog	1 not isolated analog output: 0 to 10 V or 0/4 to 20 mA configurable by software.
HMI Human Machine Interface	Standard HMI	12 keys: Run/Stop, Direction of Rotation, Jog, Local/Remote and browsing buttons: Left, Right, Up, Down, Enter, Back and Help; Graphic LCD display; It allows monitoring/changing all the parameters of the SSW; Option of external mounting, panel door; USB for firmware updates or communication with the product. Degree of protection of the HMI - IP65, with the protection of the USB closed.
PC connection for programming	USB connector by means of the HMI	USB standard Rev. 2.0 (basic speed). USB plug type mini B "device" Interconnecting cable: standard host/device shielded USB cable



NOTE!

Refer to the Programming Manual for information on programming data and all the functions of the SSW900.

7.4. CONSIDERED STANDARDS

Safety standards	UL508 - Industrial control equipment. EN60947-4-2 - Low-voltage switchgear and control gear Contactors and Motor-starters. AC semiconductor motor controllers and starters. 2014/35/EU - Low-Voltage Directive.
Electromagnetic compatibility standards	2014/30/EU - EMC Directive. CISPR 11 - Industrial, scientific and medical (ISM) radio-frequency equipment - electromagnetic disturbance characteristics - limits and methods of measurement EN 61000-4-2 - Electromagnetic compatibility (EMC) - part 4: testing and measurement techniques - section 2: Electrostatic discharge immunity test EN 61000-4-3 - Electromagnetic compatibility (EMC) - part 4: testing and measurement techniques - section 3: radiated, radio-frequency, electromagnetic field immunity test. EN 61000-4-4 - Electromagnetic compatibility (EMC) - part 4: testing and measurement techniques - section 4: electrical fast transient/burst immunity test. EN 61000-4-5 - Electromagnetic compatibility (EMC) - part 4: testing and measurement techniques - section 5: surge immunity test. EN 61000-4-6 - Electromagnetic compatibility (EMC) - part 4: testing and measurement techniques - section 6: immunity to conducted disturbances, induced by radio-frequency fields. EN 61000-4-11 - Electromagnetic compatibility (EMC) - part 4: testing and measurement techniques - section 11: voltage dips, short interruptions and voltage variations immunity tests.
Mechanical construction standards	EN 60529 - degrees of protection provided by enclosures (IP code). UL 50 - enclosures for electrical equipment. IEC 60721-3-3 - classification of environmental conditions.
RoHS	2011/65/EU, 2015/863/EU - RoHS Directive. EN IEC 63000:2018 - Technical documentation for the assessment of electrical and electronic products with respect to the restriction of hazardous substances.

7.5. GROUND INSULATION

The SSW900 has resistive decades for measuring the voltages of the input and output phases of the power and also the electronics supply voltage.

These resistive decades are referenced to the 0V (GND) of electronics. This being 0V (GND) grounded for safety.

Power Phase - Earth	T5 = (220 to 575 V) 1.5 MΩ T6 = (380 to 690 V) 1.875 MΩ
Electronics	Phase - Earth = 1.5 MΩ Neutral - Earth = 1.5 MΩ

8 ATTACHMENT

8.1.CHANGING THE BUSBARS OF THE FRAME E, F, G

The frames E, F and G make it possible to change the position of the busbars.



NOTE!

The change of position of the busbars must only be done by specialized service providers.

The standard product comes with:

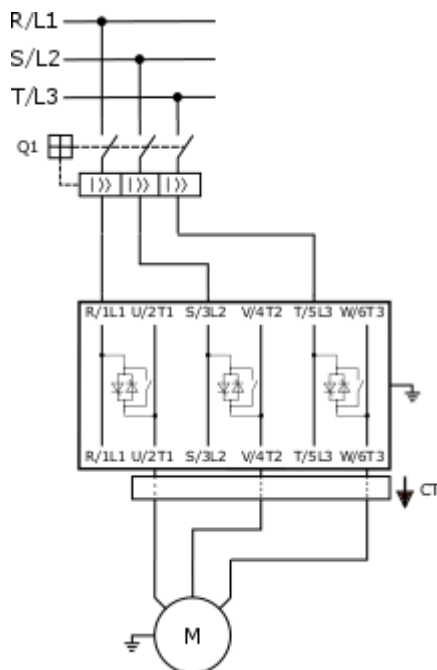

Power supply connection:

R / 1L1, S / 3L2 and T / 5L3

At the top of the SSW and left side of the thyristor bridges.

Motor connection:

U / 2T1, V / 4T2 and W / 6T3

At the bottom of the SSW and right side of the thyristor bridges.



NOTE!

Pay attention to the maximum torque allowed on the busbar mounting screws.

Screw M8 (5/16 ").

Maximum torque 12 Nm (106 lbf·in).



NOTE!

Current transformers "CT" must always remain on the busbars that connect to the motor.



NOTE!

For the use of external bypass, 12 cables, it is necessary to use an accessory with 6 additional busbars, see Table 6.1.

Connection possibilities are shown below:

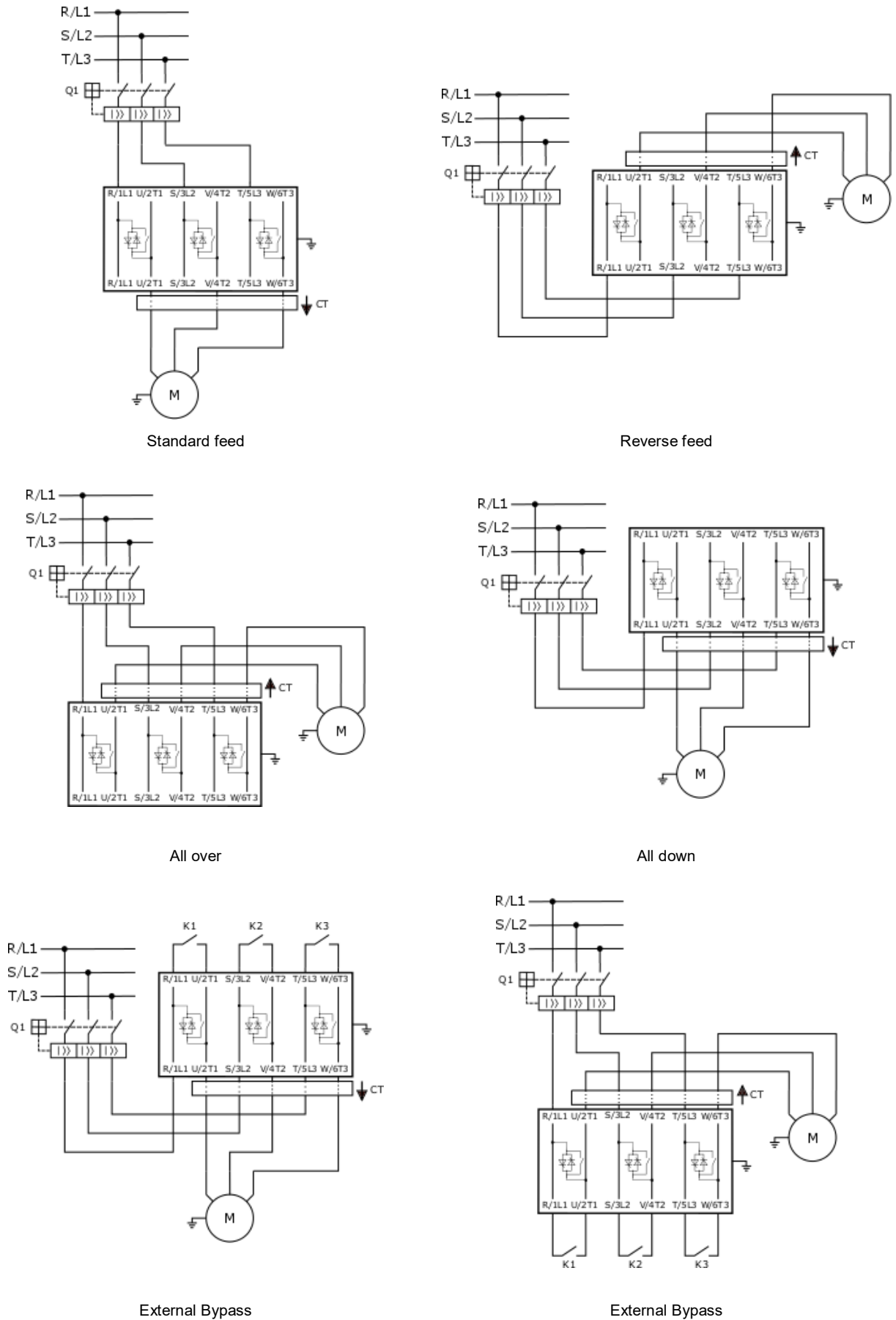
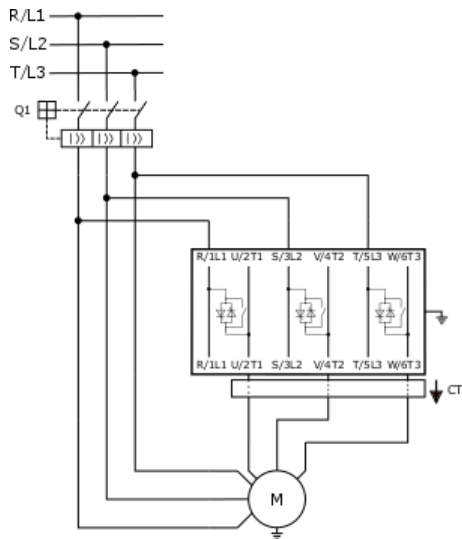
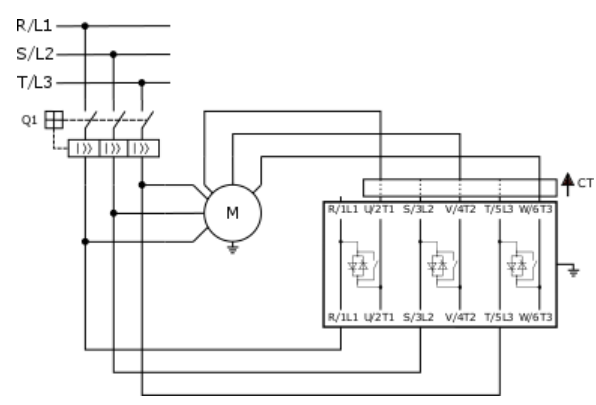

Figure 8.1: Frame E standard connection to the motor with three wires



Standard feed



Reverse feed

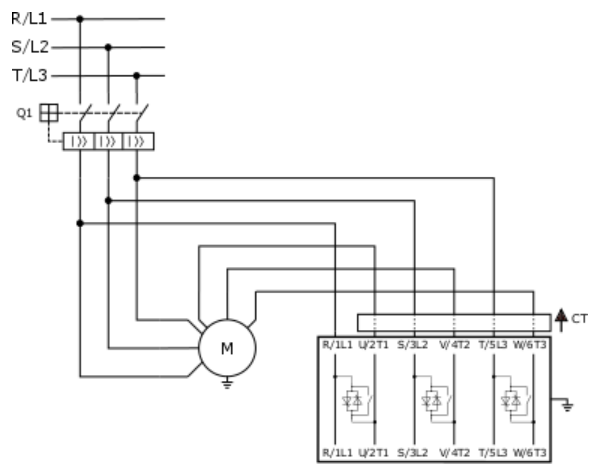

All over

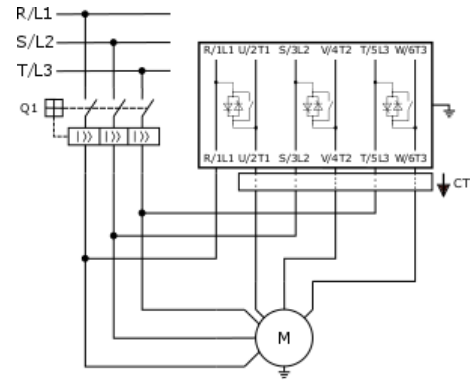

All down

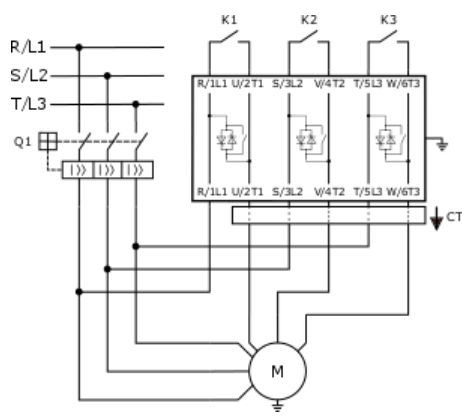

External Bypass

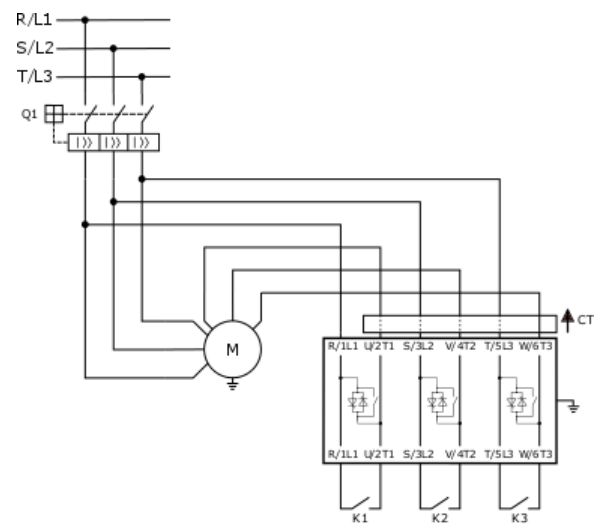

External Bypass

Figure 8.2: Frame E connection inside delta motor with six wires

Process of changing the busbars:

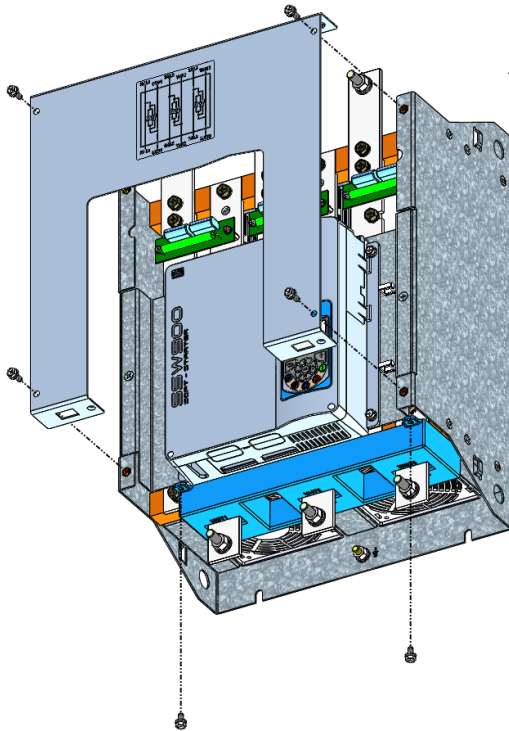

Figure 8.3: Opening the front cover

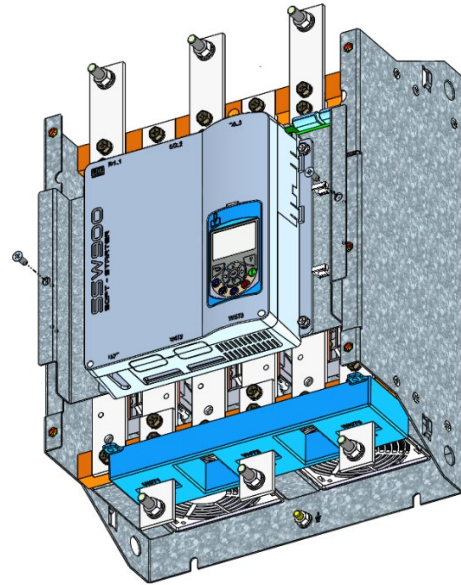

Figure 8.4: Moving the control

There is no need to remove control, just move the necessary to access the busbar screws.

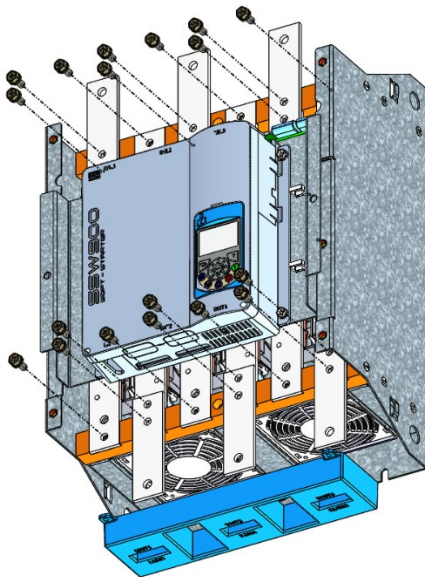

Figure 8.5: Removing the busbars and CT

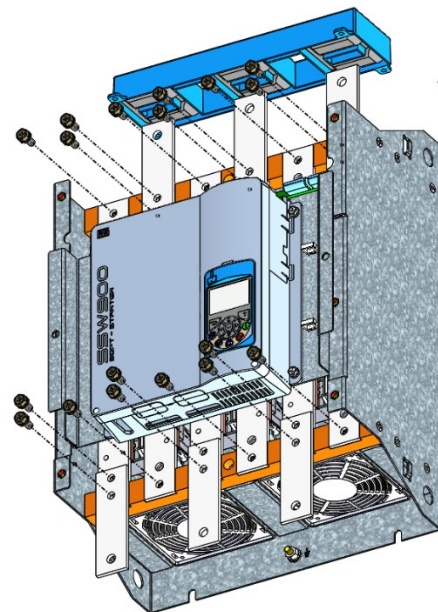

Figure 8.6: Moving the control



NOTE!

Pay attention to the maximum torque allowed on the busbar mounting screws.
Screw M8 (5/16 ").
Maximum torque 12 Nm (106 lbf-in).



NOTE!

Current transformers "CT" must always remain on the busbars that connect to the motor. Pay attention to the U/2T1, V/4T2 and W/6T3 markings.

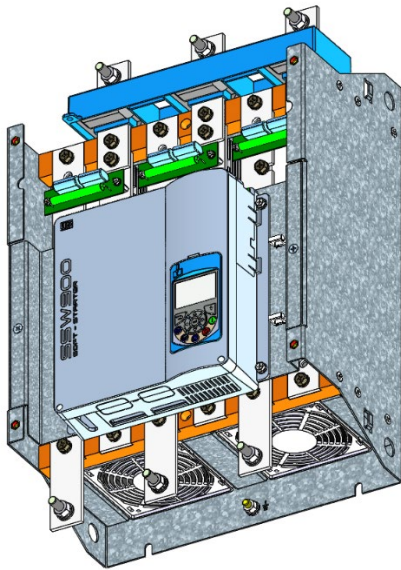

Figure 8.7: Placing control

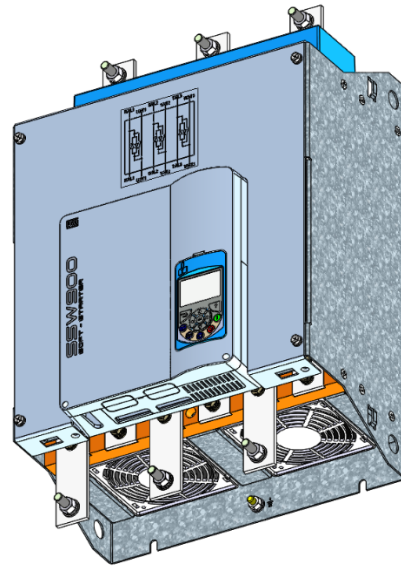

Figure 8.8: Closing the front cover

8.2.USING EXTERNAL CONTACTOR IN FRAMES E, F, G

Here is shown a suggestion for connecting the external contactor using the SSW900 CT set.

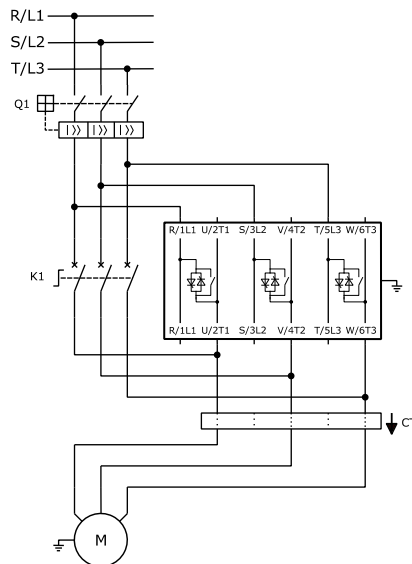

Figure 8.9 External Contactor Connection Scheme

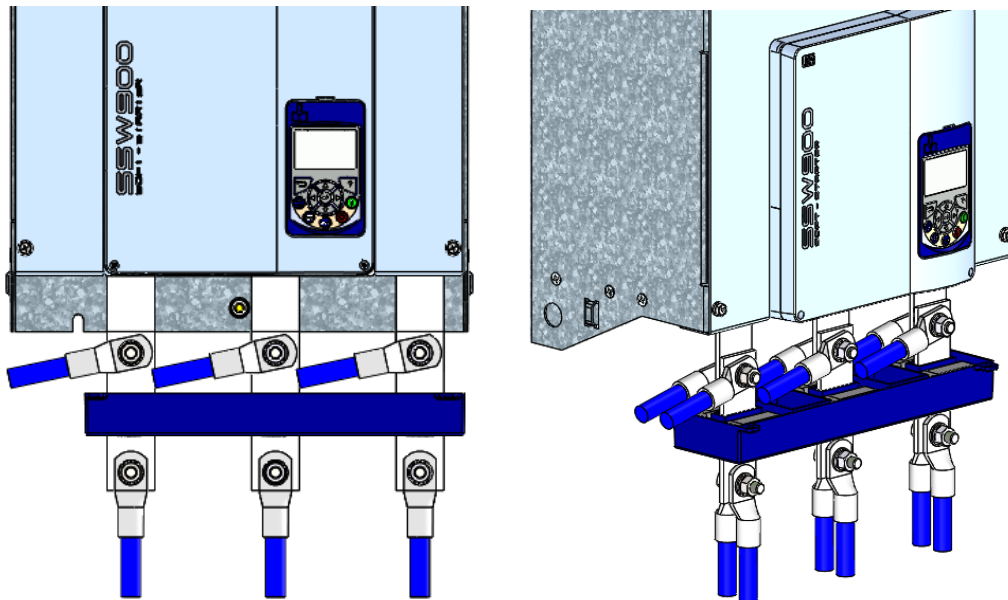

Figure 8.10: Cable Output Suggestion

NOTE!

The CT Set of mechanics E, F and G of the SSW900 are designed to make it possible to change the busbars, above and below the SSW. Therefore, they are small and only allow the passage of copper busbars.

8.3.USING BUSBAR ACCESSORIES FOR USA MARKET

Here is shown a suggestion for connecting and use of the busbar KITs with specifics USA market LUGs.

Table 8.1: Power busbar accessories - SSW900-6BAR-E

Part number	Name	Frame (current)	Description
14691998	SSW900-6BAR-E	E (480 to 670 A)	Kit with six busbars for external bypass connection using only compression lugs. e.g. LCAX450-12-6 (lugs not included in the kit).

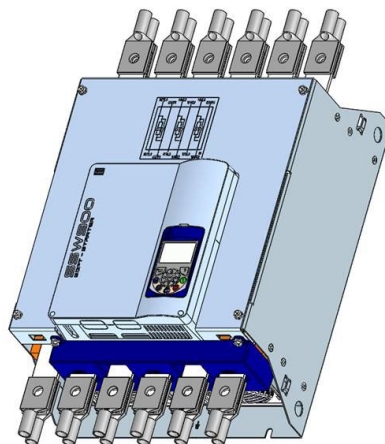

Figure 8.11: 1 x SSW900-6BAR-E

Table 8.2: Power busbar accessories - SSW900-3BAR-E-L

Part number	Name	Frame (current)	Description
16229932	SSW900-3BAR-E-L	E (480 to 670 A)	Kit with three busbars needed to connect all the cables on one side of the SSW900 using mechanical lugs. e.g. PB2-600 (lugs not included in the kit).

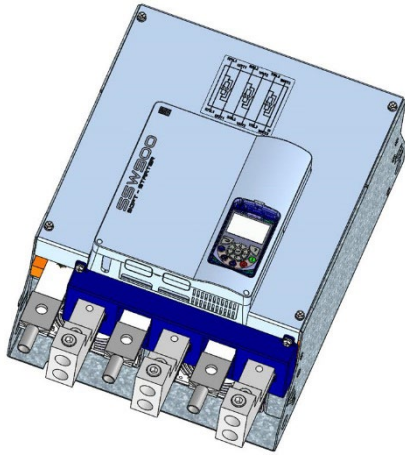

Figure 8.12: 1 x SSW900-3BAR-E-L

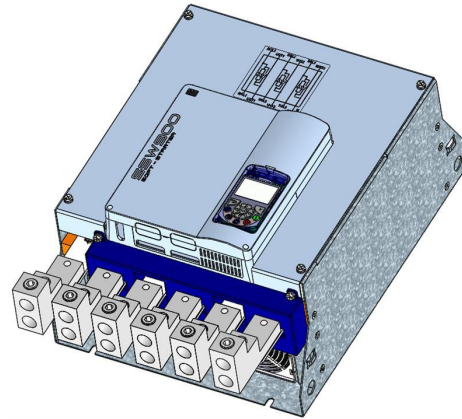

Figure 8.13: 2 x SSW900-3BAR-E-L

Table 8.3: Power busbar accessories - SSW900-6BAR-F

Part number	Name	Frame (current)	Description
15144306	SSW900-6BAR-F	F (820 and 950 A)	Kit with six busbars for external bypass connection using only compression lugs. e.g. LCAX650-58-6, LCAX650-12-6, LCAX750-58-6 or LCAX750-12-3 (lugs not included in the kit).

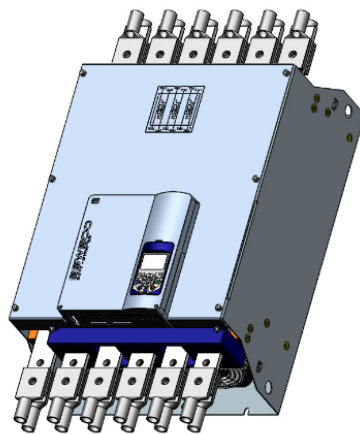

Figure 8.14: 1 x SSW900-6BAR-F

Table 8.4: Power busbar accessories - SSW900-3BAR-F-L

Part number	Name	Frame (current)	Description
16229933	SSW900-3BAR-F-L	F (820 and 950 A)	Kit with three straight busbars to connect three or four cables per phase using compression lugs. e.g. 3 x LCAN400-12-6 or 4 x LCAX250-58-X (lugs not included in the kit).

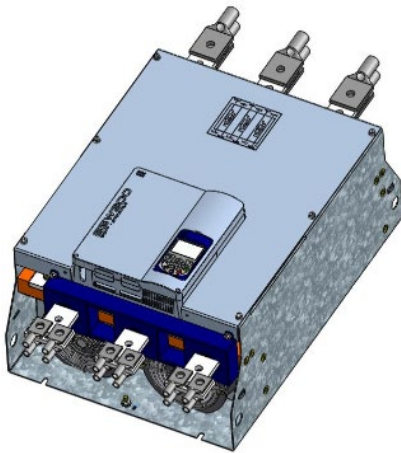

Figure 8.15: 1 x SSW900-3BAR-F-L

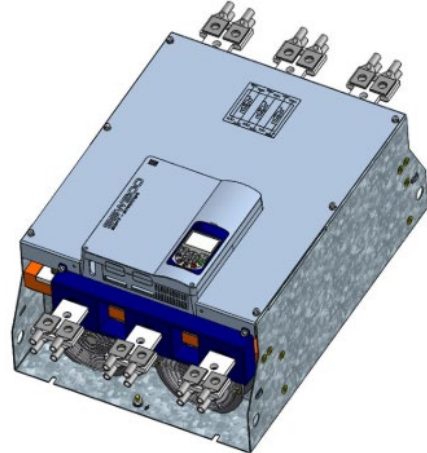

Figure 8.16: 2 x SSW900-3BAR-F-L

Table 8.5: Power busbar accessories - SSW900-3BAR-F-L45S

Part number	Name	Frame (current)	Description
16229934	SSW900-3BAR-F-L45S	F (820 and 950 A)	Kit with three 45° angled, going downwards, busbars for all top or all bottom cable connections. e.g. compression lug 3 x LCAN400-12-6 or 4 x LCAX250-58-X, or mechanical lug PB4-600-2N (lugs not included in the kit).

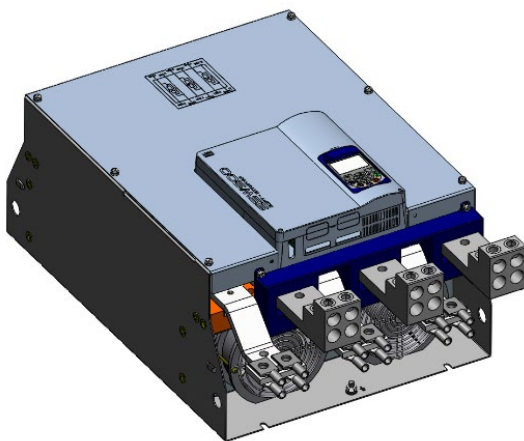

Figure 8.17: 1 x SSW900-3BAR-F-L45S

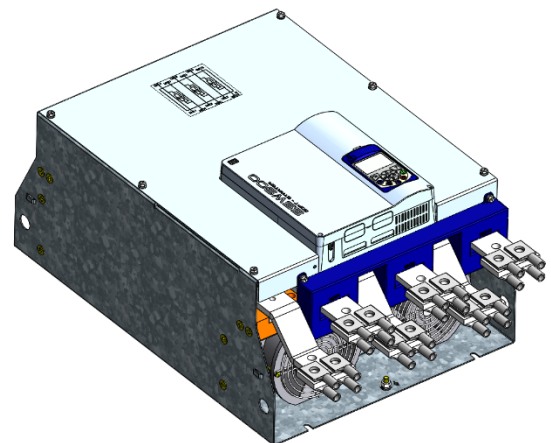

Figure 8.18: 1 x SSW900-3BAR-F-L45S and 1 x SSW900-3BAR-F-L

Table 8.6: Power busbar accessories - SSW900-3BAR-F-L45L

Part number	Name	Frame (current)	Description
16229935	SSW900-3BAR-F-L45L	F (820 and 950 A)	Kit with three 45° angled, going upwards, busbars for all top or all bottom cable connections. e.g. PB4-600-2N (lugs not included in the kit).

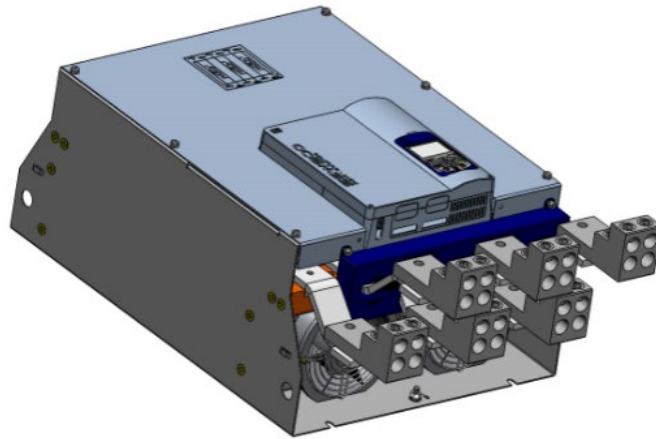

Figure 8.19: 1 x SSW900-3BAR-F-L45L and 1 x SSW900-3BAR-F-L45S

Table 8.7: Power busbar accessories - SSW900-3BAR-G

Part number	Name	Frame (current)	Description
15144348	SSW900-3BAR-G	G (1100 and 1400 A)	Kit with three 45° angled, going downwards, for all top or all bottom cable connections. e.g. compression lug 3 x LKAN750-12-6 or 4 x LKAN500-12-6 or mechanical lug PBMW-4-750-12 (lugs not included in the kit).

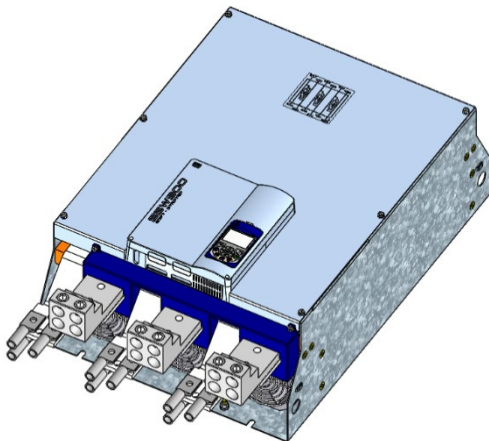

Figure 8.20: 1 x SSW900-3BAR-G with compression lug

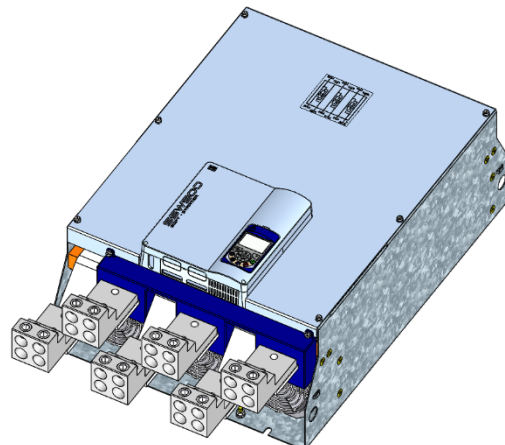

Figure 8.21: 1 x SSW900-3BAR-G with mechanical lug