

ELECTRICAL INSTALLATION



Contents of this Chapter...

2.1 – Warnings & Agency Approvals	2-2
2.1.1 – Isolation	2-2
2.1.2 – Electrical Power and Control Supply Requirements	2-2
2.1.3 – Access	2-2
2.1.4 – Fuse Protection	2-2
2.1.5 – Agency Approvals	2-2
2.2 – Electrical Connections - Specifications	2-3
2.2.1 – Electrical Supplies	2-3
2.2.2 – Control, Power, and Ground Terminations	2-3
2.3 – Standard Wiring Configurations	2-4
2.3.1 – Wiring Diagram for In-Line Connection of Motors	2-4
2.3.2 – Wiring Diagram for In-Delta Connection of Motors	2-5
2.4 – Motor Control Circuits	2-6
2.4.1 – Bypass Control	2-6
2.4.2 – Multiple Motor Starting & Stopping	2-7
2.4.3 – External Motor Protection Relay	2-7
2.4.4 – Motor Reversing	2-7
2.4.6 – Wiring Diagram for Motor Reversing	2-8
2.5 – Electrical Connections - Terminal Locations	2-9
2.5.1 – General Electrical Connections	2-9
2.5.2 – Electronic Control Card	2-11

(Table of Contents continued next page)

ELECTRICAL INSTALLATION



(Table of Contents continued from previous page)

2.6 – Power Supply Connections	2-12
2.6.1 – Power Circuit Electrical Supply	2-12
2.6.2 – Motor Connections	2-12
2.6.3 – Control Circuit Electrical Supply	2-12
2.7 – Control Card Connections	2-13
2.7.1 – Control Inputs	2-13
2.7.2 – Control Outputs	2-13
2.8 – (Reserved for Future Use)	2-13
2.9 – Typical Motor Power at Rated Voltage	2-14
2.9.1 – Chassis Size 1 Motor Power Ratings	2-14
2.9.2 – Chassis Size 2 Motor Power Ratings	2-14
2.10 – Fuse and Current Ratings	2-15
2.10.1 – Full-Load Current Limit and Short-Circuit Protection	2-15
2.10.2 – External Fuse Requirements	2-16
2.10.3 – Overload Current Profile and Duty Cycle AC-53a	2-17
2.10.4 – Overload Current Profile AC-53b	2-18
2.10.5 – Overcurrent Trip Graph	2-19

**ELECTRICAL
INSTALLATION**



**BLANK
PAGE**

2.1 – Warnings & Agency Approvals

2.1.1 – Isolation



Caution: The SR44 uses semiconductor devices in the main circuit, and is not designed to provide isolation. For this reason isolation means must be installed in the power supply circuit in accordance with the appropriate wiring and safety regulations.

2.1.2 – Electrical Power and Control Supply Requirements



All electrical connections are made to power input and output terminals, control terminals, and a ground stud. Before you apply control voltage to the control supply terminals, ensure that the control voltage selector switch is set to the correct voltage being used. (The diagrams in section 2.5 show the location of this selector switch.) Make electrical connections only to those terminals specified. If you connect to other terminals, then you may cause damage to the SR44 internal control circuitry.



Do NOT install power factor correction capacitors on the output side of the SR44.

2.1.3 – Access



Caution: Always replace the cover on the Soft Starter after gaining access to the electrical connections.

2.1.4 – Fuse Protection



The Main Supply and the Control Supply each require protection. Although all units have electronic overload protection for the Soft Starter, the installer should always install fuses for motor protection between the Soft Starter and the Main Supply; NOT between the Soft Starter and the motor.



Semiconductor fuses can be supplied as an option for short-circuit protection of the semiconductors. These fuses must be installed externally to the SR44 chassis to comply with UL standards. Chassis size 2 has the capability of installing fuses internally by replacing the fuse links in the power circuit. It is the responsibility of the installer and system designer/specifier to ensure that the required standards or regulations are not affected by so doing.

2.1.5 – Agency Approvals

- CE
- RoHS
- UL – E333109

2.2 – Electrical Connections - Specifications

2.2.1 – Electrical Supplies

The SR44 requires two AC electrical power sources:

- 1) A balanced 3-phase main source to provide the power for the controlled motor.
- 2) A single-phase supply: 115V or 230V, 50Hz/60Hz, for the internal control circuitry.



The unit will not operate unless the control supply voltage is within the specified limits. We recommend that the control supply be maintained between starts to ensure overload integrity, since the overload will reset on control supply removal.

2.2.2 – Control, Power, and Ground Terminations

Control Terminal Specifications

SR44 Control Terminal Specifications							
Terminals	Terminal Type	Wire Type	Cable Cross Section				Tightening Torque
			AWG		mm ²		
			Min	Max	Min	Max	
X1, X2 S0, S1 11, 12, 14 21, 22, 24	screw clamp terminals with captive screws	solid or stranded	22	14	0.3	2.5	4.4 lb·in [0.5 N·m]

Power and Ground Terminal Specifications

SR44 Power and Ground Terminal Specifications								
Soft Starter Model	Terminals		Terminal Type	Conductor Type	Cable Cross Section *		Bus-bar *	Tightening Torque
					AWG	mm ²		
Size 1: SR44-9 to SR44-146	Power	L1, L2, L3 T1, T2, T3	M8 metric threaded studs	Use 75 °C copper (CU) conductor only, and the wire shall be installed with eyelet lug	1/0	50	n/a	106 lb·in [12 N·m]
	Ground	PE						
Size 2: SR44-174 to SR44-370	Power	L1, L2, L3 T1, T2, T3	M8 metric threaded studs	Use 75 °C copper (CU) conductor only, and the wire shall be installed with eyelet lug, or use busbar	2 x 250 MCM	2 x 120	20 x 6	106 lb·in [12 N·m]
	Ground	PE						

* *The indicated conductor sizes are the maximum allowed by UL for each chassis size. The actual conductors used must comply with local wiring regulations*

2.3 – Standard Wiring Configurations

There are two standard wiring configurations for the connection of a motor, a motor controller (Soft Starter), and the main power supply:

- In-line connection for Delta and Star (Wye) connected motors.
This is the recommended connection that is suitable for most motors.
- In-delta connection for Delta connected motors.
If required, the SR44 can be electrically installed within the delta windings.

2.3.1 – Wiring Diagram for In-Line Connection of Motors

Figure 2.3.1: Wiring Diagram for In-Line Connection of Motors

(Two legs of a 230V 3-phase power source can be used to provide 230V 1-phase control power.)

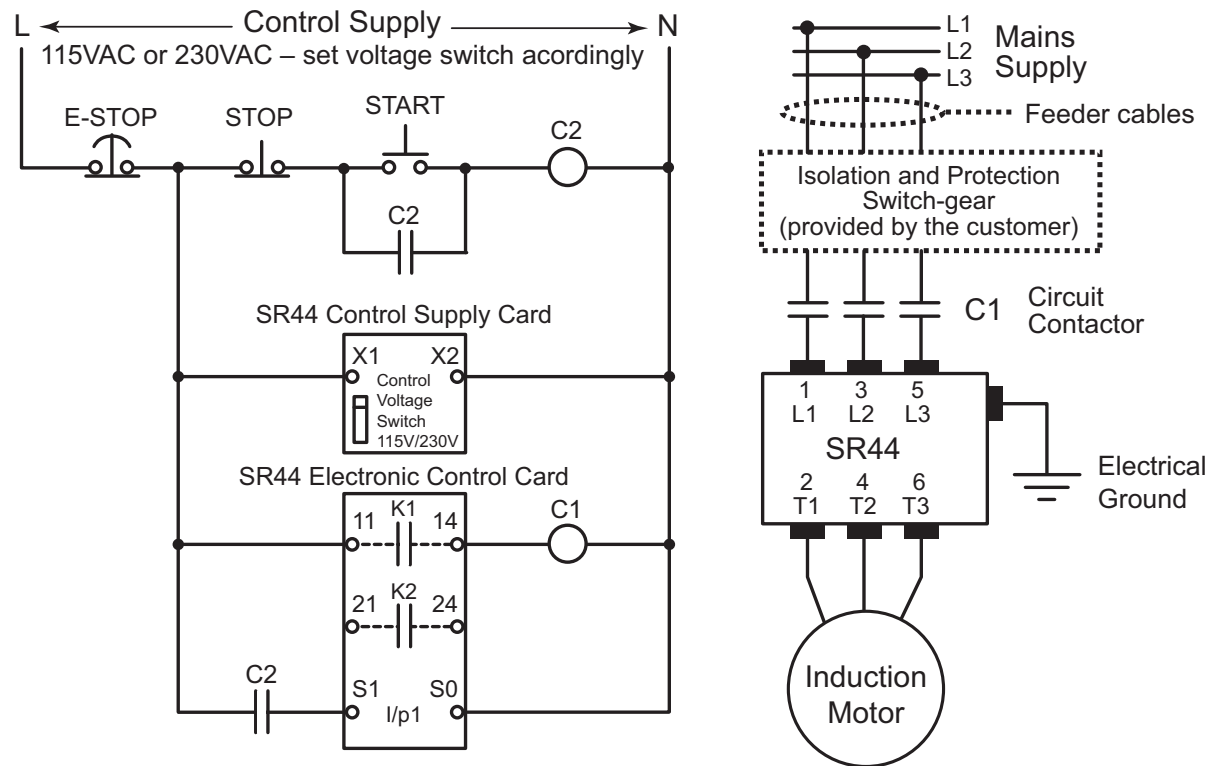

Important:

Be sure to set the Control Voltage Switch to the proper control voltage setting before applying voltage to the control circuit.

2.3.2 – Wiring Diagram for In-Delta Connection of Motors

For “In-Delta” connections, set the SR44 Parameter #6 (“Firing Mode”) to “1” (“Delta”).

Figure 2.3.2: Wiring Diagram for In-Delta Connection of 6-Lead Motors

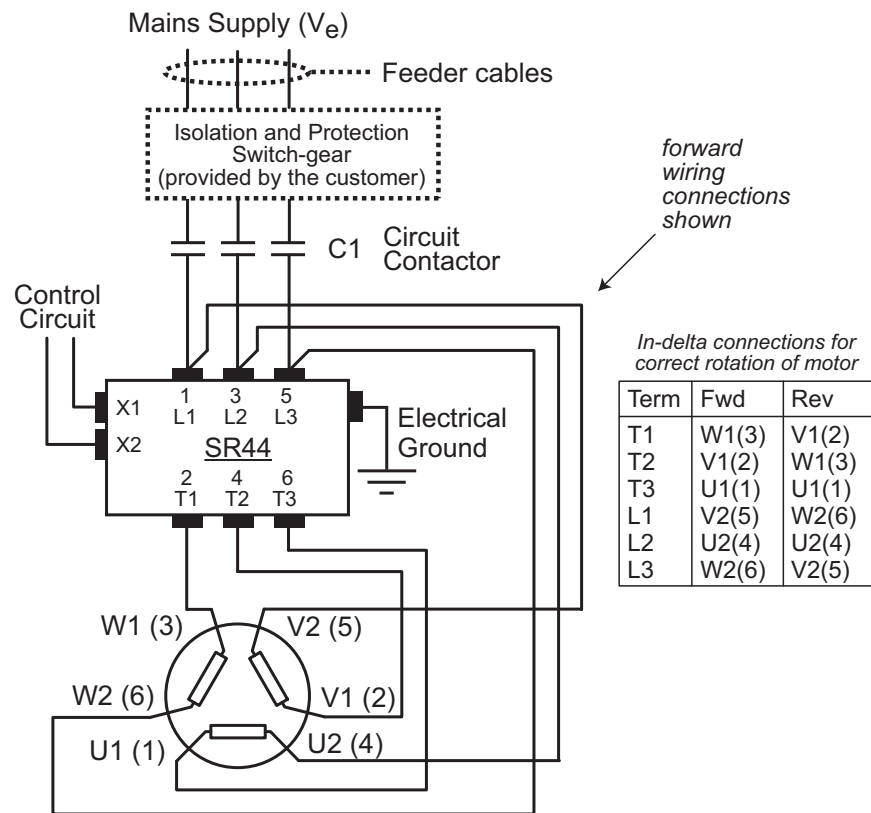

An in-line isolation contactor controlled by the soft starter **MUST** be used with the In-Delta Firing Mode and motor connections. (C1 as shown in Figure 2.3.2)

2.4 – Motor Control Circuits

2.4.1 – Bypass Control

A separate bypass contactor may be connected in parallel with an SR44 Soft Starter. The bypass contactor allows a solid connection of the motor to the Main Supply, which will eliminate the heating effect associated with Soft Starter thyristor losses. Soft-Starting and Soft-Stopping remain active as normal when the wiring is configured as in Figure 2.4.1.

At the completion of the starting ramp a bypass contactor is closed around the main power supply connections of the Soft Starter to remove the thyristors from the circuit. The contactor is controlled by a programmable relay set as 'Bypass Relay', which is the default for relay K2. This configuration ensures that bypassing only occurs after the Soft Starter has completed the start (P8/B3=1), and the motor terminal voltage is at supply voltage.

The default configuration will detect the use of a bypass contactor when using this circuit arrangement, since "Auto bypass" is set as standard. You can also pre-set the protection mode to either "START+BYPASS" or "PHASE LOSS ONLY" for motor bypassing configurations.



When using a bypass contactor, the "Auto Bypass" Auto Feature should be ON (P18/B2; P86/B2). Using a bypass contactor with Auto Bypass in the OFF state can cause thyristor faults.



An external user-supplied current transformer is required if any of the current or power related trip or monitoring features are needed in bypass mode. (Parameters: 8/B2, 9/B1/B2, 20, 21, 22, 23, 26, 28, 30, 32, 33, 34, 36, 39, 51/B1/B2/B3/B4, 87, 89, 91, 93, 112/B0/B1/B2/B3/B6, 121/B4) CT must be installed in the L3-T3 power phase OUTSIDE of the bypass circuit. See control section 2.5.2.

Figure 2.4.1: Power and Contactor Control Circuits for Motor Bypassing

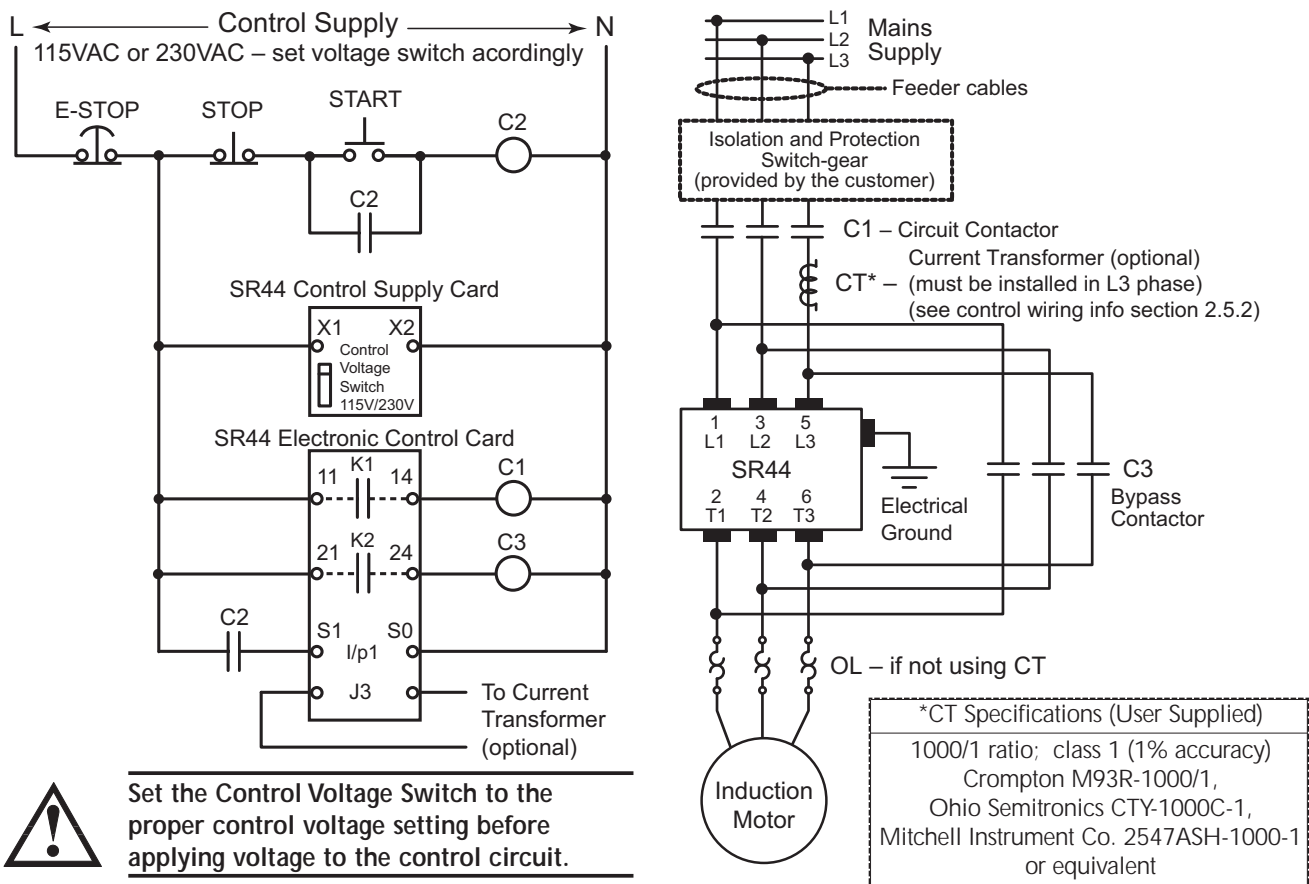

Set the Control Voltage Switch to the proper control voltage setting before applying voltage to the control circuit.

2.4.2 – Multiple Motor Starting & Stopping

The SR44 is capable of starting parallel-connected motors simultaneously, provided each motor has similar characteristics and load. For such configurations the unit rating should be at least the sum of the current ratings of all the motors.

Alternatively, the SR44 can start and stop motors sequentially using bypass contactors under the control of the programmable relay set as a 'Top of Ramp' relay. The dual setting feature allows for the control of motors with different start-up requirements.

2.4.3 – External Motor Protection Relay

The rating for a motor protection relay should be for Direct-on-Line (DOL) starting, and if it is an electronic relay, then the user should confirm its suitability for use with a soft-starter. If the motor load is high-inertia (extended start time), then a longer trip time may be required.

2.4.4 – Motor Reversing

The diagram in figure 2.4.6 shows a typical motor reversing circuit using two contactors, C1 and C2, to interchange two phases of the 3-phase power supply connections.

For this application the soft stop must be set to zero.

We also recommend the following:

- A period of 150 - 350 ms elapses between the FORWARD and REVERSE commands.
- If the reversing rate is high, the SR44 current rating may need to be increased compared to the operational current of the motor. Refer to sections 2.10.3 & 2.10.4, and also the Overcurrent trip curves shown in section 2.10.5.
- The current limit and the overload must be set with more consideration to the "reverse" function rather than the "start", as the motor will initially be "plug braked" then be stationary for a moment and finally undergo a normal soft start.

2.4.6 – Wiring Diagram for Motor Reversing

Figure 2.4.6: Typical Power and Contactor Control Circuits for Motor Reversing

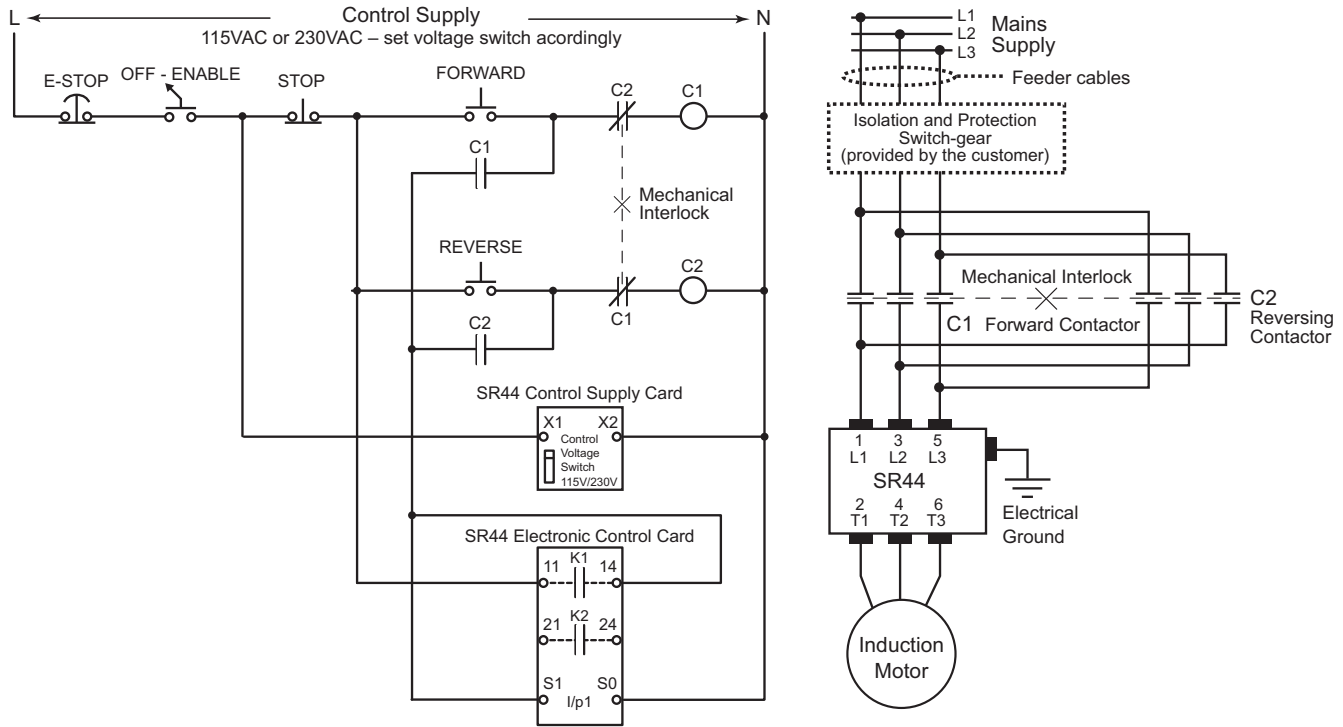

Important:
 Be sure to set the Control Voltage Switch to the proper control voltage setting before applying voltage to the control circuit.

2.5 – Electrical Connections - Terminal Locations

2.5.1 – General Electrical Connections

Figure 2.5.1a: SR44 Chassis Size 1 Electrical Connections

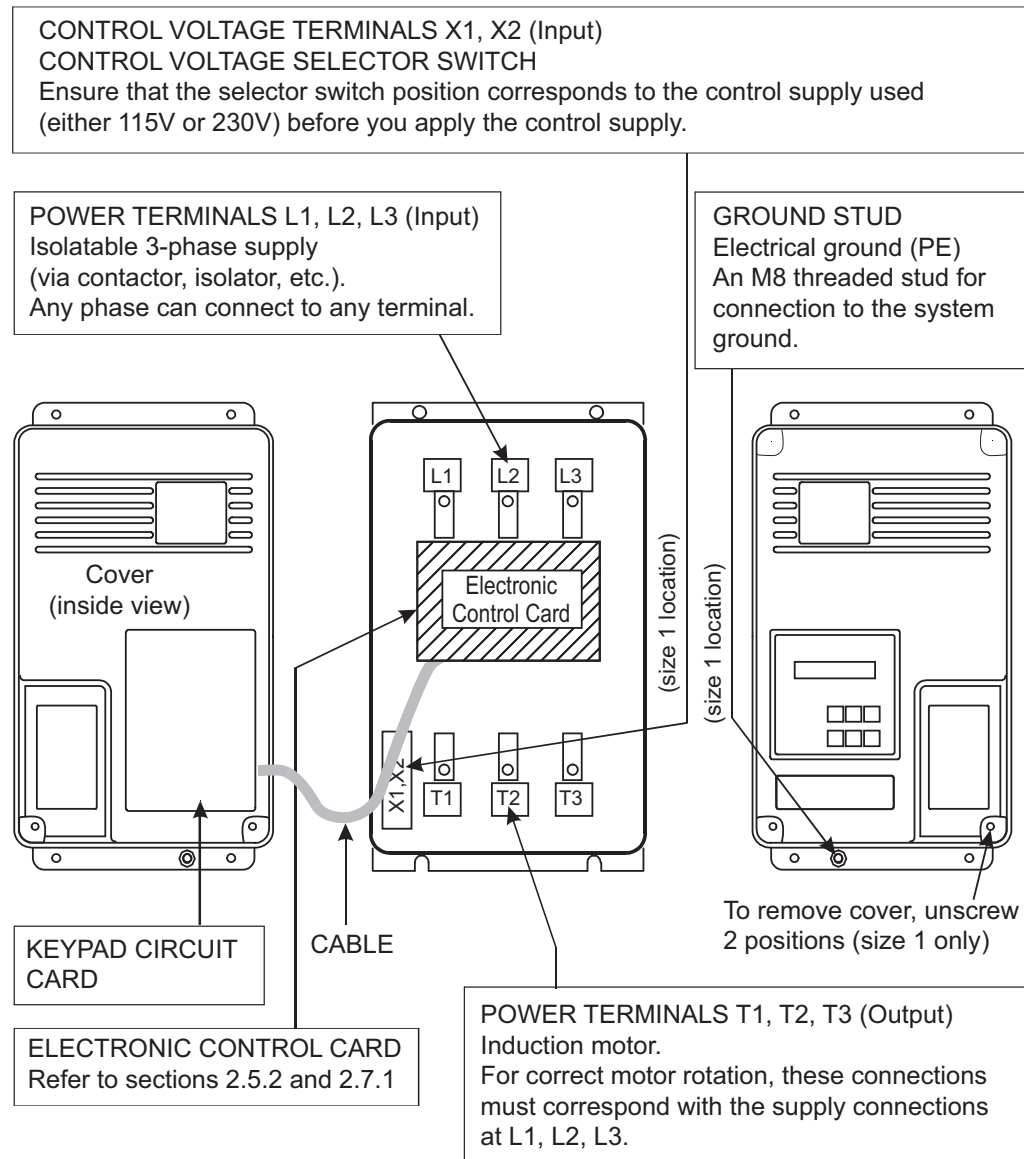

When removing and replacing the front cover, take care not to damage the cable that connects the Keypad and the Electronic Control Card.



The cable from the Keypad to the Electronic Control Card must be connected or disconnected ONLY when the control power is turned OFF to the unit. Otherwise the circuitry may be damaged.

2.5.1 – General Electrical Connections (continued)

Figure 2.5.1b: SR44 Chassis Size 2 Electrical Connections

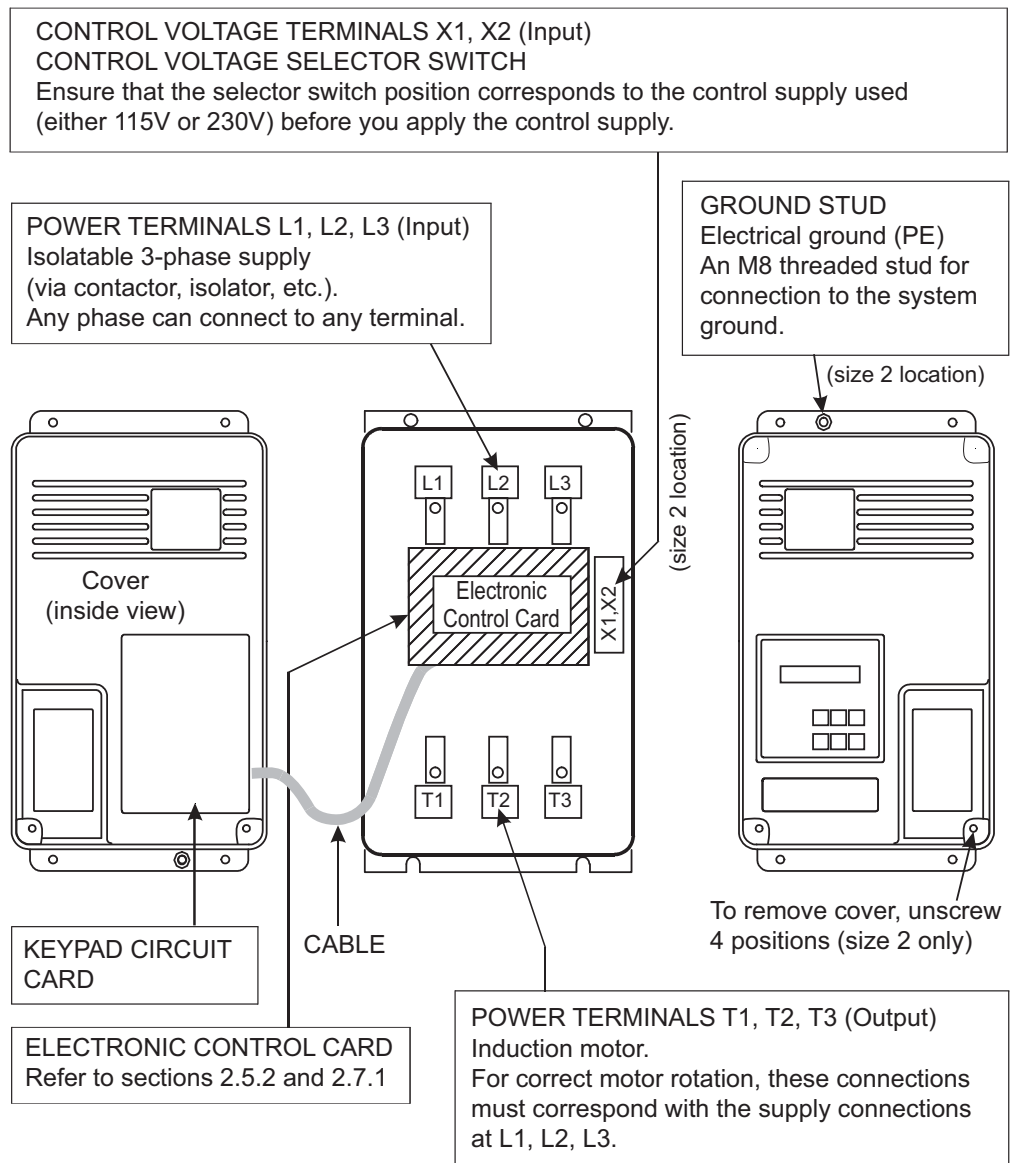

When removing and replacing the front cover, take care not to damage the cable that connects the Keypad and the Electronic Control Card.



The cable from the Keypad to the Electronic Control Card must be connected or disconnected **ONLY** when the control power is turned OFF to the unit. Otherwise the circuitry may be damaged.

2.5.2 – Electronic Control Card

Figure 2.5.2: Electronic Control Card Electrical Connections

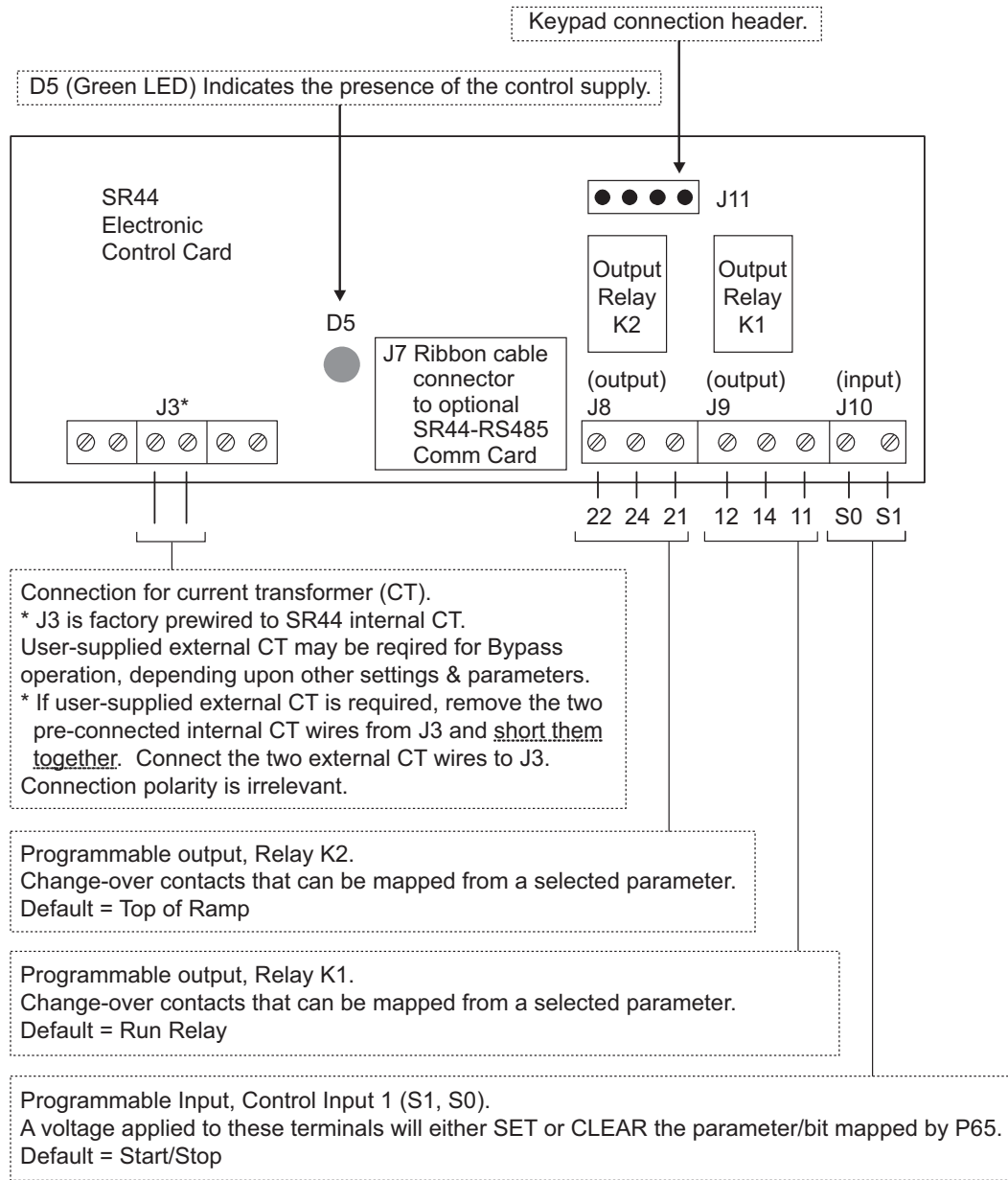

2.6 – Power Supply Connections

2.6.1 – Power Circuit Electrical Supply

Power terminals 1 (L1), 3 (L2), 5 (L3) on all units must be connected to a balanced 3-phase, 3-wire AC power supply that is within the limits specified below.

SR44 Power Electrical Tolerances	
	Nominal Supply Voltage Range
Rated Operational Voltage (V_e) 230V/460V	230V -15% to 460V +10% (usable on 208V systems down to 196V)
Rated Frequency (Hz)	50/60 +/- 2Hz

Phase sequence:

The SR44 will operate with any 3-phase rotation sequence. It is important however, to ensure that the correct connections are made when used with a rotation sensitive load.

2.6.2 – Motor Connections

The motor connects to terminals 2 (T1), 4 (T2), 6 (T3). All SR44 units will control any standard 3-phase squirrel-cage induction motor capable of operating satisfactorily when connected to the main supply with its normal load coupled.

2.6.3 – Control Circuit Electrical Supply

All units require a separate 2-wire, single-phase supply connected to terminals X1 and X2. At the Control Voltage Selector Switch, the user can select either 115V or 230V. The diagrams in section 2.5 show the location of the terminals X1 and X2 for each model of SR44.

Supply voltage must be in the range 115V (-15%, +10%) or 230V (-15%, +10%).



1. The control supply requires external fuse protection.
2. Ensure that the control Voltage selector switch is set correctly before applying power.

SR44 Control Power Consumption						
Chassis Size	Soft Starter Model	Current Rating	Nominal Power Consumption	115V Fuse	230V Fuse	Fuse Type
Size 1	SR44-9 to SR44-23	up to 23A	8VA	125 mA	63mA	CC
	SR44-30 to SR44-44	30A & 44A	10 VA	200 mA	100 mA	
	SR44-59 to SR44-146	59A to 146A	12 VA			
Size 2	SR44-174 to SR44-370	174A to 370A	18 VA			

2.7 – Control Card Connections

All the control inputs and outputs are on the Electronic Control Card (ELC), which is mounted within the unit. Diagrams in section 2.5 show the location of the electronic control card.

2.7.1 – Control Inputs

Control Card Inputs	
Identification	Description
Start/Stop 12/24 VDC or 115/230 VAC	<p>Programmable Input, Control Input 1. (S1, S0)</p> <p>Application of a voltage between S1 and S0 will either SET (normal logic sense) or CLEAR (inverted logic sense) the parameter mapped to by parameter P65.</p> <p>Removal of this voltage will either CLEAR (normal logic sense) or SET (inverted logic sense) the parameter mapped to by parameter P65.</p> <p>Default setting is P52, Bit 4: Start/Stop, which is active only when the operator selects and enters REMOTE STARTING at the keypad.</p> <p>The application of a voltage, as specified, between these terminals, will initiate a START. The removal of this voltage will initiate a STOP.</p>

2.7.2 – Control Outputs

Control Card Outputs	
Identification	Description
12, 14, 11	<p>Programmable Output, Relay K1.</p> <p>A bit = 1 on the parameter/bit selected by P57 makes Relay K1 ACTIVE (normal logic sense) or INACTIVE (inverted logic sense).</p> <p>Default setting is P52, Bit 5: Main Contactor</p> <p>Relay change-over contacts: Contact rating: 230VAC, 3A, AC1 ; 24VDC, 3A 11 – Common; 12 – Normally-closed; 14 – Normally-open</p>
22, 24, 21	<p>Programmable Output, Relay K2.</p> <p>A bit = 1 on the parameter/bit selected by P59 makes Relay K2 ACTIVE (normal logic sense) or INACTIVE (inverted logic sense).</p> <p>Default setting is P8, Bit 3: Top of Ramp or Full Volts</p> <p>Relay change-over contacts: Contact rating: 230VAC, 3A, AC1 ; 24VDC, 3A 21 – Common; 22 – Normally-closed; 24 – Normally-open</p>

2.8 – (Reserved for Future Use)

2.9 – Typical Motor Power at Rated Voltage

The amperage values for the Soft Starter are the maximum continuous current for the model.

The motor ratings are the nearest values for the output powers of standard squirrel-cage motors below the unit current rating of the SR44.

The currents (amps) quoted are for 3-phase, 4-pole motors operating on 50/60Hz power supplies. Actual currents of motors may vary by $\pm 10\%$ depending on size and manufacturer. Motors of lower speeds generally draw higher currents for the same rated output. Typically +10% for 6-pole or +20% for 8-pole as compared to 4 pole motors.

Motor ratings are in kiloWatts (kW) as defined by the IEC or Horsepower (HP) as defined by the American "National Electrical Code" and are, where possible, normal motor sizes.

2.9.1 – Chassis Size 1 Motor Power Ratings

SR44 Chassis Size 1 Motor Power Ratings									
Model	Current (Amps)	208 Volts *		230 Volts		400 Volts		460 Volts	
		kW	HP	kW	HP	kW	HP	kW	HP
SR44-9	9	1.5	2	2.2	3	4	5	4	5
SR44-16	16	2.2	3	3.7	5	7.5	10	7.5	10
SR44-23	23	3.75	5	6.3	7.5	11	15	11	15
SR44-30	30	5.5	7.5	7.5	10	15	20	15	20
SR44-44	44	7.5	10	11	15	22	30	22	30
SR44-59	59	11	15	16	20	30	40	32	40
SR44-72	72	15	20	20	25	37	50	40	50
SR44-85	85	18.5	25	22	30	45	60	45	60
SR44-105	105	22	30	30	40	55	75	55	75
SR44-146	146	37	50	45	60	75	100	80	100

** 208V applications are UL listed only as low as 196V.*

2.9.2 – Chassis Size 2 Motor Power Ratings

SR44 Chassis Size 2 Motor Power Ratings									
Model	Amps	208 Volts *		230 Volts		400 Volts		460 Volts	
		kW	HP	kW	HP	kW	HP	kW	HP
SR44-174	174	45	60	55	75	90	100	110	150
SR44-202	202	45	60	63	75	110	150	132	175
SR44-242	242	55	75	75	100	132	175	150	200
SR44-300	300	75	100	90	100	160	200	185	250
SR44-370	370	90	125	110	150	200	250	220	300

** 208V applications are UL listed only as low as 196V.*

2.10 – Fuse and Current Ratings

2.10.1 – Full-Load Current Limit and Short-Circuit Protection

SR44 Fuse and Current Ratings for UL Applications (Table 2.10.1)					
Model	I_e (A _{RMS})	Short Circuit Current (RMS)	UL Recognized JFHR2 Fuse		
			Bussman Model #	Ferraz Model #	Amps
SR44-9	9	5kA	170M3110	6.9 URD 30 D08A 0063	63
SR44-16	16				
SR44-23	23				
SR44-30	30				
SR44-44	44				
SR44-59	59				
SR44-72	72	10 kA	170M3116	6.9 URD 30 D08A 0250	250
SR44-85	85				
SR44-105	105				
SR44-146	146				
SR44-174	174				
SR44-202	202				
SR44-242	242	18 kA	170M4114	6.9 URD 31 D08A 0500	500
SR44-300	300				
SR44-370	370				

These fuses are for short circuit protection of the semiconductors, and must be mounted externally by the user between the unit and the main power supply.

UL requires Recognized special purpose fuses (JFHR2) for the protection of semi-conductor devices, rated 700 VAC, as indicated in Table 2.10.1, be used to obtain the short circuit ratings required by UL.

Suitable for use on a circuit capable of delivering not more than the RMS Symmetrical Amperes indicated in Table 2.10.1 at maximum rated operational voltage when protected by Semiconductor Fuse type, Manufactured by Company and Model Number indicated in Table 2.10.1

Fuse rated 700 VAC, Amps as indicated in Table 2.10.1.

It is the responsibility of the installer and system designer/specifier to ensure that the required standards or regulations are not affected by so doing.

2.10.1 – Full-Load Current Limit and Short-Circuit Protection (continued)

SR44 Fuse and Current Ratings for Non-UL Applications*					
Model	I _e (A _{RMS})	Short Circuit Current (RMS)	Fuse		
			Bussman FWP 700V Model #	Edison E70S Model #	Amps
SR44-9	9	5kA	FWP-50B	E70S50	50
SR44-16	16				
SR44-23	23				
SR44-30	30		FWP-80B	E70S80	80
SR44-44	44				
SR44-59	59				
SR44-72	72	10 kA	FWP-125A	E70S125	125
SR44-85	85				
SR44-105	105				
SR44-146	146		FWP-200A	E70S200	200
SR44-174	174				
SR44-202	202				
SR44-242	242	FWP-300A	E70S300	300	
SR44-300	300				
SR44-370	370				
		18 kA	FWP-400A	E70S400	400
			FWP-500A	E70S500	500
			FWP-700A	E70S700	700

Use these fuses with SR44 soft starters only in NON-UL applications.

2.10.2 – External Fuse Requirements

The rating of HRC (High Rupturing Capacity) fuses for motor protection needs to be carefully analyzed when using a Soft Starter due to the longer start times which are involved. When high inertia loads (e.g. fans) are being started, special consideration should be given to fuse ratings due to the extended ramping times. Most fuse manufacturers have an “extended start” or “dual element” range of fuses intended for this type of application.

The advantage of an HRC fuse becomes evident during a fault current condition. As a result of the high current, large amounts of heat are created within the fuse, melting the filling of the fuse into glass. Being an insulator, glass suppresses arc-over and breaks the circuit instantly. This behavior minimizes the possibility of a continuing, dangerous high arc current.

For semiconductor protection fusing, refer to the table in section 2.10.1.

2.10.3 – Overload Current Profile and Duty Cycle AC-53a

IEC 60947-4-2 Motor Utilization Category: AC-53a (not operating in bypass mode)

SR44 Index Ratings (for AC-53a) *				
Soft Starter Model Number	I _e (A)	Standard Operation		
		UC	X-T _x	F-S
SR44-9 to SR44-105	9 to 105	AC-53a AC-53a	5-4 3-35	99-10 99-10
SR44-146 to SR44-202	146 to 202	AC-53a AC-53a	4-6 3-35	99-10 99-10
SR44-242 to SR44-370	242 to 370	AC-53a AC-53a	4-6 3-35	60-3 60-3

* Index ratings AC-53a and AC-53b are specified by IEC standard # 60947-4-2

IEC Index Ratings for standard operation are comprised of Rated Operational Current (I_e), Utilization Category AC-53a, Overload Current Profile (X-T_x), and Duty Cycle (F-S).

AC-53a Overload Current Profiles (applicable to specified Soft Starter models)				
Soft Starter Model	X Overload Current (multiple of I _e)	T _x Duration of Overload (seconds)	F Ratio of On-load Period to Total Load (%)	S Number of Operating Cycles per Hour
SR44-9 to SR44-105	3	35	99	10
	5	4	99	10
SR44-146 to SR44-202	3	35	99	10
	4	6	99	10
SR44-242 to SR44-370	3	35	60	3
	4	6	60	3

To calculate times for a lower value of current, divide the square of the next highest given current multiplied by its given time by the square of the required current.

For example:

- To find the time T_x for X = 2.5 x I_e, then T_x = (3² x 35) / (2.5)² = 50 seconds.

Index Rating Example – Standard Operation (AC-53a Utilization Category per IEC 60947-4-2)

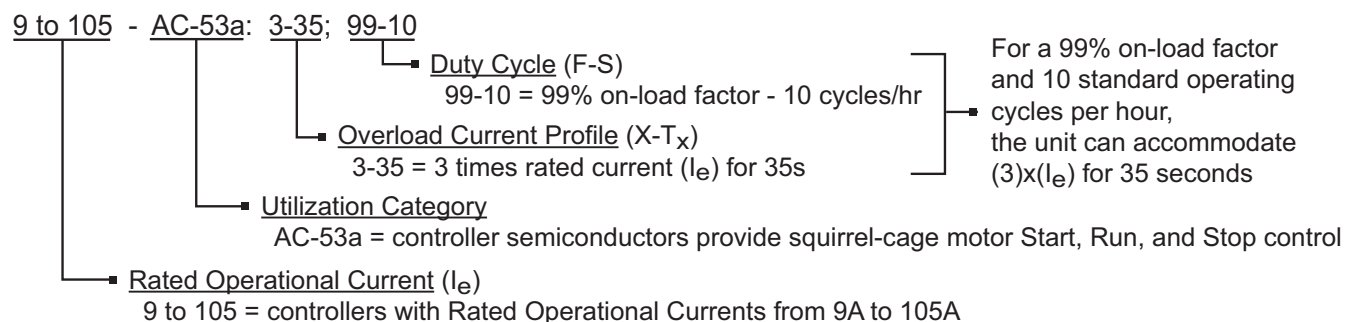

2.10.4 – Overload Current Profile AC-53b

IEC 60947-4-2 Motor Utilization Category: AC-53b (operating in bypass mode)

SR44 Index Ratings (for AC-53b) *				
Soft Starter Model Number	I _e (A)	Bypassed Operation		
		UC	X-T _x	OFF-time
SR44-9 to SR44-105	9 to 105	AC-53b AC-53b	5-4 3-35	120 120
SR44-146 to SR44-202	146 to 202	AC-53b AC-53b	4-6 3-35	120 120
SR44-242 to SR44-370	242 to 370	AC-53b AC-53b	4-6 3-35	420 420

* Index ratings AC-53a and AC-53b are specified by IEC standard # 60947-4-2

IEC Index Ratings for bypassed operation are comprised of Rated Operational Current (I_e), Utilization Category AC-53b, Overload Current Profile (X-T_x), and OFF-time.

AC-53b Overload Current Profiles (applicable to specified Soft Starter models)			
Soft Starter Model	X Overload Current (multiple of I _e)	T _x Duration of Overload (seconds)	OFF-Time (seconds)
SR44-9 to SR44-105	3	35	120
	5	4	120
SR44-146 to SR44-202	3	35	120
	4	6	120
SR44-242 to SR44-370	3	35	420
	4	6	420

Index Rating Example – Bypassed Operation (AC-53b Utilization Category per IEC 60947-4-2)

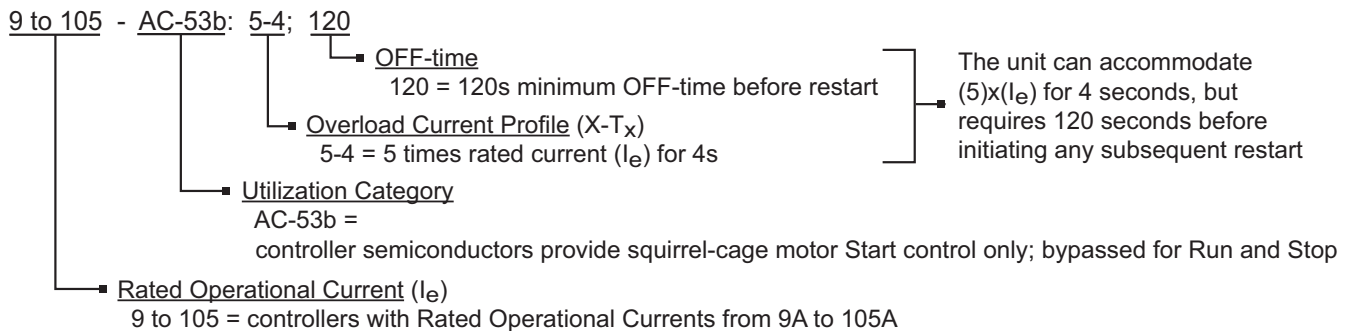

2.10.5 – Overcurrent Trip Graph

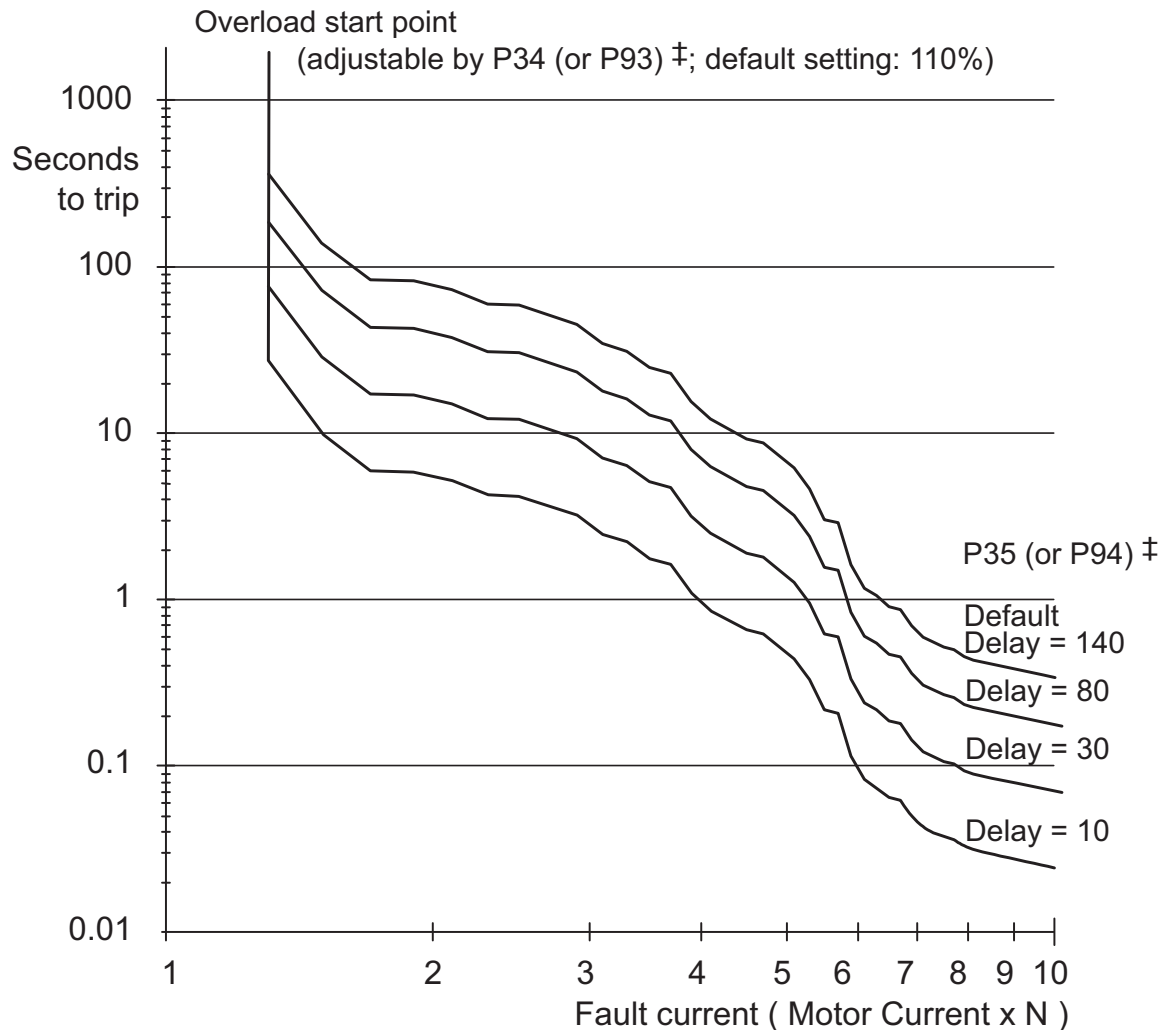

‡ Parameter selected through either the primary or secondary group of value parameters

'Current Limit', 'Overload Level' and 'Overload Delay' settings may be adjusted to limit overload currents in accordance with the trip curves shown in the Overload Trip Graph.

For motors with Full Load Currents lower than the rated current of the SR44, the Overload Level can be adjusted using the following formula:

$$\text{Overload Level} = \text{Motor FLC} \times 1.1 \text{ (A)}$$



The Overload monitors only one of the phases, and the 'Current Limit' level is only active during motor starting.



We recommend that the control power supply be maintained between starts to ensure the integrity of the Overload, which will reset on removal of control power.

**BLANK
PAGE**