

# CE–EMC Installation Guidelines



---

In This Appendix....	page
— CE–EMC Installation Guidelines.....	2
— Hitachi EMC Recommendations.....	4

# CE-EMC Installation Guidelines

You are required to satisfy the EMC directive (89/336/EEC) when using an SJ300 inverter in an EU country. To satisfy the EMC directive and to comply with standard, follow the guidelines in this section.

- 1. As user you must ensure that the HF (high frequency) impedance between adjustable frequency inverter, filter, and ground is as small as possible.**
  - Ensure that the connections are metallic and have the largest possible contact areas (zinc-plated mounting plates).
- 2. Avoid conductor loops that act like antennas, especially loops that encompass large areas.**
  - Avoid unnecessary conductor loops.
  - Avoid parallel arrangement of low-level signal wiring and power-carrying or noise-prone conductors.
- 3. Use shielded wiring for the motor cable and all analog and digital control lines.**
  - Allow the effective shield area of these lines to remain as large as possible; i.e., do not strip away the shield (screen) further away from the cable end than absolutely necessary.
  - With integrated systems (for example, when the adjustable frequency inverter is communicating with some type of supervisory controller or host computer in the same control cabinet and they are connected at the same PE-potential), connect the shields of the control lines to ground + PE (protective earth) at both ends. With distributed systems (for example the communicating supervisory controller or host computer is not in the same control cabinet and there is a distance between the systems), we recommend connecting the shield of the control lines only at the end connecting to the adjustable frequency inverter. If possible, route the other end of the control lines directly to the cable entry section of the supervisory controller or host computer. The shield conductor of the motor cables always must be connected to PE at both ends.
  - To achieve a large area contact between shield and PE-potential, use a PG screw with a metallic shell, or use a metallic mounting clip.
  - Use only cable with braided, tinned copper mesh shield (type “CY”) with 85% coverage.
  - The shielding continuity should not be broken at any point in the cable. If the use of reactors, contactors, terminals, or safety switches in the motor output is necessary, the unshielded section should be kept as short as possible.
  - Some motors have a rubber gasket between terminal box and motor housing. Very often, the terminal boxes, and particularly the threads for the metal PG screw connections, are painted. Make sure there is always a good metallic connection between the shielding of the motor cable, the metal PG screw connection, the terminal box, and the motor housing. If necessary, carefully remove paint between conducting surfaces.
- 4. Take measures to minimize interference that is frequently coupled in through installation cables.**
  - Separate interfering cables with 0.25m minimum from cables susceptible to interference. A particularly critical point is laying parallel cables over longer distances. If two cables intersect (one crosses over the other), the interference is smallest if they intersect at an angle of 90°. Cables susceptible to interference should therefore only intersect motor cables, intermediate circuit cables, or the wiring of a rheostat at right angles and never be laid parallel to them over longer distances.
- 5. Minimize the distance between an interference source and an interference sink (interference-threatened device), thereby decreasing the effect of the emitted interference on the interference sink.**
  - You should use only interference-free devices and maintain a minimum distance of 0.25 m from the adjustable frequency inverter.

### 6. Follow safety measures in the filter installation.

- Ensure that the protective earth terminal (PE) of the filter is properly connected to the PE terminal of the adjustable frequency inverter. An **HF ground connection** via metal contact between the housings of the filter and the adjustable frequency inverter, or solely via cable shield, *is not permitted as a protective conductor connection*. The filter must be *solidly and permanently connected with the ground potential* so as to preclude the danger of electric shock upon touching the filter if a fault occurs.

To achieve a protective ground connection for the filter:

- Ground the filter with a conductor of at least 10 mm<sup>2</sup> cross-sectional area.
- Connect a second grounding conductor, using a separate grounding terminal parallel to the protective conductor. (The cross section of each single protective conductor terminal must be sized for the required nominal load.)

SJ300 inverter with footprint-type filter

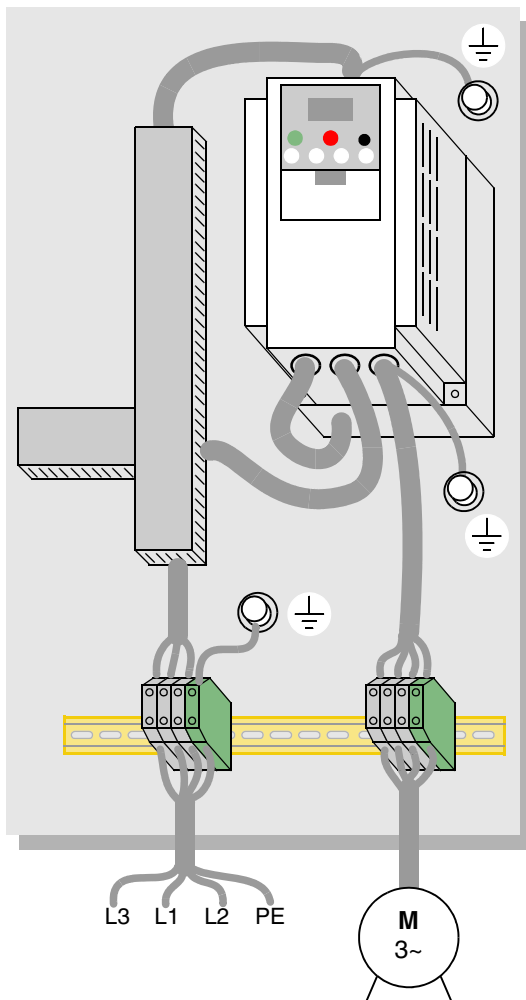

SJ300 inverter with book-type filter

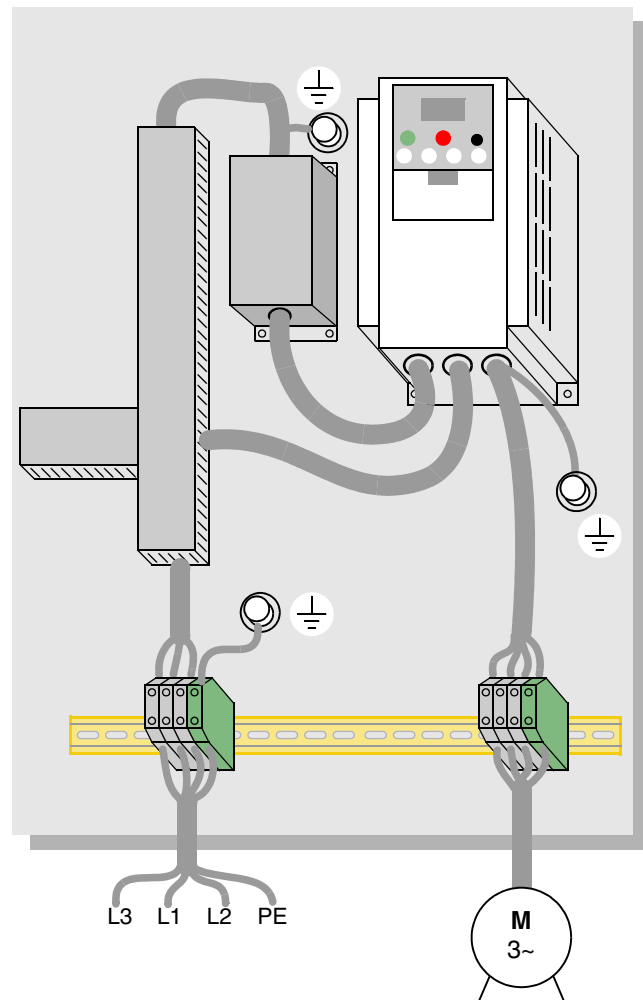

# Hitachi EMC Recommendations



---

**WARNING:** This equipment should be installed, adjusted, and serviced by qualified personal familiar with construction and operation of the equipment and the hazards involved. Failure to observe this precaution could result in bodily injury.

---

Use the following checklist to ensure the inverter is within proper operating ranges and conditions.

1. The power supply to SJ300 inverters must meet these specifications:
  - Voltage fluctuation +/- 10% or less
  - Voltage imbalance +/- 3% or less
  - Frequency variation +/- 4% or less
  - Voltage distortion THD = 10% or less
2. Installation measure:
  - Use a filter designed for SJ300 inverter.
3. Wiring:
  - Shielded wire (screened cable) is required for motor wiring, and the length must be less than 50 meters.
  - The carrier frequency setting must be less than 5 kHz to satisfy EMC requirements.
  - Separate the power input and motor wiring from the signal/process circuit wiring.
4. Environmental conditions—when using a filter, follow these guidelines:
  - Ambient temperature: -10 to 40 °C
  - Humidity: 20 to 90% RH (non-condensing)
  - Vibration:  $5.9 \text{ m/sec}^2$  (0.6 G) 10 ~ 55Hz, SJ300-004xxx to SJ300-220xxx  
 $2.94 \text{ m/sec}^2$  (0.3 G) 10 ~ 55Hz, SJ300-300xxx to SJ300-1500xxx
  - Location: 1000 meters or less altitude, indoors (no corrosive gas or dust)