



Micro Detectors

Ultrasonic Distance Sensor
Ultraschall Abstandssensor
Capteurs Ultrasoniques

SU1-B0-0A

Technical Data	Technische Daten	Données techniques	
Max. sensing distance Min. sensing distance Switching frequency Hysteresis Beam angle Temperature range Operating voltage Current consumption	Max. Reichweite Min. Reichweite Schaltfrequenz Hysteresis Schallkeule Temperaturbereich Betriebsspannung Stromaufnahme	Portée Distance minimale Fréquence de commutation Hysteresis Angle de faisceau Température de service Tension de service Courant consommé	600 mm 100 mm 25 Hz 2% 8 ° -15 ... +70 °C 18... 30 Vdc < 35 mA
Output Output current Adjustment set point Control input inhibit connect to: synchronisation connect to: enable connect to:	Ausgang Ausgangsstrom Schaltpunkteinstellung Steuereingang Sperrverbinde mit: Synchronisation verbinde mit: Freigabe verbinde mit:	Sortie Courant sortie Reglage du position seuil Entrée de contrôle Invalidation Synchronisation Validation	PNP NO 500 mA max. Pot Pink/Rosa/Rosé → 0V ↔ Pink/Rosa/Rosé → NC
Plastic housing Sealing Cable termination	Kunststoffgehäuse Schutzart Kabelanschluß	Boîtier plastique Etanchéité Cable	M18x1 IP67 2 m

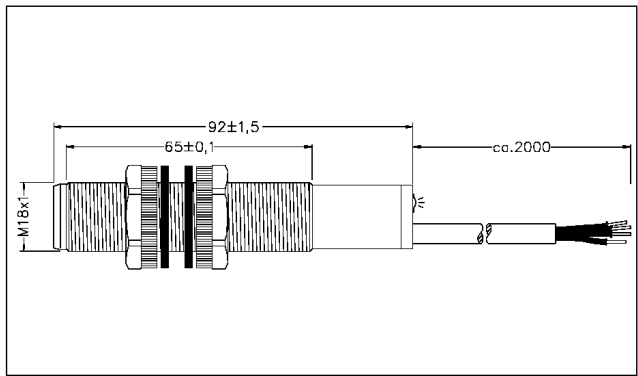
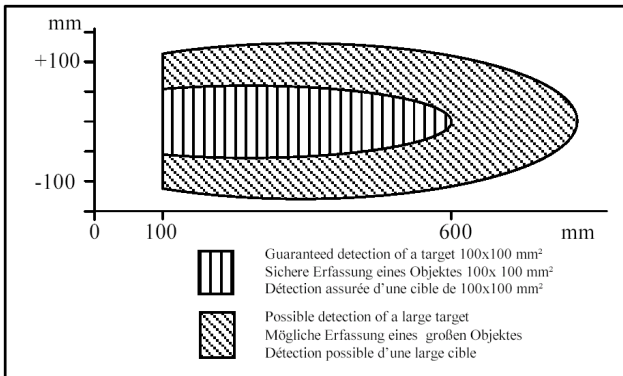

Detection range / Erfassungsbereich/ Plage de détection mm Dimensions/ Abmessungen/ Dimensions mm

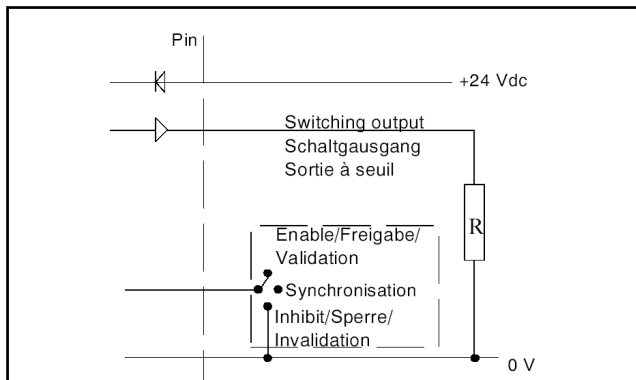

+24VDC: Brown/ Braun/ Maron
 Output: Black/ Schwarz/ Noir
 HLD/Sync: Pink/ Rosa/ Rose
 0V: Blue/ Blau/ Bleu

<p>!!! WARNING !!! PERSONAL INJURY DO NOT USE these products as safety or emergency stop devices, or in any other application where failure of the product could result in personal injury. Failure to comply with these instructions could result in death or serious injury.</p>	<p>!!! WARNUNG !!! PERSONENSCHADEN Diese Produkte dürfen weder als Sicherheits- oder Not-Abschaltgeräte noch in anderen Anwendungen, bei denen ein Fehler an diesem Produkt zu Personenschaden führen könnte, eingesetzt werden. Missachtung dieser Anweisungen kann zu schweren Verletzungen oder zum Tod führen.</p>	<p>!!! ATTENTION !!! BLESSURES CORPORALES NE PAS UTILISER ces produits en tant que dispositifs d'arrêt d'urgence ou de sécurité, ni dans aucune autre application où la défaillance du produit pourrait entraîner des blessures corporelles. L'Inobservation de ces instructions peut entraîner la mort ou de graves blessures.</p>
---	---	--