

FC-3RLY2 Analog Input, 2-Relay Limit Alarm Module

Product Guide



3505 HUTCHINSON ROAD
CUMMING, GA 30040-5860

Description:

Analog to Relay Limit Alarm module is field configurable for a variety of alarm and control applications. This module can be powered by 24VAC or 24VDC and accept input signals of 0-15V, 0-30V, or 0-20mA. Configuration and Trip/Release Point programming is accomplished with DIP switches, and a single PGM-pushbutton. LED's provide an indication of operating status, and are used during the Trip/Release Point programming. The module can be DIN rail or side mounted.

Version: 1st Ed
March 2016

Specifications

Input Specifications

Number of Inputs and Type	1, Single Ended (1 common)
Input Ranges	0-15VDC, 0-30VDC, 0-20mA, DIP switch selectable
Input Impedance	100K Ω voltage input / 250 Ohms current input
External Power Requirement	* 24VAC or 24VDC@100mA \pm 10%
Low-pass Filtering	-3dB at 100Hz, (-6dB per octave)
Set/Release Point Voltage Repeatability	0.05% of full scale voltage range (constant temperature)
Set/Release Point Current Repeatability	0.1% of full scale current range (constant temperature)

Output Specifications

Relay Contacts	2 SPDT, Form C
Contact Rating	250VAC @ 5A, 30VDC @ 5A (Resistive Load) 380VAC Max., 30VDC Max.
Relay Operation	DIP Switch Selectable
Relay Trip Point Setting	Program mode enabled by pushbutton.
Relay Release Point Setting	
Minimum Relay Dead-band = Trip Point \pm Release Point	0-15VDC range: 1.0% minimum dead-band (150mV); 0-30VDC range: 1.0% minimum dead-band (300mV); 0-20mA range: 3.0% minimum dead band (600uA)

Terminal Block Specifications

Field Wiring	Removable Screw Type Terminal Blocks
Number of Terminal Blocks	2 Two Position (Dinkle: EC350V-02P) 2 Three Position (Dinkle: EC350V-03P)
Wire Range	28-14 AWG Solid or Stranded Conductor
Wire Strip Length	1/4" (6-7 mm)
Screw Torque	1.7 inch-pounds (0.19 Nm)
Surrounding Air Temperature	0 to 60°C (32 to 140°F) IEC 60068-2-14 (Test Nb, Thermal Shock)
Storage Temperature	-20 to 70°C (-4 to 158°F) IEC 60068-2-1 (Test Ab, Cold) IEC 60068-2-2 (Test Bb, Dry Heat) IEC 60068-2-14 (Test Na, Thermal Shock)

Specifications (continued)

Humidity	5 to 95% (non-condensing) IEC 60068-2-30 (Test Db, Damp Heat)
Environmental Air	No corrosive gases permitted (EN61131-2 pollution degree 1)
Vibration	MIL STD 810C 514.2 IEC 60068-2-6 (Test Fc)
Shock	MIL STD 810C 516.2 IEC 60068-2-27 (Test Ea)
Insulation Resistance	>10M Ω @ 500 VDC
Noise Immunity	NEMA ICS3-304 IEC 61000-4-2 (ESD) Impulse 1000V @ 1 μ S pulse IEC 61000-4-4 (FTB) RFI, (145 MHz, 440 MHz 5W @ 15 cm) IEC 61000-4-3 (RFI)
Weight	0.3 lbs
Isolation	1800 VDC Power to Input 1800 VDC Power to Output 1800 VDC Input to Output applied for 1 second (100% Tested)
Agency Approvals	UL508*, File # E157382, CE

* in order to comply with UL508 Class 2 standards the supplied power must be less than 26VDC and fused at a maximum of 3 amps.

Factory Settings

	Range	Trip Point	Release Point (RP = TP - Dead-band)	Dead-band **
INC Mode:	0-15VDC	7.5V	7.125V	2.5% (0.375V)
	0-30VDC	15V	14.25V	2.5% (0.75V)
	0-20mA	N/A*	N/A*	7.5% (1.5mA)
	Range	Trip Point	Release Point (RP = TP + Dead-band)	Dead-band **
DEC Mode:	0-15VDC	7.5V	7.875V	2.5% (0.375V)
	0-30VDC	15V	15.75V	2.5% (0.75V)
	0-20mA	N/A*	N/A*	7.5% (1.5mA)

* No Factory Settings for 0-20mA Input Range.

** (Dead-band % calculated from full range voltage.)

Dimensions mm [inch]

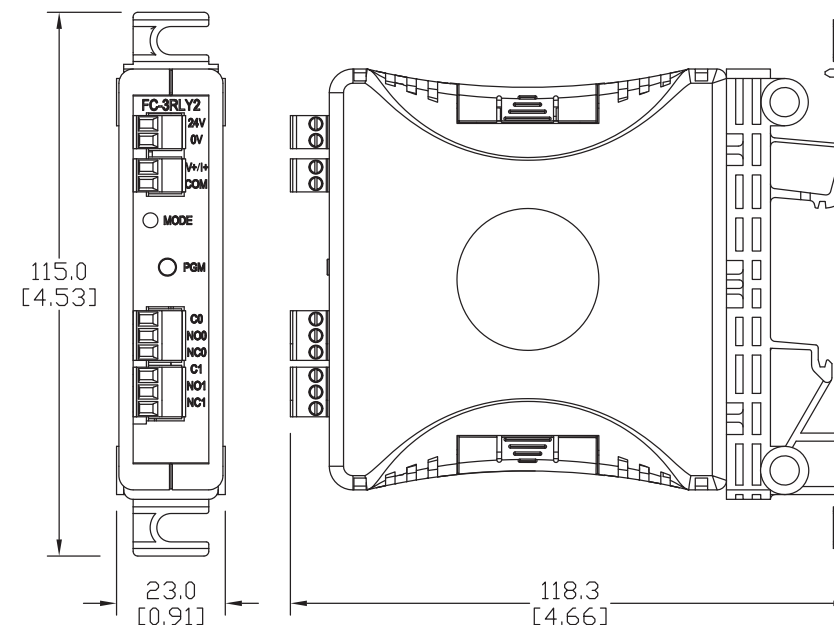

Wiring Connections

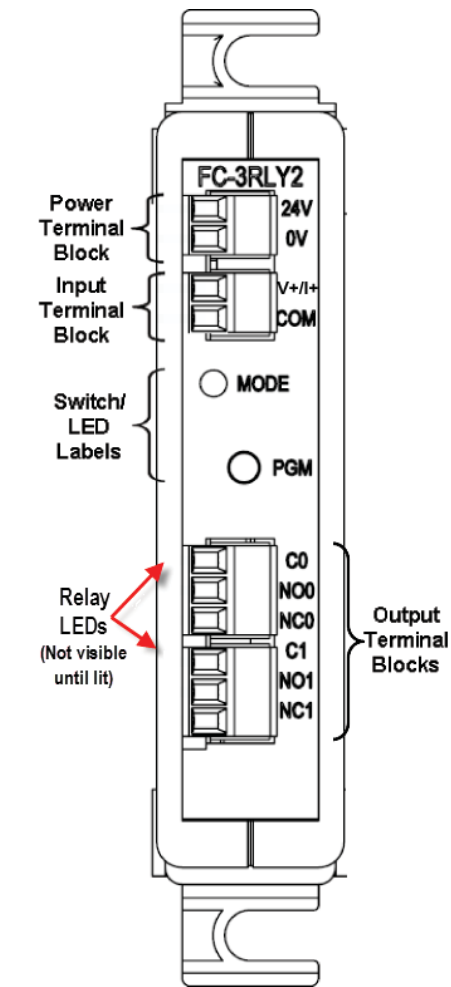

External Power Terminal Block	
Faceplate Label	Description
24V	24VAC/VDC \pm 10%
0V	0V

Input Terminal Block	
Faceplate Label	Description
V+ / I+	Voltage + / Current In
COM	Input Common

Switch / LED Labels	
Faceplate Label	Description
Mode	Programming Diagnostic LED indication
PGM	Pushbutton Switch Input to initiate programming, etc.

Output Terminal Block	
Faceplate Label	Description
C0/NO0/NC0	Common# / Normally Open# / Normally Closed#
C1/NO1/NC1	

Status Indicators

Mode (Green/Red):

- Green LED ON when unit is powered.
- Red LED ON when in Program Mode. Flashes when setting Custom Release Point.
- Flashes Red/Green to indicate a Trip/Release Point programming error.

Trip Points A and B (Red):

- Red ON when a Trip Point is tripped.
- Red LED is ON when setting a Trip Point in Program Mode.
- Flashes Red when setting a Release Point in Program Mode.

To Return to Factory Settings:

- Hold PGM pushbutton down for 10 seconds. Mode LED turns RED and turns completely OFF.
- Release the PGM pushbutton. Mode LED turns GREEN.
- Unit has been successfully returned to Factory Settings values.
- Factory Reset does not function in Programming Mode.

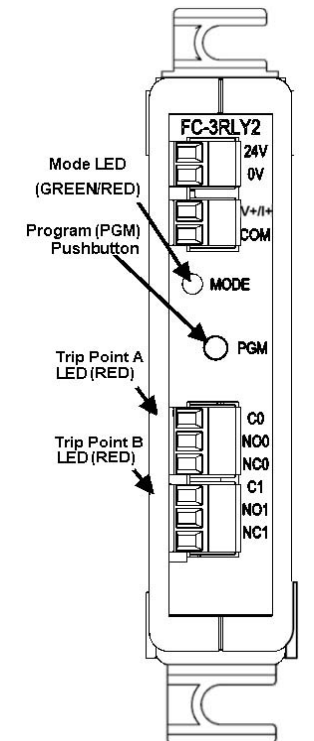

DIP Switch Settings

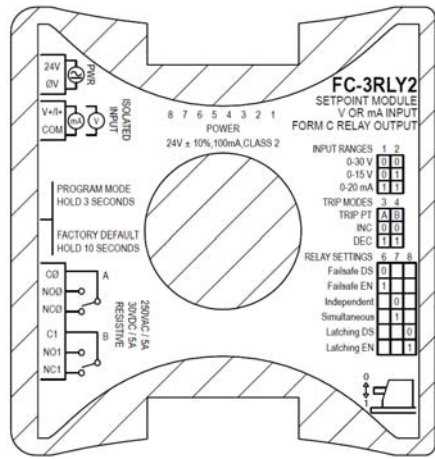

Dip Switches	Switch Positions							
	1	2	3	4	5	6	7	8
Input Ranges								
0-30V	0	0			NA			
0-15V	0	1			NA			
0-20mA	1	1			NA			
Relay Functions								
Trip Point A INC			0		NA			
Trip Point A DEC			1		NA			
Trip Point B INC				0	NA			
Trip Point B DEC				1	NA			
(Normal) Non-failsafe					NA	0		
Failsafe Mode					NA	1		
Independent Relay Control					NA		0	
Simultaneous Relay Control					NA		1	
Non-Latching Relays					NA			0
Latching Relays					NA			1

NOTE: A power cycle, entering programming mode or a factory reset, is required to read DIP Switch changes. All Trip Points MUST be programmed after any DIP Switch change.
NOTE: Factory settings shown in bold.
NOTE: DIP Switch 4 is ignored in Simultaneous Relay Control mode.

WARNING: Disconnect all loads from the output relays BEFORE programming. Output relays can turn ON and OFF during programming causing potentially unsafe conditions if loads are connected!!!

Modes of Operation

Independent and Simultaneous Relay Control Modes:

Independent Relay Control Mode
[DIP Switch 7 OFF]

Relays A and B are controlled with independent Trip Points and Release Points for each relay. Relays A and B can be independently set to operate in Increasing or Decreasing mode (see next section). This mode can be used to control two loads in sequence, or monitor for multilevel alarm conditions.

Relay Control Mode	Dip Switches							
	1	2	3	4	5	6	7	8
Independent Relay Control							0	

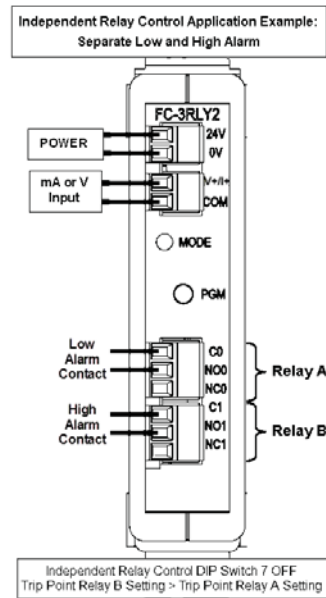

Modes of Operation (continued)

Simultaneous Relay Control Mode
[DIP Switch 7 ON]

Relays A and B operate simultaneously, both controlled by Trip Point A and Release Point A settings. Both relays operate in Increasing or Decreasing mode (see next section) as set by Relay A DIP Switch 3. Relay B DIP Switch 4 is ignored in Simultaneous Relay Control Mode.

This mode can be used where it is desired to have both relays controlled by common Trip and Release points such as using one relay for local alarm indication with a horn or strobe and the other relay for remote alarm monitoring by a PLC.

Relay Control Mode	Dip Switches							
	1	2	3	4	5	6	7	8
Simultaneous Relay Control							1	

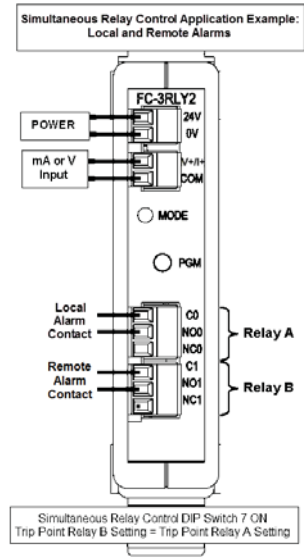

Normal (Non-failsafe) Mode [DIP Switch 6 OFF]

Increasing (INC) Mode
[Relay A: DIP Switch 3 OFF; Relay B: DIP Switch 4 OFF]
The relay will turn ON when the input signal increases to the programmed Trip Point. The relay will remain ON until the input signal decreases below the Release Point. In INC mode, the Trip Point must always be greater than the Release Point (TP > RP).

Relay Control Mode	Dip Switches							
	1	2	3	4	5	6	7	8
Trip Point A INC								
Trip Point B INC								
Normal (Non-failsafe)							0	
Independent Relay Control								0
Non-Latching Relays								0

NOTE: After programming the TP and RP for each relay, the FC-3RLY2 will verify that TP > RP. If TP < RP, the MODE LED will alternately flash green and red. If this occurs simply press and hold the PGM - pushbutton for 3 seconds until the MODE LED turns ON red and reprogram the TP and RP for that relay.

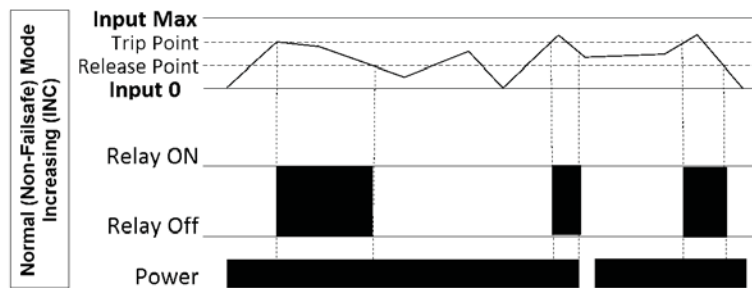

Normal (Non-failsafe) Mode [DIP Switch 6 OFF]
Decreasing (DEC) Mode
[Relay A: DIP Switch 3 ON; Relay B: DIP Switch 4 ON]

The relay will turn ON when the input signal decreases below the programmed Trip Point. The relay will remain ON until the input signal increases above the Release Point. In DEC mode, the Trip Point must always be less than the Release Point (TP < RP).

Relay Control Mode	Dip Switches							
	1	2	3	4	5	6	7	8
Trip Point A DEC								
Trip Point B DEC								
Normal (Non-failsafe)				1				
Independent Relay Control							0	
Non-Latching Relays								0

NOTE: After programming the TP and RP for each relay the FC-3RLY2 will verify that TP < RP. If TP > RP, the MODE LED will alternately flash green and red. If this occurs simply press and hold the PGM - pushbutton for 3 seconds until the MODE LED turns ON red and reprogram the TP and RP for that relay.

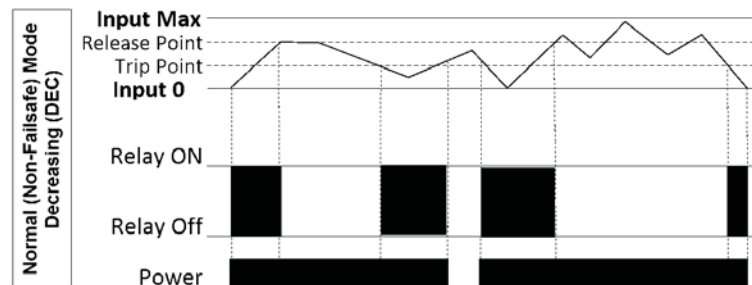

Application Example

Application Example for configuring the FC-3RLY2 as a High and Low Alarm using a 4-20mA input.

This example illustrates how to setup the FC-3RLY2 to provide a HIGH and LOW limit alarm. The HIGH Limit relay [Relay A] will operate at an input value of 15mA and release at 12mA. The LOW limit relay [Relay B] will operate at an input value of 5mA and release at 7mA.

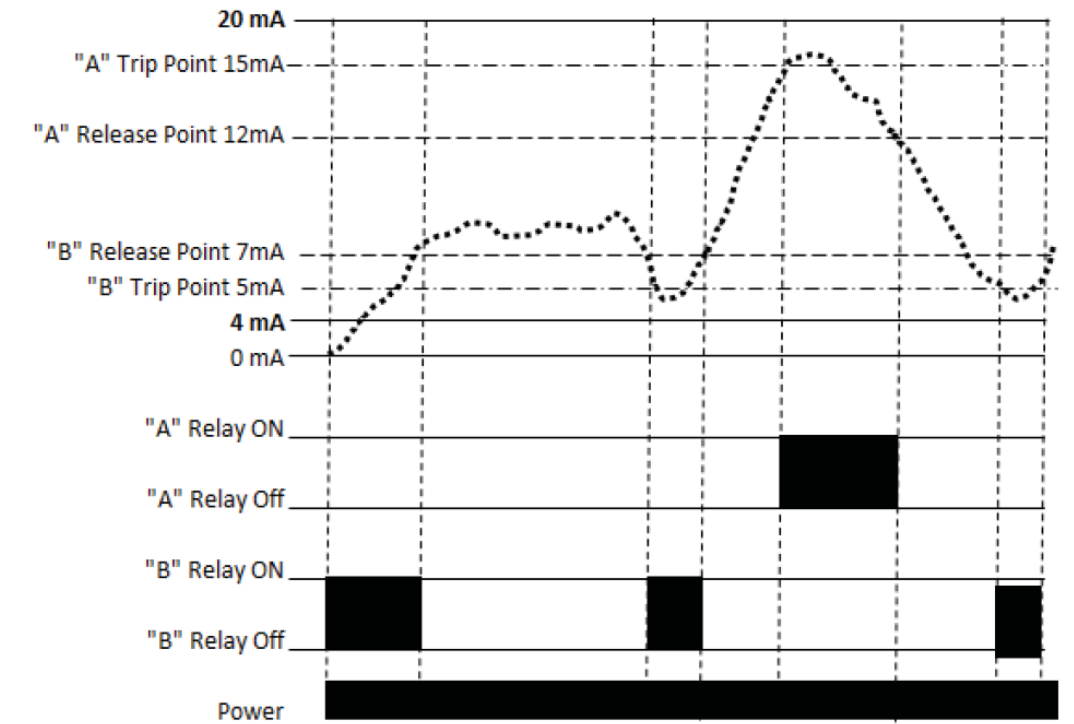

- Set DIP switch settings for 0-20mA input [S1 & S2 = 1], Trip Point A INC [S3 = 0], Trip Point B DEC [S4 = 1] and Independent Relay Control ON [S7 = 0]. All other switches should be set to 0.
- Apply 24VDC power to module by connecting to terminals marked [24V] and [0V]. Connect a mA source to input terminals marked [V+/I+] and [COM].
- Press and Hold "PGM" pushbutton for 3 Seconds. Mode LED changes from GREEN to RED. Relay A LED turns ON.
- For this example adjust the input signal source to 15mA for Relay A Trip Point.
- Press and Release "PGM" pushbutton. Relay A LED flashes to confirm Trip Point A is programmed.
- Press and Hold "PGM" pushbutton for 3 Seconds. Mode LED changes from RED to OFF. Release the "PGM" pushbutton. Relay A LED begins flashing, Mode LED flashes RED.
- Now adjust the input signal for Relay A Release Point to 12mA.
- Press and Release "PGM" pushbutton.
- Relay A LED stops blinking and turns OFF. Relay B LED turns ON.
- Adjust the Input Signal for Relay B Trip Point to 5mA.
- Press and Release "PGM" pushbutton. Relay B LED flashes to confirm Trip Point B is programmed.
- Press and Hold "PGM" pushbutton for 3 Seconds. Mode LED changes from RED to OFF. Release the "PGM" pushbutton. Relay B LED begins flashing, Mode LED flashes RED.
- Lastly, apply 7mA to the input signal for Relay B Release Point.
- Press and Release "PGM" pushbutton.
- Both Relay LEDs turn ON.
- Press and Release "PGM" pushbutton. Mode LED changes from RED to GREEN.
- Custom Trip Point Programming with Custom Release Points completed.
- Test the functionality by applying a mA source to the input and cycling through the range from 15.1mA to 4.9mA. Make sure to note the operation of the relays at the appropriate input values.