



Tongue Switch with Guard Locking KLTM & KLT-SS Operating Instructions



KLTM



KLT-SS

Application:

The RAMZLOCK KLTM and KLT-SS Safety Interlock switch is designed to fit to the leading edge of machine guard doors to provide robust guard locking. They are designed to provide robust position interlock detection for moving guards and will remain locked until the solenoid voltage is applied to the switch. They will hold closed up to 2000N on hinged guards. They can be used in conjunction with delay timers to provide the solenoid energisation only after a pre-determined time has run down.

Operation:

The switch is rigidly mounted to the fixed frame of the guard or machine. The actuator is fitted to the moving part (frame) of the guard and is aligned to the switch entry aperture. The mechanical tongue actuator profile is designed to match a cam mechanism within the switch head and provides a positively operated not easily defeatable mechanical interlock. Only when the actuator is correctly aligned can the safety contacts close and allow the machine start circuit to be enabled. When the solenoid is energised the safety contacts are positively opened and the machine circuit is broken.

Installation:

1. Installation of all IDEM interlock switches must be in accordance with a risk assessment for the individual application. Installation must only be carried out by competent personnel and in accordance with these instructions.
2. M5 (or appropriate) mounting bolts must be used to fix the switch and actuator mounting plates. The tightening torque to ensure reliable fixing is 4.0 Nm. Tightening torque for the lid screws and cable glands must be 1.5 Nm to ensure the IP seal.
3. Always fit a mechanical stop to the guard to prevent damage to the front of the switch. Always ensure correct alignment of actuator and handle with front apertures of the switch and guide. Use alignment guides to ensure that the actuator enters the switch without interfering with the sides of the aperture. Ensure access to at least one of the manual release points. Always fit the aperture plug to the unused entry aperture to prevent debris entering the switch mechanism.
4. After installation check operation of all control circuits and the locking function. For applications with a run down time after removing power, ensure that the correct timing allowance has been made before the solenoid is energised.
5. **IMPORTANT:** At installation choose the status of Contacts 33 and 34 by setting the slide switch inside the switch housing.



If LED2 is used always check for correct .dc polarity.
Contact 33: 0V.dc Contact 34: +24V.dc

Maintenance:

Every week: Check correct operation of all circuits and Lock function. If the actuator show signs of bending or the switch head housing displays mechanical damage then remove and replace.
Every 6 months: Isolate power and remove cover. Check screw terminal tightness and check for signs of moisture ingress. Never attempt to repair any switch.
IDEM will not accept responsibility for failure of the switch functions if the installation and maintenance requirements shown in this sheet are not implemented.

THESE INSTRUCTIONS FORM PART OF THE PRODUCT WARRANTY.

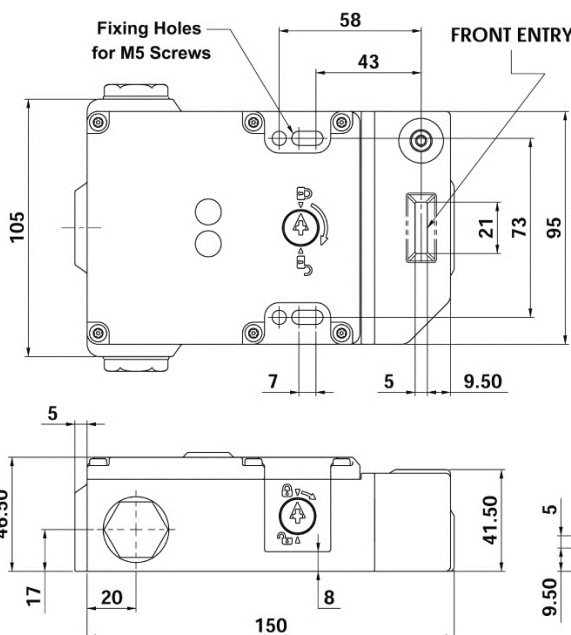

LED Functions:

LED1 Red Solenoid Energised
LED2 (if used) Green Guard Locked

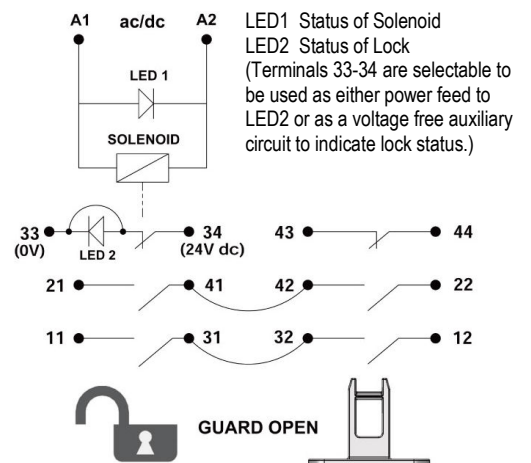

Tongue Switch with Guard Locking

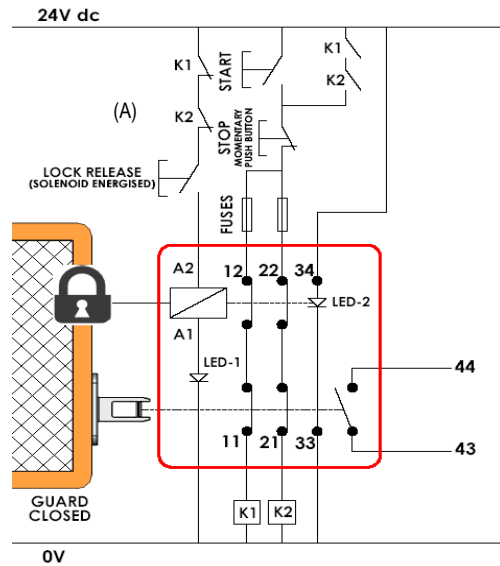

Application Example: Door Interlock with Guard locking - Dual Channel (non-monitored).

The guard is locked closed until the solenoid is energized. The solenoid can only be energized when the auxiliary contacts (A) of contactors K1 and K2 are closed.

When the lock release button is pushed the locking mechanism is released and the switch contacts 11-12 and 21-22 are opened. These contacts are in series with contactor coils of K1 and K2 and will prevent re-start whilst the guard is open.

If after pressing the Stop button either contactor K1 or K2 stays closed the motor will stop but the solenoid cannot be energized or the guard opened.

LED 1 provides visual indication of solenoid power applied.

LED 2 provides visual indication of guard locked and machine able to start.

System is shown with machine stopped, guard closed and locked, and the solenoid able to be energised.

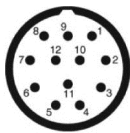

Quick Connect (QC) M23 12 way Male Plug (Pin view from Switch)		Switch Circuit
1	3	A1 A2
4	6	11 / 12
7	8	21 / 22
2	5	43 / 44
9		33
10		34
12		Earth

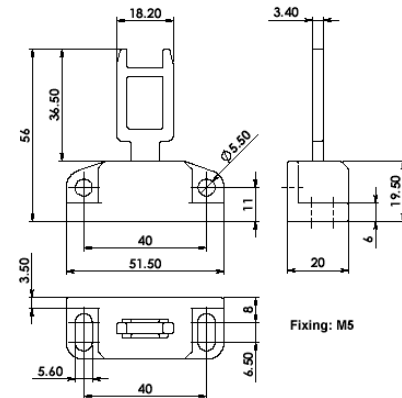
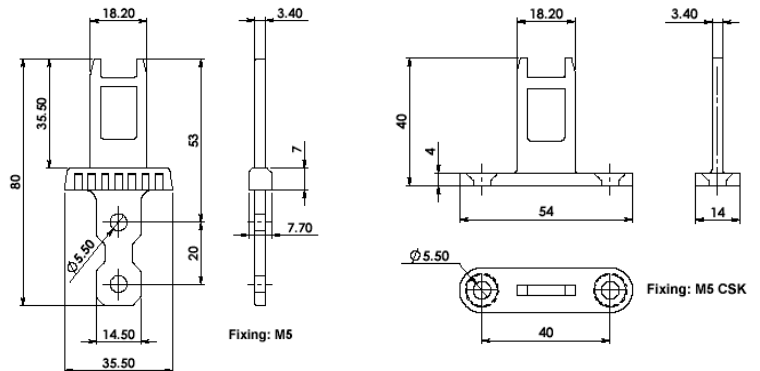

Actuator insertion (mm)

	6.0	5.0	0 mm
11/12	Open		
21/22	Open		
33/34			Open
43/44			Open

Standards: EN1088 EN60947-5-1 EN 60204-1
ISO 13849-1 EN62061 EN 954-1

Safety Classification and Reliability Data:

Mechanical Reliability B10d	2.5 x 10 ⁶ operations at 100mA load up to Category 4 with Safety Relay
EN 954-1	up to PLe depending upon system architecture
ISO 13849-1	up to SIL3 depending upon system architecture
EN 62061	8 cycles per hour / 24 hours per day/365 days
Safety Data - Annual Usage PFHd	3.44 x 10 ⁻⁸
Proof Test Interval (Life) MTTFd	35 years
Supply Voltage	356 years
Power consumption:	24V.dc (+/- 10%)
Safety Circuits:	0.5A. Supply capability 1A.required.
Utilization Category	2NC Positive Break
Thermal Test Current (Ith)	AC15 A300 Maximum Current 3A.
Rated Insulation Voltage	3A
Rated Impulse Withstand Volt	500VAC
Travel for Positive Opening	1000VAC
Man. Actuation Frequency	10mm
Actuator entry minimum radius	2 cycle/sec
Body Case Material	175mm
	KLTM - Die Cast - Painted Red
	KLT-SS - Stainless Steel 316
Head Material	Stainless Steel 316
Mechanical Actuator Material	Stainless Steel 316
Enclosure Protection	KLTM IP67, KLT-SS IP69K
Operating Temperature	-25°C to 40°C
Mechanical Life Expectancy	1 x 10 ⁶ Cycle min.
Vibration	IEC 68-2-6, 10-55Hz+1Hz, Excursion: 0.35mm, 1 octave/min

Information with regard to UL 508:

Type 1 Enclosures.
Intended for same polarity use and one polymeric conduit connection.
Electrical Rating: A300. 48W5.
Max. Switching Current / Volt / Amp:
120V. 6A. (720VA break) PF 0.38
240V. 3A. (720VA break) PF 0.38