

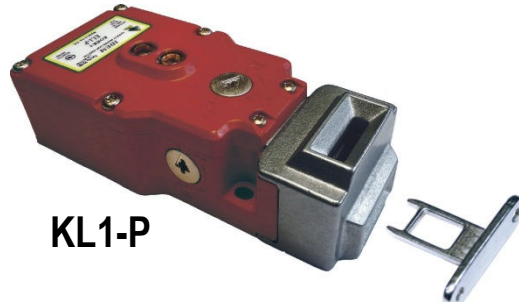

# Safety Interlock Switch with Guard Locking

## KL1-P KL1-SS Operating Instructions



KL1-P



KL1-SS

### IMPORTANT NOTE:

Read and understand these instructions before installing, operating, or maintaining this equipment.

The product is designed to be a component of a customised safety orientated control system. It is the responsibility of each manufacturer to ensure the correct overall functionality of its systems and machines. IDEM, its subsidiaries and affiliates, are not in a position to guarantee all of the characteristics of a given system or product not designed by IDEM.

### Application:

Tongue operated switches are designed to fit to the leading edge of sliding, hinged or lift off machine guards to provide positively operated switching contacts to EN60947-5-1. They are designed to provide robust position interlock detection for moving guards and will remain locked until the solenoid voltage is applied to the switch.

### Operation:

The switch is rigidly mounted to the frame of the guard or machine. The actuator is fitted to the moving part (frame) of the guard and is aligned to the switch entry aperture. The actuator profile is designed to match a cam mechanism within the switch head and provides a positively operated switch. When the actuator is inserted into the switch the safety contacts close and allow the machine start circuit to be enabled. When the solenoid is energised the safety contacts are positively opened and the machine circuit is broken.

### Installation:

- Installation of all switches must be in accordance with a risk assessment for the individual application. Installation must only be carried out by competent personnel and in accordance with these instructions.
- M5 mounting bolts must be used to fix the switch and actuator, the tightening torque to ensure reliable fixing is 4.0 Nm. Tightening torque for the lid screws, conduit entry plugs and cable glands must be 1.0 Nm to ensure IP seal. Only use the correct size gland for the conduit entry and cable outside diameter. Note: For 1/2" NPT versions, the gland thread length must be limited to 10mm maximum. Tightening torque for the connection terminal screws is 0.7 Nm, max conductor size is 1.0 sq.mm. The switch head position can be selected by loosening the 4 head bolts and then rotating to the position required. Tightening torque for the head bolts is 1.5Nm. Always check for correct 24V.dc polarity to LED 2 (if fitted).
- Always fit a mechanical stop to the guard to prevent damage to the front of the switch. Set the actuator gap to 3mm when the guard is closed and against the stop. (See Fig.A). Use alignment guides to ensure that the actuator enters the switch without interfering with the sides of the aperture. Ensure access to at least one of the manual release points. Always fit the aperture plug to the unused entry aperture to prevent foreign debris entering the switch mechanism.
- After installation check operation of all control circuits and the locking function. For applications with a run down time after removing power, ensure that the correct timing allowance has been made before energising the solenoid. For hand operated guards, push to release after solenoid energisation. LED 1 will illuminate when power is applied to A1 and A2 (solenoid feed). LED 2 (if used) will be illuminated when the actuator is not locked. If extinguished then the switch is locked and the safety contacts are closed.

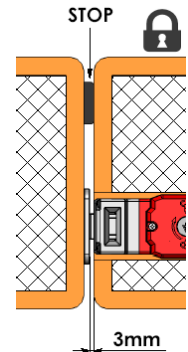

(Fig. A)

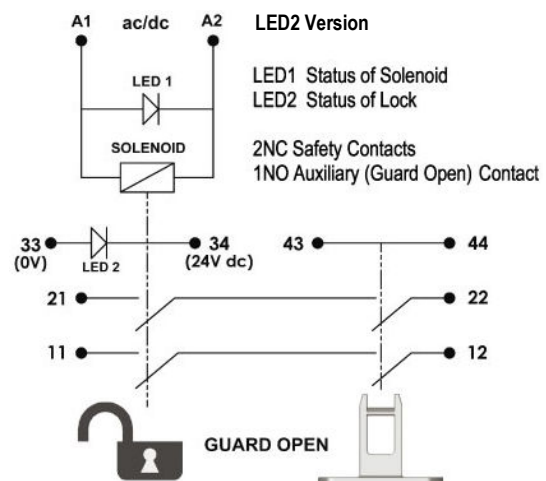
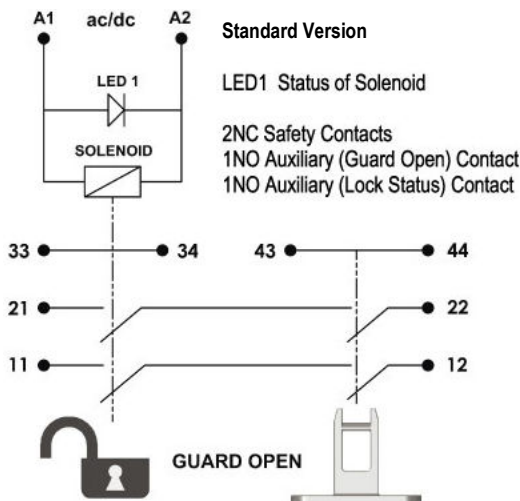

### Maintenance:

Every week: Check correct operation of all circuits and the Lock function. If the actuator shows signs of bending or the switch head housing displays mechanical damage then remove and replace. IDEM will not accept responsibility for failure of the switch functions if the installation and maintenance requirements shown in this sheet are not implemented. These requirements form part of the product warranty.

Every 6 months: Isolate power and remove cover. Check screw terminal tightness and check for signs of moisture ingress. Never attempt to repair any switch.

# Safety Interlock Switch with Guard Locking

## Application Example: Dual Channel non monitored.

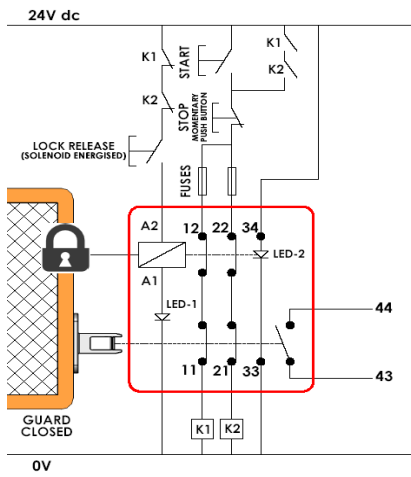

The guard is locked closed until the solenoid is energized. The solenoid can only be energized when the auxiliary contacts (A) of contactors K1 and K2 are closed.

When the lock release button is pushed the locking mechanism is released and the switch contacts 11-12 and 21-22 are opened. These contacts are in series with contactor coils of K1 and K2 and will prevent re-start whilst the guard is open.

If after pressing the Stop button either contactor K1 or K2 stays closed the motor will stop but the solenoid cannot be energized or the guard opened.

LED 1 provides visual indication of solenoid power applied.

LED 2 provides visual indication of guard locked and machine able to start.

System is shown with machine stopped, guard closed and locked, and the solenoid able to be energised.

## Application Example: Dual Channel monitored.

The above system can be enhanced by alternatively connecting the switch circuits 11-12 and 21-22 to an SCR-3 Safety Relay to monitor for wiring short circuits.

This provides Dual Channel monitoring and a check of the contactor feedback circuits through the auxiliary contacts (A) of K1 and K2.

The SCR-3 monitors the switch and the contactors K1 and K2 and provides it's own self-monitoring via force guided internal relays.

System is shown with machine stopped, guard closed and locked, and the solenoid able to be energised.

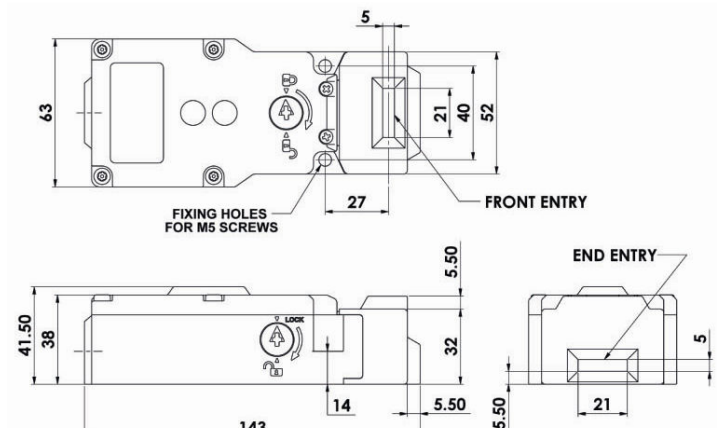
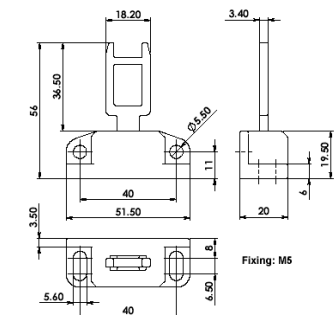
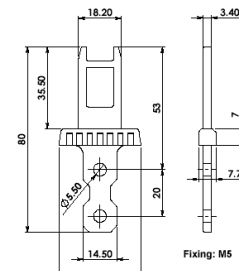
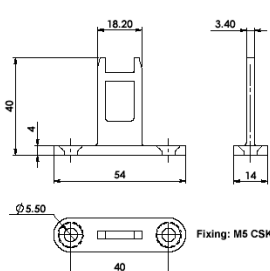
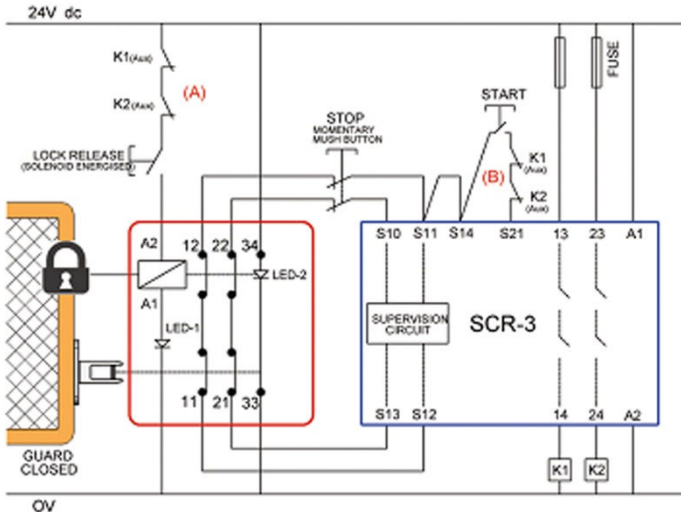

<b>Conforming to Standard:</b>	EN1088, IEC 60947-5-1, UL508
<b>Safety Classification and Reliability Data:</b>	
Mechanical Reliability B10d	2.5 x 10 <sup>6</sup> operations at 100mA load
ISO 13849-1	up to PLe / Cat.4 depending upon system architecture
EN 62061	up to SIL3 depending upon system architecture
Safety Data - Annual Usage	8 cycles per hour / 24 hours per day / 365 days
PFHd	3.44 x 10 <sup>-8</sup>
Proof Test Interval (Life)	35 years
MTTFd	356 years
Solenoid Voltage (by part number)	24V ac/dc or 110V. ac or 230V. ac +/- 10% (12W.)
LED 2 Supply Voltage	24V dc +/- 10%
Safety Contacts 11/12 21/22	Utilization Category AC15 A300 3A.
	Thermal Current (Ith) 5A
Auxiliary Contact 33/34 (selectable with LED2)	230V.ac/dc 0.5A. maximum.
Auxiliary Contact 43/44	230V.ac/dc 0.5A. maximum.
Rated Insulation Voltage	600VAC
Rated Impulse Withstand Volt	2500VAC
Travel for Positive Opening	10mm
Man. Actuation Frequency	2 cycle/sec
Actuator entry minimum radius	175mm Standard 100mm Flexible
Case Material	Glass Filled Polyester or Stainless Steel 316
Actuator Material	Stainless Steel 316
Enclosure Protection	IP67 (Plastic) IP69K (Stainless Steel)
Operating Temperature	-25°C to 55°C
Holding Force	1400N. (Max.)
Vibration	IEC 68-2-6, 10-55Hz+1Hz, Excursion: 0.35mm, 1 octave/min
Conduit Entry	Various (See Sales Part Numbers)
Fixing	4 x M5

**Information with regard to UL 508:**  
 Type 1 Enclosures.  
 Intended for same polarity use and one polymeric conduit connection.  
 Electrical Rating: A300. 48W5.  
 Max. Switching Current / Volt / Amp:  
 120V. 6A. (720VA break) PF 0.38  
 240V. 3A. (720VA break) PF 0.38