

PRODUCT INFORMATION PACKET



Model No: 056B34F5326

Catalog No: D314

General Purpose Motor, 1.50 HP, 1 Ph, 60 Hz, 115/208-230 V, 3600 RPM, 56C Frame, TEFC



Regal and LEESON are trademarks of Regal Rexnord Corporation or one of its affiliated companies.
©2025 Regal Rexnord Corporation, All Rights Reserved. MC017097E





Nameplate Specifications

Phase	1	Output HP	1.50 Hp
Output KW	1.1 kW	Voltage	115/208-230 V
Speed	3450 rpm	Service Factor	1.15
Frame	56C	Enclosure	Totally Enclosed Fan Cooled
Thermal Protection	No Protection	Efficiency	78.5 %
Ambient Temperature	40 °C	Frequency	60 Hz
Current	14.2/7.7-7.1 A	Power Factor	87.5
Duty	Continuous	Insulation Class	B
Design Code	N	KVA Code	H
Drive End Bearing Size	6203	Opp Drive End Bearing Size	6203
UL	Recognized	CSA	Y
CE	Y	IP Code	43
Number of Speeds	1		

Technical Specifications

Electrical Type	Capacitor Start Capacitor Run	Starting Method	Across The Line
Poles	2	Rotation	Selective Counterclockwise
Resistance Main	0 Ohms	Mounting	Bolt-on Base
Motor Orientation	Horizontal	Drive End Bearing	Ball
Opp Drive End Bearing	Ball	Frame Material	Rolled Steel
Shaft Type	NEMA 56	Overall Length	12.82 in
Frame Length	7.56 in	Shaft Diameter	0.625 in
Shaft Extension	2.06 in	Assembly/Box Mounting	F1 ONLY
Outline Drawing	A-100246-756	Connection Drawing	102006-51

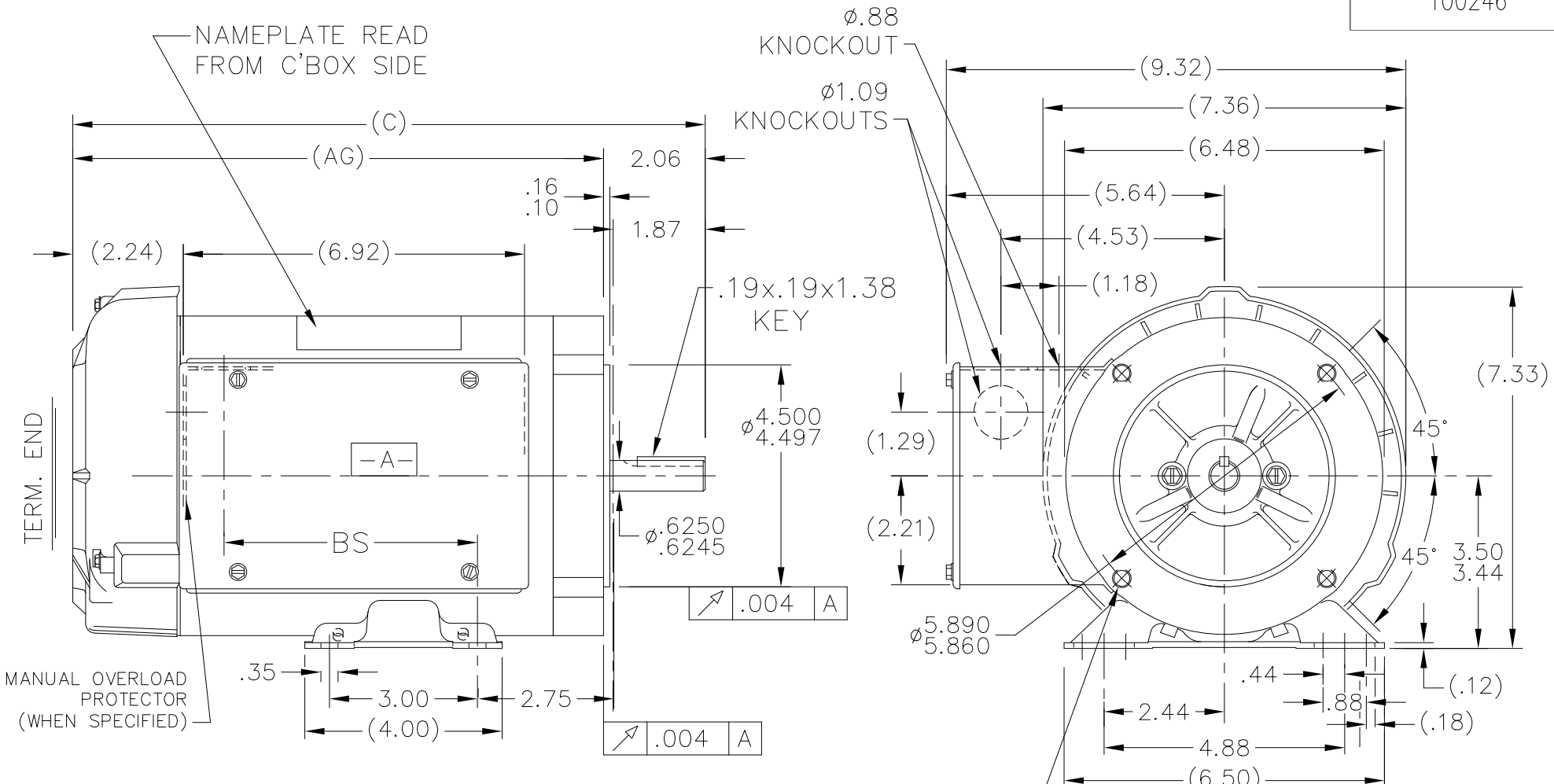

3/8-16 UNC-2B
.56 MIN. FULL THD.
4 HOLES

NOTES:
1. REMOVABLE BASE

DASH	FR.	C	AG	BS
756	56-75	12.82	10.75	5.14
806	56-80	13.32	11.25	5.64
856	56-85	13.82	11.75	6.14
906	56-90	14.32	12.25	6.64
956	56-95	14.82	12.75	7.14

		TOLERANCES UNLESS SPECIFIED		Regal Rexnord Regal Beloit America, Inc.		DRAWN MJD 03-27-1998	
		DEC.	INCHES	TITLE OUTLINE		CHK	ML 04-02-1998
		.X	$\pm .1$	56 FR. - BB - 1° - C'FACE <td>APPD</td> <td>GK 04-02-1998</td>		APPD	GK 04-02-1998
		.XX	$\pm .03$	MAT'L. <td>SCALE</td> <td>5=16</td>		SCALE	5=16
3	CHG FROM MARATHON TO REGAL REXNORD LOGO	KVDG 05-10-2024	DS	.XXX	$\pm .005$	REF	
2	REDRAWN ON CADD	MJD 04-02-1998		.XXXX	$\pm .0005$	FMF	
NO.	REVISION	BY & DATE	CHK	ANG	$\pm 7'30''$	FINISH	PREV
THIS DRAWING IN DESIGN AND DETAIL IS OUR PROPERTY AND MUST NOT BE USED EXCEPT IN CONNECTION WITH OUR WORK ALL RIGHTS OF DESIGN AND INVENTION ARE RESERVED THIS IS AN ELECTRONICALLY GENERATED DOCUMENT - DO NOT SCALE THIS PRINT			RFP	CAD FILE 100246		SIZE	DRAWING NO. PAGE OF REV.
			DIST	WP	A		100246 3 of 7 2

LOW VOLTAGE C.C.W.

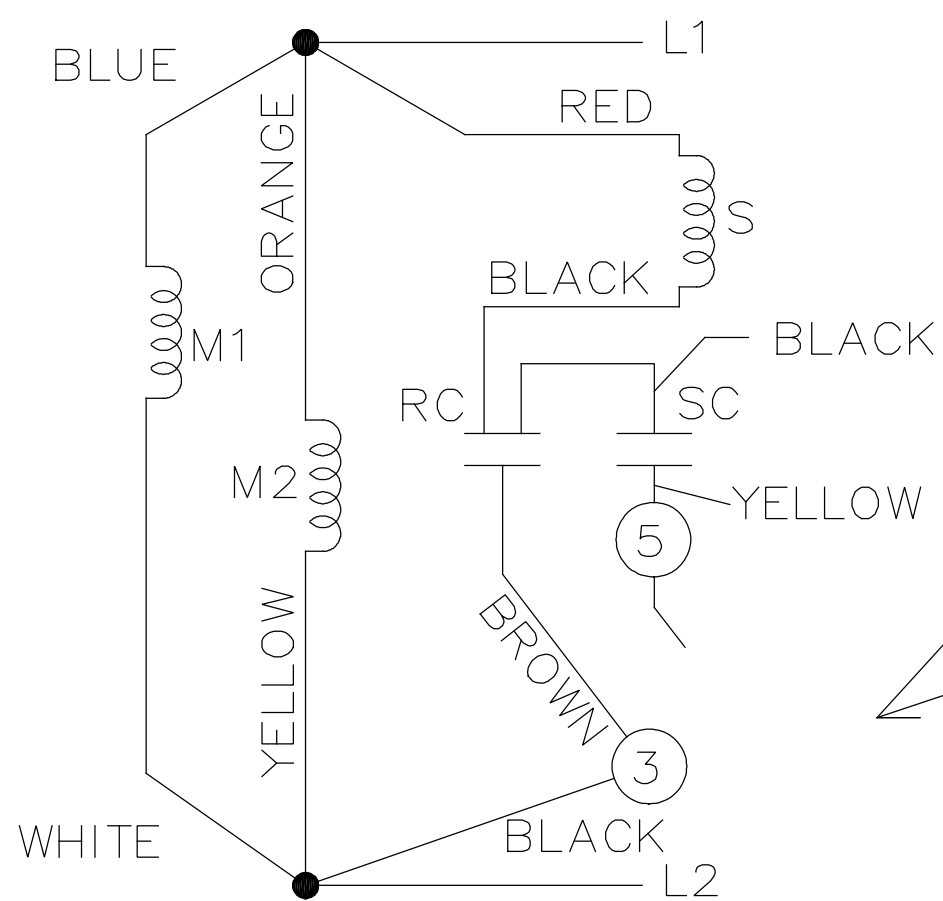

HIGH VOLTAGE C.C.W.

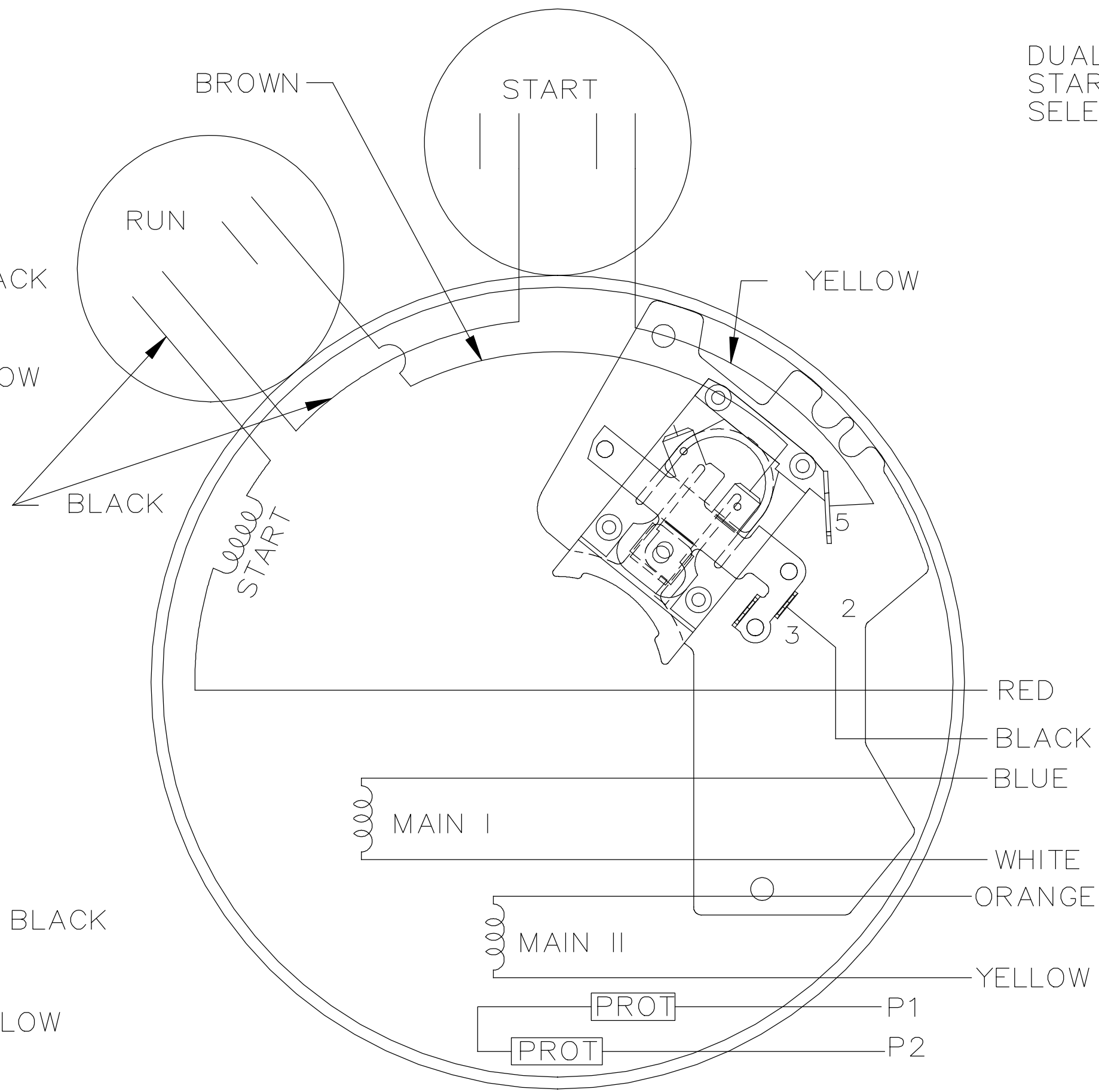
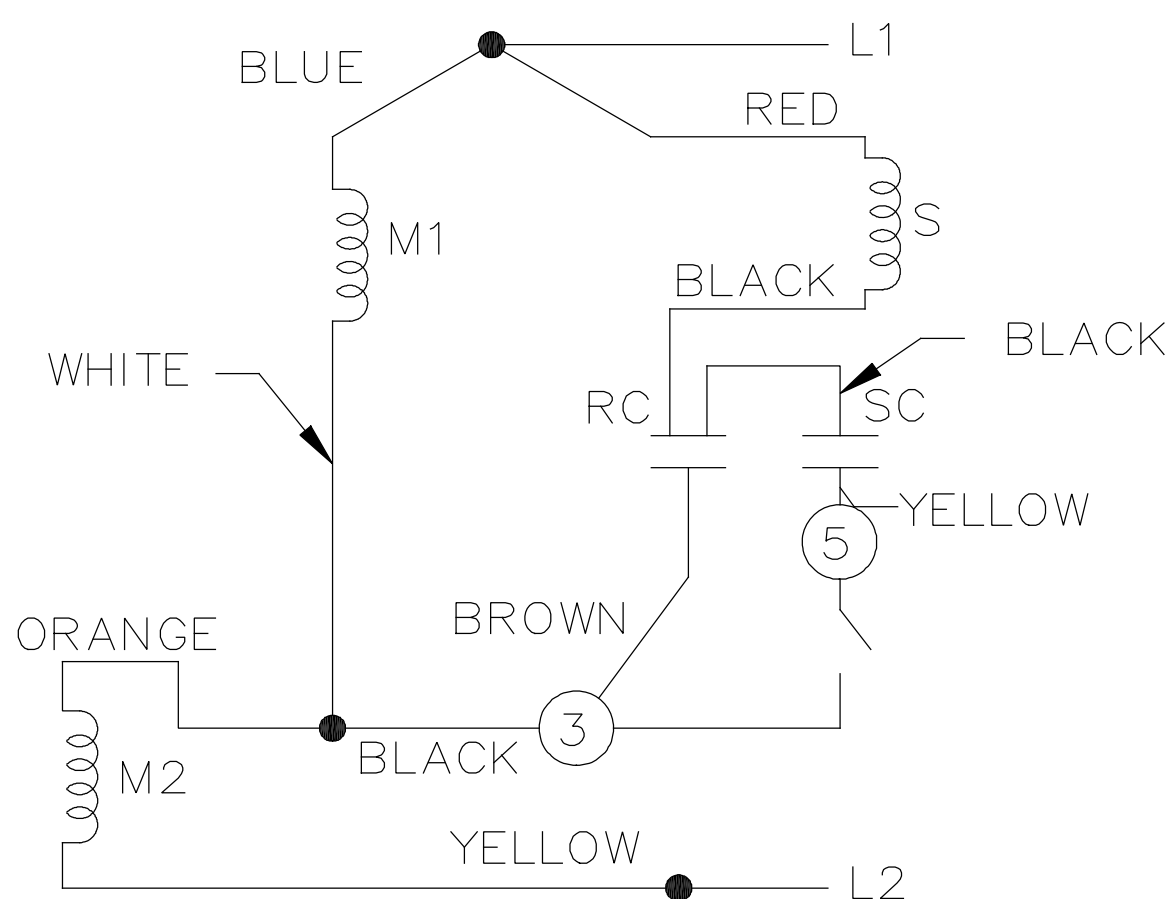

DUAL VOLTAGE CAPACITOR
START-CAP RUN NO OVERLOAD
SELECT ROTATION

LOW VOLTAGE C.C.W. ROTATION

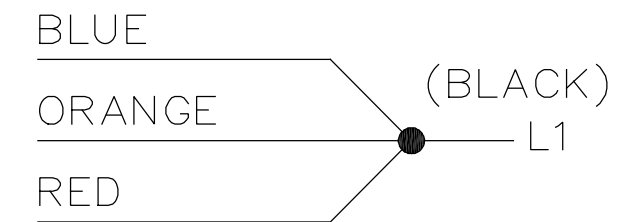

HIGH VOLTAGE C.C.W. ROTATION

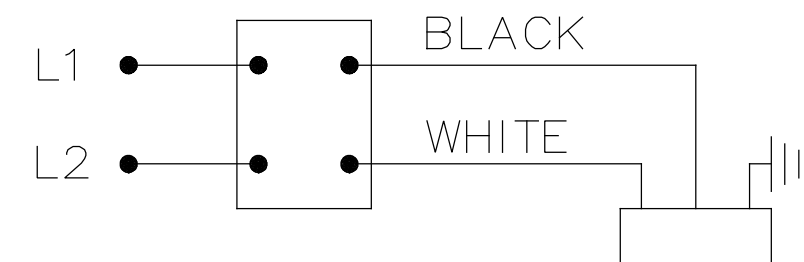
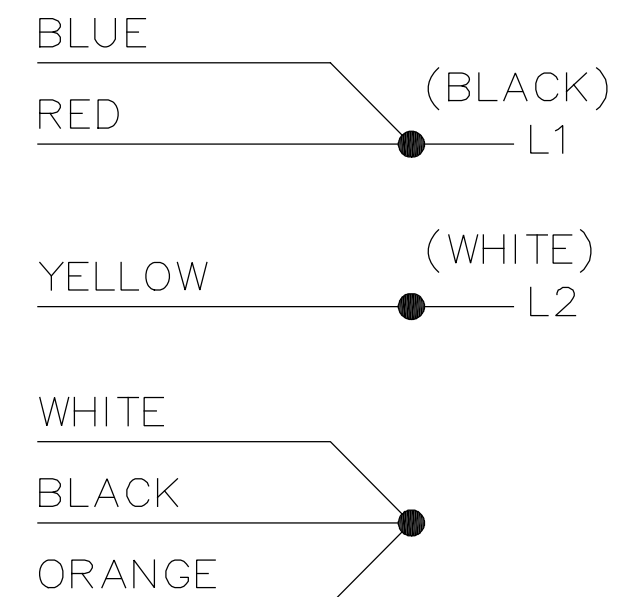

FOR C.W. ROTATION,
EITHER VOLTAGE,
INTERCHANGE RED
WITH BLACK LEAD

		TOLERANCES UNLESS SPECIFIED		 Regal Beloit America, Inc.	DRAWN	SG 05/14/19
		DEC.	INCHES		CHK	CD 05/14/19
		.X	±.1		APPD	CD 05/14/19
		.XX	±.02	TITLE	SCALE	1:1
		.XXX	±.005		REF	102006-51
01	CONVERTED TO DWG FILE	SG	05/14/19	MAT'L.	FMF	PR141156
NO.	REVISION	BY & DATE	CHK	FINISH	PREV	
THIS DRAWING IN DESIGN AND DETAIL IS OUR PROPERTY AND MUST NOT BE USED EXCEPT IN CONNECTION WITH OUR WORK ALL RIGHTS OF DESIGN AND INVENTION ARE RESERVED THIS IS AN ELECTRONICALLY GENERATED DOCUMENT - DO NOT SCALE THIS PRINT				RFP	CAD FILE	102006-51
				DIST	WP	
				SIZE	DRAWING NO.	PAGE OF REV.
				A	102006-51	01

CERTIFICATION DATA SHEET

Model#: 56B34F5326 J
CONN. DIAGRAM: 102006-51
OUTLINE: A-100246-756

WINDING#: ZB216 NONE 3
ASSEMBLY: F1 ONLY

TYPICAL MOTOR PERFORMANCE DATA

HP	KW	SYNC. RPM	F.L. RPM	FRAME	ENCLOSURE	KVA CODE	DESIGN
1 1/2	1.12	3600	3450	56C	TEFC	H	N

PH	Hz	VOLTS	FL AMPS	START TYPE	DUTY	INSL	S.F	AMB°C	ELEVATION
1	60	115/208-230	14.2/7.7-7.1	ACROSS THE LINE	CONTINUOUS	B3	1.15	40	3300

FULL LOAD EFF: 78.5	3/4 LOAD EFF: 72.5	1/2 LOAD EFF: 68	GTD. EFF	ELEC. TYPE	NO LOAD AMPS
FULL LOAD PF: 87.5	3/4 LOAD PF: 85.5	1/2 LOAD PF: 78.5	0	CAP START CAP RUN	5.2 / 2.6

F.L. TORQUE	LOCKED ROTOR AMPS	L.R. TORQUE	B.D. TORQUE	F.L. RISE°C
2.24 LB-FT	96 / 48	5.2 LB-FT 0	6 LB-FT 0	65

SOUND PRESSURE @ 3 FT.	SOUND POWER	ROTOR WK^2	MAX. WK^2	SAFE STALL TIME	STARTS / HOUR	APPROX. MOTOR WGT
0 dBA	10 dBA	0 LB-FT^2	4.2 LB-FT^2	10 SEC.	0	0 LBS.

***** SUPPLEMENTAL INFORMATION *****

DE BRACKET TYPE	ODE BRACKET TYPE	MOUNT TYPE	ORIENTATION	SEVERE DUTY	HAZARDOUS LOCATION	DRIP COVER	SCREENS	PAINT
C-FACE	BRAKE	BOLT-ON	HORIZONTAL	FALSE	NONE	FALSE	NONE	GRAY (POWDER)

BEARINGS		GREASE	SHAFT TYPE	SPECIAL DE	SPECIAL ODE	SHAFT MATERIAL	FRAME MATERIAL
DE	OPE						
BALL	BALL	POLYREX EM	STANDARD 56	NONE	NONE	1144 STRESSPROOF (C-223)	ROLLED STEEL
6203	6203						

THERMO-PROTECTORS				THERMISTORS	CONTROL	SPACE /n HEATERS
THERMOSTATS	PROTECTORS	WDG RTDs	BRG RTDs			
NONE	NOT	NONE	NONE	NONE	FALSE	NONE VOLTS

If Inverter equals NONE, contact factory for further information

*
N
O
T
E
S
*

INVERTER TORQUE: NONE
INV. HP SPEED RANGE: NONE
ENCODER: NONE
NONE NONE
NONE NONE PPR
BRAKE: PROVISIONS FOR KIT NONE
NONE P/N NONE
NONE NONE
NONE FT-LB NONE V NONE Hz

DATE: 06/21/2017 09:23:47 AM
 FORM 3531 REV.3 02/07/99
 ** Subject to change without notice.



REGAL REXNORD CORPORATION
TYPICAL PERFORMANCE CURVE for AC MOTOR

Customer

Curve at

230 Volts
60 HZ
1.5 HP

HP 1.50

PHASE 1

Model No 56B34F5326

VOLTS 115/208-230

Catalog No D314

HZ 60

RPM 3450

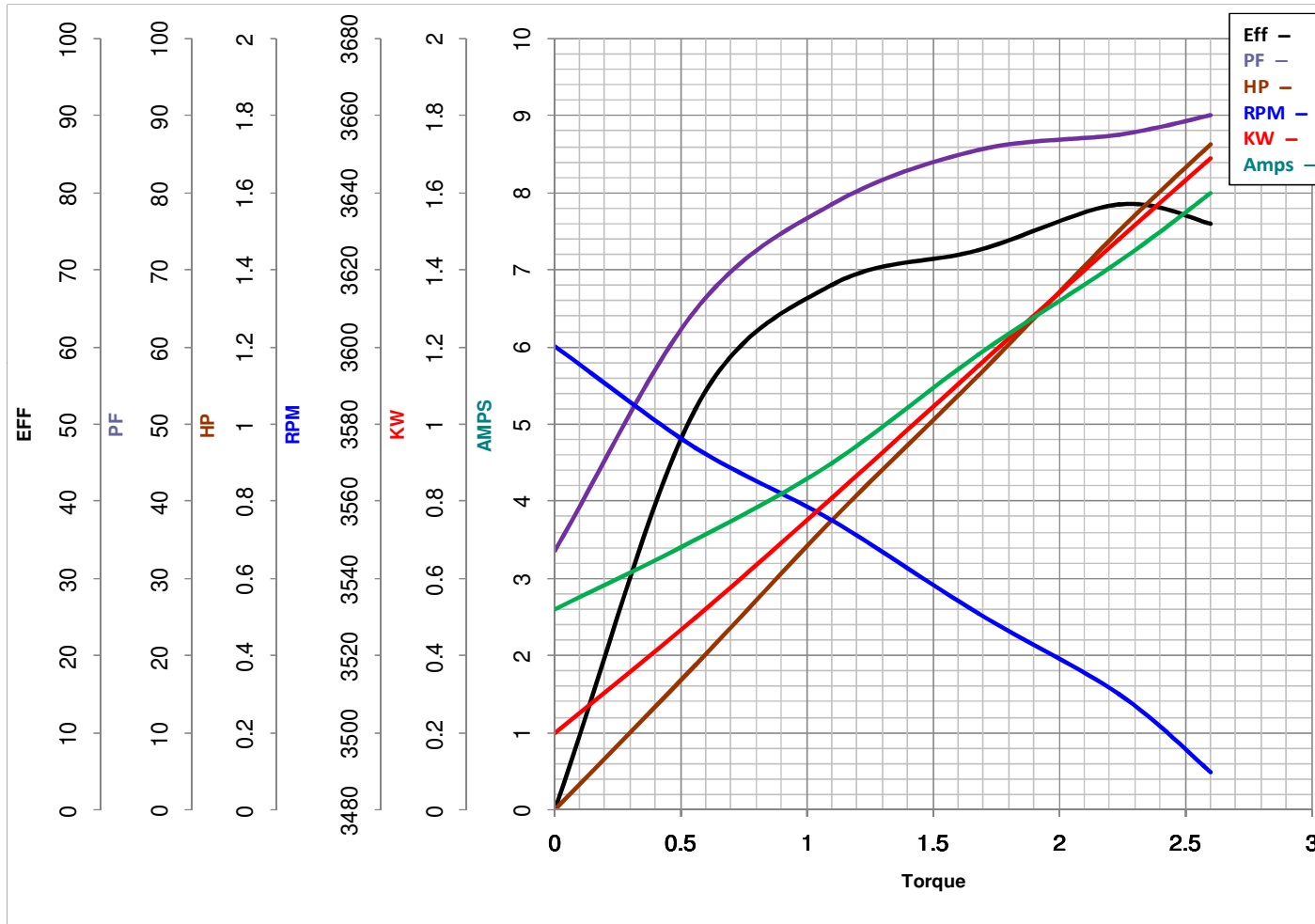

Torque in Lb.Ft

FL TORQUE 2.24 Lb.Ft
BD TORQUE 6.0 Lb.Ft
LR TORQUE 5.2 Lb.Ft

FL AMPS 14.2/7.7-7.1
PU TORQUE 4.8 Lb.Ft
LR AMPS 48

WINDING ZB216-3

Date 1/7/2019

REV 1 - CHANGED LOGO FROM MARATHON TO LEESON - 3/25/2025

EC Declaration of Conformity

The undersigned representing
the manufacturer:

Regal Beloit America
1946 West Cook Road
Fort Wayne, IN 46818

and the authorized representative
established within the Community:

Regal Beloit Italy
Via Modena, 18
24040 Ciserano(BG) - Italy

are committed to providing customers with products that comply with applicable regulations and international protocols to which they are subject, including the requirements of the European Parliament Directive on the Harmonization of the laws relating to electrical equipment designed for use within certain voltage limits (2014/35/EU).

Regal Beloit America declares that the following product(s), to which this declaration relates, are in conformity with the relevant sections of the EC standards listed below.

This statement supersedes any statements previously issued pertaining to the product(s) listed below and is subject to change without notice.

Model No : 056B34F5326

(Model No. may contain prefix and/or suffix characters)

Catalog No : D314

Rework No : N/A

Directives :

Low Voltage Directive 2014/35/EU

Harmonized Standards Used :

EN 60034-1: 2010 (IEC 60034-1: 2010)

EN 60034-5: 2001/A1:2007 (IEC 60034-5: 2000/A1:2006)

Authorized Representative:



Zach Stauffer
Vice President, Engineering

Authorized Representative in the Community:



Stefano Casiraghi
Technology Director, Engineering

Created on 07/08/2025

CE 25