

PROTOS^x

PX-402 – Two-channel 4-20 mA Analog Output Terminal

The PX-402 Analog Output Terminal provides two electrically isolated, 4-20 mA outputs with 12-bit resolution and Run LED status. Use with the Protos XTM I/O System.



Protos XTM is a trademark of Automationdirect.com Incorporated

Sales 800-633-0405

PX-402 Analog Current Output Terminal		
Number of Channels	2	
Output Ranges	4-20 mA	
Resolution	12 bit	
Output Type	Single-ended	
Data Format	Decimal: 0-32767	
Data Bytes Consumed	PX-MOD: 4-bytes output PX-TCP1/TCP2: 8-bytes out/8-bytes in (not used)	
Output Power Source	24VDC via terminal power bus	
Load Consumption (from Power Terminals)	50mA + load	
Source Load	< 500Ω (short-circuit protected)	
Conversion Time	Approx. 1.5ms	
Accuracy	± 0.5 LSB linearity error, ± 0.5 LSB offset error ± 0.1% of the full scale value	
Current Consumption from I/O Bus (5V)	60mA	
Electrical Isolation	500V _{ms} (I/O Bus/signal voltage)	
Heat Dissipation	1W max.	
Adjacent Mounting on Bus Terminals with Power Contact	Yes	
Adjacent Mounting on Bus Terminals without Power Contact	No	
Passes Terminal Bus Power	Yes	
Passes PE Bus	No	
Status Indicators	2, see LED Status chart	
LED Status	On	Off
Green LED: RUN	Normal Operation	Watchdog error if no data transmitted within WD set time.
General Specifications		
Operating Temperature	32° to 131°F (0° to 55°C)	
Storage Temperature	13° to 185°F (-25° to 85°C)	
Relative Humidity	5% to 95%, non-condensing	
Environment Air	No corrosive gases permitted	
Mounting Orientation Restrictions	None	
Vibration	conforms to EN 60068-2-6	
Shock	conforms to EN 60068-2-27, EN 60068-2-29	
Noise Immunity	conforms to EN 61000-6-2/ EN61000-6-4	
Protection Class	IP20	
Weight	80g	
Dimensions (WxHxD)	12 x 100 x 68.8 mm (0.47 x 3.94 x 2.71 in)	
Agency Approvals	UL File No. E157382, CE	

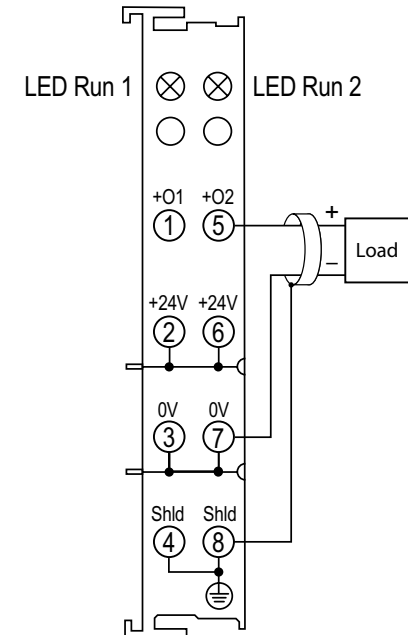
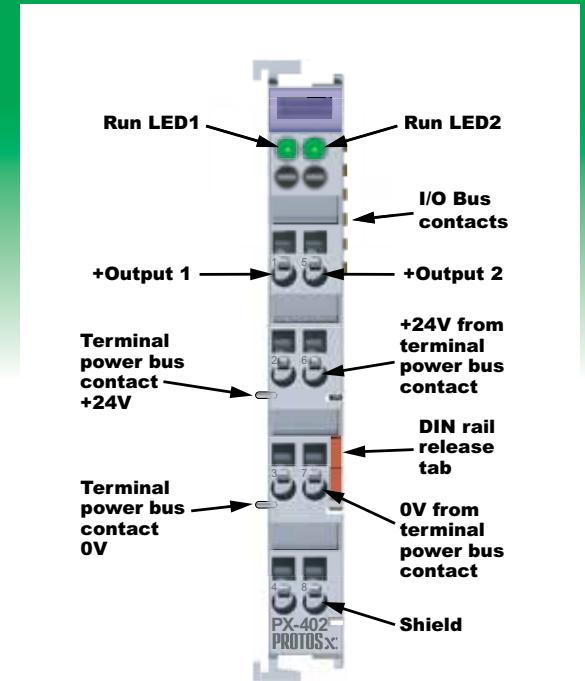

www.automationdirect.com

Tech Support 770-844-4200

MOUNTING

For system assembly, first attach a bus coupler by snapping onto 35mm DIN rail and securing into position using the DIN rail locking wheel (where applicable) located on the left side of the coupler. To add a bus terminal, insert unit onto right side of bus coupler using the tongue and groove at the top and bottom of the unit, pressing gently until it snaps onto the DIN rail. A proper connection cannot be made by sliding the units together on the DIN rail. When correctly installed, no significant gap can be seen between the attached units. Bus connection is made through the six slide contacts located on the upper right side of the units. Add up to 64 bus terminals per bus coupler, including a bus end terminal.

Insert unit using tongue and groove molded guide and press gently until it becomes firmly seated on DIN rail.

Where applicable, rotate Locking Wheel to lock Bus Coupler



REMOVAL

A locking mechanism prevents individual units from being pulled off. For bus terminal removal, pull the orange DIN rail release tab firmly to unlatch the unit from the rail. If attached to other terminal units, slide unit forward until released. For bus couplers with locking wheels, release the DIN rail locking wheel, then pull firmly on DIN rail release tab.

Where applicable, rotate Locking Wheel to unlock Bus Coupler



IMPORTANT

For complete assembly instructions and compatibility between terminals see the PX-USER-M manual available for free download at www.automationdirect.com.

HOT SWAP NOT PERMITTED

Always remove power from the system before inserting or removing bus terminals or couplers as failure to do so could cause malfunction or damage to the terminals, couplers or other connected devices.

Document Name	Edition/Revision	Date
PX-402-DS	1st ED.	9/15/2014

Copyright 2014, AutomationDirect.com Incorporated/All Rights Reserved Worldwide.

WARNING

To minimize the risk of potential safety problems, you should follow all applicable local and national codes that regulate the installation and operation of your equipment. These codes vary from area to area and it is your responsibility to determine which codes should be followed, and to verify that the equipment, installation, and operation are in compliance with the latest revision of these codes.

Equipment damage or serious injury to personnel can result from the failure to follow all applicable codes and standards. We do not guarantee the products described in this publication are suitable for your particular application, nor do we assume any responsibility for your product design, installation, or operation.

If you have any questions concerning the installation or operation of this equipment, or if you need additional information, please call Technical Support at 770-844-4200.

This publication is based on information that was available at the time it was printed. At AutomationDirect.com® we constantly strive to improve our products and services, so we reserve the right to make changes to the products and/or publications at any time without notice and without any obligation. This publication may also discuss features that may not be available in certain revisions of the product.

WIRING CONNECTION

Wire connection is made through a spring clamp style terminal. This terminal is designed for a single-conductor solid or stranded wire. Wire connection is made by firmly pushing the screwdriver into the screwdriver slot, inserting the wire into the wire slot and removing the screwdriver, locking the wire into position.

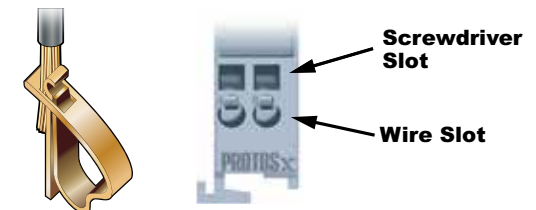

Wiring Specifications

Connection Type	Spring Clamp Terminals
Wire Gauge / Wire Cross Section	28-14 AWG / 0.08 - 2.5mm ²
Screwdriver Width	2.5mm (0.10) such as our TW-SD-MSL-2
Wire Stripping Length	8mm