

# proSense Digital Pressure Switch / Transmitter



AUTOMATIONDIRECT

## Instructions

3505 HUTCHINSON ROAD  
CUMMING, GA 30040-5860

### Models:

- QPSL-AP-42
- QPSL-AN-42
- QPSH-AP-42
- QPSH-AN-42

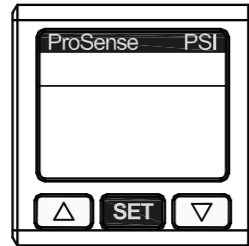

Compact combination Pressure Switch / Transmitter with 2 digital outputs (NPN or PNP) which may be set individually and an analog 4-20mA output. Perfect for the factory floor or installed in a control cabinet. The unit comes with a 2 meter cable for easy installation and has 2 optional mounting brackets available.

### Box Contents and Unpacking Instructions

- Unpack the QPS Pressure Switch from its shipping carton. Included in the carton is the switch, cable and pressure units label and these instructions.
- Inspect all equipment for completeness. If anything is missing or damaged, immediately call the AutomationDirect returns department @ 1-800-633-0405.
- Inspect the part number to ensure the model received matches the output type required.

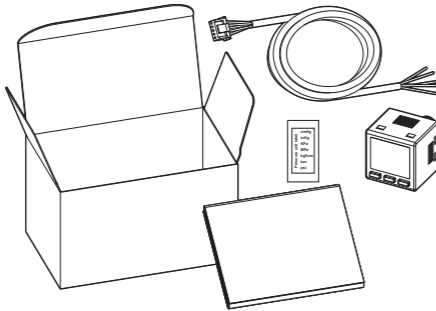

### ProSense QPS Digital Pressure Switch / Transmitter Specifications

Model	QPSL-AP-42	QPSL-AN-42	QPSH-AP-42	QPSH-AN-42
Rated Pressure	-14.5 to +14.5 psi		-14.5 to +145 psi	
Maximum Pressure (Proof)	29psi		217psi	
Maximum Vacuum	-14.5 psi			
Pressure Accuracy	± 3% of full scale			
Temperature Influence @ 25°C	± 2% of full scale			
Fluid Measured	Air, Non-corrosive gas, Non-flammable gas			
Input Power	10.8 to 26.4 VDC			
Power Consumption	260mA maximum			
Digital Outputs	Output Type	2-PNP	2-NPN	2-PNP
	Maximum Current	100mA each		
	Response Time	2ms, 4ms, 10ms, 30ms, 50ms, 100ms, 250ms, 500ms, 1,000ms, 5,000ms selectable		
	Residual Voltage	1.5 VDC		
Analog Output	Output Type	4-20mA		
	Maximum Output Load Resistance	400Ω		
	Linear Accuracy	< ± 2% of full scale		
Process Connection	1/8" NPT outer / M5 inner bore (Nickel Plated Brass)			
Case Materials	Case = ABS Plastic, Lens = Polycarbonate			
Shock Immunity	10 ~ 500 Hz, 10mm 3 axes for 2 hours			
Vibration Immunity	Max. 100m / s <sup>2</sup> 3 axes 6 directions, 3 times each			
Operating Temperature	0°C to +50°C (32°F to 122°F)			
Storage Temperature	-20°C to +65°C (-4°F to 149°F)			
Altitude	< 2,000m			
Ambient Humidity	35% ~ 80% (non-condensing)			
Approvals	cULus - UL 508 (E157382), CE, RoHS			



**WARNING:** To minimize the risk of potential safety problems, you should follow all applicable local and national codes that regulate the installation and operation of your equipment. These codes vary from area to area and it is your responsibility to determine which codes should be followed, and to verify that the equipment, installation, and operation are in compliance with the latest revision of these codes.

Equipment damage or serious injury to personnel can result from the failure to follow all applicable codes and standards. We do not guarantee the products described in this publication are suitable for your particular application, nor do we assume any responsibility for your product design, installation, or operation.

If you have any questions concerning the installation or operation of this equipment, or if you need additional information, please call us at 1-800-633-0405 or 770-844-4200.

This publication is based on information that was available at the time it was printed. At AutomationDirect.com® we constantly strive to improve our products and services, so we reserve the right to make changes to the products and/or publications at any time without notice and without obligation. This publication may also discuss features that may not be available in certain revisions of the product.



### WARNING! Electric shock danger

**ProSense QPS is a pressure measurement device. DO NOT use it out of its specification. Improper pressure or incorrect wiring may cause injuries to staff or damages to other devices.**

1. Keep away from high-voltage and high-frequency environment during the installation to prevent interference. Avoid using the device in environments which contain: (a) dust or corrosive gas; (b) high humidity and high radiation; (c) shock and vibration
2. QPS can only be used for air pressure measurement and should avoid corrosive, inflammable or toxic gas measurement.
3. Make sure the input power is switched off when installing or uninstalling the QPS and the pressure source is off to prevent harm to personnel or equipment.
4. Before switching on the input power, check the signal connection, e.g. the input voltage and polarity. Voltage that is too high may cause damage to the QPS.
5. Use dry cloth and DO NOT use acid or alkaline liquid to clean the device.
6. Outputs remain active in Setup Mode.

### Dimensions

mm [in]

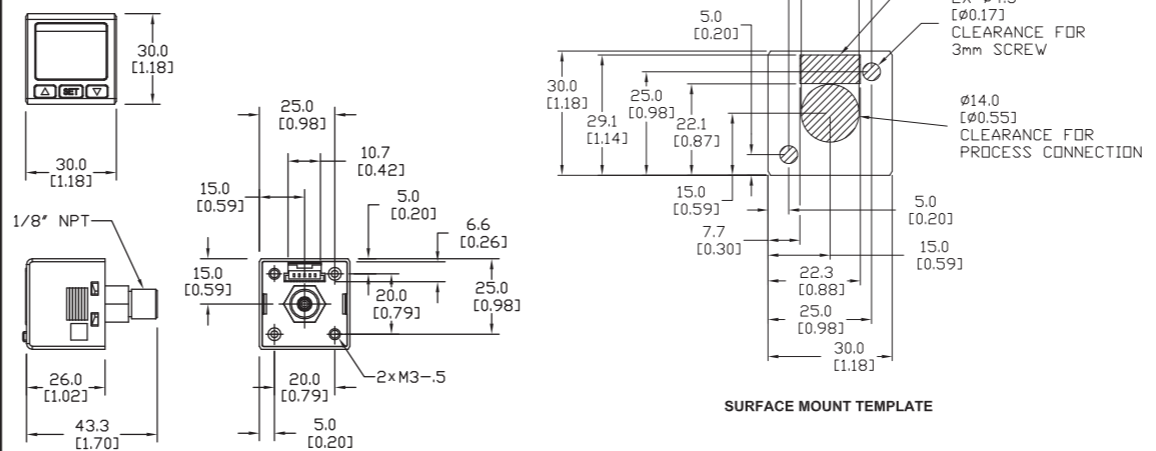

### QPS-PMK - Optional Panel Mount Kit

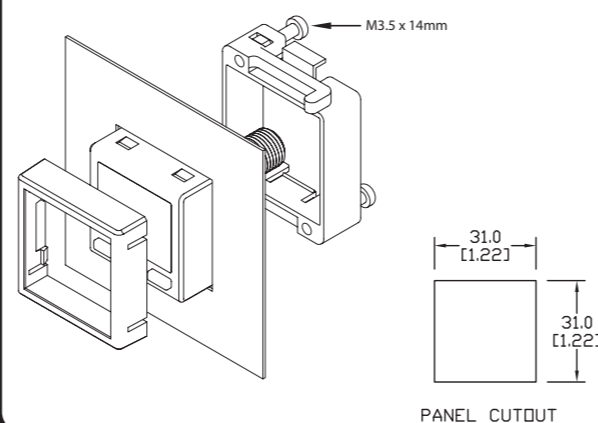

### QPS-FMK - Optional Frame Mount Kit

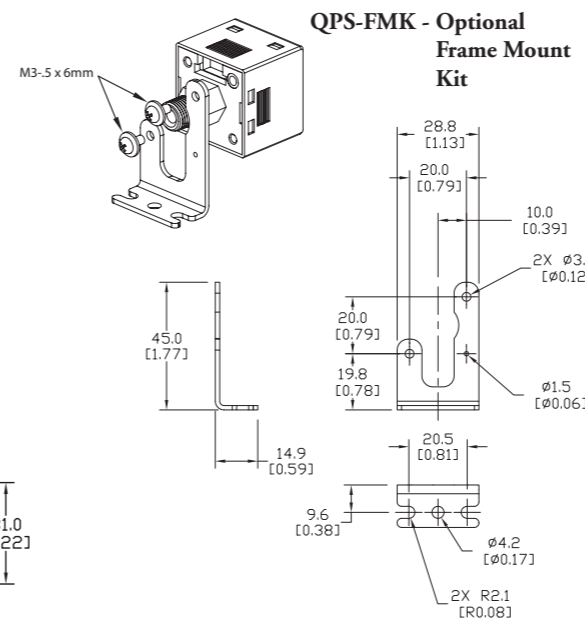

### Wiring

QPSL-AN-42  
QPSH-AN-42  
NPN  
(4-20mA output)

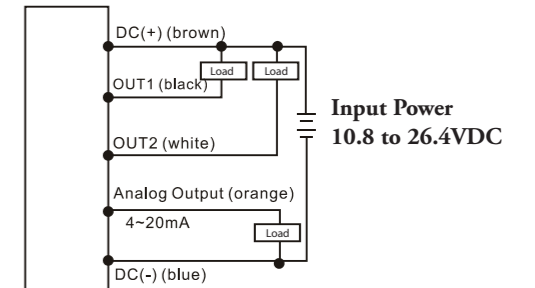

QPSL-AP-42  
QPSH-AP-42  
PNP  
(4-20mA output)

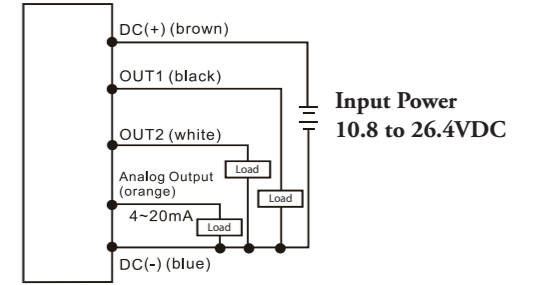

### QPS-CBL (Included with each QPS switch/transmitter)

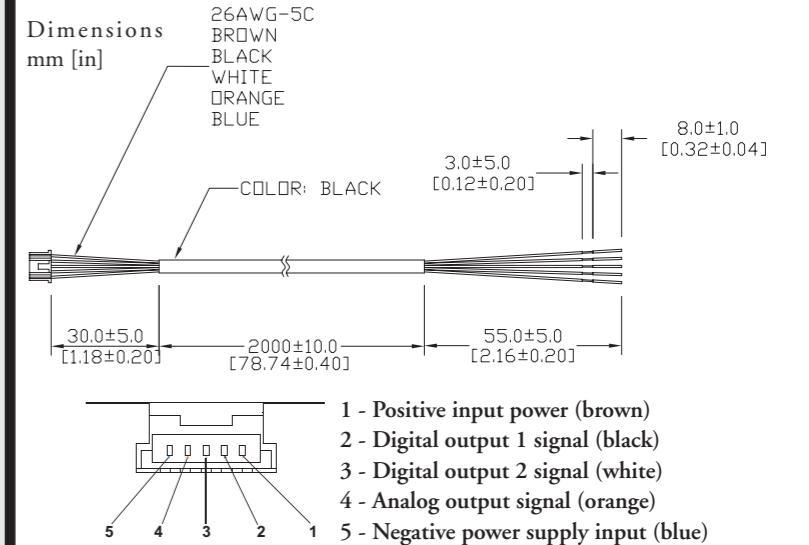

### Display, Keypad and Connections

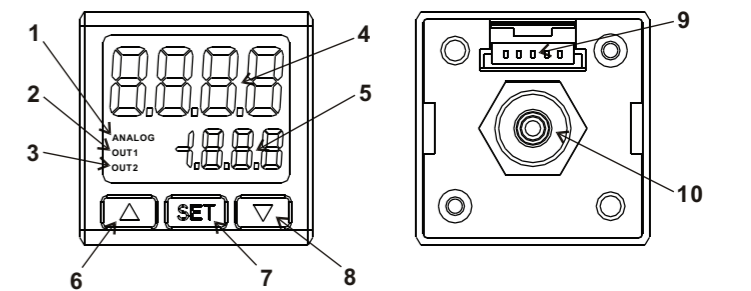

- 1 - Analog output indicator
- 2 - Digital output 1 indicator
- 3 - Digital output 2 indicator
- 4 - Pressure Value (PV)/parameter display (8mm digits)
- 5 - Setpoint Value (SV)/setup item display (4mm digits)
- 6 - Increment UP button
- 7 - SET or Enter button
- 8 - Increment DOWN button
- 9 - Cable connection
- 10 - Pressure connection

## Menu Navigation

### Changing modes:

The QPS will be in the "Run Mode" when it is powered on, displaying PV and SV. Press **SET** for more than 2 seconds in this mode to switch to the "Quick Setup Mode". Press **SET** for more than 4 seconds in the "Run Mode" to switch to "Pro Setup Mode". Press **SET** more than 2 seconds in the "Quick Setup Mode" or "Pro Setup Mode" to return to the "Run Mode".

### Setting up parameters:

In the three modes, press **SET** once to select the parameter to set up. When you find the parameter to set up or modify, use **▲** **▼** to modify the setting.

### Resetting the ProSense QPS to factory default values:

Hold **SET** button for 4-5 seconds until display changes to read **5000**. Press the **SET** button 9 times until the display shows **OFF**.

Using the **▲** **▼** buttons change the value to **0m** and press **SET**.

When complete the display will read **5000**.

Caution: Outputs remain active in Setup Mode

### Accessing QPS Setup Modes:

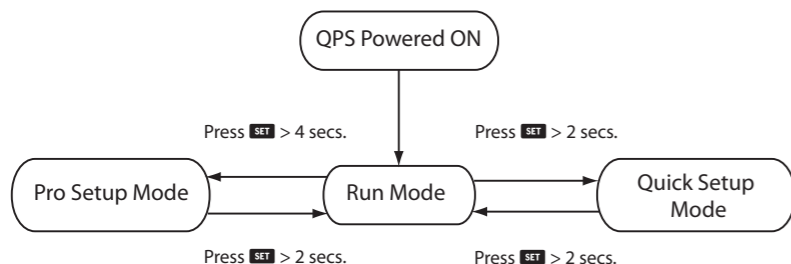

## Quick Setup Mode

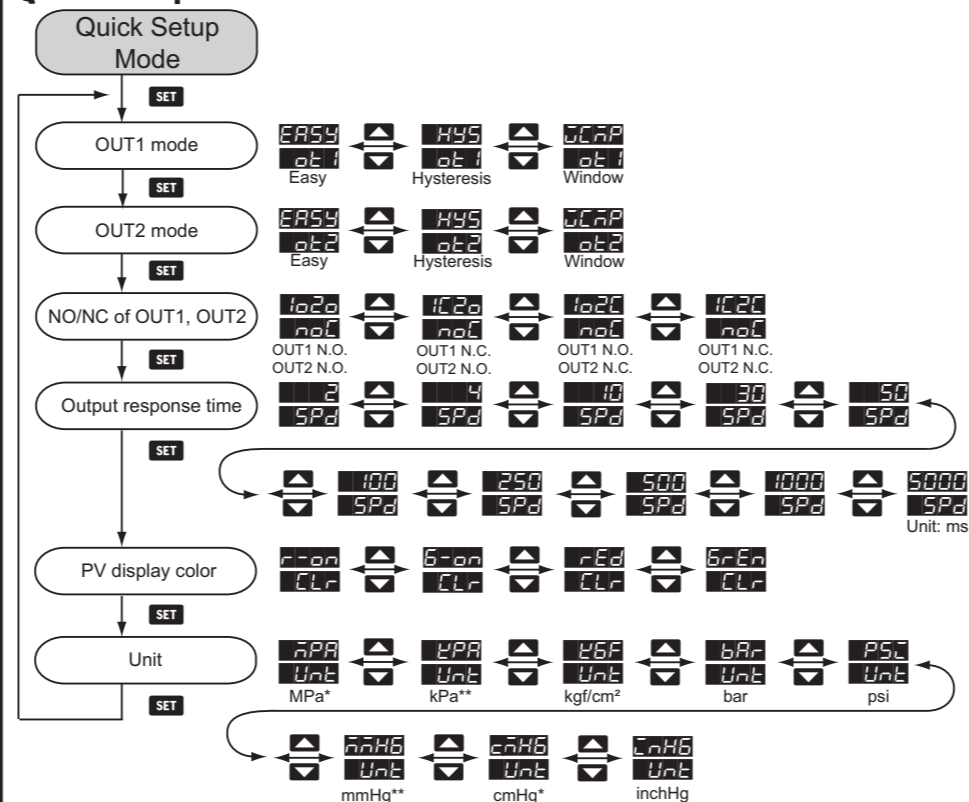

\* Will not be displayed in low pressure type sensor. (QPSL)  
\*\* Will not be displayed in high pressure type sensor. (QPSH)

Quick Setup Mode			
oE1	Mode Selection for Output 1		
oE2	Mode Selection for Output 2		
	EASY Easy Mode (Default) (see examples on Page 4)		
	HYS Hysteresis Mode (see examples on Page 4)		
	WnD Window Mode (see examples on Page 4)		
noC	Normally Open /Normally Closed output selection		
	1o2o Output 1 Normally Open & Output 2 Normally Open (Default)		
	1C2o Output 1 Normally Closed & Output 2 Normally Open		
	1o2C Output 1 Normally Open & Output 2 Normally Closed		
	1C2C Output 1 Normally Closed & Output 2 Normally Closed		
SPd	Output Response Time in milli-seconds - use to minimize digital output fluctuations due to pressure variations (Default = 2)		
CLr	Color - set how display color will change based on parameter dPY in Pro Setup Mode		
	r-on PV display turns red based on output status as set by parameter dPY in Pro Setup Mode (Default)		
	b-on PV display turns green based on output status as set by parameter dPY in Pro Setup Mode		
	rEd PV display is always red regardless of Out1 and/or Out2 state		
	bREn PV display is always green regardless of Out1 and/or Out2 state		
UnE	Select Engineering Units		
	Engineering Units	Display Resolution	
		QPSH	
		QPSL	
	MPa available only on QPSH-Ax-42	0.001	-
	kPa- available only on QPSL-Ax-42	-	0.1
	kgf/cm²	0.01	0.001
	bar	0.01	0.001
	psi (Default)	0.1	0.01
	mm Hg available only on QPSL-Ax-42	-	1
	cm Hg available only on QPSH-Ax-42	1	-
	inch Hg	1	0.1

## Additional Help and Support

• For additional technical support and questions, call our Technical Support team @ 1-800-633-0405 or 770-844-4200



## Pro Setup Mode

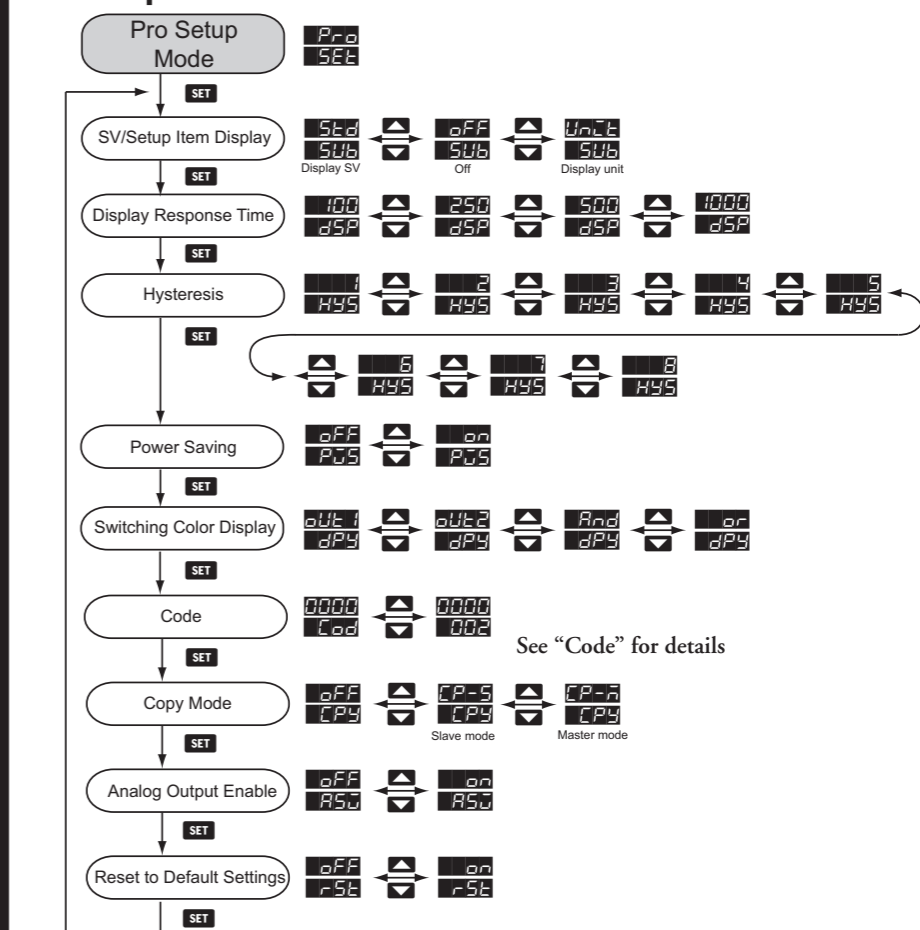

Pro Setup Mode		
Pro	Pro Setup Mode - Displays when entering Pro Setup Mode	
SEt	Setup - Displays when entering Pro Setup Mode	
Sub	SV / Setup Item Display selection	
	50b Display shows SV (Default)	
	off OFF	
	50B Display shows Engineering unit, set by UnE in Quick Setup Mode	
dSP	Display response time rate in milli-seconds (Default = 100)	
HYS	Hysteresis setting for outputs in EASY and WINDOW modes (Default = 3), applies to both outputs	
	QPSH	QPSL
	MPa (MPa) 1 = 0.001 MPa thru 8 = 0.008 MPa	-
	kPa (kPa) -	1 = 0.1 kPa thru 8 = 0.8 kPa
	kgf/cm² (kgf/cm²) 1 = 0.01 kgf/cm² thru 8 = 0.08 kgf/cm²	1 = 0.001 kgf/cm² thru 8 = 0.008 kgf/cm²
	bar (bar) 1 = 0.01 bar thru 8 = 0.08 bar	1 = 0.001 bar thru 8 = 0.008 bar
	psi (psi) 1 = 0.1 psi thru 8 = 0.8 psi	1 = 0.01 psi thru 8 = 0.08 psi
	mm Hg (mmHg) -	1 = 1 mm Hg thru 8 = 8 mm Hg
	cm Hg (cmHg) 1 = 1 cm Hg thru 8 = 8 cm Hg	-
	In Hg (InHg) 1 = 1 in Hg thru 8 = 8 in Hg	1 = 0.1 in Hg thru 8 = 0.8 in Hg
POs	Power Saving Mode - Turns display back light off. Display values can be viewed momentarily by pressing the SET button	
dPY	Switching color display - sets when display changes colors (as set by parameter CLr) based on output status	
	oU1 Color changes when Output 1 is ON (Default)	
	oU2 Color changes when Output 2 is ON	
	Rnd Color changes when Output 1 and Output 2 are ON	
	on Color changes when Output 1 or Output 2 is ON	
CoD	Code - quick reference to determine the settings of the QPS device (See Code Reference Table - Page 3)	
CPY	Copy - used to select master and slave when copying settings to other QPS devices	
	CP-S Copy Slave Mode	
	CP-M Copy Master Mode	
ASO	Analog Output Enable (Default = ON)	
rSE	Reset QPS to Factory Defaults	

## CODE (Pro Setup Mode Parameter )

CODE provides a quick method to determine the settings of the QPS parameters (Factory Default  

Code	1 <sup>st</sup> digit		2 <sup>nd</sup> digit		3 <sup>rd</sup> digit	4 <sup>th</sup> digit	
	OUT1 mode	N.O./N.C.	OUT2 mode	N.O./N.C.	Output Response Time	Color	Switching Color Display
0	Easy	N.O.	Easy	N.O.	2ms	Red when ON	OUT1
1		N.C.		N.C.	4ms		OUT2
2	Hysteresis	N.O.	Hysteresis	N.O.	10ms		OUT1 and OUT2
3		N.C.		N.C.	30ms		OUT1 or OUT2
4	Window	N.O.	Window	N.O.	50ms	Green when ON	OUT1
5		N.C.		N.C.	100ms		OUT2
6	-	-	-	-	250ms		OUT1 and OUT2
7	-	-	-	-	500ms		OUT1 or OUT2
8	-	-	-	-	1,000ms	Red	OUT1
9	-	-	-	-	-		OUT2
A	-	-	-	-	-		OUT1 and OUT2
b	-	-	-	-	-	Red	OUT1 or OUT2
c	-	-	-	-	-		OUT1
d	-	-	-	-	-	Green	OUT2
e	-	-	-	-	-		OUT1 and OUT2
F	-	-	-	-	-		OUT1 or OUT2

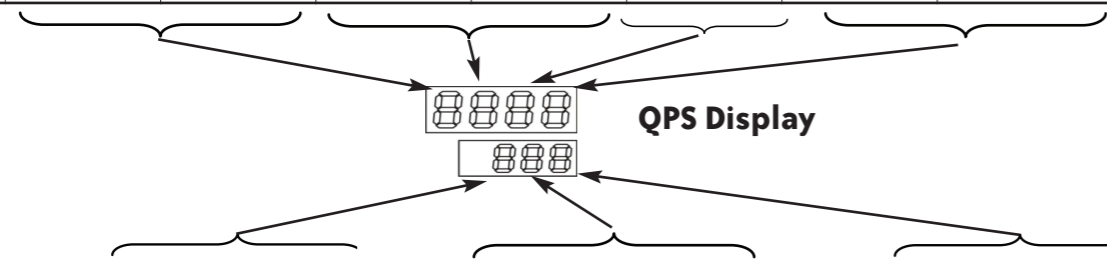

Code	6 <sup>th</sup> digit	7 <sup>th</sup> digit		8 <sup>th</sup> digit
	Pressure Unit	Display Response Time	SV/Setup Item Display	Hysteresis Setting
0	kPa or MPa	100ms	Standard	1
1	kgf/cm <sup>2</sup>		Off	2
2	bar		Unit	3
3	psi	250ms	Standard	4
4	mm Hg or cm Hg		Off	5
5	inch Hg		Unit	6
6	-	500ms	Standard	7
7	-		Off	8
8	-		Unit	-
9	-	1,000ms	Standard	-
A	-		Off	-
b	-		Unit	-

## Analog Output

The analog output is directly proportional to the process pressure over the full range of the device. For example if the process pressure is 0 psi the 4-20 mA output of a QPSL will be approximately 12 mA or for the QPSH the pressure at 12 mA would be 65.3 psi and for 0 psi the output would be 5.45 mA. The analog output is enabled as the factory default. It can be disabled with the "Analog Output Enable" parameter in Pro Setup Mode.

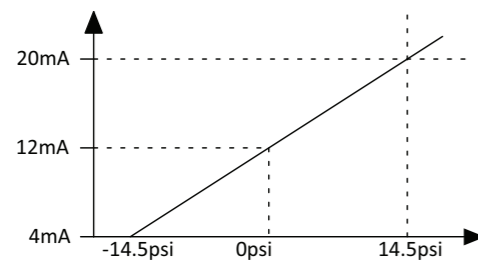

QPSL-xx-42

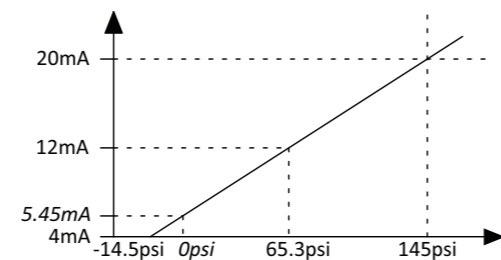







QPSH-xx-42





## QPS is able to copy the parameters from one device to another.

Electrical connection for copying parameters:



Connect Pin 2 (black) on master to Pin 3 (white) on slave; Pin 3 (white) on master to Pin 2 (black) on slave; Pin 5 (blue) on master and slave to COM on power supply; Pin 1 (brown) on master and slave to +24V on power supply.

Setup for copying parameters:

**Slave device:** In the "Run Mode", press  for more than 4 seconds and release the key after you see . You are now in "Pro Setup Mode". Press  7 times and find the parameter for setting up the copy function (See Pro Setup Mode chart). Use   to select  (CP-S refers to Copy-Slave).

**Master device:** In the "Run Mode", press  for more than 2 seconds and release the key after you see . You are now in the "Pro Setup Mode". Press 7 times and find the parameter for setting up the copy function (See Pro Setup Mode chart). Use   to select  (CP-M refers to the Copy-Master).



Next, press  for more than 2 seconds and return to the "Run Mode".



Now you will see  on the display and  on the slave device, indicating that the two devices have been connected. In the lower display  you will see numbers counting up, referring to the number of parameters transmitted successfully between the two devices.

Once the copy of parameters completes, you will see  on the master device and  on the slave device.

After the copy is complete, power the units off and re-connect them according to the wiring diagram.

## Locking the Keys



**Lock On:** Press  and  together for 2 seconds until  is displayed. You will then see the display of pressure value (PV) and setpoint value (SV).

**Lock Off:** Press  and  together for 2 seconds until  is displayed. You will then see the display of pressure value (PV) and setpoint value (SV).

**Lock Display:** Press any key in the key locking mode, and you will see the display of pressure value (PV) and  (SV). Release the key and the PV and SV will return to original values.

## Resetting Zero Pressure:

Remove pressure from device before starting.

In the "Run Mode", press   simultaneously, and you will see . The zeroing will start. Release the keys to end the zeroing sequence.

## Process Connection

Use a suitable thread sealant Teflon® tape. Do not use liquid thread sealant. Always tighten with an open end or adjustable wrench on the wrench flats. Never use any part of the pressure gauge to tighten other than the wrench flats that are on the gauge socket. Failure to do so will severely damage the pressure gauge.

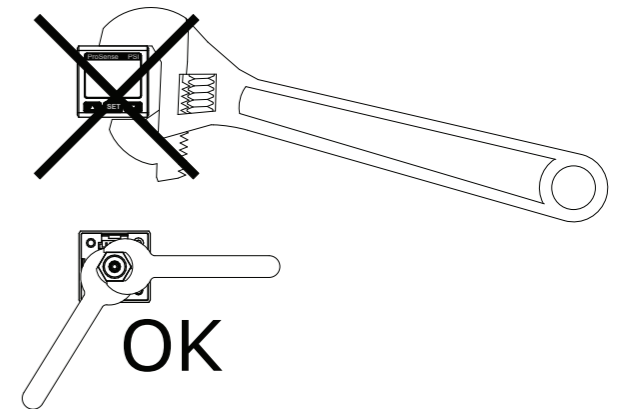

**Easy Mode:** When the measured pressure is greater than pressure setpoint plus the hysteresis setting (SV+hysteresis), the output will change state. When the measured pressure is less than the pressure setpoint (<SV), the output will change state. Each digital output can be individually set.

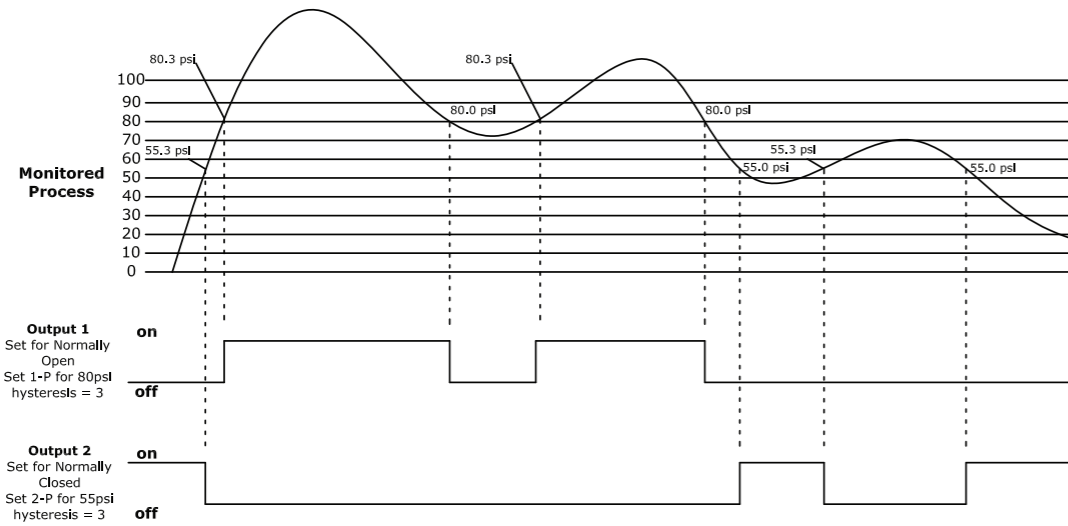

**Using EASY Mode to Set up a Simple Alarm**

Hold **SET** button for 2-3 seconds until display changes.  
 Verify **DE1** is set to **ERSS**, if not use the **▼▲** to change and press **SET** button.  
 Verify **DE2** is set to **ERSS**, if not use the **▼▲** to change and press **SET** button.  
 Verify **noC** is set to **1020**, if not use the **▼▲** to change and press **SET** button.  
 Press and hold the **SET** button until the display changes to show the Setpoint and Process values.  
 Using the **▼▲** set the output 1 ON level for **1-P** to 80psi.  
 Briefly press and release the **SET** button to change to **2-P** and set the output 2 ON level to 55psi.  
 Hold **SET** button for 4-5 seconds until display changes to **Prd**.  
 Press the **SET** button 3 times so that **HYS** is on the display.  
 Verify the value 3 is in the lower display, if not use the **▼▲** to change and press **SET** button  
 Press and hold the **SET** button until the display changes to show the Setpoint and Pressure copy values.

**Window Mode:** In the example below the output will change state when the measured pressure increases to 55.3psi (**1-L 50 + HYS**) and will change state again when the pressure increases to 90.3psi (**1-H 50 + HYS**). As the measured pressure decreases back to 90psi (**1-H 50**) the output will change state and will change state again when the pressure decreases to 55psi (**1-L 50**). Each digital output can be individually set.

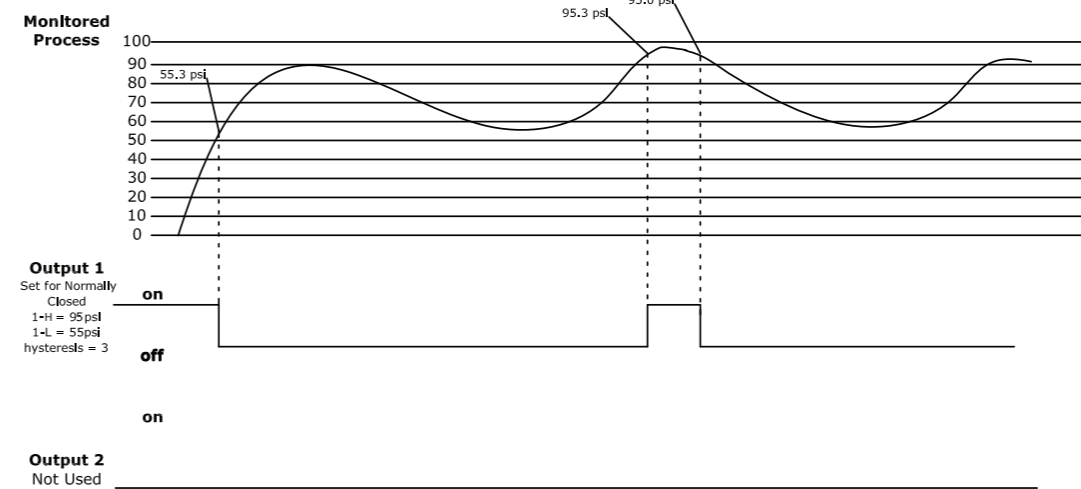

**Using Window Mode to create alarm condition**

Hold **SET** button for 2-3 seconds until display changes.  
 Verify **DE1** is set to **CCCP**, if not use the **▼▲** to change and press **SET** button.  
 Verify **DE2** is set to **ERSS**, if not use the **▼▲** to change and press **SET** button.  
 Verify **noC** is set to **1020**, if not use the **▼▲** to change and press **SET** button.  
 Press and hold the **SET** button until the display changes to show the Setpoint and Process values.  
 Using the **▼▲** set the output 1 **1-H** level to 95psi.  
 Briefly press and release the **SET** button to change to **1-L** and set it to 55psi.  
 Hold **SET** button for 4-5 seconds until display changes to **Prd**.  
 Press the **SET** button 3 times so that **HYS** is on the display.  
 Verify the value 3 is in the lower display, if not use the **▼▲** to change and press **SET** button  
 Press and hold the **SET** button until the display changes to show the Setpoint and Process values.

**Hysteresis Mode:** When the measured pressure is greater than the Hi setpoint, the output will change state. When the measured pressure is less than the Lo setpoint, the output will change state. Each digital output can be individually set.

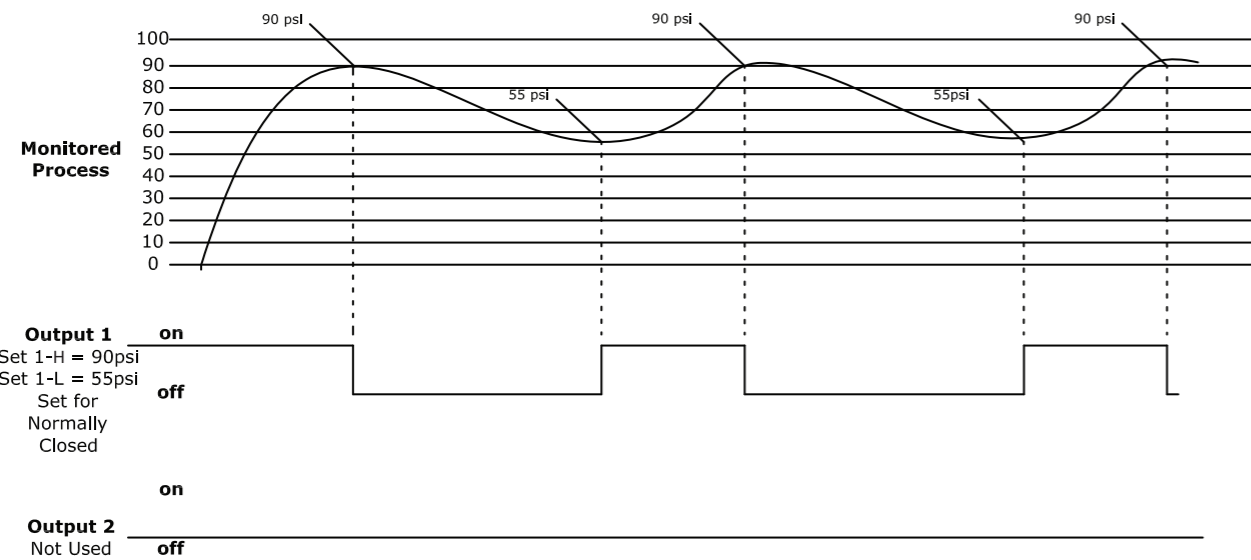

**Using Hysteresis Mode to control the pressure in a tank**

Hold **SET** button for 2-3 seconds until display changes.  
 Verify **DE1** is set to **HYS**, if not use the **▼▲** to change and press **SET** button.  
 Verify **DE2** is set to **ERSS**, if not use the **▼▲** to change and press **SET** button.  
 Verify **noC** is set to **1020**, if not use the **▼▲** to change and press **SET** button.  
 Press and hold the **SET** button until the display changes to show the Setpoint and Process values.  
 Using the **▼▲** set the output 1 **1-H** level to 90psi.  
 Briefly press and release the **SET** button to change to **1-L** and set it to 55psi.

**Hysteresis & Window Modes of operation for control and alarming**

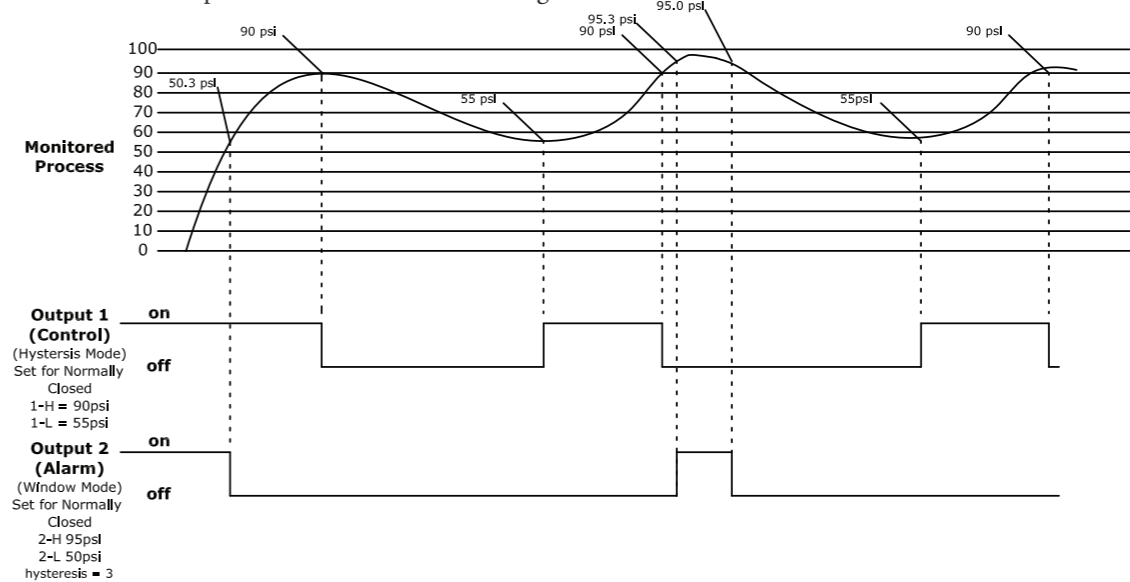

**Using Hysteresis mode to control the pressure in a tank and window mode to generate an alarm**

Wire the QPS using the connection diagrams supplied.  
 Hold **SET** button for 2-3 seconds until display changes.  
 Verify **DE1** is set to **HYS**, if not use the **▼▲** to change and press button.  
 Verify **DE2** is set to **CCCP**, if not use the **▼▲** to change and press button.  
 Verify **noC** is set to **1020**, if not use the **▼▲** to change and press button.  
 Press and hold the **SET** button until the display changes to show the Setpoint and Process values.  
 Using the **▼▲** set the output 1 **1-H** level to 90psi.  
 Briefly press and release the **SET** button to change to **1-L** and set it to 55psi.  
 Briefly press and release the **SET** button to change to **2-H** and set it to 95psi.  
 Briefly press and release the **SET** button to change to **2-L** and set it to 50psi.  
 Hold **SET** button for 4-5 seconds until display changes to **Prd**.  
 Press the **SET** button 3 times so that **HYS** is on the display.  
 Verify the value 3 is in the lower display, if not use the **▼▲** to change and press **SET** button.  
 Press and hold the **SET** button until the display changes to show the Setpoint and Process values.

**Hysteresis** is defined as: The lag in response of the output in reacting to changes in the process affecting it. For example Setpoint 1-P is set to 80 PSI for output 1 but the output does not change state when the pressure is increasing until the actual pressure reaches 80.3 PSI (1-P+hysteresis), the output will then change back to its neutral state once the pressure drops below the Setpoint of 80 PSI. This function known as Hysteresis is used to prevent the outputs from chattering if the process pressure were to hover close to the Setpoint.