

# proense®



Operating instructions  
Magnetic-inductive flow meter

**FMM50-1002**

**FMM75-1002**

**FMM100-1002**

80229911 / 00 07 / 2015

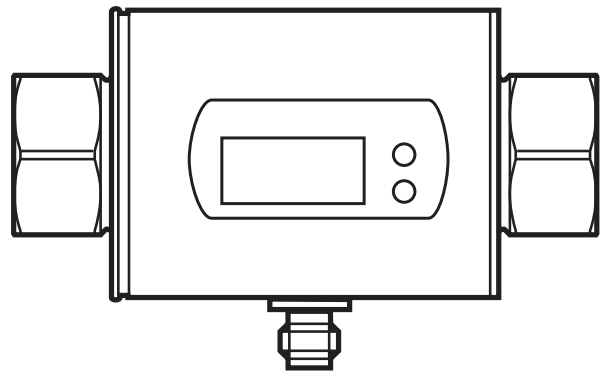

by [Automationdirect.com](http://Automationdirect.com)

# Contents

1 Preliminary note.....	4
1.1 Symbols used .....	4
1.2 Warning signs used .....	4
2 Safety instructions .....	4
3 Functions and features .....	5
4 Function .....	6
4.1 Measuring principle for flow rate monitoring.....	6
4.2 Processing of the measured signals.....	6
4.3 Flow rate measurement.....	7
4.4 Temperature monitoring.....	7
4.5 Flow rate or temperature monitoring / analog function .....	8
5 Installation.....	9
5.1 Recommended installation locations .....	9
5.2 Not recommended installation position.....	10
5.3 Grounding .....	11
6 Electrical connection.....	11
7 Operating and display elements .....	12
8 Menu.....	13
8.1 Menu structure.....	13
8.2 Explanation of the menu .....	14
9 Set-up .....	15
10 Parameter setting .....	15
10.1 Parameter setting in general .....	16
10.1.1 Switching between the menu levels .....	16
10.1.2 Locking / unlocking .....	17
10.1.3 Timeout.....	17
10.2 Setting the analog value for temperature .....	17
10.3 Setting the analog value for flow rate .....	17

10.4	User settings (optional).....	17
10.4.1	Setting of the standard unit of measurement for temperature .....	17
10.4.2	Setting of the standard unit of measurement for flow rate.....	17
10.4.3	Configuration of the standard display .....	18
10.4.4	Setting of measured value damping .....	18
10.4.5	Setting of the error behaviour of the outputs .....	18
10.5	Service functions .....	18
10.5.1	Reading the min/max values for the flow rate .....	18
10.5.2	Reading the min/max values for the temperature.....	19
10.5.3	Resetting all parameters to factory setting .....	19
11	Operation .....	19
11.1	Reading the process value .....	19
11.2	Reading the parameter value.....	20
11.3	Error indications .....	20
12	Technical data.....	21
13	Factory setting .....	21

# 1 Preliminary note

## 1.1 Symbols used

- ▶ Instruction
- > Reaction, result
- [...] Designation of keys, buttons or indications
- Cross-reference



Important note

Non-compliance can result in malfunction or interference.



Information

Supplementary note.

## 1.2 Warning signs used



### CAUTION

Warning of personal injury.

Injuries may result.

## 2 Safety instructions

- Please read this document prior to set-up of the unit. Ensure that the product is suitable for your application without any restrictions.
- If the operating instructions or the technical data are not adhered to, personal injury and/or damage to property can occur.
- Improper or non-intended use may lead to malfunctions of the unit or to unwanted effects in your application. That is why installation, electrical connection, set-up, operation and maintenance of the unit must only be carried out by qualified personnel authorized by the machine operator.
- In order to guarantee the correct condition of the device for the operating time the device must only be used in media to which the wetted parts are sufficiently resistant ( → Technical data).
- The responsibility to determine whether the measurement devices are suitable for the respective application lies with the operator. The manufacturer assumes no liability for consequences of misuse by the operator. Improper installation and use of the devices result in a loss of the warranty claims.

- For medium temperatures above 122 °F some parts of the housing can heat up to over 149 °F. Moreover, during installation or in case of a fault (e.g. housing damage) media under high pressure or hot media can leak from the system. To avoid personal injury, take the following measures:
  - ▶ Install the unit according to the applicable rules and regulations.
  - ▶ Ensure that the system is free of pressure during installation.
  - ▶ Protect the housing against contact with flammable substances and unintentional contact. To do so, equip the unit with suitable protection (e.g. protective cover).
  - ▶ Do not press the pushbuttons manually; instead use another object (e.g. ballpoint pen).

### 3 Functions and features

The unit monitors liquid media.

The unit detects the 2 process categories flow rate and medium temperature.



Pressure Equipment Directive (PED):

The units comply with the Pressure Equipment Directive and are designed and manufactured for group 2 fluids in accordance with sound engineering practice. Use of group 1 fluids on request.

#### Application area

Conductive liquids with the following properties:

- Conductivity:  $\geq 20 \mu\text{S}/\text{cm}$
- Viscosity:  $< 70 \text{ cST}$  at 40°C / 104°F

## 4 Function

### 4.1 Measuring principle for flow rate monitoring

The magnetic-inductive measuring principle means that a magnetic field is generated in the measuring pipe via current-carrying coils. When a conductive medium flows through the measuring pipe, the ions therein are diverted perpendicularly to the magnetic field. Positive and negative charge carriers flow in opposite directions. The voltage induced is measured by two electrodes that are in contact with the medium. This signal voltage is directly proportional to the average flow velocity. The flow rate is derived from the internal pipe diameter.

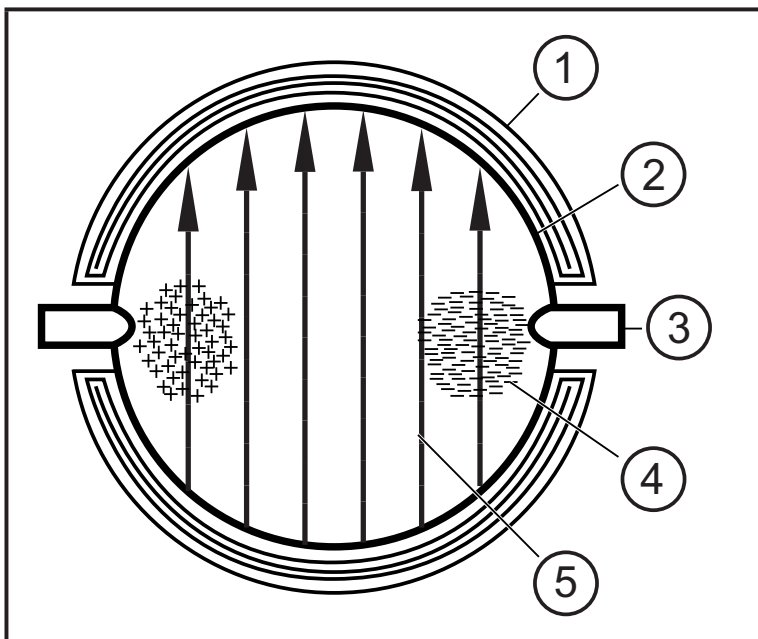

- 1: Field coil
- 2: Measuring pipe
- 3: Electrode
- 4: Charge carrier in the medium
- 5: Magnetic field



Both electrodes must be in contact with the medium.

### 4.2 Processing of the measured signals

The unit displays the current process values.

It generates 2 output signals according to the parameter setting.

OUT1:

- Analog signal for temperature

Parameter setting

(→ 10.2)

OUT2:

- Analog signal for flow rate

Parameter setting

(→ 10.3)

### 4.3 Flow rate measurement

An analog signal which is proportional to the flow rate (4...20 mA) is provided on output 2 in case of medium flow in the measuring pipe. (On the analog functions → 4.5)

In addition to the flow rate, the unit also detects the flow direction. An arrow on the unit indicates the positive flow direction.

Direction of flow corresponds to "flow direction"

> process value and display positive.

Direction of flow against "flow direction"

> process value and display negative.



Only positive process values are processed for the signal output.

### 4.4 Temperature monitoring

An analog signal (4...20 mA) can be provided on output 1 for temperature monitoring. (On the analog functions → 4.5)

## 4.5 Flow rate or temperature monitoring / analog function

### Current output

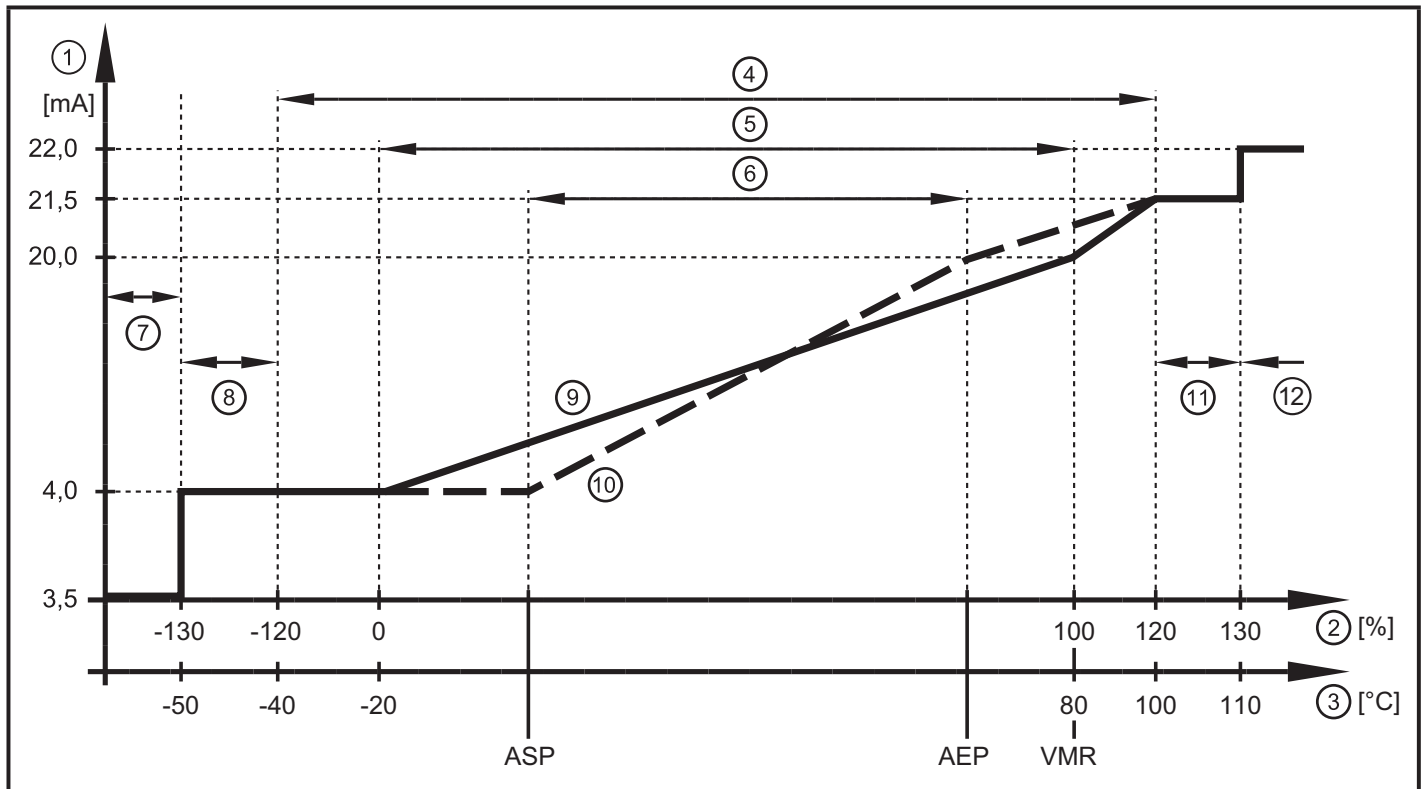

Characteristics of the analog output according to the standard IEC 60947-5-7

- 1: Output current
- 2: Flow rate
- 3: Temperature
- 4: Display range
- 5: Measuring range
- 6: Range between analog start point and analog end point
- 7: The unit is in the error state (FOU = OFF)
- 8: The process value transmitted in an analog way is therefore below the display range
- 9: Curve of the analog signal at factory setting
- 10: Curve of the analog signal with shifted ASP and AEP
- 11: The process value transmitted in an analog way is therefore above the display range
- 12: The unit is in the error state (FOU = ON).

ASP = analog start point: determines at which measured value the output signal is 4 mA.  
AEP = analog end point: determines at which measured value the output signal is 20 mA.  
VMR = final value of the measuring range = 100 %



Minimum distance between ASP and AEP = 20 % of the measuring range.

In the set scaling range the output signal is between 4 and 20 mA.



## 5 Installation



- ▶ Avoid deposits, accumulated gas and air in the pipe system.

### 5.1 Recommended installation locations

Example of an optimized installation:

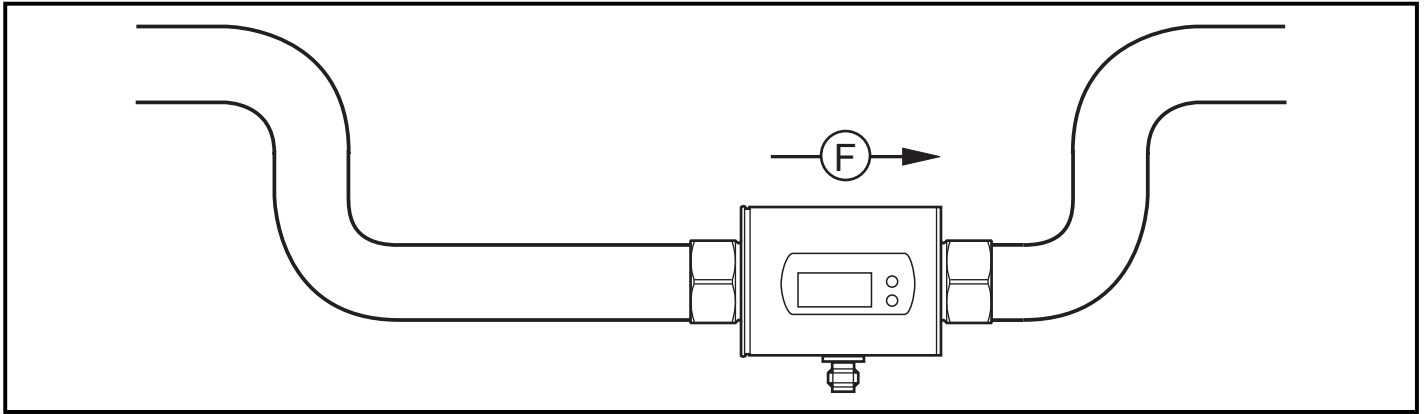

- ▶ Install the unit so that the measuring pipe is completely filled.
- ▶ Arrange for inlet and outlet pipe lengths. Disturbances caused by bends, valves, reductions, etc. are compensated for. It applies in particular: no shut-off and control devices are allowed directly in front of the unit.

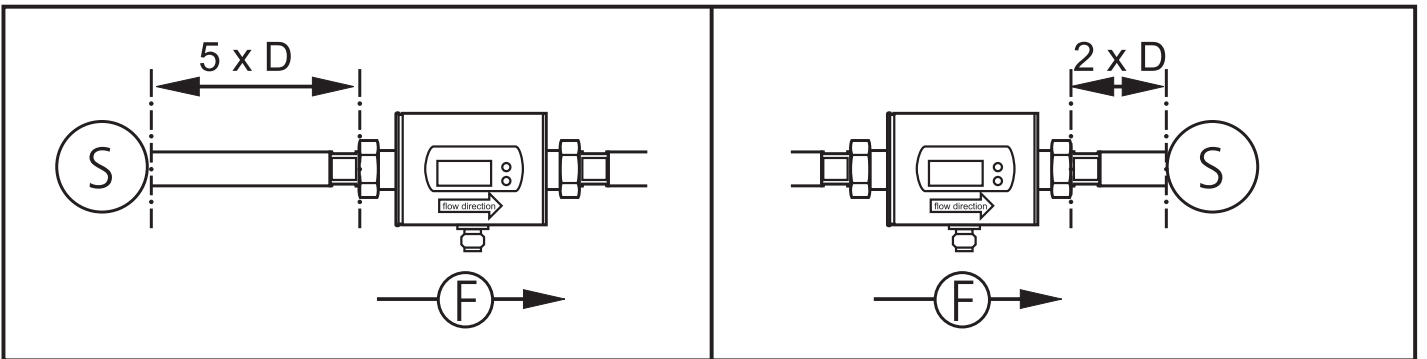

- ▶ Install in front of or in a rising pipe.

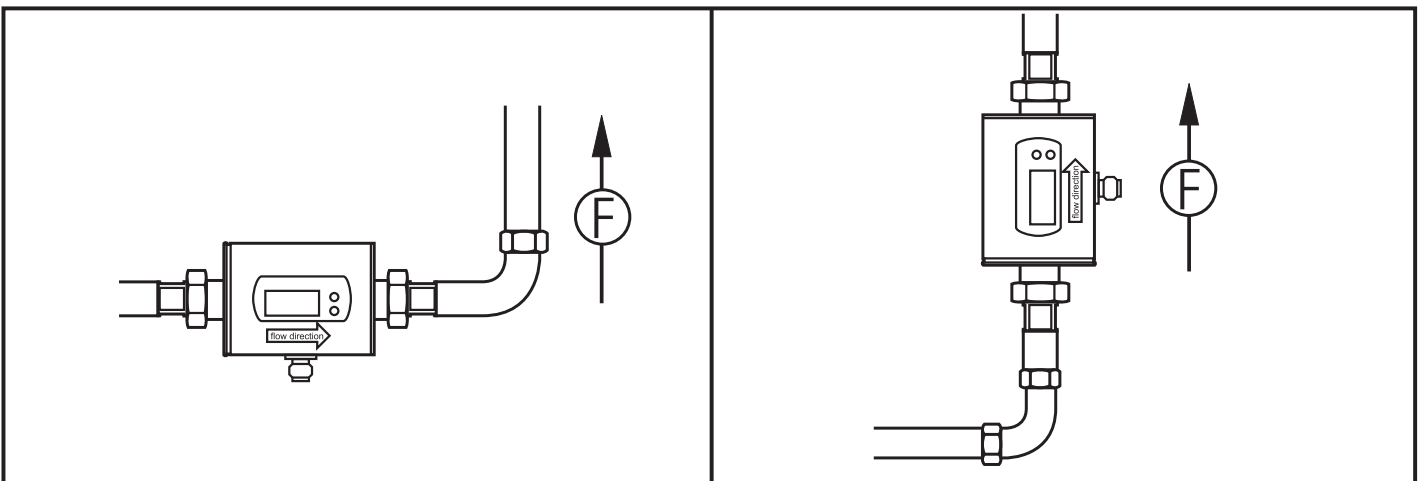

S = disturbance; D = pipe diameter; F = flow direction



The unit can be installed irrespective of the orientation if the following is ensured:

- No air bubbles can form in the pipe system.
- The pipes are always completely filled.

## 5.2 Not recommended installation position

► Avoid the following installation positions:

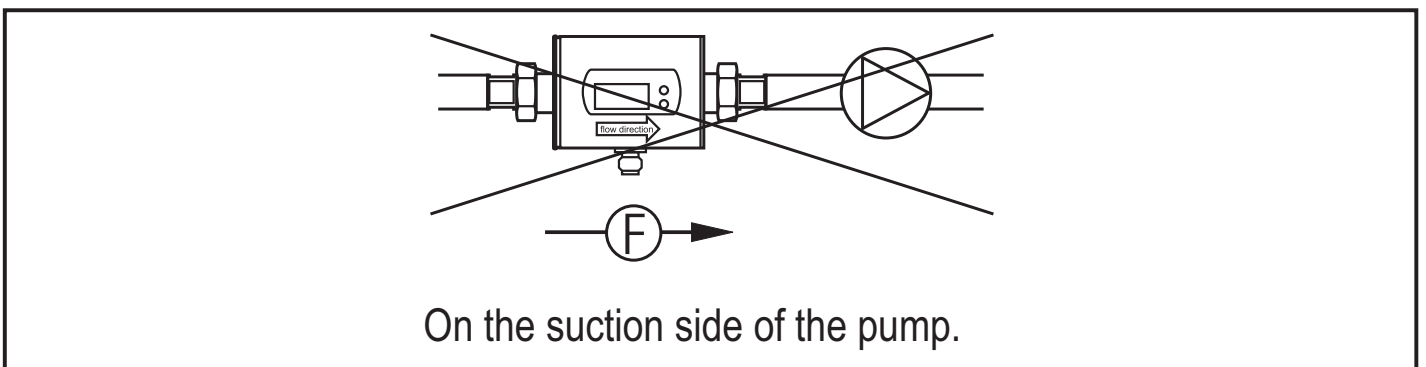
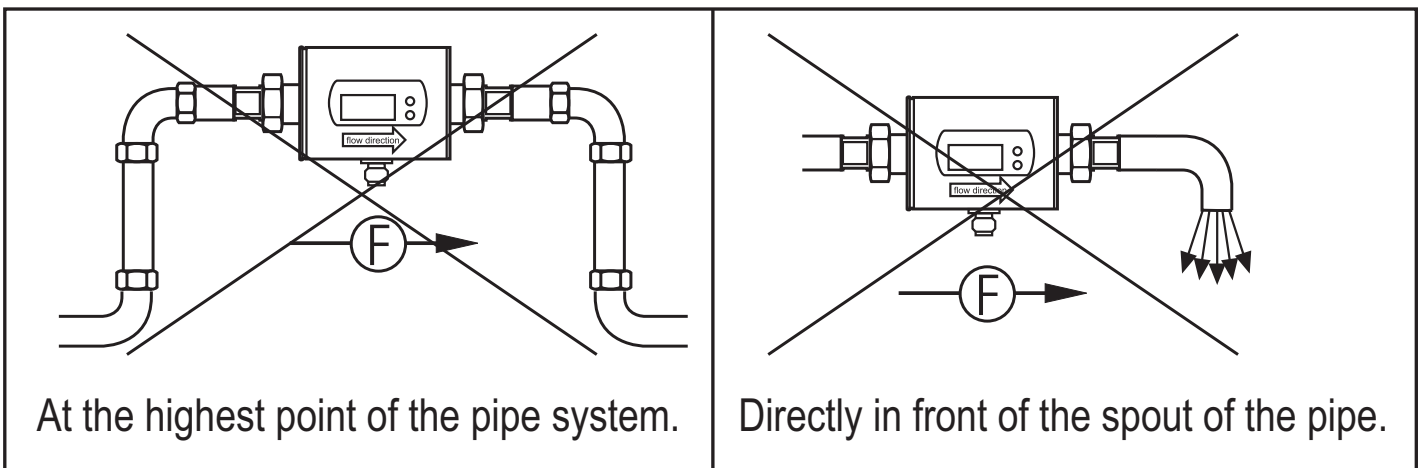
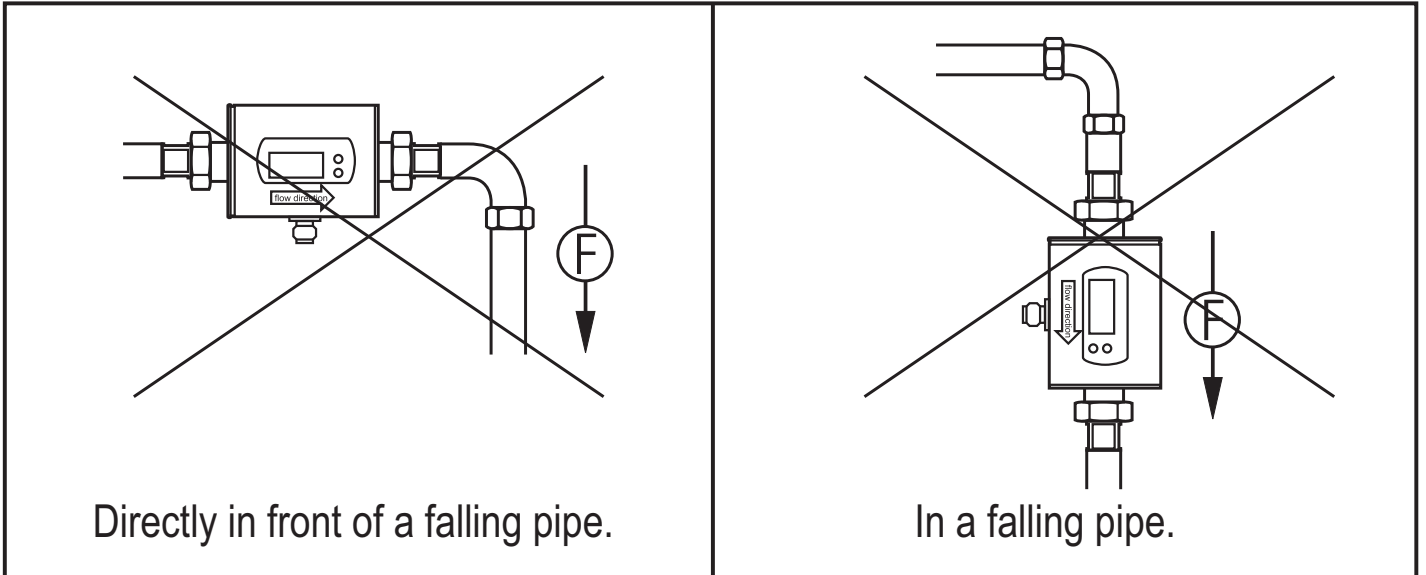

F = flow direction

## 5.3 Grounding



If installed in an ungrounded pipe system (e.g. plastic pipes), the unit must be grounded (functional earth).

Ground brackets for the M12 connector are available as accessories (→ [www.automationdirect.com](http://www.automationdirect.com)).

## 6 Electrical connection



The unit must be connected by a qualified electrician.

The national and international regulations for the installation of electrical equipment must be adhered to.

Voltage supply according to EN 50178, SELV, PELV.

- ▶ Disconnect power.
- ▶ Connect the unit as follows:

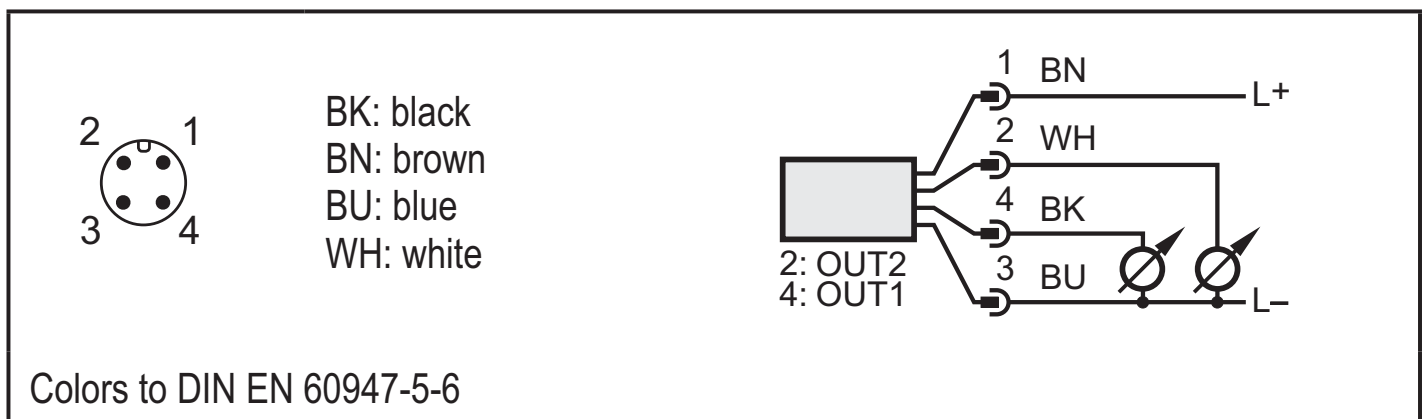

Pin1	L+
Pin3	L-
Pin4 (OUT1)	Analog signal for temperature.
Pin2 (OUT2)	Analog signal for flow rate.

## 7 Operating and display elements

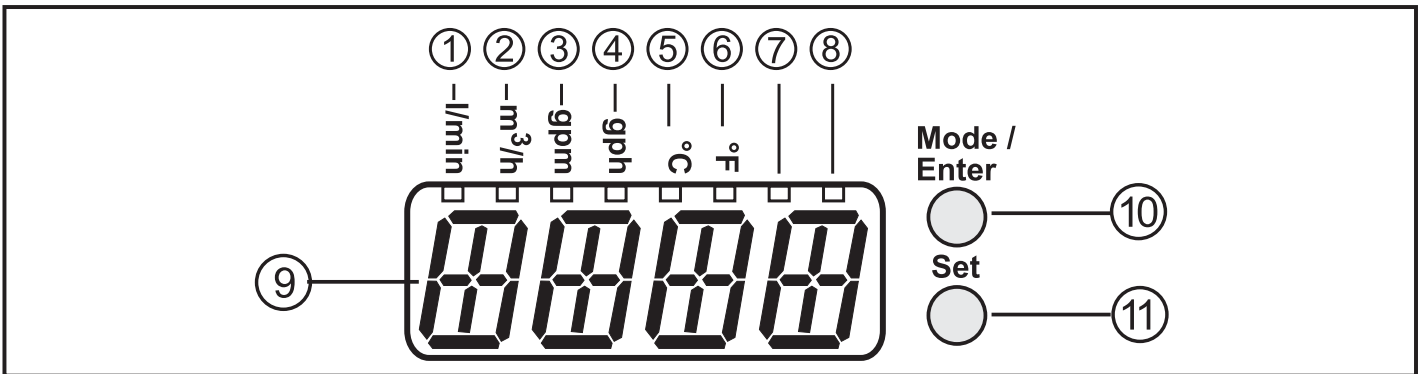

### 1 to 8: Indicator LEDs

- LED 1 = current flow rate in liters/minute.
- LED 2 = current flow rate in cubic meters/hour.
- LED 3 = current flow rate in gallons per minute (gpm).
- LED 4 = current flow rate in gallons per hour (gph).
- LED 5 = current medium temperature in °C.
- LED 6 = current medium temperature in °F.
- LED 7, LED 8 = not used.

### 9: Alphanumeric display, 4 digits

- Indication of the current flow rate (if [SELd] = [FLOW] is set).
- indication of the current medium temperature (if [SELd] = [TEMP] is set).
- indication of the parameters and parameter values.

### 10: Mode/Enter pushbutton

- Selection of the parameters and acknowledgement of the parameter values.

### 11: Set pushbutton

- Setting of the parameter values (scrolling by holding pressed, incremental by pressing briefly).
- Change of the display unit in the normal operating mode (Run mode).

# 8 Menu

## 8.1 Menu structure

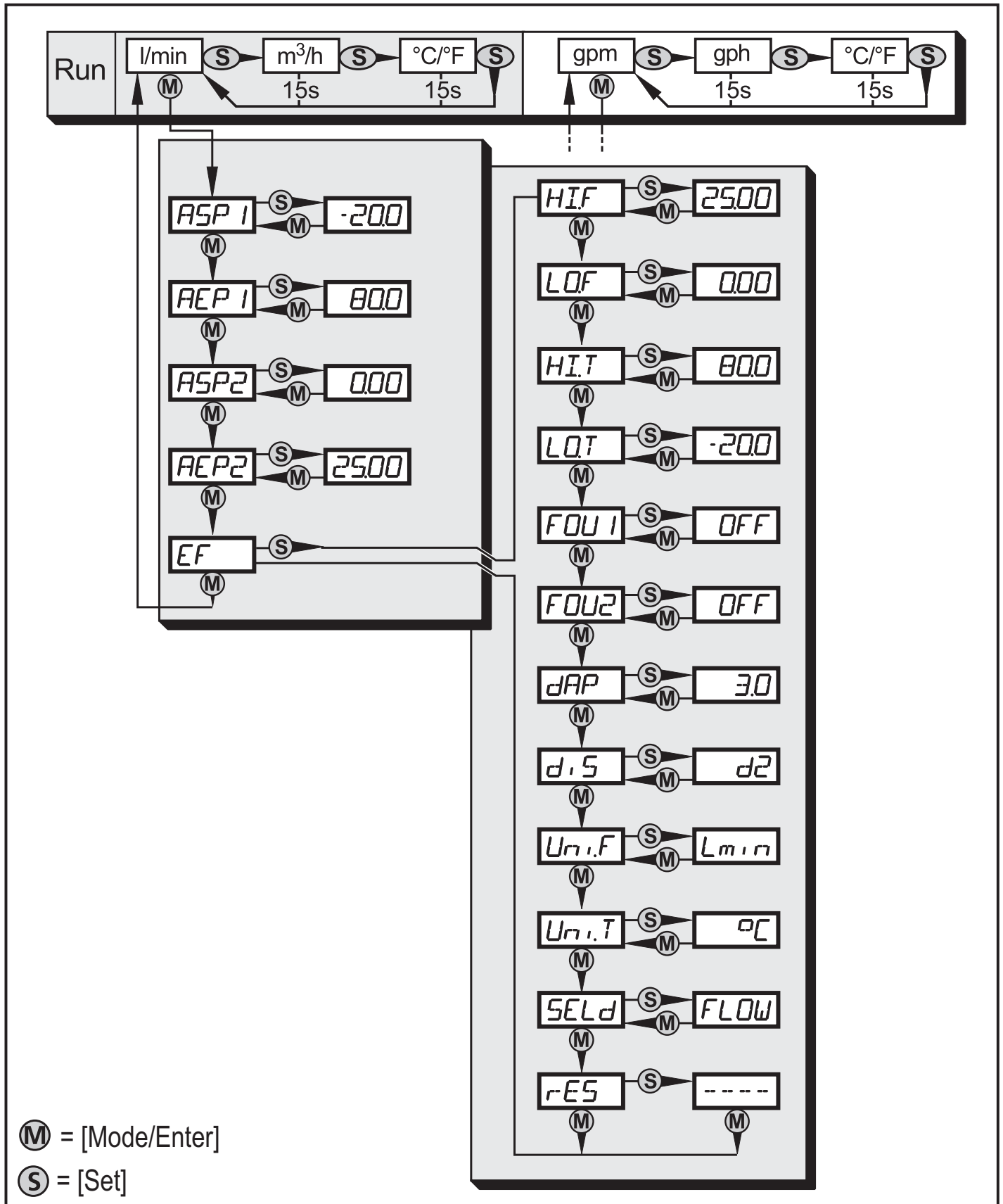

In the Run mode, different display units are accessible (depending on the setting of the parameters [SELd], [Uni.F] and [Uni.T], → 10.4).

## 8.2 Explanation of the menu

ASP1	Analog start value for temperature.
AEP1	Analog end value for temperature.
ASP2	Analog start value for flow rate.
AEP2	Analog end value for flow rate.
EF	Extended functions / opening of menu level 2.
HI.F	Maximum value memory for flow rate.
LO.F	Minimum value memory for flow rate.
HI.T	Maximum value memory for temperature.
LO.T	Minimum value memory for temperature.
FOU1	Behaviour of output 1 in case of an internal fault.
FOU2	Behaviour of output 2 in case of an internal fault.
dAP	Measured value damping / damping constant in seconds.
diS	Update rate and orientation of the display.
Uni.F	Standard unit of measurement for flow rate: litres/minute (lmin), cubic metres/hour (m <sup>3</sup> h), gallons per minute (gpm) or gallons per hour (gph).
Uni.T	Standard unit of measurement for temperature: °C or °F.
SELd	Standard process category of the display: flow rate value or medium temperature.
res	Restore factory setting.

## 9 Set-up

After power on and completion of the power-on delay time (approx. 5 seconds) the unit is in the normal operating mode. It carries out its measurement and evaluation functions and generates output signals according to the set parameters.

- ▶ The output signals are at the maximum value during power up.

## 10 Parameter setting

Parameters can be set before installation and set-up of the unit or during operation.



If you change parameters during operation, this will influence the function.

- ▶ Ensure that there will be no malfunction in your plant.

During parameter setting the unit remains in the operating mode. It continues its monitoring function with the existing parameters until the parameter setting has been completed.

### CAUTION

For medium temperatures above 50 °C some parts of the housing can heat up to over 65 °C.

- ▶ Do not press the pushbuttons manually; instead use another object (e.g. ballpoint pen).

## 10.1 Parameter setting in general

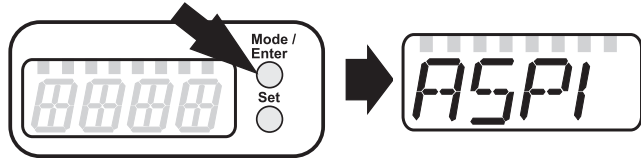
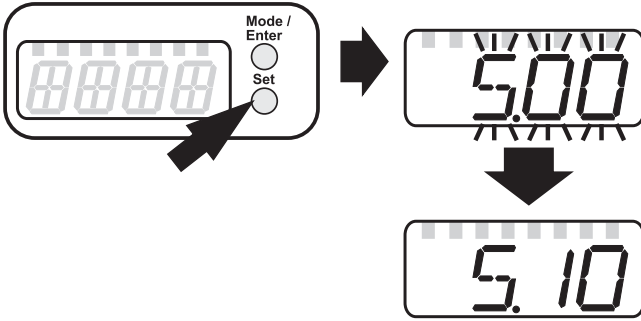
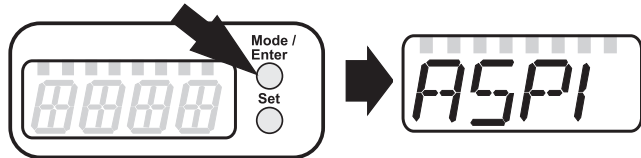
<p><b>1</b></p>	<p><b>Select parameter</b></p> <ul style="list-style-type: none"> <li>▶ Press [Mode/Enter] until the requested parameter is displayed.</li> </ul>	
<p><b>2</b></p>	<p><b>Changing the parameter value</b></p> <ul style="list-style-type: none"> <li>▶ Press [Set] and keep it pressed.</li> <li>&gt; Current setting value of the parameter flashes for 5 s.</li> <li>&gt; After 5 s: The setting value is changed: incremental by pressing briefly or scrolling by holding pressed.</li> </ul> <p>Numerical values are incremented continuously. If the value is to be reduced: let the display move to the maximum setting value. Then the cycle starts again at the minimum setting value.</p>	
<p><b>3</b></p>	<p><b>Confirm the parameter value</b></p> <ul style="list-style-type: none"> <li>▶ Press [Mode/Enter] briefly.</li> <li>&gt; The parameter is displayed again. The new setting value is stored.</li> </ul>	
<p><b>Setting of other parameters:</b></p> <ul style="list-style-type: none"> <li>▶ Start again with step 1.</li> </ul>		
<p><b>Finishing the parameter setting</b></p> <ul style="list-style-type: none"> <li>▶ Press [Mode/Enter] several times until the current measured value is displayed or wait for 15 s.</li> <li>&gt; The unit returns to the operating mode.</li> </ul>		

### 10.1.1 Switching between the menu levels

<p>Change to the submenu</p>	<ul style="list-style-type: none"> <li>▶ Press [Mode/Enter] until [EF] is displayed.</li> </ul>
<p>Back to the process value display</p>	<ul style="list-style-type: none"> <li>▶ Press [Set] briefly.</li> <li>&gt; The first parameter of the sub-menu is displayed (here: [HI.F]).</li> </ul>



## 10.1.2 Locking / unlocking

The unit can be locked electronically to prevent unintentional settings. On delivery: not locked.

Locking	<ul style="list-style-type: none"><li>▶ Make sure that the unit is in the normal operating mode.</li><li>▶ Press [Mode/Enter] + [Set] for 10 s.</li><li>&gt; [Loc] is displayed.</li></ul>  During operation: > [Loc] is briefly displayed if you try to change parameter values.
Unlocking	<ul style="list-style-type: none"><li>▶ Press [Mode/Enter] + [Set] for 10 s.</li><li>&gt; [uLoc] is displayed.</li></ul>

## 10.1.3 Timeout

If no button is pressed for 30 s during parameter setting, the unit returns to the operating mode with unchanged parameter.

## 10.2 Setting the analog value for temperature

<ul style="list-style-type: none"><li>▶ Select [ASP1] and set the value at which the minimum value is provided.</li><li>▶ Select [AEP1] and set the value at which the maximum value is provided.</li></ul>	ASP1 AEP1
---	--------------

## 10.3 Setting the analog value for flow rate

<ul style="list-style-type: none"><li>▶ Select [ASP2] and set the value at which the minimum value is provided.</li><li>▶ Select [AEP2] and set the value at which the maximum value is provided</li></ul>	ASP2 AEP2
--	--------------

## 10.4 User settings (optional)

### 10.4.1 Determine the standard unit of measurement for flow rate

<ul style="list-style-type: none"><li>▶ Select [Uni.F] and set the unit of measurement: [Lmin], [m3h], [GPm] or [GPh].</li></ul>	Uni.F
--	-------

### 10.4.2 Determine the standard unit of measurement for temperature

<ul style="list-style-type: none"><li>▶ Select [Uni.T] and set the unit of measurement: [°C] or [°F].</li></ul>	Uni.T
---	-------

### 10.4.3 Configuration of the standard display

<ul style="list-style-type: none"> <li>▶ Select [SELd] and determine the standard process category.             <ul style="list-style-type: none"> <li>- [FLOW] = display shows the current flow rate value in the standard unit of measurement.</li> <li>- [TEMP] = display indicates the current medium temperature in the standard unit of measurement.</li> </ul> </li> <li>▶ Select [diS] and determine the update rate and orientation of the display:             <ul style="list-style-type: none"> <li>- [d1] = update of the measured values every 50 ms.</li> <li>- [d2] = update of the measured values every 200 ms.</li> <li>- [d3] = update of the measured values every 600 ms.</li> <li>- [rd1], [rd2], [rd3] = display as for d1, d2, d3; rotated by 180°.</li> <li>- [OFF] = the display is switched off in the operating mode.</li> </ul> </li> </ul>	
---	---

### 10.4.4 Setting the measured value damping

<ul style="list-style-type: none"> <li>▶ Select [dAP] and the damping constant in seconds (t value 63 %).</li> </ul>	
--	---

### 10.4.5 Setting the error behaviour of OUT1 / OUT2

<ul style="list-style-type: none"> <li>▶ Select [FOU1] and determine the value:             <ul style="list-style-type: none"> <li>- [On] = the analog signal goes to the upper end stop value.</li> <li>- [OFF] = the analog signal goes to the lower end stop value.</li> <li>- [OU] = the analog signal corresponds to the measured value.</li> </ul> </li> <li>▶ Select [FOU2] and determine the value:             <ul style="list-style-type: none"> <li>- [On] = the analog signal goes to the upper end stop value.</li> <li>- [OFF] = the analog signal goes to the lower end stop value.</li> <li>- [OU] = the analog signal corresponds to the measured value.</li> </ul> </li> </ul>	
--	--

## 10.5 Service functions

### 10.5.1 Reading the min./max. values for flow rate

<ul style="list-style-type: none"> <li>▶ Select [HI.F] or [LO.F] and press [Set] briefly. [HI.F] = maximum value, [LO.F] = minimum value.</li> </ul> <p>Delete memory:</p> <ul style="list-style-type: none"> <li>▶ Select [HI.F] or [LO.F].</li> <li>▶ Press [Set] and keep it pressed until [----] is displayed.</li> <li>▶ Press [Mode/Enter] briefly.</li> </ul> <p>It is recommended to delete the memories as soon as the unit works under normal operating conditions for the first time.</p>	
--	---

## 10.5.2 Reading the min./max. values for temperature

- ▶ Select [HI.T] or [LO.T] and press [Set] briefly.  
[HI.T] = maximum value, [LO.T] = minimum value.

Speicher löschen:

- ▶ Select [HI.T] or [LO.T].
- ▶ Press [Set] and keep it pressed until [----] is displayed.
- ▶ Press [Mode/Enter] briefly.

It is recommended to delete the memories as soon as the unit works under normal operating conditions for the first time.

The image shows a digital display with two lines. The top line displays "HI.T" and the bottom line displays "LO.T".

## 10.5.3 Reset all parameters to the factory setting

- ▶ Select [rES], then press [Set] and keep it pressed until [----] is displayed

- ▶ Press [Mode/Enter] briefly.

For the factory settings please refer to the end of these instructions → 13.

We recommend recording your own settings in that table before carrying out a reset.

The image shows a digital display with one line displaying "r-ES".

# 11 Operation

## 11.1 Reading the process value

The LEDs 1-6 signal which process value is currently displayed.

The process value to be displayed as standard (temperature, flow rate) can be preset. → 10.4.3 Configuration of the standard display. A standard unit of measurement can be defined for the flow rate (l/min, m<sup>3</sup>/h, gpm or gph) → 10.4.1). For temperature measurement, °C or °F can be selected as standard unit of measurement (→ 10.4.2).

Further process values can be read in addition to the preset standard display:

- ▶ Press [Set] briefly.
- > The LED of the selected process value display is lit and the current process value is displayed.
- > After 15 seconds the display changes to the standard display.

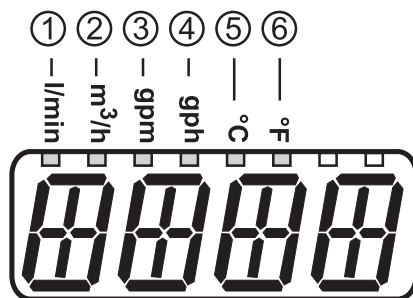

LED	Process value display	Unit
1	Current flow volume per minute	l / min
2	Current flow volume per hour	m <sup>3</sup> / h
3	Current flow volume per minute	gal / min
4	Current flow volume per hour	gal / h
5	Current medium temperature	°C
6	Current medium temperature	°F

## 11.2 Reading the parameter value

<p><b>Select parameter</b></p> <p>▶ Press [Mode/Enter] until the requested parameter is displayed.</p>	
<p><b>Display the parameter value</b></p> <p>▶ Press [Set] briefly.</p> <p>&gt; The unit displays the corresponding parameter value for approx. 15 s. Then the unit returns to the Run mode.</p>	

## 11.3 Error indications

	Warning message
[OL]	Detection zone of flow rate or temperature exceeded. Measured value between 120 % and 130 % of the final value of the measuring range.
[UL]	Below the detection zone of flow rate or temperature. Measured value between -120 % and -130 % of the final value of the measuring range.
[Err]	<ul style="list-style-type: none"> <li>• Unit faulty / malfunction.</li> <li>• Measured value greater than 130 % of the final value of the measuring range.</li> <li>• Measured value lower than -130 % of the final value of the measuring range.</li> </ul>
[Loc]	Setting pushbuttons locked, parameter change rejected.

## 12 Technical data

Technical data and scale drawing at [www.automationdirect.com](http://www.automationdirect.com).

## 13 Factory setting

	Factory setting			User setting
	FMM50-1002	FMM75-1002	FMM100-1002	
ASP1	-20.0	-20.0	-20.0	
AEP1	80.0	80.0	80.0	
ASP2	0.0	0.0	0.0	
AEP2	25.0	50.0	100.0	
FOU1	OFF	OFF	OFF	
FOU2	OFF	OFF	OFF	
dAP	3	3	3	
diS	d2	d2	d2	
Uni.F	Lmin	Lmin	Lmin	
Uni.T	°C	°C	°C	
SELd	FLOW	FLOW	FLOW	

More information at [www.automationdirect.com](http://www.automationdirect.com)