

proense®



Operating instructions
Magnetic-inductive flow meter

FMM50-1001

FMM75-1001

FMM100-1001

80229913 / 00 07 / 2015

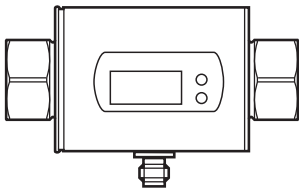

by Automationdirect.com

Contents

1	Preliminary note	4
1.1	Symbols used	4
1.2	Warning signs used	4
2	Safety instructions	4
3	Functions and features	5
4	Function	6
4.1	Measuring principle for flow rate monitoring	6
4.2	Processing of the measured signals	7
4.3	Flow rate monitoring	7
4.3.1	Flow rate quantity	7
4.3.2	Direction of flow	7
4.4	Volumetric totalizer function	7
4.4.1	Volumetric totalizer monitoring with pulse output	8
4.4.2	Volumetric totalizer monitoring with preset counter	8
4.5	Temperature monitoring	9
4.6	Flow rate or temperature monitoring / switching function	9
4.6.1	Hysteresis function	9
4.6.2	Window function	10
4.7	Flow rate or temperature monitoring / analog function	11
4.7.1	Current output	11
4.7.2	Voltage output	12
4.8	Start-up delay	13
5	Installation	16
5.1	Recommended installation position	16
5.2	Not recommended installation position	17
5.3	Grounding	18
6	Electrical connection	18
7	Operating and display elements	20
8	Menu	21
8.1	Menu structure	21
8.2	Explanation main menu	22
9	Set-up	23
10	Parameter setting	23

10.1	General parameter setting.....	24
10.1.1	Switching between the menu levels	24
10.1.2	Locking / unlocking	25
10.1.3	Timeout.....	25
10.2	Settings for flow rate monitoring	25
10.2.1	Settings for limit value monitoring with OUT1.....	25
10.2.2	Settings for limit value monitoring with OUT2.....	25
10.2.3	Setting the analog value for flow rate	26
10.3	Settings for monitoring of volumetric totalizer	26
10.3.1	Settings for volumetric totalizer monitoring by pulse output.....	26
10.3.2	Settings for volumetric totalizer monitoring by the preset counter...26	
10.3.3	Setting the pulse value.	26
10.3.3	Counter reset	27
10.3.4	Deactivation of the counter reset.....	27
10.3.5	Configure counter reset using an external signal	27
10.4	Settings for temperature monitoring	28
10.4.1	Settings for limit value monitoring with OUT2.....	28
10.4.2	Setting the analog value for temperature	28
10.5	User settings (optional).....	28
10.5.1	Setting of the standard unit of measurement for flow rate.....	28
10.5.2	Configuration of the standard display	28
10.5.3	Setting the output logic.....	29
10.5.4	Setting the start-up delay.....	29
10.5.5	Setting the measured value damping	29
10.5.6	Setting the error behaviour of the outputs	29
10.6	Service functions	29
10.6.1	Reading the min/max values for the flow rate	29
10.6.2	Resetting all parameters to factory setting	30
11	Operation	31
11.1	Reading the process value	31
11.2	Reading the parameter value.....	32
11.3	Error indications.....	32
12	Technical data.....	32
13	Factory setting	33

1 Preliminary note

1.1 Symbols used

- ▶ Instruction
- > Reaction, result
- [...] Designation of keys, buttons or indications
- Cross-reference



Important note

Non-compliance can result in malfunction or interference.



Information

Supplementary note.

1.2 Warning signs used

CAUTION

Warning of personal injury.
Injuries may result.

2 Safety instructions

- Please read this document prior to set-up of the unit. Ensure that the product is suitable for your application without any restrictions.
- If the operating instructions or the technical data are not adhered to, personal injury and/or damage to property can occur.
- Improper or non-intended use may lead to malfunctions of the unit or to unwanted effects in your application. That is why installation, electrical connection, set-up, operation and maintenance of the unit must only be carried out by qualified personnel authorized by the machine operator.
- In order to guarantee the correct condition of the device for the operating time the device must only be used in media to which the wetted parts are sufficiently resistant (→ Technical data).
- The responsibility to determine whether the measurement devices are suitable for the respective application lies with the operator. The manufacturer assumes no liability for consequences of misuse by the operator. Improper installation and use of the devices result in a loss of the warranty claims.

- For medium temperatures above 122 °F some parts of the housing can heat up to over 149 °F. Moreover, during installation or in case of a fault (e.g. housing damage) media under high pressure or hot media can leak from the system. To avoid personal injury, take the following measures:
 - ▶ Install the unit according to the applicable rules and regulations.
 - ▶ Ensure that the system is free of pressure during installation.
 - ▶ Protect the housing against contact with flammable substances and unintentional contact. To do so, equip the unit with suitable protection (e.g. protective cover).
 - ▶ Do not press the pushbuttons manually; instead use another object (e.g. ballpoint pen).

3 Functions and features

The unit monitors liquid media.

The unit detects the 3 process categories flow rate, volumetric totalizer and medium temperature.



Pressure Equipment Directive (PED):

The units comply with the Pressure Equipment Directive and are designed and manufactured for group 2 fluids in accordance with sound engineering practice. Use of group 1 fluids on request.

Application area

Conductive liquids with the following properties:

- Conductivity: $\geq 20 \mu\text{S/cm}$
- Viscosity: $< 70 \text{ cST}$ at 40°C / 104°F

4 Function

4.1 Measuring principle for flow rate monitoring

The magnetic-inductive measuring principle means that a magnetic field is generated in the measuring pipe via current-carrying coils. When a conductive medium flows through the measuring pipe, the ions therein are diverted perpendicularly to the magnetic field. Positive and negative charge carriers flow in opposite directions. The voltage induced is measured by two electrodes that are in contact with the medium. This signal voltage is directly proportional to the average flow velocity. The flow rate is derived from the internal pipe diameter.

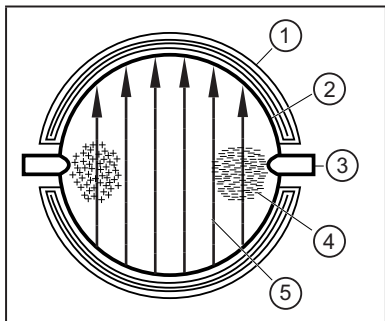

- 1: Field coil
- 2: Measuring pipe
- 3: Electrode
- 4: Charge carrier in the medium
- 5: Magnetic field



Both electrodes must be in contact with the medium.

4.2 Processing of the measured signals

The unit displays the current process values.

It generates 2 output signals according to the parameter setting.

OUT1: 3 selection options

- Flow rate switch
- Volumetric totalizer pulse
- Volumetric totalizer preset switch

Parameter setting

- (→ 10.2.1)
- (→ 10.3.1)
- (→ 10.3.2)

OUT2: 5 selection options

- Flow rate switch
- Temperature switch
- Analog flow rate
- Analog temperature
- Volumetric totalizer reset (input)

Parameter setting

- (→ 10.2.2)
- (→ 10.4.1)
- (→ 10.2.3)
- (→ 10.4.2)
- (→ 10.3.5)

4.3 Flow rate monitoring

4.3.1 Flow rate

The signals for measuring the flow rate can be provided as follows:

1. Two switching signals for flow rate limit values on output 1 and output 2. (On the switching functions → 4.6)
2. An analog signal (4...20 mA or 0...10 V) on output 2. (On the analog functions → 4.7)

4.3.2 Direction of flow

In addition to the flow rate, the unit also detects the flow direction. An arrow on the unit indicates the positive flow direction.

Direction of flow in accordance with "flow direction"

> process value and display positive.

Direction of flow against the "flow direction"

> process value and display negative.



Only positive process values are processed for the signal output (limit values and analog values for flow rate).

4.4 Volumetric totalizer monitoring

The unit has an internal totalizer which continuously totals the flow rate.

The sum corresponds to the current consumed quantity since the last reset.

- The volumetric totalizer takes account of the flow direction for totalization.
 - Flow according to the marked flow direction (arrow "flow direction"): meter adds.
 - Flow against the marked flow direction: meter subtracts.
 - Meter pulses are only provided as the sum increases. After subtraction (consumed quantity decreases), the pulses are only provided again when the consumed quantity has exceeded the previous maximum value.

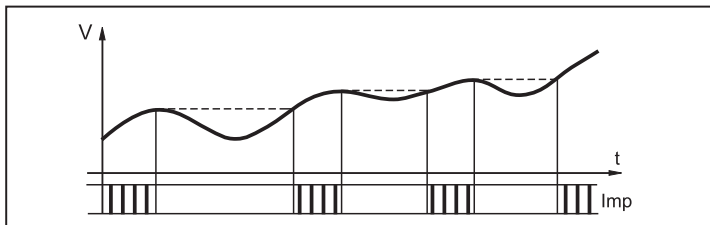

V = flow volume, Imp = output pulses

- The current meter reading can be displayed (→ 11.1 Reading the process value).
- In addition the value before the last reset is stored. This value can also be displayed (→ 11.1 Reading the process value).
 - The meter saves the totalled consumed quantity every 10 minutes. In the event of a power failure this value is retained as the current meter reading. If a time-controlled reset is set, the elapsed time of the set reset interval is also stored. So the possible data loss is a maximum of 10 minutes.

There are different ways to reset the meter

→ 10.3.3 Manual counter reset

→ 10.3.3 Time-controlled counter-reset

→ 10.3.5 Configure counter reset using an external signal

4.4.1 Volumetric totalizer monitoring with pulse output

Output 1 indicates a counting pulse when the set flow volume has been reached (→ 10.3.1).

4.4.2 Volumetric totalizer monitoring with preset counter

Output 1 switches when the set flow volume has been reached (→ 10.3.2).

- If the volume x is reached, output 1 switches and remains switched until the meter is reset.

4.5 Temperature monitoring

The following signals are provided for temperature monitoring:

- A switching signal for temperature limit values on output 2. (On the switching functions → 4.6)
- An analog signal proportional to the temperature (4...20 mA or 0...10 V) on output 2. (On the analog functions → 4.7)

4.6 Flow rate or temperature monitoring / switching function

OUTx changes its switching state if it is above or below the set switching limits (SPx, rPx). The following switching functions can be selected:

4.6.1 Hysteresis function

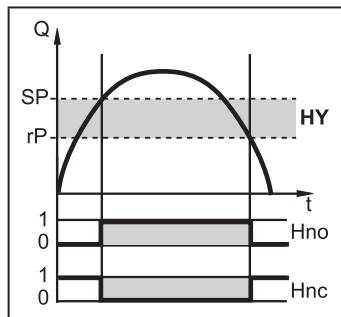

Example of flow rate monitoring
HY = hysteresis

Normally open: [OUx] = [Hno]

Normally closed: [OUx] = [Hnc]

First the set point (SPx) is set, then the reset point (rPx) with the requested difference.



When SPx is adjusted rPx is changed automatically; the difference remains constant.

4.6.2 Window function

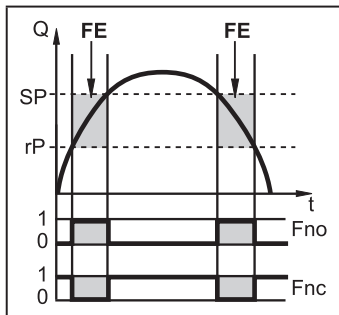

Example of flow rate monitoring

FE = window

Normally open: $[OUx] = [Fno]$

Normally closed: $[OUx] = [Fnc]$

The width of the window can be set by means of the difference between SPx and rPx .

SPx = upper value

rPx = lower value.



When set to the window function the set and reset points have a fixed hysteresis of 0.25 % of the final value of the measuring range. This keeps the switching state of the output stable if the flow rate varies slightly.

4.7 Flow rate or temperature monitoring / analog function

4.7.1 Current output

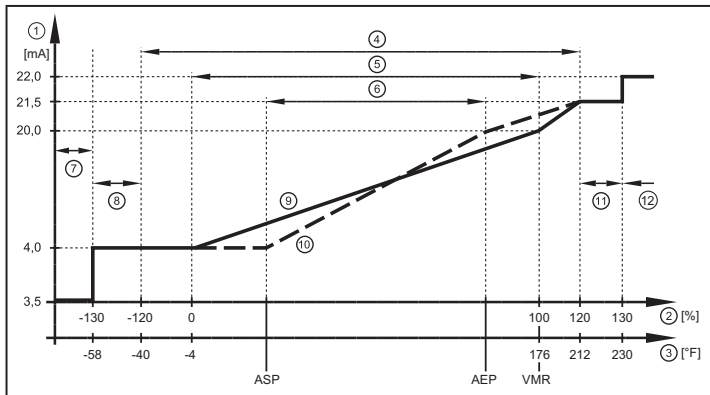

Characteristics of the analog output according to the standard IEC 60947-5-7

- 1: Output current
- 2: Flow rate
- 3: Temperature
- 4: Display range
- 5: Measuring range
- 6: Range between analog start point and analog end point
- 7: The unit is in the error state (FOU = OFF).
- 8: The process value transmitted in an analog way is therefore below the display range.
- 9: Curve of the analog signal at factory setting
- 10: Curve of the analog signal with shifted ASP and AEP
- 11: The process value transmitted in an analog way is therefore above the display range.
- 12: The unit is in the error state (FOU = ON).

ASP = analog start point: determines at which measured value the output signal is 4 mA

AEP = analog end point: determines at which measured value the output signal is 20 mA

VMR = final value of the measuring range = 100 %



Minimum distance between ASP and AEP = 20 % of the measuring range

In the set scaling range the output signal is between 4 and 20 mA.

4.7.2 Voltage output

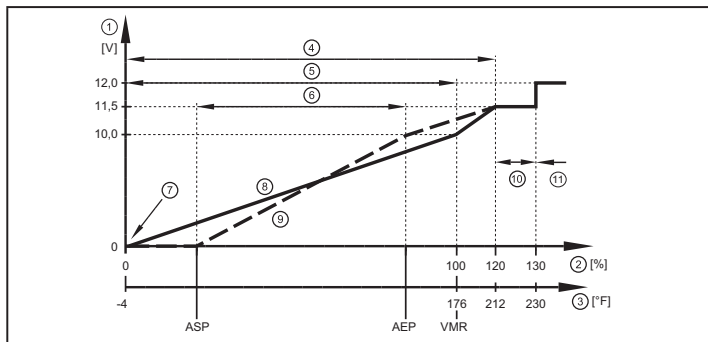

Characteristics of the analog output according to the standard IEC 60947-5-7

- 1: Output voltage
- 2: Flow rate
- 3: Temperature
- 4: Display range
- 5: Measuring range
- 6: Range between analog start point and analog end point
- 7: The unit is in the error state (FOU = OFF) or the process value transmitted in an analog way is below the display range.
- 8: Curve of the analog signal at factory setting
- 9: Curve of the analog signal with shifted ASP and AEP
- 10: The process value transmitted in an analog way is therefore above the display range.
- 11: The unit is in the error state (FOU = ON).

ASP = analog start point: determines at which measured value the output signal is 0 V

AEP = analog end point: determines at which measured value the output signal is 10 V

VMR = final value of the measuring range = 100 %



Minimum distance between ASP and AEP = 20 % of the measuring range

In the set scaling range the output signal is between 0 and 10 V.

4.8 Start-up delay



The start-up delay dST influences the switching outputs of the flow rate monitoring.

If the start-up delay is active ($dST > 0$), note: As soon as the flow rate exceeds 0.5 % of the final value of the measuring range (VMR), the following processes are carried out:

- > The start-up delay is activated.
- > The outputs switch as programmed:
ON for NO function, OFF for NC function.

After the start of the start-up delay there are 3 options:

1. The flow rate increases quickly and reaches the set point / good range within dST.
 - > Outputs remain active.
2. The flow rate increases slowly and does not reach the set point /good range within dST.
 - > Outputs are reset.
3. Flow rate falls below 0.5 % of the final value of the measuring range (VMR), within dST.
 - > Outputs are reset at once; dST is stopped.

Example: dST for hysteresis function

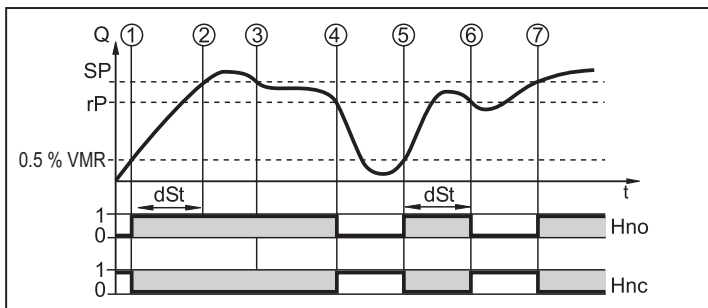

	Condition	Reaction
1	Flow rate Q reaches 0.5 % VMR	dST starts, output becomes active
2	dST elapsed, Q reached SP	output remains active
3	Q below SP but above rP	output remains active
4	Q below rP	output is reset
5	Q reaches again 0.5 % VMR	dST starts, output becomes active
6	dST elapsed, Q has not reached SP	output is reset
7	Q reaches SP	output becomes active

Example: dST for window function

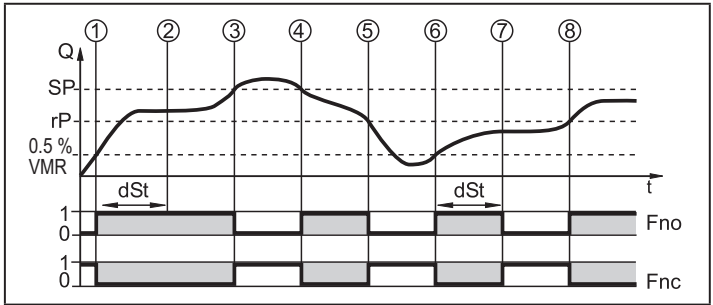

	Condition	Reaction
1	Flow rate Q reaches 0.5 % VMR	dST starts, output becomes active
2	dST elapsed, Q reached good range	output remains active
3	Q above SP (leaves good range)	output is reset
4	Q again below SP	output becomes active again
5	Q below rP (leaves good range)	output is reset again
6	Q reaches again 0.5 % VMR	dST starts, output becomes active
7	dST elapsed, Q has not reached good range	output is reset
8	Q reaches good range	output becomes active

5 Installation



- ▶ Avoid deposits, accumulated gas and air in the pipe system.

5.1 Recommended installation locations

Example of an optimized installation:

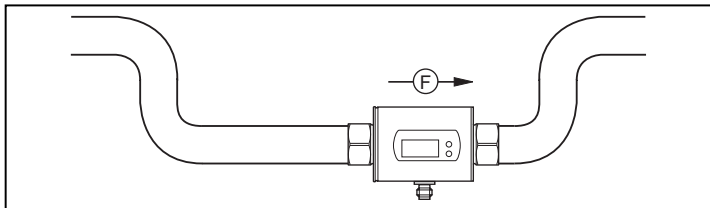

- ▶ Install the unit so that the measuring pipe is completely filled.
- ▶ Arrange for inlet and outlet pipe lengths. Disturbances caused by bends, valves, reductions, etc. are compensated for. It applies in particular: no shut-off and control devices are allowed directly in front of the unit.

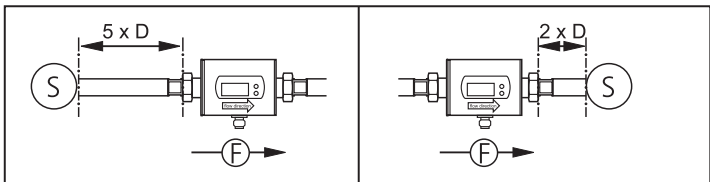

- ▶ Install in front of or in a rising pipe.

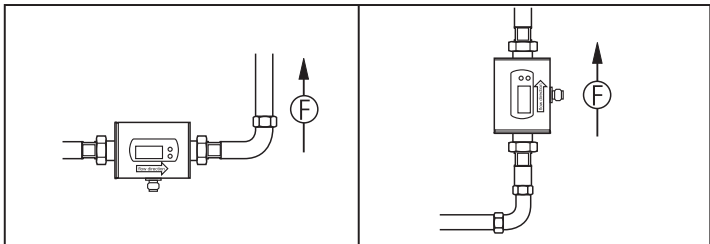



The unit can be installed irrespective of the orientation if the following is ensured:

- No air bubbles can form in the pipe system.
- The pipes are always completely filled.

5.2 Not recommended installation position

► Avoid the following installation positions:

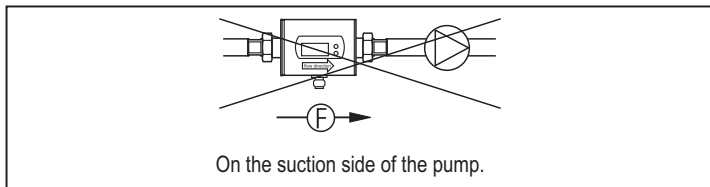
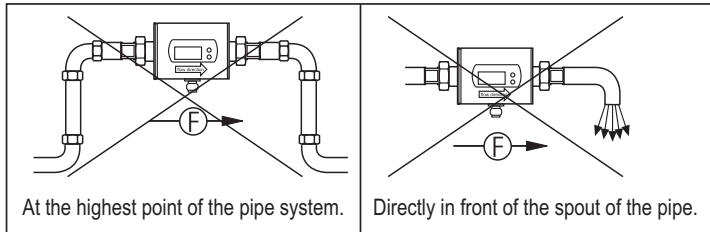
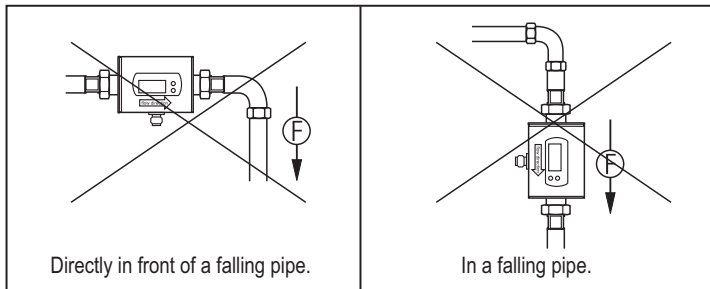

F = flow direction

5.3 Grounding

 If installed in an ungrounded pipe system (e.g. plastic pipes), the unit must be grounded (functional earth).

Ground brackets for the M12 connector are available as accessories (→ www.automationdirect.com).

6 Electrical connection

 The unit must be connected by a qualified electrician. The national and international regulations for the installation of electrical equipment must be adhered to.

Voltage supply according to EN 50178, SELV, PELV.

- ▶ Disconnect power.
- ▶ Connect the unit as follows:

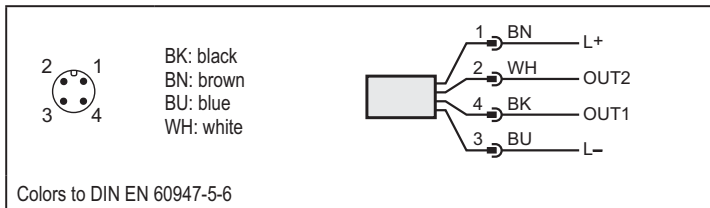

Sample circuits:

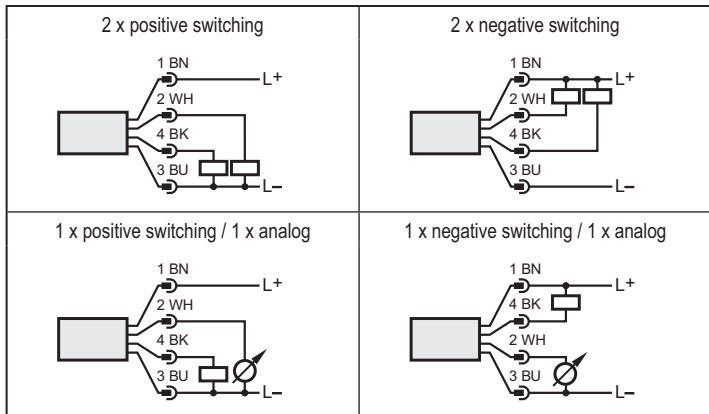

Pin 1	L+
Pin 3	L-
Pin 4 (OUT1)	<ul style="list-style-type: none"> • Flow rate switch: limit values for flow rate • Volumetric totalizer pulse: 1 pulse every time the defined volume is reached. • Volumetric totalizer preset switch
Pin 2 (OUT2/ InD)	<ul style="list-style-type: none"> • Flow rate switch: limit values for flow rate • Temperature switch: limit values for temperature • Analog signal for flow rate • Analog signal for temperature • Volumetric totalizer reset (input)

7 Operating and display elements

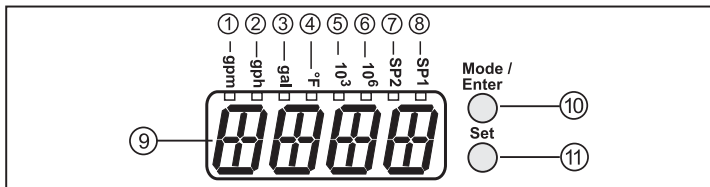

1 to 8: Indicator LEDs

- LED 1 = current flow rate in gallons/min.
- LED 2 = current flow rate in gallons/hour.
- LED 3 = current consumed quantity since the last reset in gallons.
- LED 3 flashing = consumed quantity before the last reset in gallons.
- LED 4 = current medium temperature in °F.
- LEDs 3 and 5 = current consumed quantity since the last reset in 10³ gallons.
- LEDs 3 and 5 flashing = consumed quantity before the last reset in 10³ gallons.
- LEDs 3 and 6 = current consumed quantity since the last reset in 10⁶ gallons.
- LEDs 3 and 6 flashing = consumed quantity before the last reset in 10⁶ gallons.
- LED 7, LED 8 = switching state of the corresponding output.

9: Alphanumeric display, 4 digits

- Indication of the current flow rate (if [SELD] = [FLOW] is set).
- Indication of the meter count (if [SELD] = [TOTL] is set).
- Indication of the current medium temperature (if [SELD] = [TEMP] is set).
- Indication of the parameters and parameter values.

10: Mode/Enter pushbutton

- Selection of the parameters and acknowledgement of the parameter values.

11: Set pushbutton

- Setting of the parameter values (scrolling by holding pressed, incremental by pressing briefly).
- Change of the display unit in the normal operating mode (Run mode).

8 Menu

8.1 Menu structure

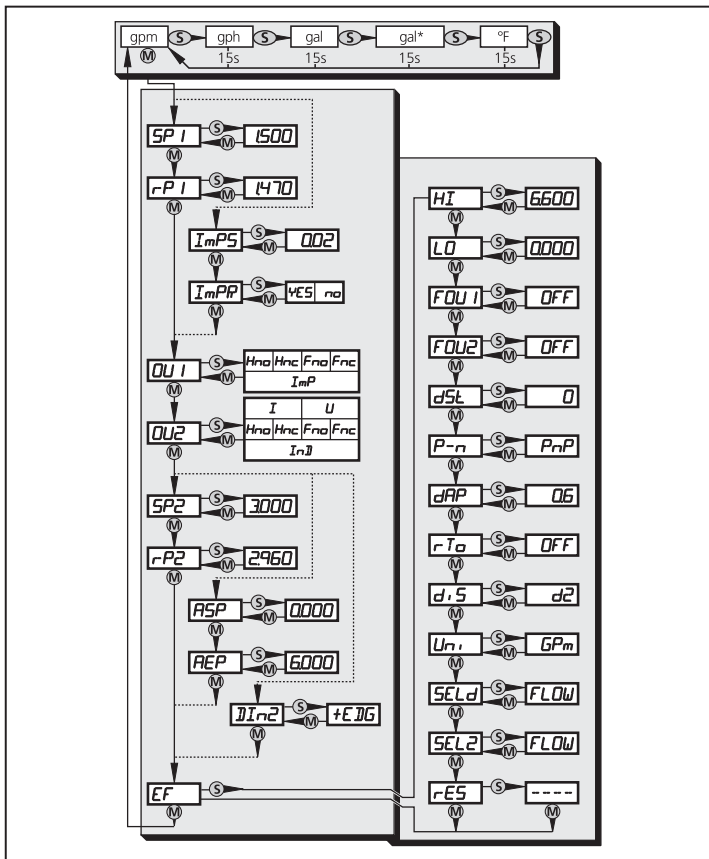

(M) = [Mode/Enter] / (S) = [Set]

gal = current meter count in gallons, 10^3 or 10^6 gallons

gal* = stored meter count in gallons, 10^3 or 10^6 gallons

8.2 Explanation of the menu

SP1/rP1	Maximum / minimum value for flow rate.
ImPS	Pulse value.
ImPR	Pulse repetition active (= pulse output) or not active (= function preset meter).
OU1	Output function for OUT1 (flow rate or volumetric totalizer): - Switching signal for limit values: hysteresis function or window function, normally open or normally closed. - Pulse or switching signal for flow volume.
OU2	Output function for OUT2 (flow rate or temperature): - Switching signal for limit values: hysteresis function or window function, normally open or normally closed. - Analog signal: 4-20 mA [I] or 0-10 V [U].
	As an alternative: configure OUT2 (pin 2) as input for the external volumetric totalizer reset signal: setting: [OU2] = [InD].
SP2/rP2	Maximum / minimum value for flow rate or temperature.
ASP	Analog start value for flow rate or temperature.
AEP	Analog end value for flow rate or temperature.
DIn2	Configuration of the input (pin 2) for meter reset.
EF	Extended functions / opening of menu level 2.
HI	Maximum value memory for flow rate.
LO	Minimum value memory for flow rate.
FOU1	Behaviour of output 1 in case of an internal fault.
FOU2	Behaviour of output 2 in case of an internal fault.
dSt	Start-up delay.
P-n	Output logic: pnp / npn.
dAP	Measured value damping / damping constant in seconds.
rTo	Meter reset: manual reset / time-controlled reset.
diS	Update rate and orientation of the display.
Uni	Standard unit of measurement for flow rate: gallons/min or gallons/h.
SELd	Standard process category of the display: flow rate value / meter count / medium temperature.
SEL2	Standard process category for evaluation by OUT2: - Limit value signal or analog signal for flow rate. - Limit value signal or analog signal for temperature.
res	Restore factory setting.

9 Set-up

After power on and completion of the power-on delay time (approx. 5 seconds) the unit is in the normal operating mode. It carries out its measurement and evaluation functions and generates output signals according to the set parameters.

- ▶ During the power-on delay time, the outputs are switched as programmed:
 - ON with normally open function (Hnc / Fno)
 - OFF with normally closed function (Hno / Fnc).
- ▶ If output 2 is configured as analog output, the output signal is at 20 mA (current output) or 10 V (voltage output).

10 Parameter setting

Parameters can be set before installation and set-up of the unit or during operation.



If you change parameters during operation, this will influence the function.

- ▶ Ensure that there will be no malfunction in your plant.

During parameter setting the unit remains in the operating mode. It continues its monitoring function with the existing parameters until the parameter setting has been completed.

CAUTION

For medium temperatures above 50 °C some parts of the housing can heat up to over 65 °C.

- ▶ Do not press the pushbuttons manually; instead use another object (e.g. ballpoint pen).

10.1 General parameter setting

3 steps must be taken for each parameter set:

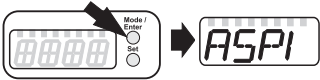
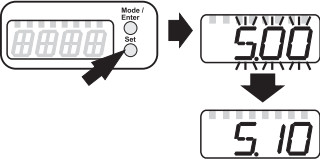
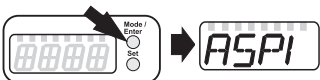
<p>1</p>	<p>Parameter selection</p> <p>▶ Press [Mode/Enter] until the requested parameter is displayed.</p>	
<p>2</p>	<p>Setting of the parameter value</p> <p>▶ Press [Set] and keep it pressed.</p> <p>> Current setting value of the parameter flashes for 5 s.</p> <p>> After 5 s: The setting value is changed: incremental by pressing briefly or scrolling by holding pressed.</p>	
<p>Numerical values are incremented continuously. If the value is to be reduced: let the display move to the maximum setting value. Then the cycle starts again at the minimum setting value.</p>		
<p>3</p>	<p>Acknowledgement of the parameter value</p> <p>▶ Press [Mode/Enter] briefly.</p> <p>> The parameter is displayed again. The new setting value is stored.</p>	
<p>Setting of other parameters:</p> <p>▶ Start again with step 1.</p>		
<p>Finishing the parameter setting:</p> <p>▶ Press [Mode/Enter] several times until the current measured value is displayed or wait for 15 s.</p> <p>> The unit returns to the operating mode.</p>		

10.1.1 Switching between the menu levels

<p>Change to the submenu</p>	<p>▶ Press [Mode/Enter] until [EF] is displayed.</p>
<p>Back to the process value display</p>	<p>▶ Press [Set] briefly.</p> <p>> The first parameter of the sub-menu is displayed (here: [HI.F]).</p>

10.1.2 Locking / unlocking

The unit can be locked electronically to prevent unintentional settings. On delivery: not locked.

Locking	<ul style="list-style-type: none">▶ Make sure that the unit is in the normal operating mode.▶ Press [Mode/Enter] + [Set] for 10 s.> [Loc] is displayed.  During operation: > [Loc] is briefly displayed if you try to change parameter values.
Unlocking	<ul style="list-style-type: none">▶ Press [Mode/Enter] + [Set] for 10 s.> [uLoc] is displayed.

10.1.3 Timeout

If no button is pressed for 15 s during parameter setting, the unit returns to the operating mode with unchanged parameter.

10.2 Settings for flow rate monitoring

10.2.1 Settings for limit value monitoring with OUT1

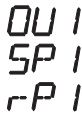
<ul style="list-style-type: none">▶ Select [OU1] and set the switching function:<ul style="list-style-type: none">- [Hno] = hysteresis function/normally open,- [Hnc] = hysteresis function/normally closed,- [Fno] = window function/normally open,- [Fnc] = window function/normally closed.▶ Select [SP1] and set the value at which the output switches.▶ Select [rP1] and set the value at which the output switches back.	
--	---

10.2.2 Settings for limit value monitoring with OUT2

<ul style="list-style-type: none">▶ Select [SEL2] and set [FLOW].▶ Select [OU2] and set the switching function:<ul style="list-style-type: none">- [Hno] = hysteresis function/normally open,- [Hnc] = hysteresis function/normally closed,- [Fno] = window function/normally open,- [Fnc] = window function/normally closed.▶ Select [SP2] and set the value at which the output switches.▶ Select [rP2] and set the value at which the output switches back.	
--	---

10.2.3 Scaling of the analog value for flow rate

- ▶ Select [SEL2] and set [FLOW].
- ▶ Select [OU2] and set the function:
 - [I] = current signal proportional to flow rate (4...20 mA);
 - [U] = voltage signal proportional to flow rate (0...10 V).
- ▶ Select [ASP] and set the value at which the minimum output value is provided.
- ▶ Select [AEP] and set the value at which the maximum output value is provided.

SEL2
OU2
ASP
AEP

10.3 Settings for monitoring of volumetric totalizer

10.3.1 Settings for volume monitoring by pulse output

- ▶ [Select [OU1] and set [ImP].
- ▶ Select [ImPS] and set the volume quantity at which 1 pulse is provided (→ 9.7).
- ▶ Select [ImPR] and set [YES]: pulse repetition is active. Output 1 provides a counting pulse when the value set in [ImPS] is reached.

OU 1
ImPS
ImPR

10.3.2 Settings for volumetric totalizer monitoring using the preset counter

- ▶ Select [OU1] and set [ImP].
- ▶ Select [ImPS] and set the volume quantity at which output 1 switches (→ 9.7).
- ▶ Select [ImPR] and set [no]: pulse repetition is not active. The output switches ON if the value set in [ImPS] is reached. It remains switched until the meter is reset.

OU 1
ImPS
ImPR

10.3.3 Setting the pulse value

- ▶ Set [OU1] to [ImP] (→ 8.3.2).
- ▶ Press [Mode/Enter] until [ImPS] is displayed.
- ▶ Press [Set] and keep it pressed.
 - > The current numerical value flashes for 5 s, then one of the 4 digits becomes active (digit flashes, can be changed).
- ▶ Set the requested value as indicated in the following table.
 - ▶ First select the requested setting range. Then set the figure from the left digit to the right digit.
- ▶ Press [Mode/Enter] briefly when all 4 digits are set.

ImPS

	LED	Display	in steps of	Value
1	3	0 0 . 0 1 ... 9 9 . 9 9	0.01 gal	0.01...99.99 gal
2	3	1 0 . 0 . 0 ... 9 9 . 9 . 9	0.1 gal	100.0...999.9 gal
3	3	1 0 0 0 ... 9 9 9 9	1 gal	1000...9999 gal
4	3 + 5	1 0 . 0 0 ... 9 9 . 9 9	10 gal	10 000...99 990 gal
5	3 + 5	1 0 0 . 0 ... 9 9 9 . 9	100 gal	100 000...999 900 gal
6	3 + 5	1 0 0 0 ... 9 9 9 9	1000 gal	1 000 000... 9 999 000 gal
7	3 + 6	1 0 . 0 0 ... 3 0 . 0 0	10 000 gal	10 000 000... 30 000 000 gal

10.3.4 Settings for meter reset controlled by the program

<ul style="list-style-type: none"> ▶ Select [rTO] and continue with a) or b). <ul style="list-style-type: none"> a) Reset the meter manually: press [Set] until [rES.T] is displayed. Press [Mode/Enter] briefly. b) Enter the value for time-controlled reset: Press [Set] until the requested value is displayed (intervals from 1 hour to 8 weeks). ▶ Press [Mode/Enter] briefly. 	r To
---	------

10.3.5 Switch off the meter reset

<ul style="list-style-type: none"> ▶ Select [rTO] and set [OFF]. The meter is only reset after overflow (= factory setting). 	r To
---	------

10.3.6 Configure counter reset using an external signal

<ul style="list-style-type: none"> ▶ Select [OU2] and then [InD]. ▶ Select [Din2] and set the reset signal: <ul style="list-style-type: none"> - [Hi] = reset for high signal, - [Lo] = reset for low signal, - [+EDG] = reset for rising edge, - [-EDG] = reset for falling edge. 	OU2 D, n2
---	--------------

10.4 Settings for temperature monitoring

10.4.1 Settings for limit value monitoring with OUT2

<ul style="list-style-type: none">▶ Select [SEL2] and set [TEMP].▶ Select [OU2] and set the switching function:<ul style="list-style-type: none">- [Hno] = hysteresis function/normally open,- [Hnc] = hysteresis function/normally closed,- [Fno] = window function/normally open,- [Fnc] = window function/normally closed.▶ Select [SP2] and set the value at which the output switches.▶ Select [RP2] and set the value at which the output switches back.	
--	---

10.4.2 Scaling of the analog value for temperature

<ul style="list-style-type: none">▶ Select [SEL2] and set [TEMP].▶ Select [OU2] and set the function:<ul style="list-style-type: none">- [I] = current signal proportional to temperature (4...20 mA);- [U] = voltage signal proportional to temperature (0...10 V).▶ Select [ASP] and set the value at which the minimum output value is provided.▶ Select [AEP] and set the value at which the maximum output value is provided.	
--	---

10.5 User settings (optional)

10.5.1 Setting of the standard unit of measurement for flow rate

<ul style="list-style-type: none">▶ Select [Uni] and set the unit of measurement: [GPM] or [GPH]. <p>The setting only has an effect on the flow rate value. The counter values (volumetric totalizer) are automatically displayed in the unit of measurement providing the highest accuracy.</p>	
--	---

10.5.2 Configuration of the standard display

<ul style="list-style-type: none">▶ Select [SELd] and determine the standard process category.<ul style="list-style-type: none">- [FLOW] = display shows the current flow rate value in the standard unit of measurement.- [TOTL] = display indicates the current meter count in gal, 10³ gal or 10⁶ gal.- [TEMP] = display indicates the current medium temperature in °F.▶ Select [diS] and determine the update rate and orientation of the display:<ul style="list-style-type: none">- [d1] = update of the measured values every 500 ms.- [d2] = update of the measured values every 1000 ms.- [d3] = update of the measured values every 2000 ms.- [rd1], [rd2], [rd3] = display as for d1, d2, d3; rotated by 180°.- [OFF] = the display is switched off in the operating mode.	
---	---

10.5.3 Setting the output logic

▶ Select [P-n] and set [PnP] or [nPn].	<i>P--n</i>
--	-------------

10.5.4 Setting the start-up delay

▶ Select [dSt] and set the numerical value in seconds.	<i>dSt</i>
--	------------

10.5.5 Setting the damping of the measured values

▶ Select [dAP] and the damping constant in seconds (t value 63 %).	<i>dAP</i>
--	------------

10.5.6 Setting the error behavior of OUT1 / OUT2

<ul style="list-style-type: none">▶ Select [FOU1] and determine the value:<ul style="list-style-type: none">- [On] = output 1 switches ON in case of an error.- [OFF] = output 1 switches OFF in case of an error.- [OU] = output 1 switches irrespective of the error as defined with the parameters.▶ Select [FOU2] and determine the value:<ul style="list-style-type: none">- [On] = output 2 switches ON in case of an error, the analog signal goes to the upper end stop value.- [OFF] = output 2 switches OFF in case of an error, the analog signal goes to the lower end stop value.- [OU] = output 2 switches irrespective of the error as defined with the parameters. The analog signal corresponds to the measured value.	<i>FOU1 FOU2</i>
--	----------------------

10.6 Service functions

10.6.1 Reading the min./max. values for flow rate

<ul style="list-style-type: none">▶ Select [HI] or [LO] and press [Set] briefly. [HI] = maximum value, [LO] = minimum value. Delete memory: <ul style="list-style-type: none">▶ Select [HI] or [LO].▶ Press [Set] and keep it pressed until [----] is displayed.▶ Press [Mode/Enter] briefly. It makes sense to delete the memories as soon as the unit works under normal operating conditions for the first time.	<i>HI LO</i>
---	------------------

10.6.2 Reset all parameters to the factory setting

▶ Select [rES], then press [Set] and keep it pressed until [----] is displayed.

▶ Press [Mode/Enter] briefly.

The factory setting is listed at the end of the instructions (→ 13 Factory setting).

It makes sense to write your own settings in this table before executing the function.

rES

11 Operation

11.1 Reading the process value

The LEDs 1-6 signal which process value is currently displayed.

The process value to be displayed as standard (temperature, flow rate and totalizer) can be preset. → 10.4.3 Configuration of the standard display.

Further process values can be read in addition to the preset standard display:

- ▶ Press [Set] briefly.
- > The LED of the selected process value display is lit and the current process value is displayed.
- > After 15 seconds the display changes to the standard display.

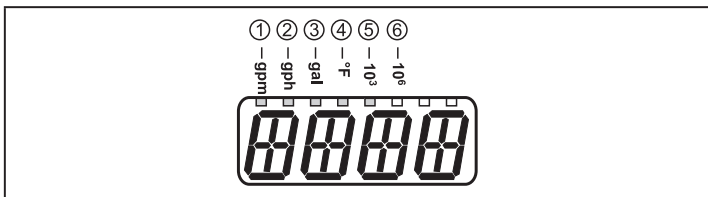

LED	Process value	Unit	
1 □	Current flow process value rate per minute	gpm	
2 □	Current flow process value rate per hour	gph	
3 □	Current volumetric totalizer value since the last reset	gal	
3 𠄎		Volumetric totalizer value before the last reset	gal
3 + 5 □	Totalizer *	Current volumetric totalizer value since the last reset	10 ³ gal
3 + 5 𠄎		Volumetric totalizer value before the last reset	10 ³ gal
3 + 6 □	Current volumetric totalizer value since the last reset	10 ⁶ gal	
3 + 6 𠄎		Volumetric totalizer value before the last reset	10 ⁶ gal
4 □	Current medium temperature	°F	

□ LED is lit; 𠄎 LED flashes

* The volumetric totalizer value is automatically displayed in the unit of measurement providing the highest accuracy.

11.2 Reading the parameter value

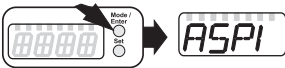
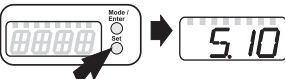
Select parameter ▶ Press [Mode/Enter] until the requested parameter is displayed.	
Display the parameter value ▶ Press [Set] briefly. > The unit displays the corresponding parameter value for approx. 15 s. Then the unit returns to the Run mode.	

11.3 Error indications

	Warning message
[SC1]	Short circuit in OUT1. LED8 for OUT1 flashes (→ 7 Operating and display elements).
[SC2]	Short circuit in OUT2. LED7 for OUT2 flashes (→ 7 Operating and display elements).
[SC]	Short circuit in both outputs. LED7 and LED8 flash (→ 7 Operating and display elements).
[OL]	Detection zone of flow rate or temperature exceeded. Measured value between 120 % and 130 % of the final value of the measuring range.
[UL]	Below the detection zone of flow rate or temperature. Measured value between -120 % and -130 % of the final value of the measuring range.
[Err]	<ul style="list-style-type: none">• Unit faulty / malfunction.• Measured value greater than 130 % of the final value of the measuring range.• Measured value lower than -130 % of the final value of the measuring range.
[Loc]	Setting pushbuttons locked, parameter change rejected.

12 Technical data

Technical data and scale drawing at www.automationdirect.com.

13 Factory setting

		FMM50 - 1001	FMM75 - 1001	FMM100 - 1001	User setting
SP1 (FLOW)	[gpm]	1.5	3	6	
rP1 (FLOW)	[gpm]	1.47	2.94	5.85	
ImPS	[gal]	0.01			
ImPR		YES			
OU1		Hno			
OU2		I			
SP2 (FLOW)	[gpm]	3	6	12	
rP2 (FLOW)	[gpm]	2.96	5.94	11.85	
SP2 (TEMP)	[°F]	77.5			
rP2 (TEMP)	[°F]	77.0			
ASP (FLOW)	[gpm]	0			
AEP (FLOW)	[gpm]	6.6	13.2	26.4	
ASP (TEMP)	[°F]	-4			
AEP (TEMP)	[°F]	176			
DIn2		+EDG			
FOU1		OFF			
FOU2		OFF			
dST	[s]	0			
P-n		PnP			
dAP	[s]	0.6			
rTo		OFF			
diS		d2			
Uni		GPm			
SELd		FLOW			
SEL2		FLOW			

