

MODEL SPT25 PRESSURE TRANSDUCER INSTALLATION & MAINTENANCE SHEET



⚠️ WARNING! READ ⚠️ BEFORE INSTALLATION

1. GENERAL:

A failure resulting in **injury** or **damage** may be caused by excessive overpressure, excessive vibration or pressure pulsation, excessive instrument temperature, corrosion of the pressure containing parts, or other misuse. Consult Automation Direct, Cumming, GA, USA at 1-800-633-0405 before installing if there are any questions or concerns.

2. OVERPRESSURE:

Pressure spikes in excess of the rated overpressure capability of the transducer may cause **irreversible electrical and/or mechanical damage** to the pressure measuring and containing elements.

Fluid hammer and surges can destroy any pressure transducer and must always be avoided. A pressure snubber should be installed to eliminate the damaging hammer effects. Fluid hammer occurs when a liquid flow is suddenly stopped, as with quick closing solenoid valves. Surges occur when flow is suddenly begun, as when a pump is turned on at full power or a valve is quickly opened.

Liquid surges are particularly damaging to pressure transducers if the pipe is originally empty. To avoid damaging surges, fluid lines should remain full (if possible), pumps should be brought up to power slowly, and valves opened slowly. To avoid damage from both fluid hammer and surges, a surge chamber should be installed.

Symptoms of fluid hammer and surge's damaging effects:

- Pressure transducer exhibits an output at zero pressure (large zero offset).
- Pressure transducer output remains constant regardless of pressure
- In severe cases, there will be no output.

ProSense SPT25 Proof & Burst Pressures		
	Proof	Burst
500 psi & below	200% FS	1000% FS
1000-2000 psi	200% FS	500% FS
3000 psi	200% FS	500% FS
5000 psi	150% FS	500% FS

FREEZING:

Prohibit freezing of media in pressure port. Unit should be drained (mount in vertical position with electrical termination upward) to prevent possible overpressure damage from frozen media.

3. STATIC ELECTRICAL CHARGES:

Any electrical device may be susceptible to damage when exposed to static electrical charges. To avoid damage to the transducer observe the following:

- Ground the body of the transducer **BEFORE** making any electrical connections.
- When disconnecting, remove the ground **LAST!**

Note: The shield and drain wire in the cable (if supplied) is not connected to the transducer body, and is not a suitable ground.

DESCRIPTION

The SPT25 pressure transducer is a high performance instrument intended for use in industrial applications where the process media is compatible with the 17-4PH stainless steel sensor material and the 304 SS process connection.

MECHANICAL INSTALLATION

Environmental

The SPT25 transducer can be stored and used within the temperature limits of -40°C to 125°C (-40°F to 257°F). Ingress protection ratings of the units are dependent on the electrical termination specified.

Mounting

The SPT25 transducer requires no special mounting hardware and can be mounted in any orientation with negligible position error. Although the units can withstand considerable vibration without damage or significant output effects, it is always good practice to mount the transducer where there is minimum vibration. For units with NPT type pressure fittings apply sealing tape or an equivalent sealant to the threads before installing. When installing or removing the unit apply a wrench to the hex wrench flats, located above the pressure fitting. **DO NOT** tighten by using a pipe wrench on the housing. A 27mm ($1\frac{1}{8}$ ") wrench can be used on the wrench flats of the hex.

Electro-Magnetic Interference

The circuitry of the SPT25 transducer is designed to minimize the effect of electromagnetic and radio frequency interference. To minimize susceptibility to noise, avoid running the termination wiring in a conduit which contains high current AC power cables. Where possible avoid running the termination wiring near inductive equipment.

Field Adjustments

The SPT25 transducer is precisely calibrated and temperature compensated at the factory to ensure long and stable performance. There are no field accessible adjustments on the SPT25 transducer.

SPT25 ELECTRICAL INSTALLATION

Wiring Diagrams

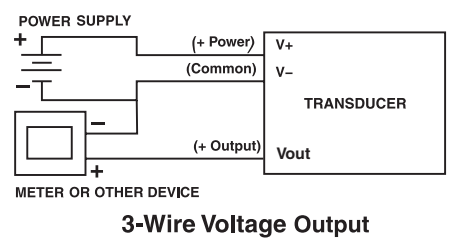
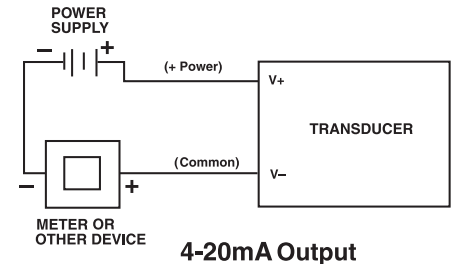

Power Supply Requirements:

Output Signal	Min Supply	Max Supply
0-10V	14Vdc	36Vdc
4-20mA*	9Vdc	36Vdc

*For transmitters with 4-20mA output signal, the minimum voltage at the terminals is 9Vdc. However, the minimum supply voltage should be calculated using the adjacent graph and formula.

MODEL SPT25 PRESSURE TRANSDUCER INSTALLATION & MAINTENANCE SHEET



SPT25 ELECTRICAL INSTALLATION

Power Supply Voltage vs Loop Resistance

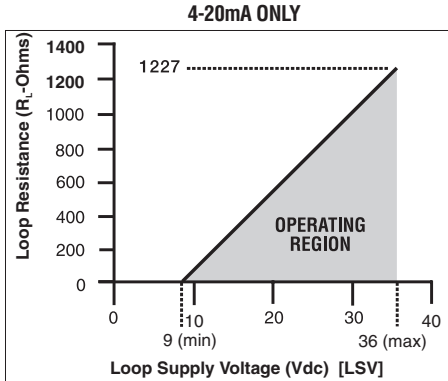

0-10V Output

Minimum resistance: 10,000Ω

SPT25 ELECTRICAL TERMINATIONS AND WIRING

DIN-C Connector

4-20 ma output

- V_{S+} : #1
- V_{S-} : #2

Connection - PIN

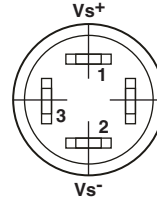

0-10V output

- V_{S+} : #1
- V_{S-} : #2
- V_{OUT} : #3

Connection - PIN

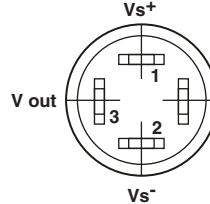

Shielded Cable

PVC JACKET, 24AWG LEADS

Wire Color	Voltage Output	4-20mA Output
Red	V+	V+
Black	Common	V-
White	Output	
Bare	Shield Drain Wire	Shield Drain Wire

IP67 Ingress rating

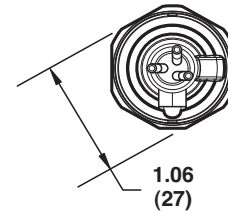

IP 65 Ingress Rating

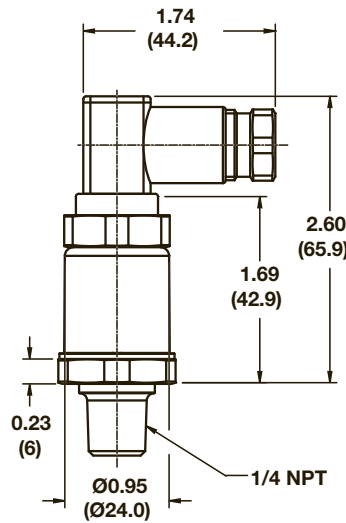

Dimension shown in inches (mm)

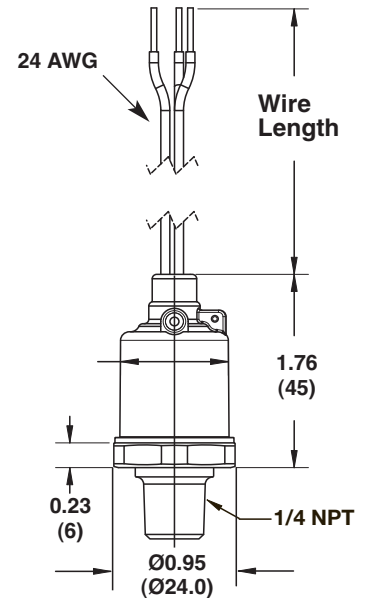

Dimension shown in inches (mm)