

proense[®]

CE

Operating instructions
Electronic digital pressure sensor
EPS25-XXXX-1001

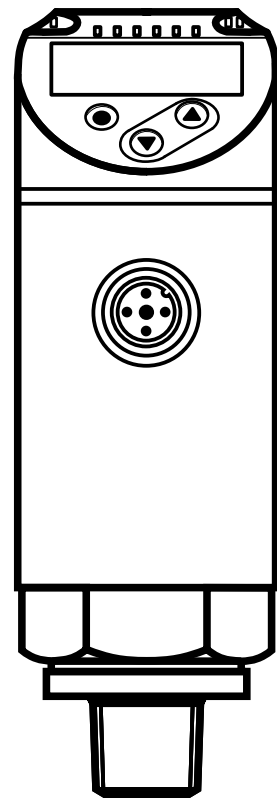

80254563 / 00 06 / 2016



AutomationDirect
3505 HutchinsonRoad
Cumming, GA 30040

Contents

1	Preliminary note.....	4
1.1	Symbols used	4
2	Safety instructions	4
3	Functions and features	5
3.1	Applications	5
4	Function.....	8
4.1	Parameter setting, evaluation.....	8
4.2	Switching function.....	9
4.3	Analog function	10
5	Installation.....	12
6	Electrical connection.....	12
7	Operating and display elements	14
8	Menu.....	15
8.1	Menu structure: main menu.....	15
8.2	Explanation of the menu.....	16
8.2.1	Explanation of the menu level 1	16
8.2.2	Explanation of the menu level 2	16
9	Parameter setting	17
9.1	Parameter setting in general	17
9.2	Configure display (optional).....	19
9.3	Set output signals	20
9.3.1	Set output functions.....	20
9.3.2	Define switching limits for the hysteresis function	20
9.3.3	Define switching limits for the window function	20
9.3.4	Scaling of the analogue value	20
9.4	User settings (optional).....	21
9.4.1	Set delay for the switching outputs.....	21
9.4.2	Set output logic for the switching outputs	21
9.4.3	Set damping for the switching signal	21
9.4.4	Damping for analog output	21
9.4.5	Zero-point calibration.....	21
9.4.6	Read min/max values for the system pressure	21

9.4.7	Reset all parameters to factory setting	22
9.4.8	Set colour change of the display	22
9.4.9	Graphical depiction of the color change of the display	22
10	Operation	25
10.1	Read set parameters	25
10.2	Self-diagnosis / error indications	25
11	Technical data and scale drawing	27
11.1	Setting ranges	27
11.2	Further technical data	29
12	Factory setting	29

1 Preliminary note

1.1 Symbols used

▶ Instructions

> Reaction, result

[...] Designation of keys, buttons or indications

→ Cross-reference



Important note

Non-compliance may result in malfunction or interference



Information

Supplementary note

2 Safety instructions

- Please read this document prior to set-up of the unit. Ensure that the product is suitable for your application without any restrictions.
- If the operating instructions or the technical data are not adhered to, personal injury and/or damage to property can occur.
- Check the compatibility of the product materials with the media to be measured in all applications.
- Correct condition of the device for the operating time can only be guaranteed if the device is only used for media to which the wetted materials are sufficiently resistant → 3.1 Applications.
- If the devices are used in gas applications with pressures > 362 psig (25 bar) the notes in chapter 3.1 for devices with the marking ******), must be absolutely observed!
- For the scope of validity cULus:
The device shall be supplied from an isolating transformer having a secondary Listed fuse rated either
 - a) max 5 amps for voltages 0~20 Vrms (0~28.3 Vp) or
 - b) 100/Vp for voltages of 20~30 Vrms (28.3~42.4 Vp).The device shall be connected only by using any Listed (CYJV/7) or R/C (CYJV2/8) cord in respect of Condition of Acceptability, having suitable ratings



The responsibility whether the measurement device is suitable for the respective application lies with the operator. The manufacturer assumes no liability for consequences of misuse by the operator. Improper installation and use of the devices result in a loss of the warranty claims.

3 Functions and features

The device monitors the system pressure of machines and installations.

3.1 Applications

Type of pressure: Relative pressure

		Measuring Range	Proof Pressure*	Bursting Pressure
EPS25-5800-1001	psig	0...5800	11580	24650
	bar	0...400	800	1700
	MPa	0...40	80	170
EPS25-3620-1001	psig	0...3625	7250	17400
	bar	0...250	500	1200
	MPa	0...25	50	120
EPS25-1450-1001**	psig	0...1450	4350	9400
	bar	0...100	300	650
	MPa	0...10	30	65

		Measuring Range	Proof Pressure*	Bursting Pressure
EPS25-360-1001**	psig	-14.5...362.5	2175	5075
	bar	-1...25	150	350
	MPa	-0.1...2.5	15	35
EPS25-V145-1001**	psig	-14.6...145	1087	2175
	bar	-1...10	75	150
	MPa	-0.1...1	7.5	15
EPS25-36-1001	psig	-1.8...36.25	290	725
	bar	-0.125...2.5	20	50
	kPa	-12.5...250	2000	5000
EPS25-14-1001	psig	-0.72...14.5	145	450
	inH2O	-20...401.5	4000	12040
	mbar	-50...1000	10000	30000
	kPa	-5...100	1000	3000

		Measuring Range	Proof Pressure*	Bursting Pressure
EPS25-V14-1001	psig	-14.5...14.5	145	450
	inH2O	-402...402	4018	12055
	mbar	-1000...1000	10000	30000
	kPa	-100...100	1000	3000
	inHg	-29.5...29.5	295	885
EPS25-100WC-1001	mmWS	-125...2550	102000	306000
	inH2O	-5...100.4	4000	12000
	mbar	-12.5...250	10000	30000
	kPa	-1.25...25	1000	3000

*) With static overload pressure or max. 100 million pressure cycles.

**) For gas applications 362 psig (25 bar) maximum pressure !

MPa = (measured value in bar) ÷ 10

kPa = (measured value in bar) x 100



Avoid static and dynamic overpressure exceeding the proof pressure (specified maximum permissible pressure) by taking appropriate measures.

The indicated bursting pressure must not be exceeded.

Even if the bursting pressure is exceeded only for a short time, the unit may be destroyed. ATTENTION: Risk of injury!



The units are vacuum resistant. EPS25-100WC-1001 can only resistant vacuum of 300 mbar (120inH₂O).



Pressure Equipment Directive (PED): The units comply with the Pressure Equipment Directive and are designed and manufactured for group 2 fluids (Non-Hazardous, Nonflammable, Non-Oxidizing) in accordance with the sound engineering practice.

4 Function

- The unit displays the current system pressure.
- It generates output signals according to the operating mode and the parameter setting.

4.1 Parameter setting, evaluation

OUT1 (pin 4)	<ul style="list-style-type: none">• Switching signal for system pressure limit value
OUT2 (pin 2)	<ul style="list-style-type: none">• Switching signal for system pressure limit value• Analogue signal 4...20 mA / 0...10 V

4.2 Switching function

OUTx changes its switching status if it is above or below the set switching limits (SPx, rPx). The following switching functions can be selected:

- Hysteresis function / normally open: [ou1/ou2] = [Hno] (→ fig. 1).
- Hysteresis function / normally closed: [ou1/ou2] = [Hnc] (→ fig. 1).

First the set point (SPx) is set, then the reset point (rPx).

The hysteresis defined remains even if SPx is changed again.

- Window function / normally open: [ou1/ou2] = [Fno] (→ fig. 2).
- Window function / normally closed: [ou1/ou2] = [Fnc] (→ fig. 2).

The width of the window can be set by means of the difference between FHx and FLx. FHx = upper value, FLx = lower value.

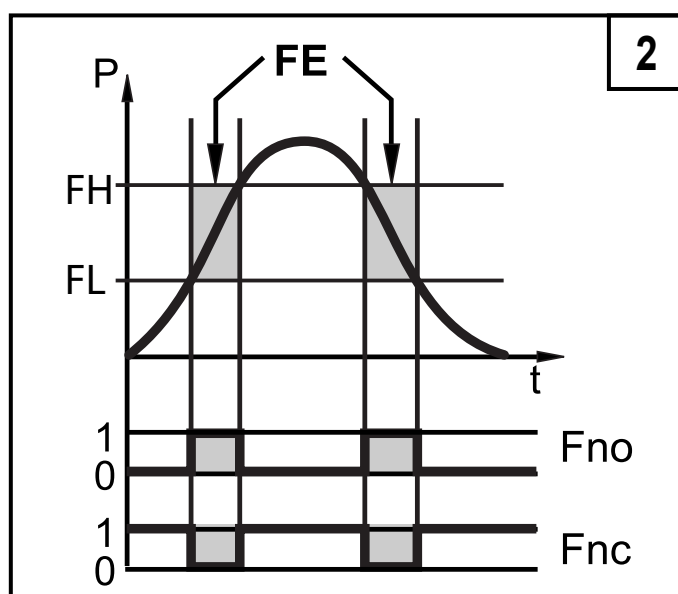
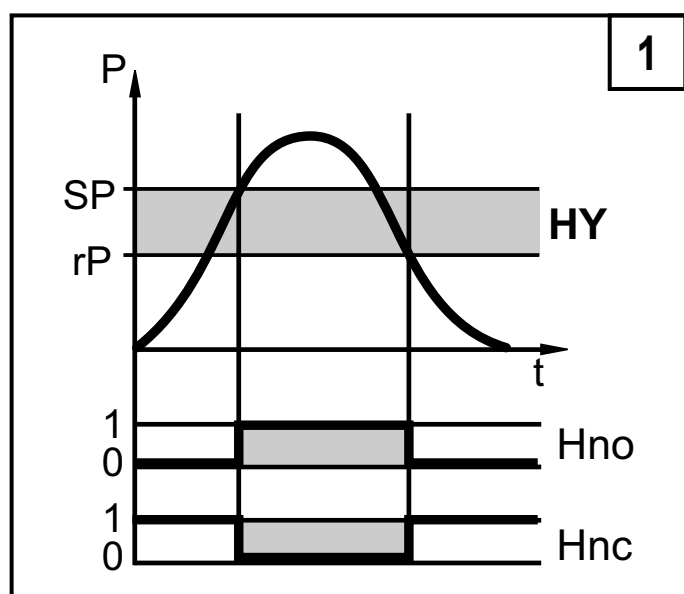

P = system pressure; HY = hysteresis; FE = window



When set to the window function the upper and lower limit values have a fixed hysteresis of 0.25 % of the final value of the measuring span.

4.3 Analog function

OUT2 is an analog output:

- [ou2] defines whether the set measuring range is provided as 4...20 mA ([ou2]= [I]) or as 0...10 V ([ou2] = [U]).
- Analog start point [ASP2] determines at which measured value the output signal is 4 mA or 0 V.
- Analog end point [AEP2] determines at which measured value the output signal is 20 mA or 10 V.

Minimum distance between [ASP2] and [AEP2] = 20 % of the measuring span.

Voltage output 0...10 V:

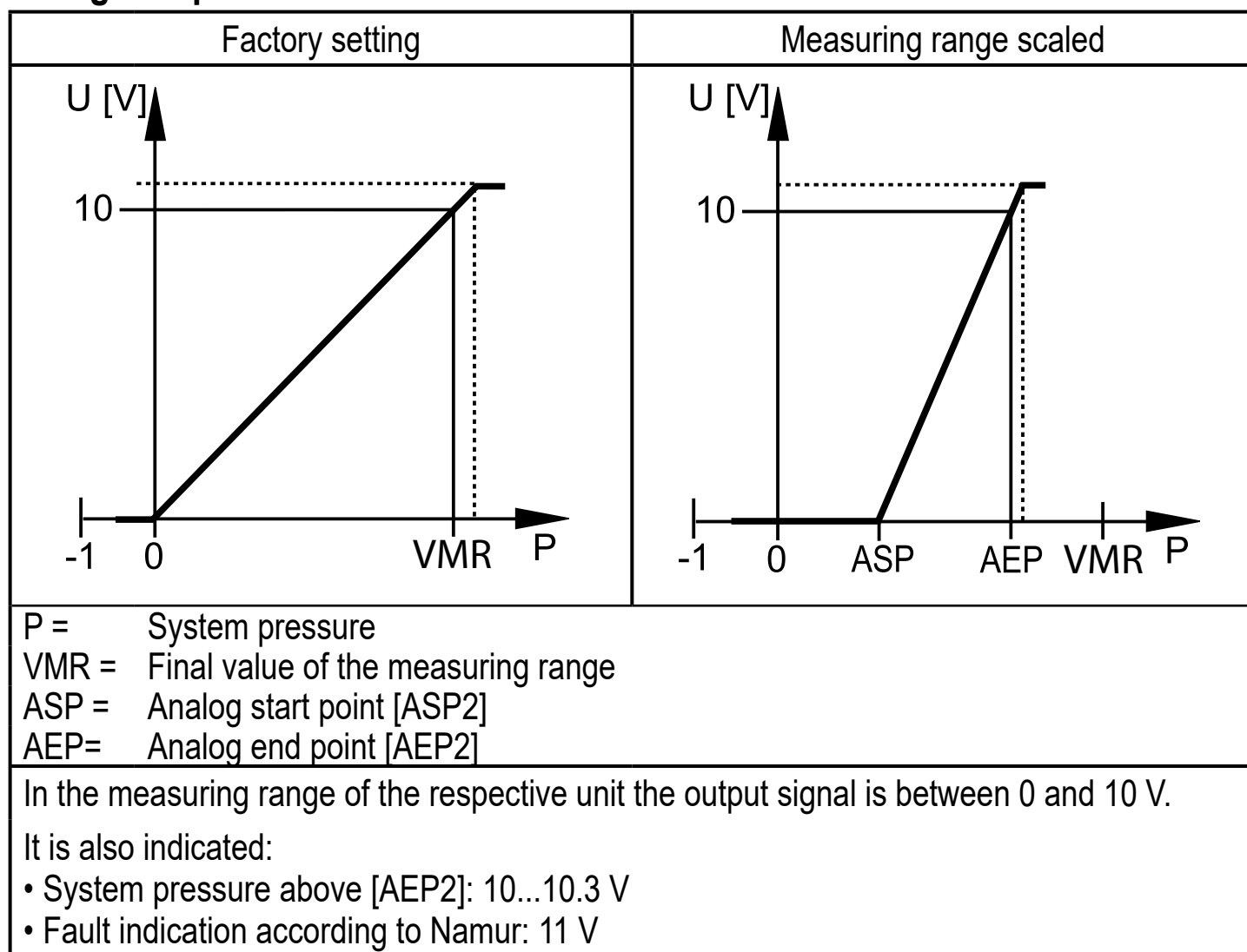

Current output 4...20 mA

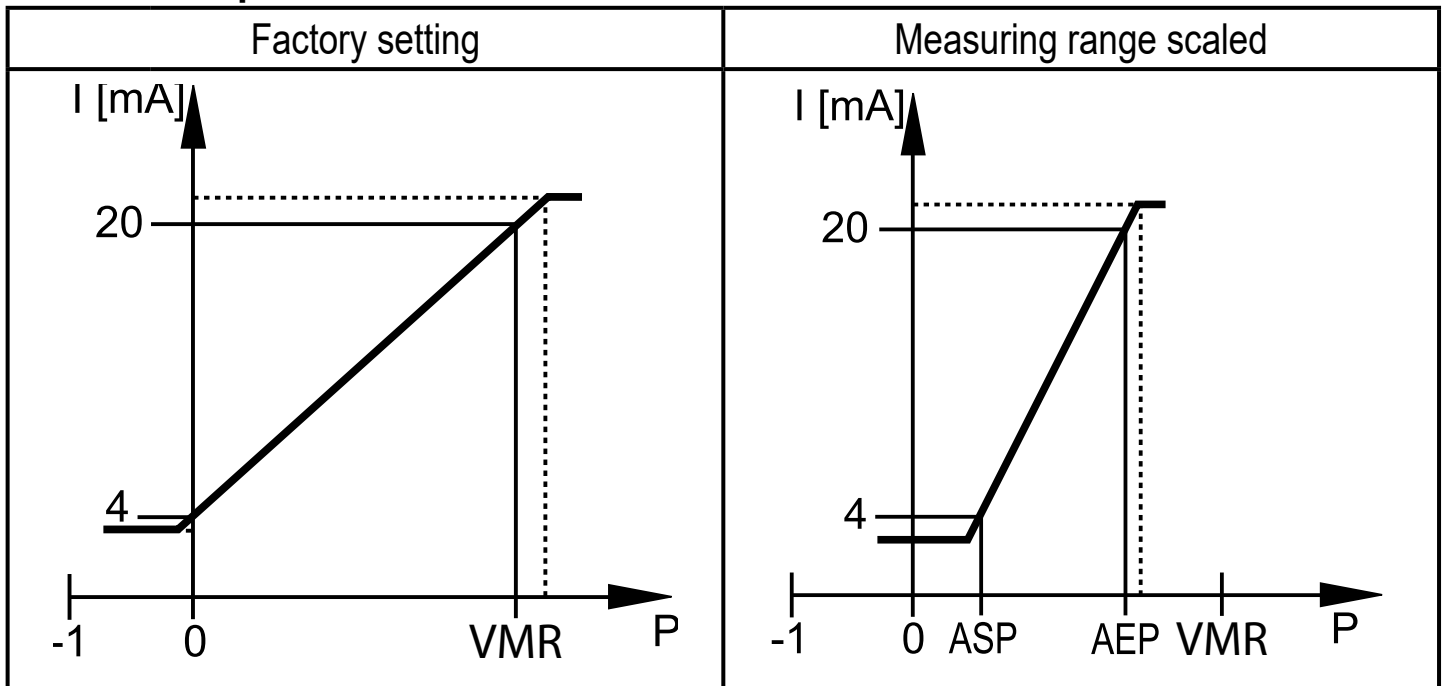

P = System pressure

VMR = Final value of the measuring range

ASP = Analog start point [ASP2]

AEP = Analog end point [AEP2]

In the measuring range, the output signal is between 4 and 20 mA.

It is also indicated:

- System pressure above [AEP2]: 20...20.5 mA
- System pressure below [ASP2]: 4...3.8 mA
- Fault indication according to Namur: 21.5 mA.

5 Installation



Before installing and removing the unit: make sure that no pressure is applied to the system.

- ▶ Insert the unit in a ¼ - 18 NPT process connection.
- ▶ Liquid or paste type thread sealer is not recommend.
If thread sealer is required use a tape type that is compatible with the media.

The sensor housing can be rotated by 345° with regard to the process connection.



Do not rotate past the end stop!

6 Electrical connection



The unit must be connected by a qualified electrician.

The national and international regulations for the installation of electrical equipment must be adhered to.

Voltage supply according to EN 50178, SELV, PELV.



For the scope of validity cULus:

The device shall be supplied from an isolating transformer having a secondary Listed fuse rated either

- a) max 5 amps for voltages 0~20 Vrms (0~28.3 Vp) or
- b) 100/Vp for voltages of 20~30 Vrms (28.3~42.4 Vp).

The device shall be connected only by using any Listed (CYJV/7) or R/C (CYJV2/8) cord in respect of Condition of Acceptability, having suitable ratings.

- ▶ Disconnect power.
- ▶ Connect the unit as follows:

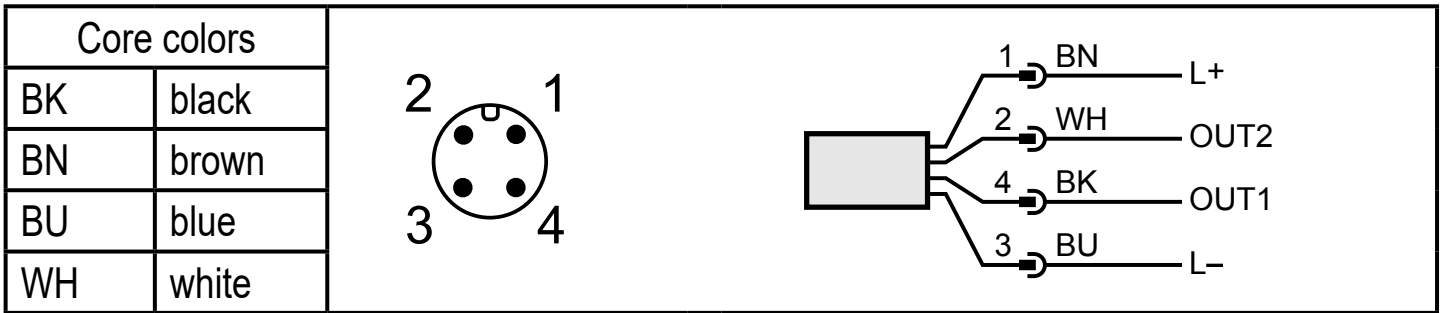

OUT1: switching output
 OUT2: switching outputs or analog output
 Colors to DIN EN 60947-5-2

Example circuit

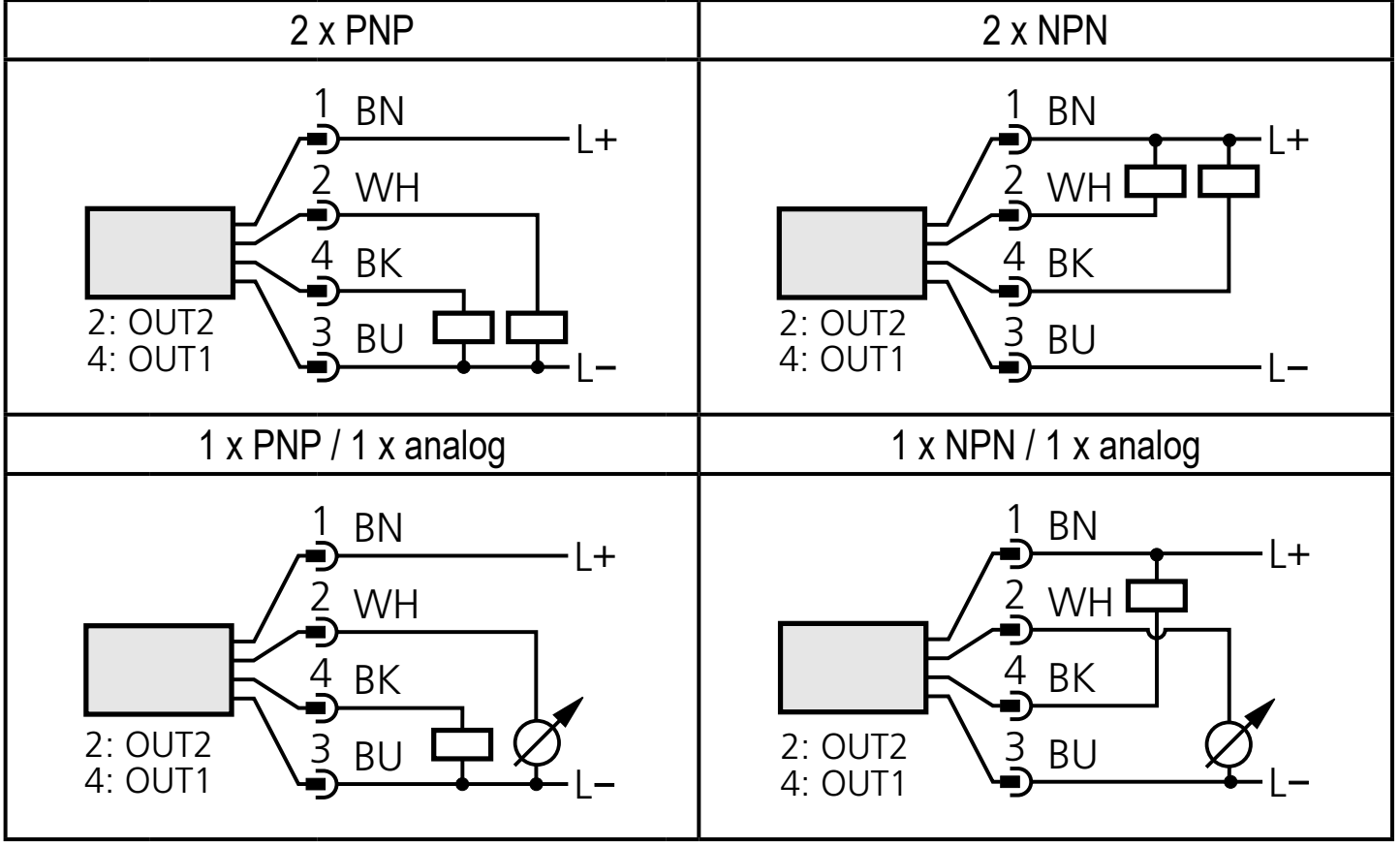

7 Operating and display elements

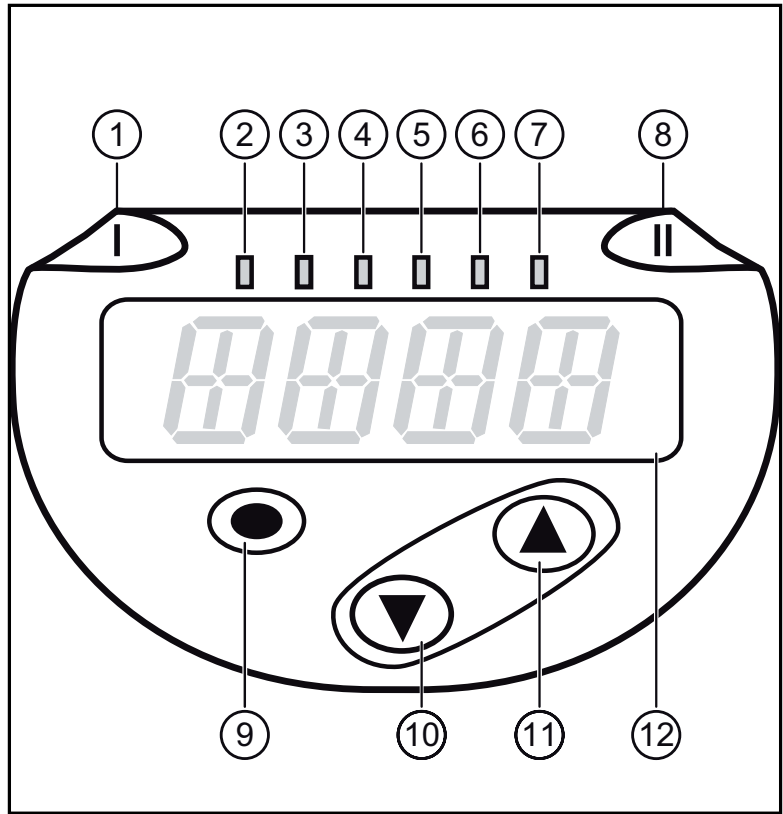

1 to 8: indicator LEDs	
LED 1	Switching status OUT1 (lights when output 1 is switched).
LED 8	Switching status OUT2 (lights when output 2 is switched).
LEDs 2 - 7	System pressure in the indicated unit of measurement
9: Enter button [●]	
- Selection of the parameters and acknowledgement of the parameter values.	
10 to 11: Arrow keys up [▲] and down [▼]	
- Setting of the parameter values (scrolling by holding pressed; incremental by pressing once).	
12: Alphanumeric display, 4 digits	
- Display of the current system pressure.	
- Indication of the parameters and parameter values.	

8 Menu

8.1 Menu structure: main menu

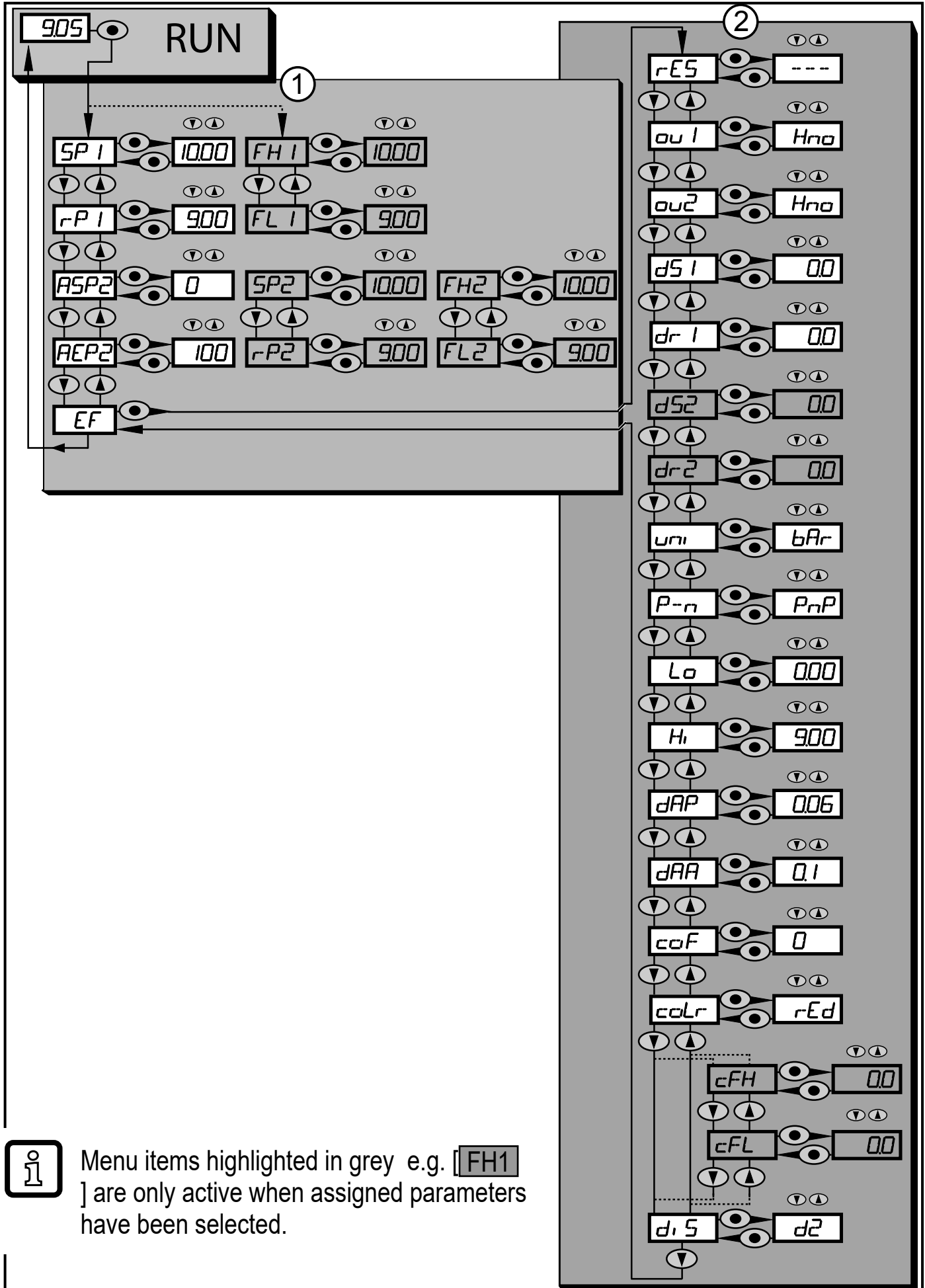

Menu items highlighted in grey e.g. [FH1] are only active when assigned parameters have been selected.

8.2 Explanation of the menu

8.2.1 Explanation of the menu level 1

SPx / rPx	Upper / lower limit value for system pressure at which OUTx switches with hysteresis setting. Prerequisite: OUTx setting is [Hno] or [Hnc].
FHx / FLx	Upper / lower limit value for system pressure at which OUTx switches with window setting. Prerequisite: OUTx setting is [Fno] or [Fnc].
ASP2	Analog start point for system pressure: measured value at which 4 mA / 0 V are provided. Prerequisite: OUT2 setting is [I] or [U].
AEP2	Analog end point for system pressure: measured value at which 20 mA / 10 V are provided. Prerequisite: OUT2 setting is [I] or [U].
EF	Extended functions / opening of menu level 2.

8.2.2 Explanation of the menu level 2

rES	Restore factory setting.
ou1	Output function for OUT1: • Switching signal for the pressure limit values: hysteresis function [H ..] or window function [F ..], either normally open [. no] or normally closed [. nc].
ou2	Output function for OUT2: • Switching signal for the pressure limit values: hysteresis function [H ..] or window function [F ..], either normally open [. no] or normally closed [. nc]. • Analog signal for the current system pressure: 4...20 mA [I] or 0...10 V [U].
dS1 / dS2	Switching delay for OUT1 / OUT2.
dr1 / dr2	Switch-off delay for OUT1 / OUT2.
uni	Standard unit of measurement for system pressure (display): [PSI] / [bAr] / [mbar] / [MPa] / [kPa] / [inHG] / [iH2O] / [mmWS] .
P-n	Output logic: pnp / npn.
Lo	Minimum value memory for system pressure.
Hi	Maximum value memory for system pressure.
dAP	Damping of the switch point.
dAA	Damping of the analog output. Prerequisite: OUT2 setting is [I] or [U].
coF	Zero-point calibration.
coLr	Assignment of the display colors "red" and "green" within the measuring range.
cFH / cFL	Upper / lower value for color change. Parameter only active after selection of a freely definable color window in the coLr parameter: [r-cF] or [G-cF].
diS	Update rate and orientation of the display.

9 Parameter setting

During parameter setting the unit remains in the operating mode. It continues to monitor with the existing parameters until the parameter setting has been completed.

9.1 Parameter setting in general

3 steps must be taken for each parameter setting:

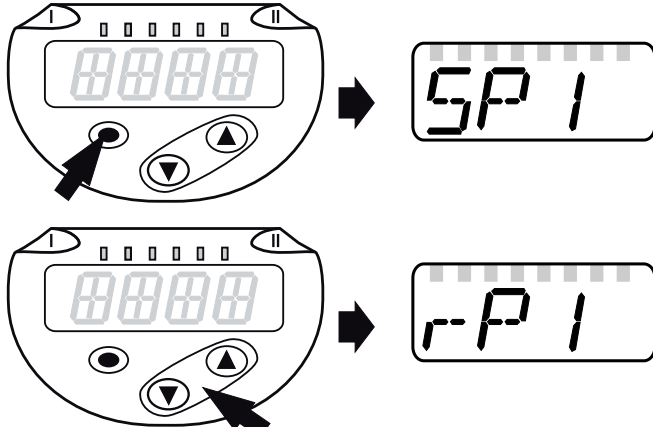
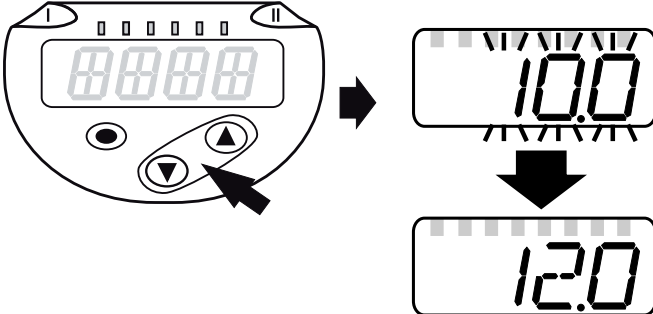
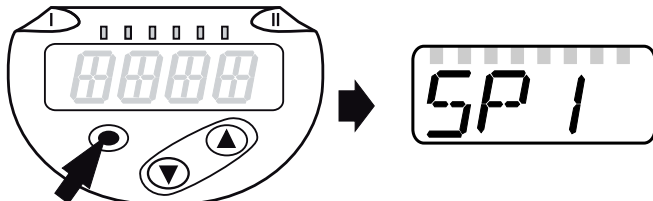
1	Select parameter <ul style="list-style-type: none">▶ Press [●] to get to the menu.▶ Press [▲] or [▼] until the requested parameter is displayed.	
2	Set parameter value <ul style="list-style-type: none">▶ Press [●] to edit the selected parameter.▶ Press [▲] or [▼] for min. 1 s.> After 1 s: setting value is changed: incrementally by pressing the button once or continuously by keeping the button pressed.	
Numerical values are incremented continuously with [▲] or decremented with [▼].		
3	Acknowledge parameter value <ul style="list-style-type: none">▶ Briefly press [●].> The parameter is displayed again. The new setting value is saved.	
Set other parameters <ul style="list-style-type: none">▶ Press [▲] or [▼] until the requested parameter is displayed.		
Finish parameter setting <ul style="list-style-type: none">▶ Press [▲] or [▼] several times until the current measured value is displayed or wait for 30 s.> The unit returns to the process value display.		

- Change from menu level 1 to menu level 2:

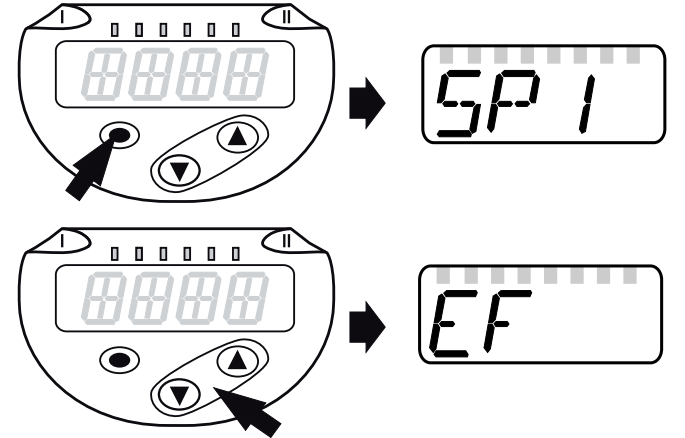
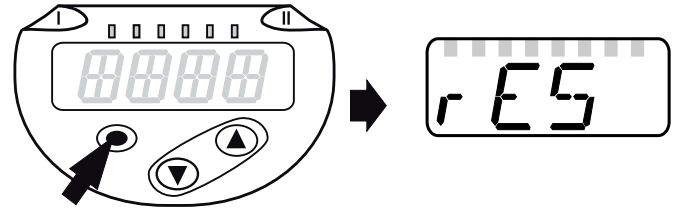
<ul style="list-style-type: none"> ▶ Press [●] to get to the menu. ▶ Press [▲] [▼] until [EF] is displayed. 	
<ul style="list-style-type: none"> ▶ Press [●]. > The first parameter of the submenu is displayed (here: [rES]). 	

- Locking / unlocking

The unit can be locked electronically to prevent unintentional settings.

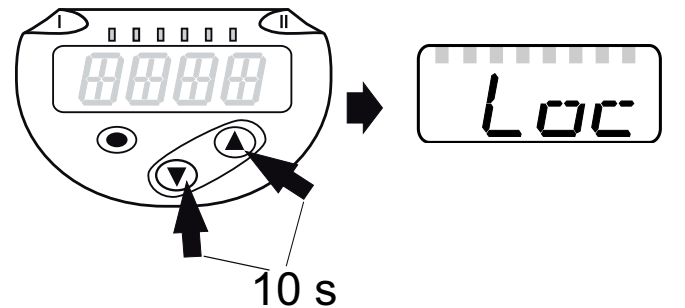
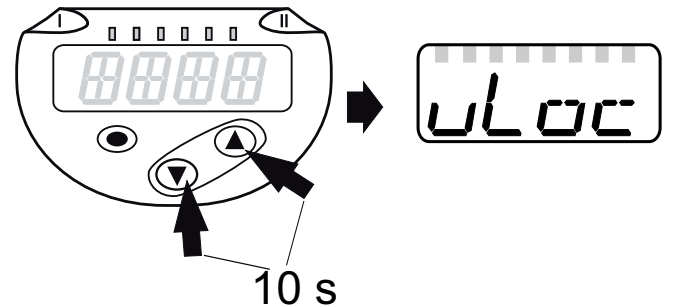
<ul style="list-style-type: none"> ▶ Make sure that the unit is in the normal operating mode. ▶ Press [▲] + [▼] simultaneously for 10 s. > [Loc] is displayed. 	
<p>During operation: [Loc] is briefly displayed if you try to change parameter values.</p>	
<p>For unlocking:</p> <ul style="list-style-type: none"> ▶ Make sure that the unit is in the normal operating mode. ▶ Press [▲] + [▼] simultaneously for 10 s. > [uLoc] is displayed. 	

On delivery: not locked.

- Timeout:

If no button is pressed for 30 s during parameter setting, the unit returns to the operating mode with unchanged values.

- Exit a parameter without adopting the settings

To exit a parameter without adopting the settings:

- ▶ Press [▲] + [▼] simultaneously.
- > Return to the menu level.

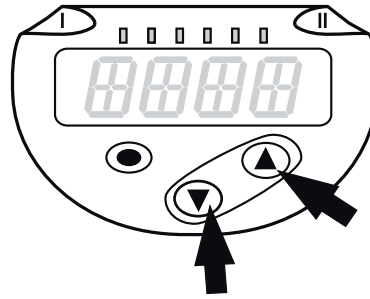

• Leaving the menu level

To leave the menu level:

- ▶ Press [▲] + [▼] simultaneously.
- > Menu level 2 changes to level 1 or level 1 changes to display.

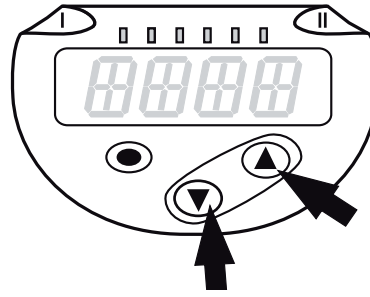

9.2 Configure display (optional)

<ul style="list-style-type: none"> ▶ Select [Uni] and set the unit of measurement: <ul style="list-style-type: none"> - [PSI], - [bAr], [mbAr], - [MPA], [kPA], - [inHG], - [iH2O], - [mmWS] 	
<div style="display: flex; align-items: center;"> <div style="border: 1px solid black; border-radius: 50%; width: 30px; height: 30px; display: flex; align-items: center; justify-content: center; margin-right: 10px;"> i </div> <div> <p>The selectable units of measurement depend on the respective unit.</p> </div> </div>	
<ul style="list-style-type: none"> ▶ Select [diS] and set the update rate and orientation of the display: <ul style="list-style-type: none"> - [d1]: update of the measured values every 50 ms. - [d2]: update of the measured values every 200 ms. - [d3]: update of the measured values every 600 ms. - [rd1], [rd2], [rd3]: display as for d1, d2, d3; rotated by 180°. - [OFF] = The display is switched off in the operating mode. When one of the buttons is pressed, the current measured value is displayed for 30 s. The LEDs remain active even if the display is deactivated. 	
<div style="display: flex; align-items: center;"> <div style="border: 1px solid black; border-radius: 50%; width: 30px; height: 30px; display: flex; align-items: center; justify-content: center; margin-right: 10px;"> i </div> <div> <p>Even with unsteady pressure characteristics [d1] provides optimum readability; the corresponding algorithms are stored.</p> </div> </div>	

9.3 Set output signals

9.3.1 Set output functions

<ul style="list-style-type: none"> ▶ Select [ou1] and set the switching function: <ul style="list-style-type: none"> - [Hno] = hysteresis function/NO, - [Hnc] = hysteresis function/NC, - [Fno] = window function/NO, - [Fnc] = window function/NC. 	ou 1
<ul style="list-style-type: none"> ▶ Select [OU2] and set the analogue function: <ul style="list-style-type: none"> - [Hno] = hysteresis function/NO, - [Hnc] = hysteresis function/NC, - [Fno] = window function/NO, - [Fnc] = window function/NC. - [I] = current signal 4...20 mA, - [U] = voltage signal 0...10 V. 	ou2

9.3.2 Define switching limits for the hysteresis function

<ul style="list-style-type: none"> ▶ [ou1] / [ou2] must be set as [Hno] or [Hnc]. ▶ Select [SPx] and set the value at which the output is set. 	SP 1 SP 2
<ul style="list-style-type: none"> ▶ Select [rPx] and set the value at which the output resets. <p>[rPx] is always smaller than [SPx]. The unit only accepts values which are lower than the value for [SPx].</p>	rP 1 rP 2

9.3.3 Define switching limits for the window function

<ul style="list-style-type: none"> ▶ [ou1] / [ou2] must be set as [Fno] or [Fnc]. ▶ Select [FHx] and set the upper limit value. 	FH 1 FH 2
<ul style="list-style-type: none"> ▶ Select [FLx] and set the lower limit value. <p>[FLx] is always lower than [FHx]. The unit only accepts values which are lower than the value for [FHx].</p>	FL 1 FL 2

9.3.4 Scaling of the analogue value

<ul style="list-style-type: none"> ▶ Select [ASP2] and set the value at which 4 mA / 0 V is provided. 	ASP 2
<ul style="list-style-type: none"> ▶ Select [AEP2] and set the value at which 20 mA / 10 V is provided. <p>Minimum distance between [ASP2] and [AEP2] = 20 % of the measuring span (scaling factor 5).</p>	AEP 2

9.4 User settings (optional)

9.4.1 Set delay for the switching outputs

<p>[dS1] / [dS2] = switching delay for OUT1 / OUT2. [dr1] / [dr2] = reset delay for OUT1 / OUT2.</p> <ul style="list-style-type: none">▶ Select [dS1], [dS2], [dr1] or [dr2] and set a value between 0 and 50 s (at 0 the delay time is not active).	<p>dS1 dr1 dS2 dr2</p>
--	------------------------------------

9.4.2 Set output logic for the switching outputs

<ul style="list-style-type: none">▶ Select [P-n] and set [PnP] or [nPn].	<p>P--n</p>
--	-------------

9.4.3 Set damping for the switching signal

<ul style="list-style-type: none">▶ Select [dAP] and set the damping constant in seconds (value τ: 63 %); setting range 0.000...4.000 s.	<p>dAP</p>
 Damping affects [dAP] the switch point and the display.	

9.4.4 Damping for analog output

<ul style="list-style-type: none">▶ Select [dAA] and set the damping constant (rise time 10...90 %) in seconds; setting range 0.000...4.000 s.	<p>dAA</p>
 Damping [dAA] only affects the analog output	

9.4.5 Zero-point calibration

<ul style="list-style-type: none">▶ Select [coF] and set a value between -5 % and 5 % of the final value of the measuring range (if EPS25-V14-1001 ± 5 % of the measuring span). The internal measured value "0" is shifted by this value.	<p>coF</p>
---	------------



9.4.6 Read min/max values for the system pressure

<ul style="list-style-type: none">▶ Select [HI] or [Lo] and briefly press [●]. [HI] = maximum value, [Lo] = minimum value. Delete memory:▶ Select [HI] or [Lo].▶ Press and hold [▲] or [▼] until [----] is displayed.▶ Briefly press [●].	<p>Hi Lo</p>
--	------------------

9.4.7 Reset all parameters to factory setting

<ul style="list-style-type: none"> ▶ Select [rES]. ▶ Press [●]. ▶ Press and hold [▲] or [▼] until [----] is displayed. ▶ Briefly press [●]. <p>We recommend writing down your own settings before carrying out a reset (→ 12 Factory setting).</p>	
--	---

9.4.8 Set colour change of the display

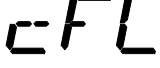
<ul style="list-style-type: none"> ▶ Select [coLr] and set the function: <ul style="list-style-type: none"> - [rEd] = display color red (independent of the measured value). - [GrEn] = display color green (independent of the measured value). - [r1ou] = display color red when OUT1 switches. - [G1ou] = display color green when OUT1 switches. - [r2ou] = display color red when OUT2 switches ([ou2] = [Hxx] / [Fxx]). - [G2ou] = display color green when OUT2 switches ([ou2] = [Hxx] / [Fxx]). - [r-12] = display color red when the measured value is between the limit values of OUT1 and OUT2 ([ou2] = [Hxx] / [Fxx]). - [G-12] = display color green when the measured value is between the limit values of OUT1 and OUT2 ([ou2] = [Hxx] / [Fxx]). - [r-cF] = display color red when the measured value is between the freely definable limit values [cFH]* and [cFL]*. - [G-cF] = display color green when the measured value is between the freely definable limit values [cFH]* and [cFL]*. <p>*) The parameters [cFL] and [cFH] can only be selected in the menu tree when [r-cF] or [G-cF] were activated.</p>	
<ul style="list-style-type: none"> ▶ Select [cFH] and set the upper limit value. (only possible when [r-cF] or [G-cF] were activated). > The setting range corresponds to the measuring range and its minimum limit is [cFL]. 	
<ul style="list-style-type: none"> ▶ Select [cFL] and set the lower limit value (only possible when [r-cF] or [G-cF] were activated). > The setting range corresponds to the measuring range and its maximum limit is [cFH]. 	

9.4.9 Graphical depiction of the color change of the display

Display color change for the parameters [r1ou] / [r2ou] , mode hysteresis function	Display color change for the parameters [G1ou] / [G2ou] , mode hysteresis function
--	--

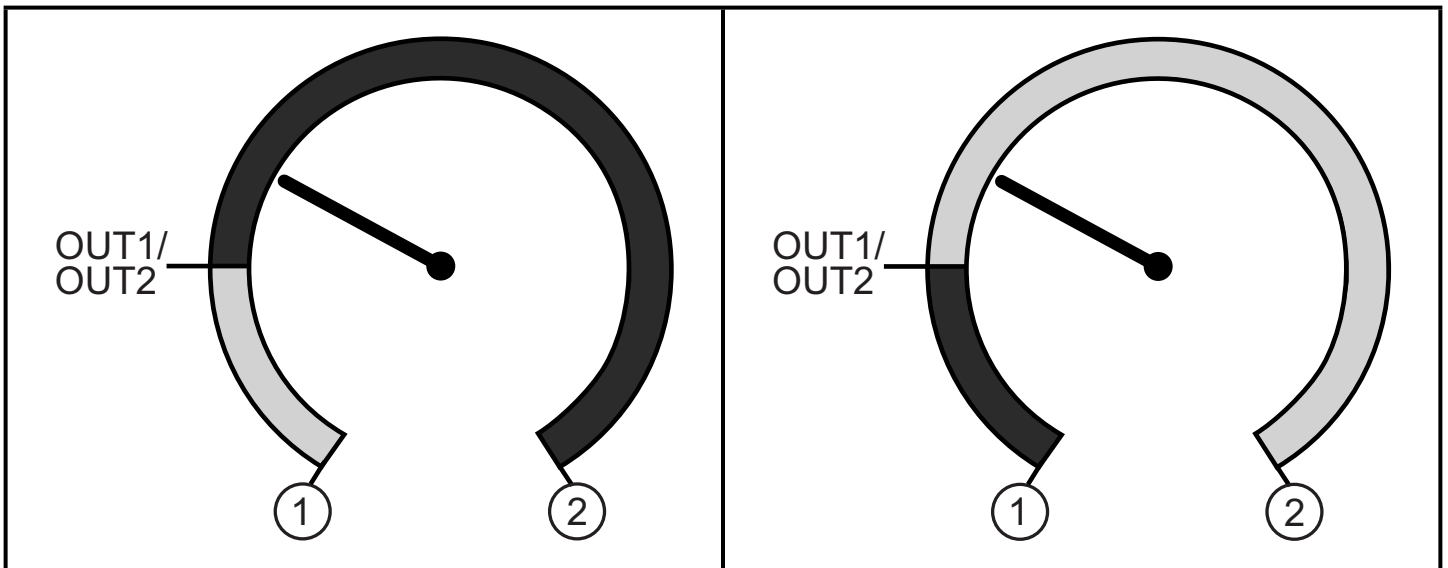

Measured value > switch point OUT1/OUT2;
Display = red

Measured value > switch point OUT1/OUT2;
Display = green

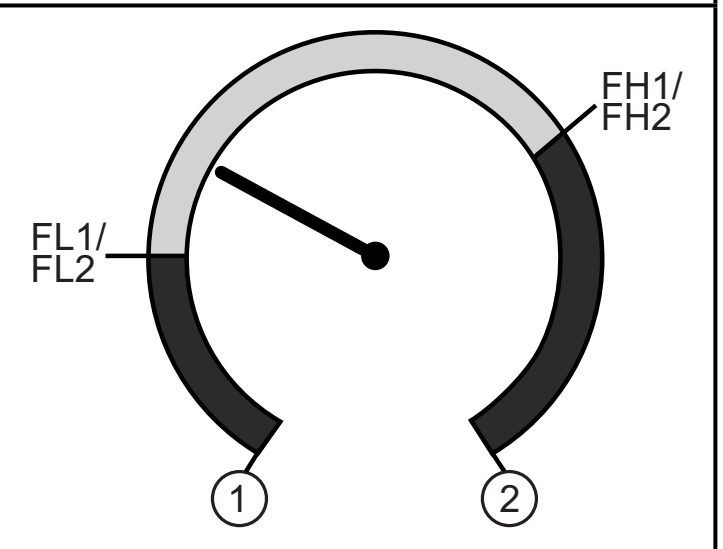
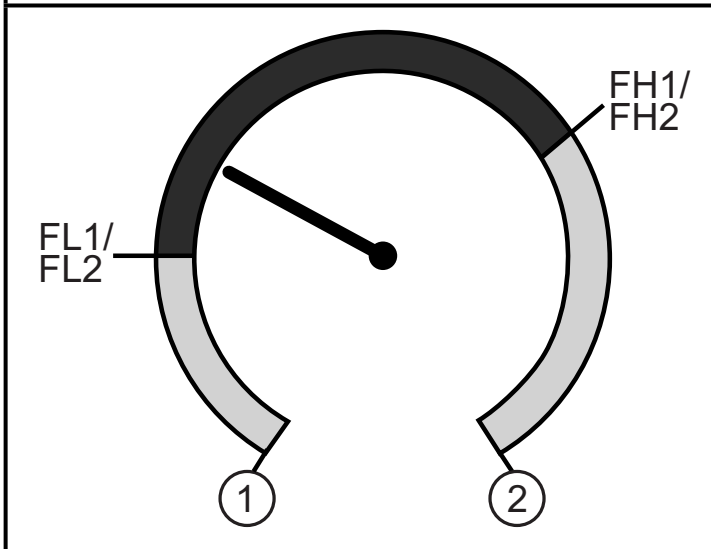

Display color change for the parameters
[r1ou] / [r2ou], mode **window function**

Display color change for the parameters
[G1ou] / [G2ou], mode **window function**



Measured value between FL1/FL2 and
FH1/FH2; Display = red

Measured value between FL1/FL2 and
FH1/FH2; Display = green



	Color change display green
	Color change display red
1	Initial value of the measuring range
2	Final value of the measuring range

 Representation [r-12] / [G-12] only possible when [ou2] = switching output.

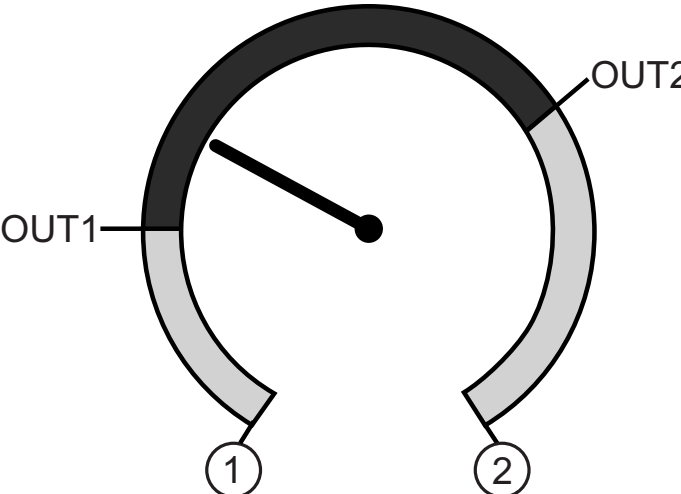
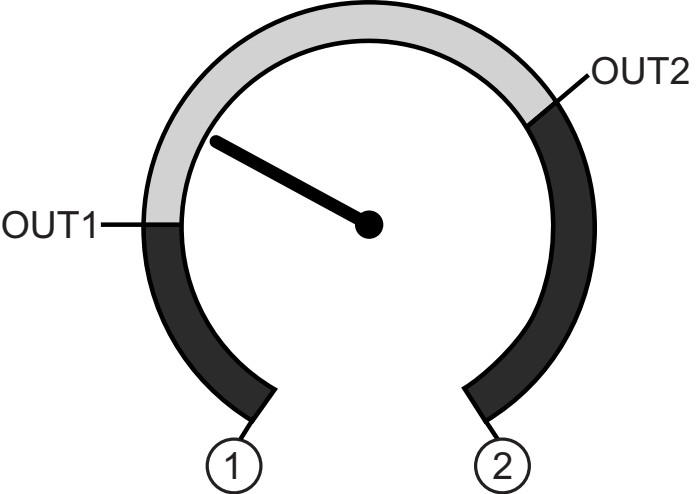
Display color change for the parameters [r-12] , mode hysteresis function	Display color change for the parameters [G-12] , mode hysteresis function
--	--

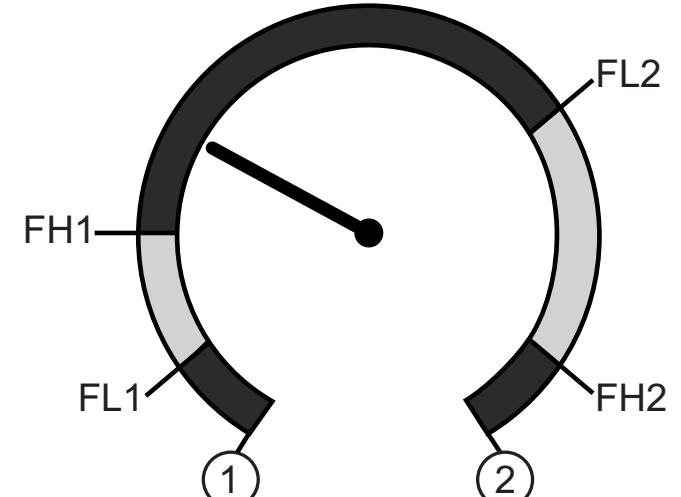
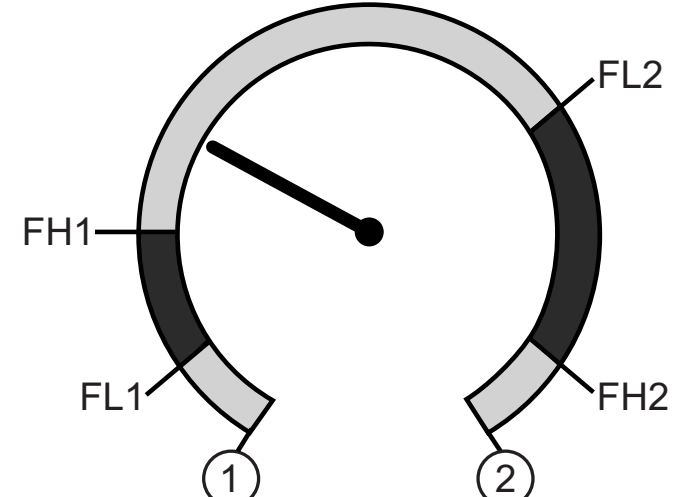

	
<p>Measured value between OUT1 and OUT2; Display = red</p>	<p>Measured value between OUT1 and OUT2; Display = green</p>

<p>Display color change for the parameters [r-12], mode window function</p>	<p>Display color change for the parameters [G-12], mode window function</p>
	
<p>Measured value outside FL1...FH1 and FL2...FH2; Display = red</p>	<p>Measured value outside FL1...FH1 and FL2...FH2; Display = green</p>

	<p>Color change display green</p>
	<p>Color change display red</p>
<p>1</p>	<p>Initial value of the measuring range</p>
<p>2</p>	<p>Final value of the measuring range</p>
<p>FL1 / FL2</p>	<p>Lower limit value window function outputs OUT1 / OUT2</p>
<p>FH1 / FH2</p>	<p>Upper limit value window function outputs OUT1 / OUT2</p>

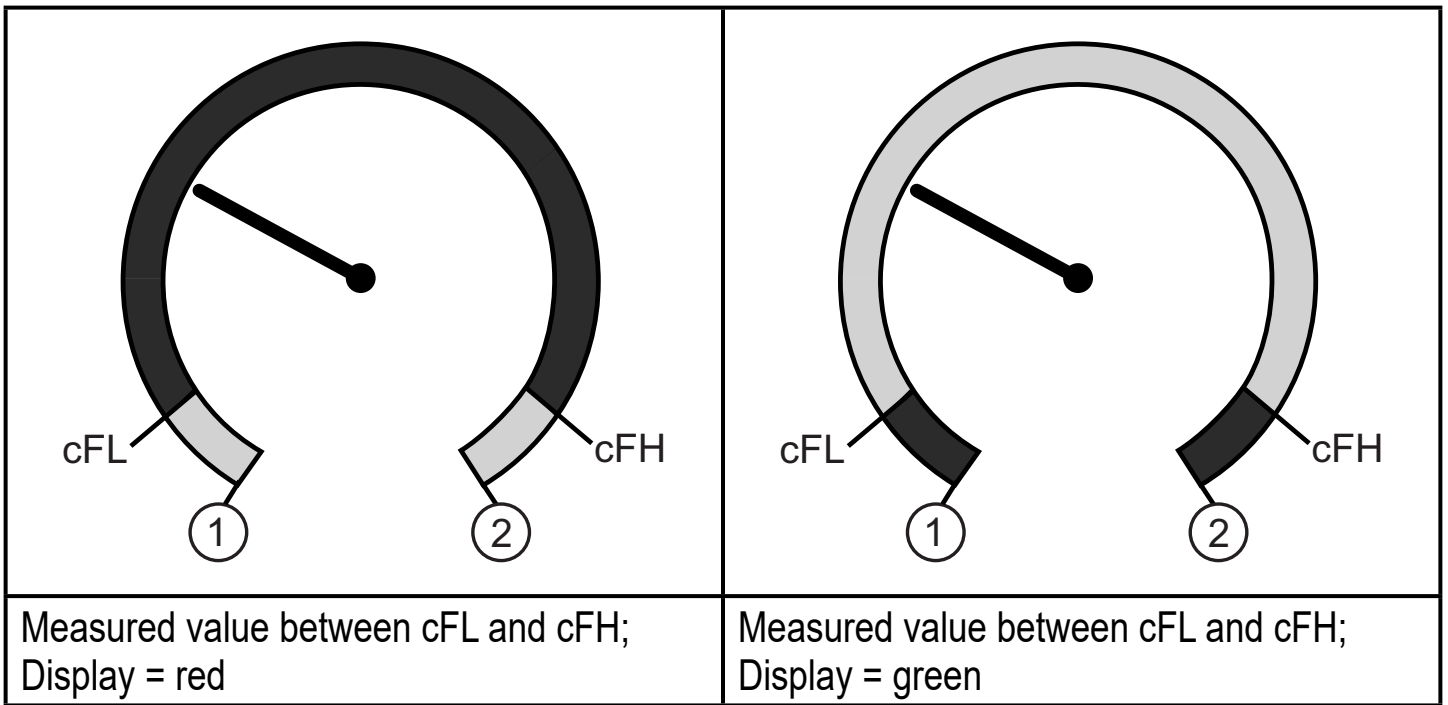
<p>Display color change with parameter [r-cF] independent of OUT1.</p>	<p>Display color change with parameter [G-cF] independent of OUT1.</p>
---	---



	Color change display green
	Color change display red
1	Initial value of the measuring range
2	Final value of the measuring range
cFL	Lower limit value (independent of the output function)
cFH	Upper limit value (independent of the output function)

10 Operation

After power on, the unit is in the Run mode (= normal operating mode). It carries out its measurement and evaluation functions and provides output signals according to the set parameters.

Operation indication → 7 Operating and display elements.

10.1 Read set parameters

- ▶ Press [●].
- ▶ Press [▲] or [▼] until the requested parameter is displayed.
- ▶ Briefly press [●].
- > The unit displays the corresponding parameter value for approx. 30 s; then it changes to the process value display.

10.2 Self-diagnosis / error indications

The unit has many self-diagnostic options.

- It monitors itself automatically during operation.
- Warnings and faults are displayed (even if the display is deactivated).

Display	Status LED OUT1	Status LED OUT2	Fault / warning	Corrective measures
none			Supply voltage too low.	▶ Check / correct the supply voltage.
SC flashes	flashes	flashes	Excessive current at switching outputs OUT1 and OUT2 **).	▶ Check switching outputs for short-circuit or excessive current; remove the fault.
SC1 flashes	flashes		Excessive current at switching output OUT1 **).	▶ Check switching output OUT1 for short-circuit or excessive current; remove the fault.
SC2 flashes		flashes	Excessive current at switching output OUT2 **).	▶ Check switching output OUT2 for short-circuit or excessive current; remove the fault.
Loc			Parameter setting locked via pushbuttons	▶ Unlock buttons → 9.1 Parameter setting in general → "Locking / unlocking".
OL			Process value too high (measuring range exceeded).	▶ Check / reduce system pressure / select unit with corresponding measuring range.
UL			Process value too low (value below measuring range).	▶ Check / increase system pressure / select unit with corresponding measuring range.
Err flashes			Internal fault / malfunction.	▶ Contact the manufacturer.

***) The respective output remains deactivated as long as the excessive current / short circuit continues.

11 Technical data and scale drawing

11.1 Setting ranges

		SP		rP		ASP2		AEP2		cFH		cFL		ΔP
		min	max	min	max	min	max	min	max	min	max	min	max	
EPS25-5800-1001	psig	40	5800	10	5780	0	4640	1160	5800	20	5800	0	5780	10
	bar	2.5	400	1	398.5	0	320	80	400	1.5	400	0	398.5	0.5
	MPa	0.25	40	0.1	39.85	0	32	8	40	0.15	40	0.0	39.85	0.05
EPS25-3620-1001	psig	25	3625	10	3610	0	2900	725	3625	15	3625	0	3610	5
	bar	1.5	250	0.5	249	0	200	50	250	1	250	0	249	0.5
	MPa	0.15	25	0.05	24.9	0	20	5	25	0.1	25	0.0	24.9	0.05
EPS25-1450-1001	psig	10	1450	4	1444	0	1160	290	1450	6	1450	0	1444	2
	bar	0.6	100	0.2	99.6	0	80	20	100	0.4	100	0	99.6	0.2
	MPa	0.06	10	0.02	9.96	0	8	2	10	0.04	10	0	9.96	0.02
EPS25-360-1001	psig	-12	362.5	-13.5	361	-14.5	290	58	362.5	-13	362.5	-14.5	361	0.5
	bar	-0.85	25	-0.95	24.9	-1	20	4	25	-0.9	25	-1	24.9	0.05
	MPa	-0.085	2.5	-0.095	2.49	-0.1	2	0.4	2.5	-0.09	2.5	-0.1	2.49	0.005
EPS25-V145-1001	psig	-13.6	145	-14.2	144.4	-14.6	116	14.6	145	-13.8	145	-14.6	144.4	0.2
	bar	-0.94	10	-0.98	9.96	-1	8	1	10	-0.96	10	-1	9.96	0.02
	MPa	-0.094	1	-0.098	0.996	-0.1	0.8	0.1	1	-0.096	1	-0.1	0.996	0.002

ΔP = in steps of

		SP		rP		ASP2		AEP2		cFH		cFL		ΔP
		min	max	min	max	min	max	min	max	min	max	min	max	
EPS25-36-1001	psig	-1.6	36.25	-1.75	36.1	-1.8	29	5.45	36.25	-1.65	36.25	-1.8	36.1	0.05
	bar	-0.11	2.5	-0.12	2.49	-0.125	2	0.375	2.5	-0.115	2.5	-0.125	2.49	0.005
	kPa	-11	250	-12	249	-12.5	200	37.5	250	-11.5	250	-12.5	249	0.5
EPS25-14-1001	psig	-0.64	14.5	-0.7	14.44	-0.72	11.6	2.18	14.5	-0.66	14.5	-0.72	14.44	0.02
	mbar	-44	1000	-48	996	-50	800	150	1000	-46	1000	-50	996	2
	kPa	-4.4	100	-4.8	99.6	-5	80	15	100	-4.6	100	-5	99.6	0.2
	inH2O	-17.5	401.5	-19	400	-20	321	60.5	401.5	-18.5	401.5	-20	400	0.5
EPS25-V14-1001	psig	-14.3	14.5	-14.45	14.4	-14.5	8.7	-8.7	14.5	-14.4	14.5	-14.5	14.4	0.05
	mbar	-985	1000	-995	990	-1000	600	-600	1000	-990	1000	-1000	990	5
	kPa	-98.5	100	-99.5	99	-100	60	-60	100	-99	100	-100	99	0.5
	inH2O	-396	402	-400	398	-402	240	-240	402	-398	402	-402	398	2
	inHg	-29.2	29.5	-29.4	29.3	-29.5	17.7	-17.7	29.5	-29.3	29.5	-29.5	29.3	0.1
EPS25-100WC-1001	inH2O	-4.4	100.4	-4.8	100	-5	80.2	15	100.4	-4.6	100.4	-5	100	0.2
	mbar	-11	250	-12	249	-12.5	200	37.5	250	-11.5	250	-12.5	249	0.5
	mmWS	-110	2550	-120	2540	-125	2040	385	2550	-115	2550	-125	2540	5
	kPa	-1.1	25	-1.2	24.9	-1.25	20	3.75	25	-1.15	25	-1.25	24.9	0.05

ΔP = in steps of

11.2 Further technical data



Further technical data and scale drawing at:

www.automationdirect.com

12 Factory setting

	Factory setting	User setting
SP1	25% VMR***	
rP1	23% VMR***	
ou1	Hno	
ou2	I	
SP2	75% VMR***	
rP2	73% VMR***	
ASP2	0 (EPS24-V14-1001: -14.4 psig)	
AEP2	100% VMR *	
coF	0	
dSx	0.0	
drx	0.0	
P-n	PnP	
dAP	0.06	
dAA	0.1	
diS	d2	
uni	PSI / IH2O	
coLr	rEd	
cFH	VMR*	
cFL	MAW**	

* = Final value of the measuring range (VMR)

** = Initial value of the measuring range (MAW)

*** = The indicated percentage of the final value of the measuring range (VMR) of the respective sensor in psig (for EPS25-V14-1001 the percentage of the measuring span) is set.

More information at www.automationdirect.com

