

ProSense Bar Graph Panel Meter

DPM3-B-AT-A4R INSTRUCTION MANUAL

TCD260008AA



Read and understand the instruction manual thoroughly before using the product.

For your safety, read and follow the below safety considerations before using.

For your safety, read and follow the considerations written in the instruction manual and AutomationDirect.com website.

Keep this instruction manual in a place where you can find easily.

The specifications, dimensions, etc. are subject to change without notice for product improvement.

Safety Considerations

- Observe all 'Safety Considerations' for safe and proper operation to avoid hazards.
- Symbol indicates caution due to special circumstances in which hazards may occur.

Warning Failure to follow instructions may result in serious injury or death

01. Fail-safe device must be installed when using the unit with machinery that may cause serious injury or substantial economic loss.(e.g. nuclear power control, medical equipment, ships, vehicles, railways, aircraft, combustion apparatus, safety equipment, crime/disaster prevention devices, etc.) Failure to follow this instruction may result in personal injury, economic loss or fire.

02. Do not use or store the unit in the place where flammable/explosive/corrosive gas, high humidity, direct sunlight, radiant heat, vibration, impact or salinity may be present. Failure to follow this instruction may result in explosion or fire.

03. Install on a device panel to use. Failure to follow this instruction may result in fire or electric shock.

04. Do not connect, repair, or inspect the unit while connected to a power source. Failure to follow this instruction may result in fire or electric shock.

05. Check 'Connections' before wiring. Failure to follow this instruction may result in fire.

06. Do not disassemble or modify the unit. Failure to follow this instruction may result in fire or electric shock.

Caution Failure to follow instructions may result in injury or product damage

01. Use the unit within the rated specifications. Failure to follow this instruction may result in fire or product damage

02. Use a dry cloth to clean the unit, and do not use water or organic solvent. Failure to follow this instruction may result in fire or electric shock.

03. Keep the product away from metal chip, dust, and wire residue which flow into the unit. Failure to follow this instruction may result in fire or product damage.

04. Check the polarity of the measurement input before wiring. Failure to follow this instruction may result in explosion or fire.

Caution Failure to follow instructions may result in injury or product damage

01. Use the unit within the rated specifications. Failure to follow this instruction may result in fire or product damage

02. Use a dry cloth to clean the unit, and do not use water or organic solvent. Failure to follow this instruction may result in fire or electric shock.

03. Keep the product away from metal chip, dust, and wire residue which flow into the unit. Failure to follow this instruction may result in fire or product damage.

04. Check the polarity of the measurement input before wiring. Failure to follow this instruction may result in explosion or fire.

Caution Failure to follow instructions may result in injury or product damage

01. Use the unit within the rated specifications. Failure to follow this instruction may result in fire or product damage

02. Use a dry cloth to clean the unit, and do not use water or organic solvent. Failure to follow this instruction may result in fire or electric shock.

03. Keep the product away from metal chip, dust, and wire residue which flow into the unit. Failure to follow this instruction may result in fire or product damage.

04. Check the polarity of the measurement input before wiring. Failure to follow this instruction may result in explosion or fire.

Caution Failure to follow instructions may result in injury or product damage

01. Use the unit within the rated specifications. Failure to follow this instruction may result in fire or product damage

02. Use a dry cloth to clean the unit, and do not use water or organic solvent. Failure to follow this instruction may result in fire or electric shock.

03. Keep the product away from metal chip, dust, and wire residue which flow into the unit. Failure to follow this instruction may result in fire or product damage.

04. Check the polarity of the measurement input before wiring. Failure to follow this instruction may result in explosion or fire.

Caution Failure to follow instructions may result in injury or product damage

01. Use the unit within the rated specifications. Failure to follow this instruction may result in fire or product damage

02. Use a dry cloth to clean the unit, and do not use water or organic solvent. Failure to follow this instruction may result in fire or electric shock.

03. Keep the product away from metal chip, dust, and wire residue which flow into the unit. Failure to follow this instruction may result in fire or product damage.

04. Check the polarity of the measurement input before wiring. Failure to follow this instruction may result in explosion or fire.

Caution Failure to follow instructions may result in injury or product damage

01. Use the unit within the rated specifications. Failure to follow this instruction may result in fire or product damage

02. Use a dry cloth to clean the unit, and do not use water or organic solvent. Failure to follow this instruction may result in fire or electric shock.

03. Keep the product away from metal chip, dust, and wire residue which flow into the unit. Failure to follow this instruction may result in fire or product damage.

04. Check the polarity of the measurement input before wiring. Failure to follow this instruction may result in explosion or fire.

Caution Failure to follow instructions may result in injury or product damage

01. Use the unit within the rated specifications. Failure to follow this instruction may result in fire or product damage

02. Use a dry cloth to clean the unit, and do not use water or organic solvent. Failure to follow this instruction may result in fire or electric shock.

03. Keep the product away from metal chip, dust, and wire residue which flow into the unit. Failure to follow this instruction may result in fire or product damage.

04. Check the polarity of the measurement input before wiring. Failure to follow this instruction may result in explosion or fire.

Caution Failure to follow instructions may result in injury or product damage

01. Use the unit within the rated specifications. Failure to follow this instruction may result in fire or product damage

02. Use a dry cloth to clean the unit, and do not use water or organic solvent. Failure to follow this instruction may result in fire or electric shock.

03. Keep the product away from metal chip, dust, and wire residue which flow into the unit. Failure to follow this instruction may result in fire or product damage.

04. Check the polarity of the measurement input before wiring. Failure to follow this instruction may result in explosion or fire.

Caution Failure to follow instructions may result in injury or product damage

01. Use the unit within the rated specifications. Failure to follow this instruction may result in fire or product damage

02. Use a dry cloth to clean the unit, and do not use water or organic solvent. Failure to follow this instruction may result in fire or electric shock.

03. Keep the product away from metal chip, dust, and wire residue which flow into the unit. Failure to follow this instruction may result in fire or product damage.

04. Check the polarity of the measurement input before wiring. Failure to follow this instruction may result in explosion or fire.

Specifications		
Model	DPM3-B-AT-A4R-H	DPM3-B-AT-A4R-L
Power supply	100-240 VAC ~ 50/60 Hz	24 VDC
Permissible voltage range	90 to 110 % of rated voltage	
Power consumption	≤ 6 VA	≤ 4 W
Sampling period	• TC, RTD: 250 ms • Analog: 100 ms	
Input specification	Refer to 'Input Type and Using Range.'	
Digital input	Contact	• ON: ≤ 2 kΩ • OFF: ≥ 90 kΩ
	Non contact	• Residual voltage: ≤ 1.0 V • Leakage current: ≤ 0.03 mA
	Outflow current	≈ 0.2 mA
Option output	Alarm	4 point relay: 250 VAC ~ 1 A 1a
	PV trans.	ISOLATED DC 4-20 mA (Load resistance: ≤ 600 Ω)
Display type	7 Segment (red), Bar graph (green)	
Alarm output Hysteresis	1 to 999 digit	
Relay life cycle	Mechanical	4 point: ≥ 20,000,000 operations
	Electrical	4 point: ≥ 500,000 operations (load resistance: 250 VAC ~ 1 A)
Dielectric strength	Between the charging part and the case: 2,000 VAC ~ 50/60 Hz for 1 min	
Vibration	0.75 mm amplitude at frequency of 5 to 55 Hz in each X, Y, Z direction for 2 hours	
Insulation resistance	≥ 100 MΩ (500 VDC = megger)	
Noise immunity	± 2 kV square shaped noise (pulse width 1 μs) by noise simulator	
Memory retention	≈ 10 years (non-volatile semiconductor memory type)	
Ambient temperature	-10 to 50 °C, storage: -20 to 60 °C (no freezing or condensation)	
Ambient humidity	35 to 85%RH, storage: 35 to 85%RH (no freezing or condensation)	
Certification	CE	
Unit weight (packaged)	≈ 182 g (≈ 304 g)	

Input Type and Using Range

Input type	Display	Using range (°C)	Using range (°F)
TC (thermo couple)	K (CA)	tc. p i	-200 to 1350 -328 to 2,462
	K (CA)	tc. p 2	-199.9 to 999.9 -328 to 1,832
	J (IC)	tc. - j	-199.9 to 800.0 -328 to 1,472
	E (CR)	tc. - e	-199.9 to 800.0 -328 to 1,472
	T (CC)	tc. - t	-199.9 to 400.0 -199.9 to 752.0
	R (PR)	tc. - r	0 to 1,750 32 to 3,182
	B (PR)*	tc. - b	0 to 1,800 212 to 3,272
	S (PR)*	tc. - s	0 to 1,750 32 to 3,182
	N (NN)*	tc. - n	-200 to 1,300 -328 to 2,372
	C (WS)*	tc. - c	0 to 2,300 32 to 4,172
RTD	L (IC)*	tc. - l	-199.9 to 900.0 -328 to 1,652
	U (CC)*	tc. - u	-199.9 to 400.0 -199.9 to 752.0
	Platinel II*	tc. - p	0 to 1,390 32 to 2,534
	Cu50Ω*	tc. u 0	-199.9 to 200.0 -199.9 to 392.0
	Cu100Ω*	tc. u 1	-199.9 to 200.0 -199.9 to 392.0
	JPT100Ω	tc. p t. i	-199.9 to 600.0 -328 to 1,112
Analog	DPT150Ω	tc. p t. s	-199.9 to 600.0 -328 to 1,112
	DPT100Ω	tc. p t. i	-199.9 to 850.0 -328 to 1,530
	Current	0.00 - 20.00 mA 4.00 - 20.00 mA	0.00 - 20.00 mA 4.00 - 20.00 mA
Voltage	-50.0 - 50.0 mV	0.00 - 50.00 mV	-199.9 to 9,999 (Display range is variable according to decimal point position.)
	-199.9 - 200.0 mV	0.00 - 200.00 mV	
	-1.000 - 1.000 V	0.00 - 1.000 V	
		-1.00 - 10.00 V	

* Above input types which have the * mark are displayed only in Input specification expansion. Refer to 'Mode Setting' to check how to enter the mode.

Display accuracy

Input type	Using temperature	Display accuracy
TC RTD	At room temperature (25 °C ± 5 °C)	PV ± 0.2% F.S. ± 1 digit • TC below -100 °C: (PV ± 0.4% F.S.) ± 1digit
	Out of room temperature range	PV ± 0.3% F.S. ± 1 digit

* In case of TC-T, TC-U, ± 2.0 °C will be added to the degree standard.

Dimensions

Unit: mm, For the detailed drawings, follow the website.

Panel cut-out

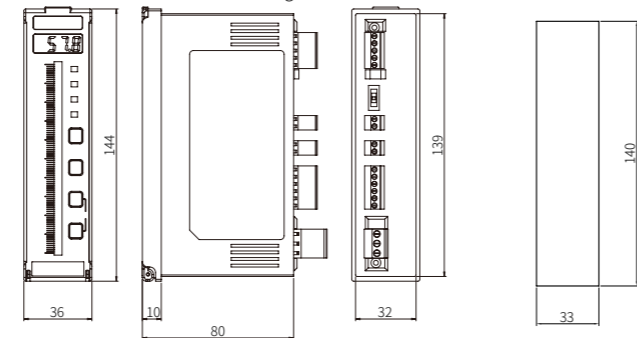

Bracket

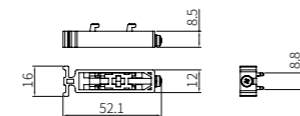

Unit Descriptions

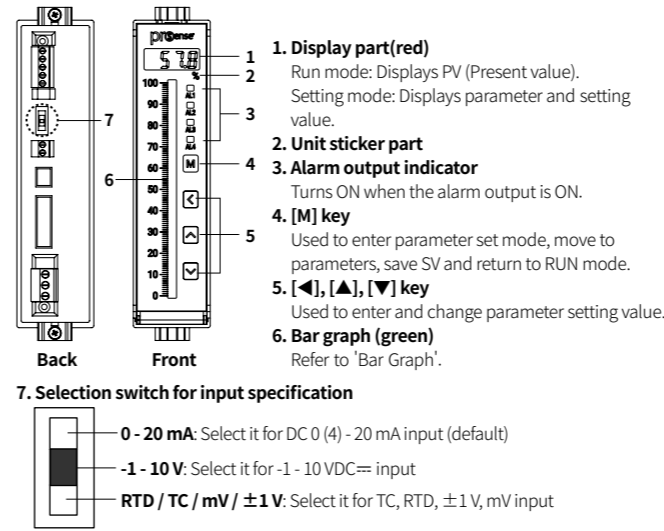

The setting of input type selection switch and the setting value of input type parameter must be the same to display the proper measurement value.

Connections

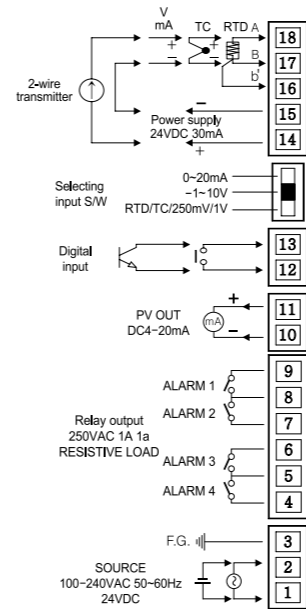

Errors

Display	Description	Troubleshooting
b u r n	Flashes when input sensor is disconnected or sensor is not connected.	Check input sensor status.
H H H H	Flashes when PV is higher than input range.	When input is within the rated input range, this display disappears.
L L L L	Flashes when PV is lower than input range.	When input is within the rated input range, this display disappears.
E r r	Flashes when there is an error of setting value	Check the setting condition and reset.

Mode Setting

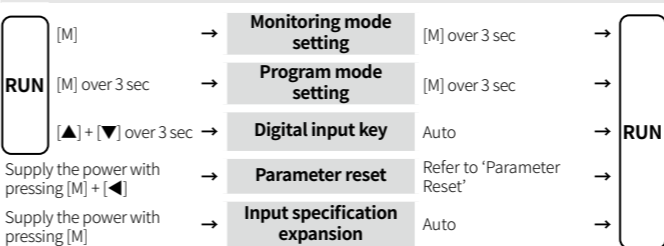

Parameter Reset

- Supply power while pressing [M]+ [◀] keys, CLR turns ON.
- Press [M] key for parameter reset mode.
- Change the setting value to YES by pressing the [▲], [▼] keys.
- Press the [M] key to reset all parameter values as default and to return to run mode.

Parameter Setting

- Some parameters are activated/deactivated depending on the setting of parameters. Refer to the descriptions of each item.
- [M] key: Move to next item after saving, [◀] key: Select parameter / Move digits, [▲], [▼] key: Select parameter / Change setting value
- Return to the RUN mode without saving when there is no key input for more than 30 seconds.

Monitoring Mode

Parameter	Display	Default	Setting range	Condition
1-1 AL1 temp.	AL 1	0999		2-15/17/19/21
1-2 AL2 temp.	AL 2	0999		2-15/17/19/21
1-3 AL3 temp.	AL 3	0001		2-15/17/19/21
1-4 AL4 temp.	AL 4	0001		2-15/17/19/21
1-5 High peak	HPE	---		2-15/17/19/21
1-6 Low peak	LPE	---		2-15/17/19/21

Program mode

Parameter	Display	Default	Setting range	Condition
2-1 Input spec.	i n p	RTD	Refer to 'Input Type and Using Range.'	-
2-2 Temp. unit	u n i t	°C	°C, °F	2-1 Input spec.: TC, RTD
2-3 Low limit input	L - r g	0000	Using range low limit ≤ L-RG ≤ using range high limit - 10% of F.S.	2-1 Input spec.: Analog
2-4 High limit input	H - r g	2000	L-RG + 10% of F.S. ≤ H-RG ≤ using range high limit	2-1 Input spec.: Analog
2-5 Decimal point	d p	00	0.0, 0.00, 0.000, 0	-
2-6 Low limit scale	L - 5 c	0000	-1,999 ≤ L-SC < H-SC ≤ 9,999	-
2-7 High limit scale	H - 5 c	1000	-999 to 999, L-SC ≤ L-RG ≤ H-SC	-
2-8 Input correction ⁽¹⁾	i n - b	0000	-999 to 999, L-SC ≤ L-RG ≤ H-SC	2-1 Input spec.: TC, RTD
2-9 Bar graph display low limit scale	L - b 5	0000	Input range low limit ≤ L-BS ≤ (H-BS-1) (L-BS+1) ≤ H-BS ≤ Input range high limit	2-1 Input spec.: Analog
2-10 Bar graph display high limit scale	H - b 5	1000	Input range low limit ≤ L-BS ≤ (H-BS-1) (L-BS+1) ≤ H-BS ≤ Input range high limit	2-1 Input spec.: Analog
2-11 Bar graph display method	b a r	F, b a r	F: Full bar, C: Center bar	-
2-12 4 mA trans. output scale	L o u t	0000	Input: TC, RTD: Within input range	-
2-13 20 mA trans. output scale	H o u t	1000	Input: Analog L-SC ≤ L-OUT ≤ 10% of F.S. ≤ H-OUT ≤ H-SC	-
2-14 Input and trans. output extension ⁽²⁾	E x t	5P	SV: Input range, Trans. output range OP: No extension, 4 - 20 mA 5P: ±5% extension, 3.2 - 20.8 mA 10P: ±10% extension, 2.4 - 21.6 mA	2-1 Input spec.: Analog
2-15 AL1 operation	AL - 1	AT 1 A	AT0: Off AT1: Absolute high limit alarm AT2: Absolute low limit alarm SBA: Sensor break alarm	-
2-16 AL1 option	AL - 1	AT 1 A	A: Standard alarm B: Alarm latch C: Standby D: Alarm latch and sequence standby sequence Enter to option setting: Press [◀] key in 2-15 AL-1 operation.	-
2-17 AL2 operation	AL - 2	AT 1 A		-
2-18 AL2 option	AL - 2	AT 1 A		-
2-19 AL3 operation	AL - 3	AT 2 A		-
2-20 AL3 option	AL - 3	AT 2 A		-
2-21 AL4 operation	AL - 4	AT 2 A		-
2-22 AL4 option	AL - 4	AT 2 A		-
2-23 Alarm output hysteresis	A - H y	001	001 to 999	2-15/17/19/21 AL1/2/3/4 operation: AT1, AT2
2-24 Input special function	i n 5 f	L i n	LIN: Linear, ROOT: Root, SQAR: Square, TUF: Two unit function	2-1 Input spec.: Analog
2-25 Input digital filter	ñ a u f	04	01 (OFF) to 16 • It does not affect the display cycle.	-
2-26 Digital input terminal ⁽³⁾	d i - t	H o l d	HOLD ⁽⁴⁾ : Hold, ZERO: Zero-point adjustment, AL.RE: Alarm reset	* 2-16/18/20/22 AL1/2/3/4 Alarm option: B, D
2-27 Digital input key ⁽³⁾	d i - p	H o l d		
2-28 Sensor break alarm output	b u r n	o f f	OFF: 4 mA, ON: 20 mA	-
2-29 Lock	L o c k	o f f	LOC1: Program mode lock (check only), Monitoring mode unlock LOC2: Checking and setting program mode lock, Monitoring mode setting lock (check only)	-

(1) When '2-24 input special function' parameter is set to 'TUF', the function corrects the atmospheric pressure input value.

(2) Extension is not allowed below 0 mA and 0 V. ± 1 V and 10 V inputs cannot be set to 10P.

(3) When changing functions, change after releasing the signal being input to the terminal.

(4) The hold function is maintained even when a temperature error occurs.

