

To minimize the risk of potential safety problems, you should follow all applicable local and national codes that regulate the installation and operation of your equipment. These codes vary from area to area and it is your responsibility to determine which codes should be followed, and to verify that the equipment, installation, and operation are in compliance with the latest revision of these codes.

Equipment damage or serious injury to personnel can result from the failure to follow all applicable codes and standards. We do not guarantee the products described in this publication are suitable for your particular application, nor do we assume any responsibility for your product design, installation, or operation.

If you have any questions concerning the installation or operation of this equipment, or if you need additional information, please call Technical Support at 770-844-4200.

This publication is based on information that was available at the time it was printed. At AutomationDirect.com® we constantly strive to improve our products and services, so we reserve the right to make changes to the products and/or publications at any time without notice and without any obligation. This publication may also discuss features that may not be available in certain revisions of the product.

Removable Terminal Block Specifications

Number of Positions	20 screw terminals
Wire Range	22-14 AWG (0.324 to 2.08 sq. mm) solid / stranded conductor 3/64 in. (1.2 mm) insulation maximum *USE COPPER CONDUCTORS, 60°C* or equivalent*.
Screw Driver Width	1/4 inch (6.5 mm) maximum
Screw Size	M3 size
Screw Torque	Field terminals – 7 - 9 in./lb (.0.882 - 1.02 Nm) Self-jacking screws – 2.7 - 3.6 in./lb (0.3 - 0.4 Nm). Do not overtighten screws when installing terminal block.



P3-04DA Analog Output

The P3-04DA Voltage/Current Analog Output Module provides 4 channels of ± 10 VDC or 4 - 20mA sink/source selectable outputs for use with the Productivity3000 Programmable Automation Controller.

Safety Information	1
Removable Terminal Block Specifications	1
General Specifications	2
Output Specifications	2
Schematic and Wiring Diagram	3
Module Installation Procedure	4
Terminal Block Removal	4
Hot Swap Information	4
Wiring Options	5
Module Configuration	5
Linear Scaling	6
Non-Linear Scaling	6
LCD Panel Display Menus	7

Terminal Block sold separately, Terminal Block Cover included (see wiring options on page 5).

Warranty: Thirty-day money-back guarantee. Two-year limited replacement. (See www.automationdirect.com/P3000 for details).

General Specifications

Operating Temperature	0° to 60°C (32° to 140°F),
Storage Temperature	-20° to 70°C (-4° to 158°F)
Humidity	5 to 95% (non-condensing)
Environmental Air	No corrosive gases permitted
Vibration	IEC60068-2-6 (Test Fc)
Shock	IEC60068-2-27 (Test Ea)
Field to Logic Side Isolation	1800VAC applied for 1 second
Insulation Resistance	>10MΩ @ 500 VDC
Heat Dissipation	2.6 W voltage outputs 3.4 W current outputs
Enclosure Type	Open Equipment
Agency Approvals	UL508 file E157382, Canada & USA UL1604 file E200031, Canada & USA CE (EN61131-2*) This equipment is suitable for use in Class 1, Division 2, Groups A, B, C and D or non-hazardous locations only.
Module Keying to Backplane	Electronic
Module Location	Any I/O slot in any local, expansion, or remote base in a Productivity3000 System.
Field Wiring	Removable terminal block (not included). Use ZIPLink Wiring System or optional terminal block. See "Wiring Options" on page 5.
EU Directive	See the "EU Directive" topic in the Productivity3000 Help File. Information can also be obtained at: www.automationdirect.com/P3000
Terminal Type (not included)	20-position removable terminal block
Weight	105g (3.73 oz)

*Meets EMC and Safety requirements. See the D.O.C. for details.

WARNING: Explosion hazard – Substitution of components may impair suitability for Class I, Division 2.

AVERTISSEMENT: Risque d'explosion : la substitution de composants peut compromettre la convenance pour la Classe I, Zone 2 ou pour la Classe I, Division 2.

Output Specifications

Output Channels	4
Module signal output range	±10V or 4-20mA sink or source selectable each channel
Signal Resolution	16-bit
Resolution Value of LSB (least significant bit)	± 10V = 305µV/ count 4-20mA = 0.244µA/ count 1 LSB = 1 count
Data Range	0 - 65535 counts uni-polar and -32768 to + 32767 counts bi-polar
Output Type	Voltage outputs sourcing/sinking at 10mA max, or Current outputs sink or source at 20mA max.
Output Value in Fault Mode	Voltage outputs 0V or 0mA current outputs
Load Impedence (Minimum External Power Supply)	>1000Ω voltage outputs (19.2 - 30 VDC) 0-755Ω Sinking, 0-600Ω Sourcing (19.2 VDC) 0-875Ω Sinking, 0-700Ω Sourcing (21.6 VDC) 0-1000Ω Sinking, 0-855Ω Sourcing (24.0 VDC) 0-1110Ω Sinking, 0-970Ω Sourcing (26.4 VDC) 0-1350Ω Sinking, 0-1150Ω Sourcing (30 VDC)
Maximum Capacitive Load	.01µF maximum voltage outputs
Maximum Inductive Load	1 mH maximum current outputs
Allowed Load Type	Grounded
Maximum Inaccuracy (% of range)	0.1% voltage, 0.1% current (including temperature drift)
Maximum Full Scale Calibration Error (not including offset error)	±.025% of range maximum voltage outputs ±.025% of range maximum current outputs
Maximum Offset Calibration Error	±.025% of range maximum
Accuracy vs. Temperature	±25 ppm/ °C max f.s. calibration change (± .0025% of range / °C)
Max Crosstalk	-80 dB, 6 LSB
Linearity Error (End to End)	±16 LSB maximum (±0.025% of full scale) Monotonic with no missing codes
Output Stability and Repeatability	±10 LSB after 10 minute warm-up (typical)
Output Ripple	.05% of Full Scale
Output Settling Time	0.3 ms max, 5 µs min (full scale change)
All Channel Update Rate	0.6ms
Maximum Continuous Overload	Voltage Outputs current limited to 35mA typical. Current Outputs open circuit protected
Type of Output Protection	15VDC Peak Output Voltage Current outputs current limited to <=20mA
Output Signal (power-up, -down)	0V voltage outputs, 0mA current outputs
External DC Power Required	94mA voltage operation 4 channels 126mA current operation 4 channels 24VDC -20% / + 25%

Wiring Diagram

Voltage Output

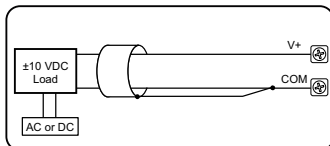
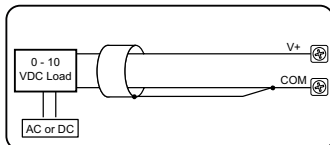

Current Source Output (Field device is sinking)

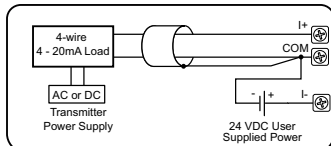
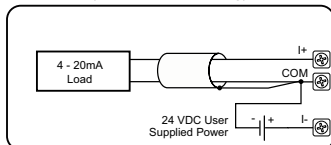

Current Sink Output (Field device is sourcing)

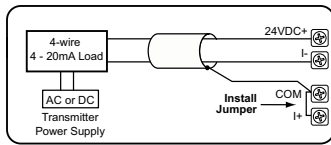
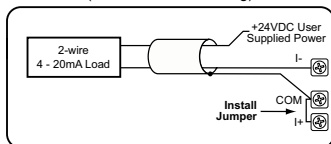

NOTE: Shield is connected to common at the source device.

Schematic

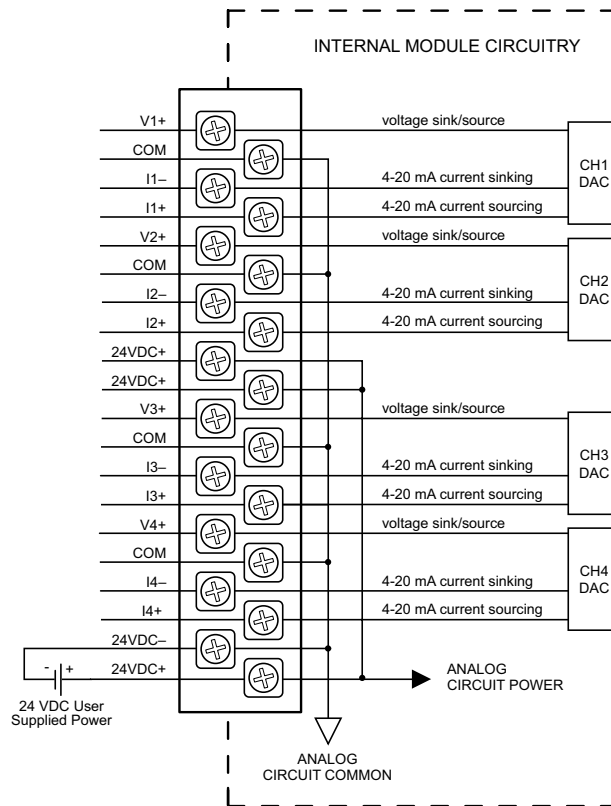

Module Installation Procedure

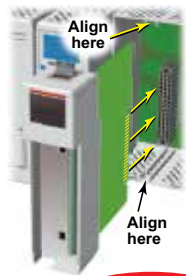

WARNING: Do not apply field power until the following steps are completed. See hot-swapping procedure for exceptions.
AVERTISSEMENT: Ne pas appliquer la puissance de champ avant l'exécution des étapes qui suivent. Consultez la procédure de remplacement à chaud pour les exceptions.

Step One: Align circuit card with slot and press firmly to seat module into connector.

Step Two: Pull top and bottom locking tabs toward module face. Click indicates lock is engaged.



Step Three: Attach field wiring using optional terminal block or ZIPLink wiring system and install cover.



To install or remove terminal block cover, press middle to flex cover.



WARNING: Explosion hazard – Do not connect or disconnect connectors or operate switches while circuit is live unless the area is known to be non-hazardous. Do not hot-swap modules unless the area is known to be non-hazardous.

AVERTISSEMENT: Risque d'explosion : ne pas connecter ou déconnecter les connecteurs ni actionner les commutateurs alors que le circuit est sous tension, à moins que la zone ne soit reconnue non dangereuse. Ne pas remplacer à chaud les modules à moins que la zone ne soit reconnue non dangereuse.

Terminal Block Removal

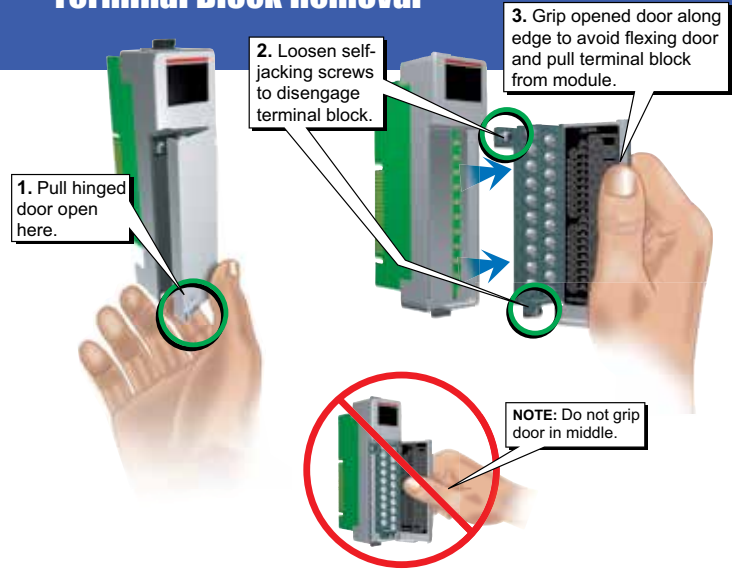

Important Hot-Swap Information

The Productivity3000 PAC supports hot-swap! Individual modules, expansion bases, and entire remote base groups can be taken offline, removed, and replaced while the rest of the PAC system continues controlling your process. Before attempting to use the hot-swap feature, be sure to read the hot-swap topic in the programming software's help file or our online documentation at AutomationDirect.com for details on how to plan your installation for use of this powerful feature.

Wiring Options

1 ZIPLink Connection System

Cable + ZIPLink Module = Complete System



ZIPLink pre-wired terminal block cables



0.5m (1.6FT) cable
1.0m (3.3FT) cable
2.0m (6.6FT) cable

ZL-P3-CBL20-L
ZL-P3-CBL20-1L
ZL-P3-CBL20-2L



ZIPLink Modules

Feed through

ZL-RTB20

2 Terminal Block with pigtail cable



0.5m (1.6FT) cable
1.0m (3.3FT) cable
2.0m (6.6FT) cable

ZL-P3-CBL20-P
ZL-P3-CBL20-1P
ZL-P3-CBL20-2P

3 Terminal Block only



P3-RTB
(Quantity 1)

Configuration Settings

Using the Hardware Configuration tool in the Productivity Suite programming software, drag and drop the P3-04DA module into the base configuration.

Select *Automatic Module Verification* or *No Verification and Enable Hot Swap*. If desired, assign a *User Tagname* to each output point (channel) selected and to each *Status Bit Item*. *Range* with sink/source option and *Stop Mode Value* may also be assigned.

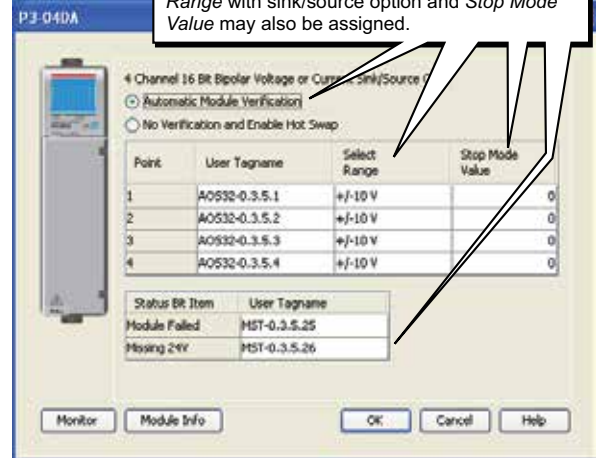

Linear Scaling

The Scale (Linear) function can be used to:

- Convert an application specific range to a range which is native to the analog output module.
- Make other linear conversions in ranges appropriate to the application.

Select the Input and Output tags appropriate for the application. Convert raw input signals to engineering units for use in the program, or convert engineering units to output signals for control purposes

Input	Output
min	min
max	max

Non-Linear Scaling

The Scale (Non-Linear) function can be used for Non-Linear applications.

Input value	Desired Output
0	0
1	0.5
2	1
3	1.55
4	2.25
5	3
6	4.55
6.5	6.75
7	7
0	0
0	0
0	0
0	0
0	0
0	0
0	0
0	0

Select the minimum and maximum values of the raw input signal. These values will relate to the minimum and maximum scaled values.

LCD Panel Display

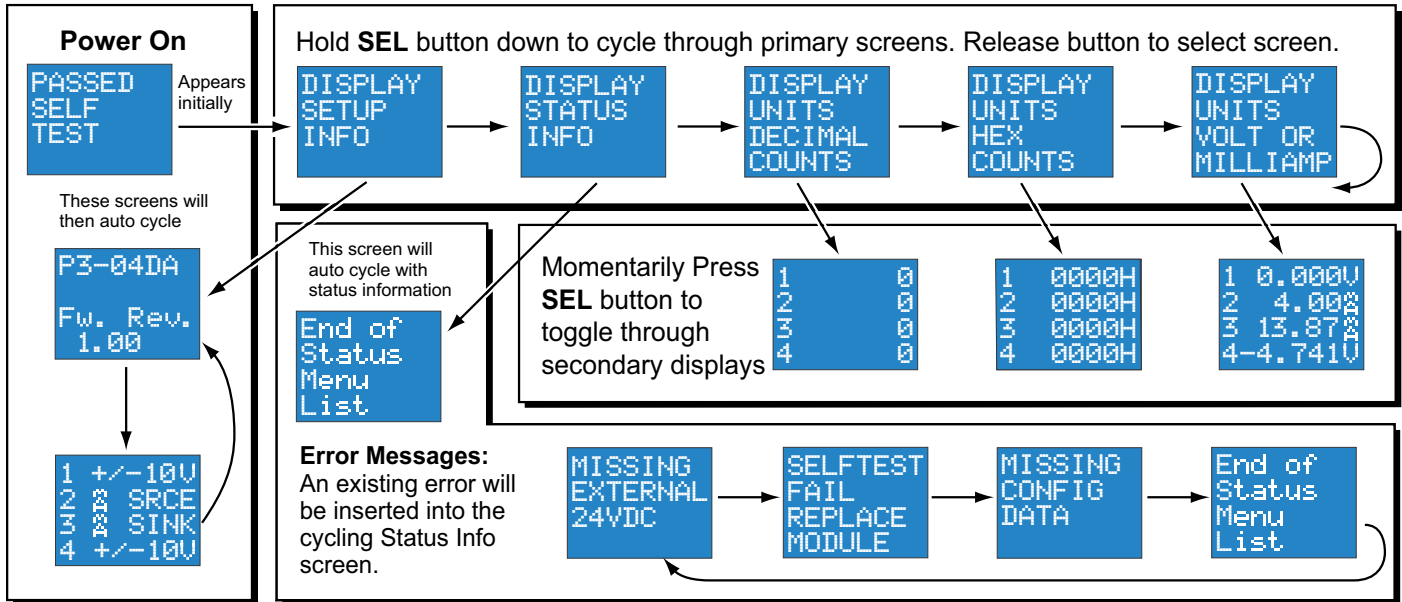

Document Name	Edition/Revision	Date
P3-04DA-M	1st Ed.Revision B	12/04/2017

Copyright 2017, AutomationDirect.com Incorporated/All Rights Reserved Worldwide