

WARNING: To minimize the risk of potential safety problems, you should follow all applicable local and national codes that regulate the installation and operation of your equipment. These codes vary from area to area and it is your responsibility to determine which codes should be followed, and to verify that the equipment, installation, and operation are in compliance with the latest revision of these codes.

Equipment damage or serious injury to personnel can result from the failure to follow all applicable codes and standards. We do not guarantee the products described in this publication are suitable for your particular application, nor do we assume any responsibility for your product design, installation, or operation.

If you have any questions concerning the installation or operation of this equipment, or if you need additional information, please call Technical Support at 770-844-4200.

This publication is based on information that was available at the time it was printed. At AutomationDirect.com® we constantly strive to improve our products and services, so we reserve the right to make changes to the products and/or publications at any time without notice and without any obligation. This publication may also discuss features that may not be available in certain revisions of the product.

Removable Terminal Block Specifications

Part Number	P2-RTB	P2-RTB-1
Number of positions	18 Screw Terminals	18 Spring Clamp Terminals
Wire Range	30–16 AWG (0.051–1.31 mm ²) Solid / Stranded Conductor	28–16 AWG (0.081–1.31 mm ²) Solid / Stranded Conductor
	3/64 in. (1.2 mm) Insulation Maximum	3/64 in (1.2 mm) Insulation Maximum
	1/4 in (6–7 mm) Strip Length	19/64 in (7–8 mm) Strip Length
Conductors	"USE COPPER CONDUCTORS, 75°C" or equivalent.	
Screw Driver Width	0.1 in (2.5 mm) Maximum*	
Screw Size	M2	N/A
Screw Torque	2.5 lb-in (0.28 N-m)	N/A

*Recommended Screwdriver TW-SD-MSL-1

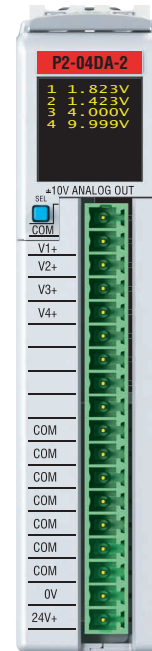

P2-04DA-2 Analog Output

The P2-04DA-2 Voltage Analog Output Module provides four channels of ± 10 VDC outputs for use with the Productivity2000 System.

Warning	1
Removable Terminal Block Specifications	1
General Specifications	2
Output Specifications	2
Wiring Diagram and Schematic	3
Module Installation Procedure	4
QR Code	4
Hot Swap Information	4
Wiring Options	5
Module Configuration	5
Linear Scaling	6
Non-Linear Scaling	6
OLED Panel Display Menus	7

Terminal Block sold separately, (see wiring options on page 5).

General Specifications

Operating Temperature	0° to 60°C (32° to 140°F)
Storage Temperature	-20° to 70°C (-4° to 158°F)
Humidity	5 to 95% (non-condensing)
Altitude	2,000 meters max
Pollution Degree	2
Environmental Air	No corrosive gases permitted
Vibration	IEC60068-2-6 (Test Fc)
Shock	IEC60068-2-27 (Test Ea)
Overvoltage Category	II
Field to Logic Side Isolation	1800VAC applied for 1 second
Insulation Resistance	> 10MΩ @ 500VDC
Heat Dissipation	2200mW
Enclosure Type	Open Equipment
Module Keying to Backplane	Electronic
Module Location	Any I/O slot in a Productivity2000 System
Field Wiring	Use ZIP Link Wiring System or removable terminal block (not included). See "Wiring Options" on page 5.
Connector Type (not included)	18-position removable terminal block
Weight	90g (3.2 oz)
Agency Approvals	UL 61010-1 and UL 61010-2-201 File E139594, Canada and USA CE (EN 61131-2 EMC, EN 61010-1 and EN 61010-2-201 Safety)*

*Meets EMC and Safety requirements. See the D.O.C. for details.

Output Specifications

Output Channels	4
Output Ranges	±10VDC
Signal Resolution	16-bit
Resolution Value of LSB (least significant bit)	±10V = 305µV/count 1 LSB = 1 count
Data Range	-32768 to +32767 counts
Output Type	Voltage: 10mA max
Output Value in Fault Mode	0V
Load Impedance	≥1000Ω
Maximum Capacitive Load (voltage output)	0.01 µF
Maximum Inductive Load (Current Output)	1mH
Allowed Load Type	Grounded
Maximum Inaccuracy	0.1% of range (including temperature drift)
Maximum Full Scale Calibration Error	±0.025% of range maximum
Maximum Offset Calibration Error	±0.025% of range maximum
Accuracy vs. Temperature	±25ppm/°C max full scale calibration change (±0.0025% of range/°C)
Maximum Crosstalk at DC, 50Hz and 60Hz	-96dB, 1 LSB
Linearity Error	±16 LSB maximum (±0.025% of full scale) Monotonic with no missing codes
Output Stability and Repeatability	±10 LSB after 10 minute warm-up (typical)
Output Ripple	0.05% of full scale
Output Setting Time	300µs max, 5µs min (full scale change)
All Channel Update Rate	1ms
Maximum Continuous Overload	Outputs current limited to 40mA typical Continuous overloads on multiple outputs can damage the module.
Type of Output Protection	0.1 µF Transient Suppressor
Output Signal (power-up,-down) or at Power Up and Power Down	0V
External Power Supply Required	24VDC (-20% / +25%), 75mA

Voltage Output Circuits

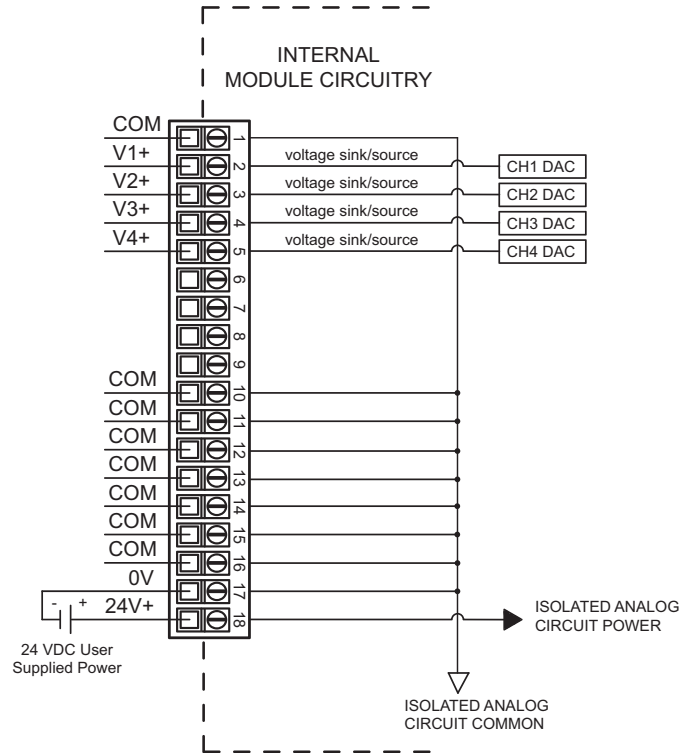
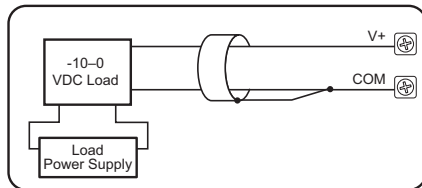
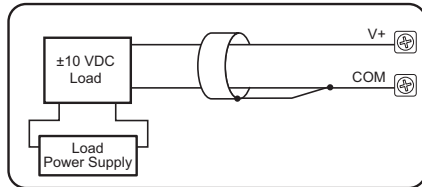
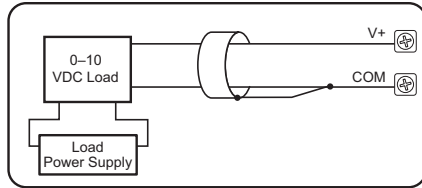

Module Installation

WARNING: Do not apply field power until the following steps are completed. See hot-swapping procedure for exceptions.

Step One: Align module catch with base slot and rotate module into connector.

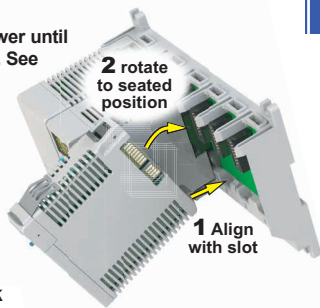

Step Two: Pull top locking tab toward module face. Click indicates lock is engaged.

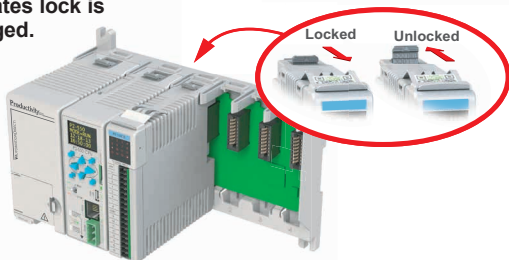

Step Three: Attach field wiring using the removable terminal block or ZIPLink wiring system.



QR Code



Use any QR Code reader application to display the module's product insert.

Caution: If possible, remove field power prior to proceeding. If not, then **EXTREME** care **MUST** be taken to prevent damage to the module, or even personal injury due to a short circuit from the live terminal block.

Important Hot-Swap Information

The Productivity2000 System supports hot-swap! Individual modules can be taken offline, removed, and replaced while the rest of the system continues controlling your process. Before attempting to use the hot-swap feature, be sure to read the hot-swap topic in the programming software's help file or our online documentation at AutomationDirect.com for details on how to plan your installation for use of this powerful feature.

Wiring Options

1 ZIPLink Feed Through Modules and Cables¹

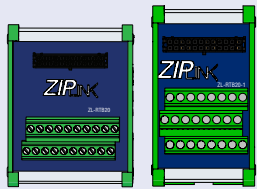

0.5 m (1.6 ft) cable
1.0 m (3.3 ft) cable
2.0 m (6.6 ft) cable



ZL-RTB20
ZL-RTB20-1

ZL-P2-CBL18
ZL-P2-CBL18-1
ZL-P2-CBL18-2

2 Terminal Block with pigtail cable



1.0 m (3.3 ft) cable
2.0 m (6.6 ft) cable

ZL-P2-CBL18-1P
ZL-P2-CBL18-2P

3 Screw Terminal Block only



P2-RTB
(Quantity 1)

4 Spring Clamp Terminal Block only

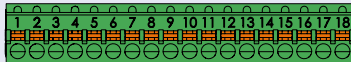

P2-RTB-1
(Quantity 1)

5 Accessories²

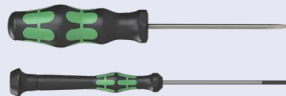
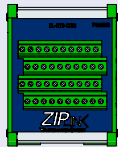

ZL-RTB-COM
TW-SD-SL-1
TW-SD-MSL-1

1. Cable + ZIPLink Module = Complete System

2. ZL-RTB-COM provides a common connection point for power or ground

Module Configuration

Using the Hardware Configuration tool in the Productivity Suite programming software, drag and drop the P2-04DA-2 module into the base configuration.

Select *Automatic Module Verification* or *No Verification and Enable Hot Swap* and *Stop Mode Values*. If desired, assign a *User Tagname* to each output point (channel) selected and to each *Status Bit Item*.

P2-04DA-2

4CH, 16-BIT, VOLTAGE, ANALOG OUTPUT

Automatic Module Verification
 No Verification and Enable Hot Swap

Add Default Tags Remove Default Tags

Point	User Tagname	Stop Mode Value
1	AOS32-0.1.1.1	0
2	AOS32-0.1.1.2	0
3	AOS32-0.1.1.3	0
4	AOS32-0.1.1.4	0

Status Bit	User Tagname
Module Failed	MST-0.1.1.25
Missing 24V	MST-0.1.1.26

Module Info Monitor **OK** Cancel Help

Linear Scaling

The Scale (Linear) function can be used to:

- Convert an application specific range to a range which is native to the analog output module.
- Make other linear conversions in ranges appropriate to the application.

Select the Input and Output tags appropriate for the application. Convert raw input signals to engineering units for use in the program, or convert engineering units to output signals for control purposes

Input	Output
min	min
max	max

Non-Linear Scaling

The Scale (Non-Linear) function can be used for Non-Linear applications.

Input value	Desired Output
0	0
1	0.5
2	1
3	1.55
4	2.25
5	3
6	4.55
6.5	6.75
7	7
0	0
0	0
0	0
0	0
0	0
0	0

Select the minimum and maximum values of the raw input signal. These values will relate to the minimum and maximum scaled values.

OLED Panel Display

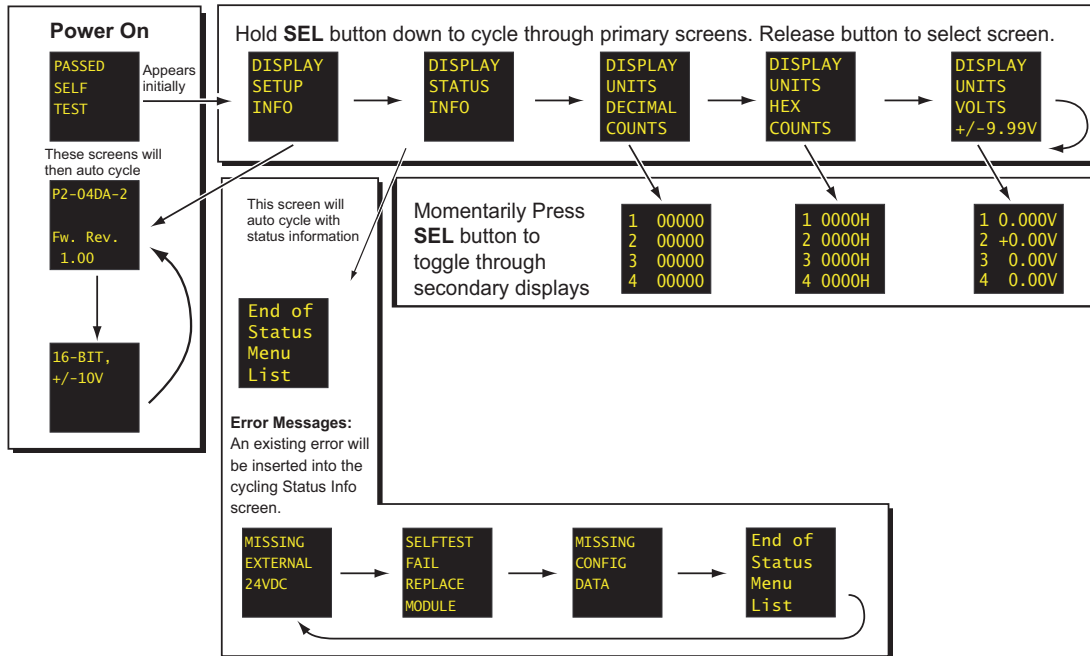

Document Name	Edition/Revision	Date
P2-04DA-2-DS	1st Edition, Rev A	5/14/2024

Copyright 2019, AutomationDirect.com Incorporated/All Rights Reserved Worldwide