

**WARNING:** To minimize the risk of potential safety problems, you should follow all applicable local and national codes that regulate the installation and operation of your equipment. These codes vary from area to area and it is your responsibility to determine which codes should be followed, and to verify that the equipment, installation, and operation are in compliance with the latest revision of these codes. *Equipment damage or serious injury to personnel can result from the failure to follow all applicable codes and standards. We do not guarantee the products described in this publication are suitable for your particular application, nor do we assume any responsibility for your product design, installation, or operation.*

If you have any questions concerning the installation or operation of this equipment, or if you need additional information, please call Technical Support at 770-844-4200.

This publication is based on information that was available at the time it was printed. At AutomationDirect.com® we constantly strive to improve our products and services, so we reserve the right to make changes to the products and/or publications at any time without notice and without any obligation. This publication may also discuss features that may not be available in certain revisions of the product.

## Connector Specifications

Connector Type	IDC style header with latch, Omron XG4A-4034
Number of Pins	40 point
Pitch	0.1 in (2.54 mm)

Document Name	Edition/Revision	Date
P2-HSI-DS	1st Ed. Rev. B	4/26/2018



## P2-HSI High-Speed Isolated Sinking/Sourcing Input

The P2-HSI High-Speed Input Module provides differential (line receiver, 5V max) and single ended (5–24 V) inputs that accept up to 1MHz of pulse/direction and quadrature signals on each of the two independent input channels. Additionally, four 5–24 VDC general purpose high-speed inputs and four general purpose 5–24 VDC, 0.5A outputs are included for use with any Productivity2000 System.

Warning	1
Connector Specifications	1
General Specifications	2
Status LEDs	2
Status Output Specifications	2
Power Specifications	2
Single Ended (5–24 V) Input Specifications	3
Differential (5V) Input Specifications	3
Hot Swap Information	3
Module Installation	4
Wiring Options	4
QR Code	4
Frequency Measurement Details	5
5V Encoder Inputs Wiring Diagram	6
24V Encoder Inputs Wiring Diagram	6
Status Inputs Wiring Diagram	7
Status Outputs Wiring Diagram	7
Sinking I/O Wiring Diagram	8
Sourcing I/O Wiring Diagram	8

## General Specifications

Module Type	Intelligent
Modules per Base	15 maximum*
I/O Points Used	None, mapped directly to tags in CPU
Operating Temperature	0° to 60°C (32° to 140°F)
Storage Temperature	-20° to 70°C (-4° to 158°F)
Humidity	5 to 95% (non-condensing)
Environmental Air	No corrosive gases permitted
Vibration	IEC 60068-2-6 (Test Fc)
Shock	IEC 60068-2-27 (Test Ea)
Field to Logic Side Isolation	1800VAC applied for 1 second
Insulation Resistance	>10MΩ @ 500VDC
Heat Dissipation	5.76 W
Enclosure Type	Open Equipment
Agency Approvals	UL508 File E139594, Canada & USA CE (EN61131-2**)
Module Location	Any I/O slot in a Productivity2000 System
Field Wiring	Use ZIPLink Wiring System. See "Wiring Options" on page 4.
EU Directive	See the "EU Directive" topic in the Productivity Suite Help File. Information can also be obtained at: <a href="http://www.productivity2000.com">www.productivity2000.com</a>
Weight	90g (3.2 oz)

\***Note:** For complete system limits, please refer to the "Hardware and Communication Limits" table in the Productivity Suite Help file, "Hardware Configuration" topic (P050).

\*\*Meets EMC and Safety requirements. See the D.O.C. for details.

## Status LEDs

Fault Status LEDs	(F) 1, 2, 3 & 4 (one per status output)
Input LEDs	(IN) 1A, 1B, 1Z, 2A, 2B, 2Z, IN3 & IN4 (one per status input)
Output Status LEDs	(O) OUT1, OUT 2, OUT3 & OUT4

**Note:** Top row fault LED's blinking indicates loss of external power.

## Status Output Specifications

Status Outputs	4 sink/source	
Output Signal Type, per Channel Select	Current Sinking	Current Sourcing
Operating Voltage <sup>1</sup>	5–24 VDC	5–24 VDC <sup>1</sup>
Output Volts Maximum	36VDC	26.4 VDC <sup>1</sup>
Output Current Maximum	500mA	
Overcurrent Protection	Short circuit detect and current limit with automatic retry for each output	
Output Self Limiting Current	1.2 to 2.4 A	
Max Inrush Current	Self limited	
Output Voltage Drop	0.7 VDC @ 0.5 A	
Thermal Protection	Independent over temperature protection each output	
Output Voltage Clamp During Inductive Switching	+45VDC	-20VDC
Maximum OFF to ON Response	25μs <sup>2</sup>	
Maximum ON to OFF Response	25μs <sup>2</sup>	

### NOTES:

1. Operating voltage of current sourcing outputs must be no greater than external power.
2. Measured at 5VDC operating voltage, 0.5 A load current.

## Power Specifications

External Power	24VDC -15% / +10%, Class 2
Maximum Voltage	26.4 VDC
Minimum Voltage	20.4 VDC
Current Consumption Excluding Outputs	50mA
Maximum Current Consumption Total of the 4 Status Outputs	2A

## Single Ended (5-24V) Input Specifications

Status Input	Single ended inputs (8 pts: 1A, 1B, 1Z, 2A, 2B, 2Z, 3IN, 4IN)
Isolation	Each input is isolated from other circuits
Input Volts Range	5–24 VDC
Input Volts Maximum	±34VDC, limited by protection
Input Impedance	1kΩ minimum, 5kΩ maximum
Inputs Rated Current	5–24 VDC, 16mA 5.2 mA typical @ 5VDC 22mA maximum @ 34VDC
Input Minimum ON Voltage	4.5 VDC
Input Maximum OFF Voltage	2.0 VDC
Input Minimum ON Current	5.0 mA
Input Maximum OFF Current	1.4 mA
OFF to ON Response Time	1A, 1B, 2A, 2B: 0.48 μs 1Z, 2Z, 3IN, 4IN: 6μs
ON to OFF Response Time	1A, 1B, 2A, 2B: 0.48 μs 1Z, 2Z, 3IN, 4IN: 6μs
Max. Input Frequency	1A, 1B, 2A, 2B: 1MHz 1Z, 2Z, 3IN, 4IN: 200kHz

\*Inputs are not limited to this speed but single ended signals are not usually reliable above 200kHz due to cabling capacitance.

## Differential (5V) Input Specifications

Pulse Inputs	Differential inputs (6 pts: 1A, 1B, 1Z, 2A, 2B, 2Z)
Isolation	Each input is isolated from other circuits
Input Signal Type, per Channel Select	Differential
Input Volts	5VDC
Input Volts Maximum	+/-5.6 VDC, limited by protection
Input Impedance	200Ω minimum, 500Ω maximum
Input Rated Current	5VDC, 15mA (8mA typical, 15mA maximum)
Input Minimum ON Voltage	3.0 VDC
Input Maximum OFF Voltage	1.0 VDC
Input Minimum ON Current	5.0 mA
Input Maximum OFF Current	2.0 mA
OFF to ON Response Time	1A, 1B, 2A, 2B: 0.48 μs 1Z, 2Z, 3IN, 4IN: 6μs
ON to OFF Response Time	1A, 1B, 2A, 2B: 0.48 μs 1Z, 2Z, 3IN, 4IN: 6μs
Max. Input Frequency	1A, 1B, 2A, 2B: 1MHz 1Z, 2Z, 3IN, 4IN: 200kHz

**NOTE:** The voltage difference between the input pairs must be between 3-5.6 volts. \*The Z pulse input (1Z & 2Z) is capable of capturing a 1MHz wide pulse for the purpose of resetting an encoder count but a 3 microsecond pause (300kHz) is required between pulses.

**Caution:** *If possible, remove field power prior to proceeding. If not, then **EXTREME** care **MUST** be taken to prevent damage to the module, or even personal injury due to a short circuit from the live terminal block.*

### Important Hot-Swap Information

#### The Productivity2000 System supports hot-swap!

Individual modules can be taken offline, removed, and replaced while the rest of the system continues controlling your process. Before attempting to use the hot-swap feature, be sure to read the hot-swap topic in the programming software's help file or our online documentation at [AutomationDirect.com](http://AutomationDirect.com) for details on how to plan your installation for use of this powerful feature.

# Module Installation

**WARNING:** Do not apply field power until the following steps are completed. See hot-swapping procedure for exceptions.

**Step One:** Align module catch with base slot and rotate module into connector.

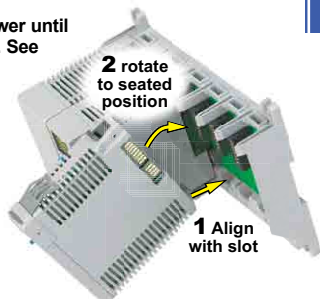

**Step Two:** Pull top locking tab toward module face. Click indicates lock is engaged.

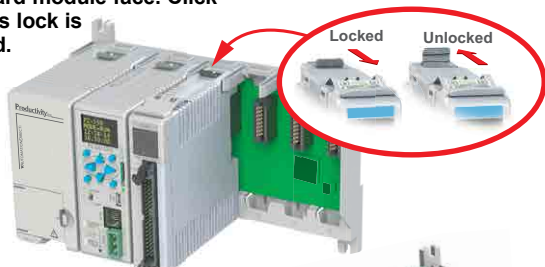

**Step Three:** Attach field wiring using the ZIPLink wiring system.



## Wiring Options

### ZIPLink Connection System

Cable + ZIPLink Module = Complete System

ZIPLink pre-wired cables



0.5 m (1.6 ft) cable  
1.0 m (3.3 ft) cable  
2.0 m (6.6 ft) cable

### ZIPLink Modules



Feed through

**Note:** P2-HSO is UL/CUL listed when used with ZL-RTB40.

**ZIPLINK**  
AUTOMATIONDIRECT

ZL-CBL40-S  
ZL-CBL40-1S  
ZL-CBL40-2S

ZL-RTB40

## QR Code



Use any QR Code reader application to display the module's product insert.

# Frequency Measurements

## Inaccuracy of Frequency Measurements Due to Time Base Errors

25 MHz Crystal for Time Base	
Inaccuracy at 25°C, Maximum	±30 PPM
Inaccuracy 0-60°C, Referenced to 25°C	±30 PPM
Inaccuracy Due to Aging, Maximum	±5 PPM/Year
Max. Time Base Inaccuracy 0-60°C and 10 Years Operation	0.01%

## Resolution of Frequency Measurements for “Fast Mode”

Input Frequency	Sampling Period	Resolution
1Hz to 1MHz	1000ms	±1 Hz
10Hz to 1MHz	100ms	±10 Hz
100Hz to 1MHz	10ms	±100 Hz
1MHz	1ms	±1000 Hz

**Module Range:** Target position range ± 2.147 billion (32-bit signed integer)

**NOTE:** Refer to the I/O Module Configuration Help File Topic (P212) in the Productivity Suite Software for more information on Mode selections.

## Inaccuracy of Frequency Measurements<sup>1,2</sup> for “Slow Mode”

Input Frequency	Step/Dir	Quadrature 1X	Quadrature 4X
1Hz	±0.002 Hz	±0.002 Hz	±0.002 Hz
10Hz	±0.009 Hz	±0.009 Hz	±0.009 Hz
100Hz	±0.015 Hz	±0.015 Hz	±0.015 Hz
1kHz	±1 Hz	±1 Hz	±1 Hz
10kHz	±100 Hz	±100 Hz	±100 Hz
100kHz	±1000 Hz	±1000 Hz	±1000 Hz
1MHz	±40000 Hz	±40000 Hz	±40000 Hz

## Inaccuracy of Frequency Measurements<sup>1,2</sup> for “Fast Mode”

Input Frequency	Sampling Period	Step/Dir	Quadrature 1X	Quadrature 4X
1Hz	±1 Second	±1 Hz	±1 Hz	±1 Hz
10Hz	±1 Second	±1 Hz	±1 Hz	±1 Hz
100Hz	±1 Second	±1 Hz	±1 Hz	±1 Hz
1kHz	±1 Second	±1 Hz	±1 Hz	±1 Hz
10kHz	±1 Second	±1 Hz	±1 Hz	±1 Hz
100kHz	±1 Second	±1 Hz	±1 Hz	±1 Hz
1MHz	±1 Second	±1 Hz	±1 Hz	±1 Hz

## Inaccuracy of Frequency Measurements<sup>1,2,3,4</sup> for “Auto Mode”

Input Frequency	Step/Dir	Quadrature 1X	Quadrature 4X
1Hz	±1 Hz	±1 Hz	±1 Hz
10Hz	±1 Hz	±1 Hz	±1 Hz
100Hz	±1 Hz	±1 Hz	±1 Hz
1kHz	±1 Hz	±1 Hz	±1 Hz
10kHz	±100 Hz	±100 Hz	±100 Hz
100kHz	±1000 Hz	±1000 Hz	±1000 Hz
1MHz	±10000 Hz	±10000 Hz	±10000 Hz

1. For stable input signal at given input frequency.
2. For total measurement error add the time base error to the tabulated error.
3. Maximum sample period: 1 second.
4. Minimum sample period: 0.001 seconds.

# 5V Encoder Inputs Wiring Diagram

# 24V Encoder Inputs Wiring Diagram

To prevent damage to P2-HSI 5V inputs, do not exceed 6.8V or 30 mA on inputs 1A, 1A̅, 1B, 1B̅, 1Z, 1Z̅, 2A, 2A̅, 2B, 2B̅, 2Z, & 2Z̅.

## Encoder with 5V Line Drivers

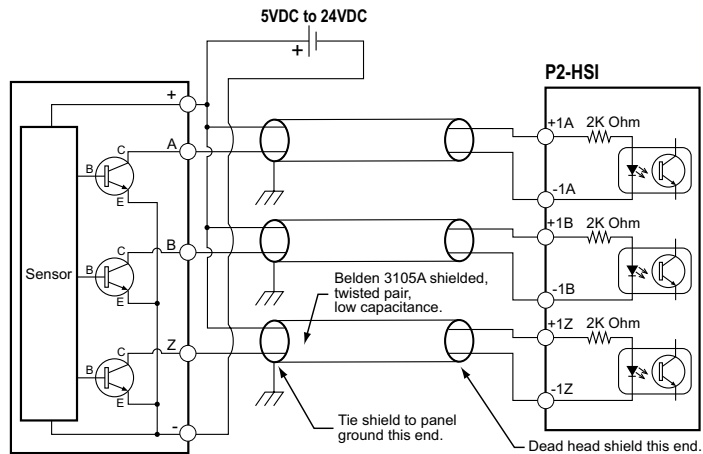
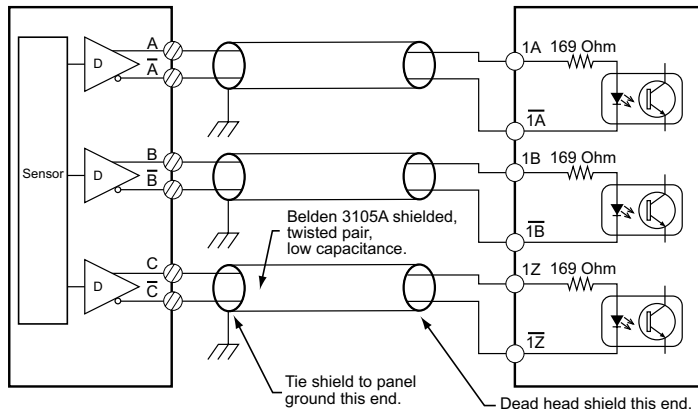

# Status Inputs Wiring Diagram

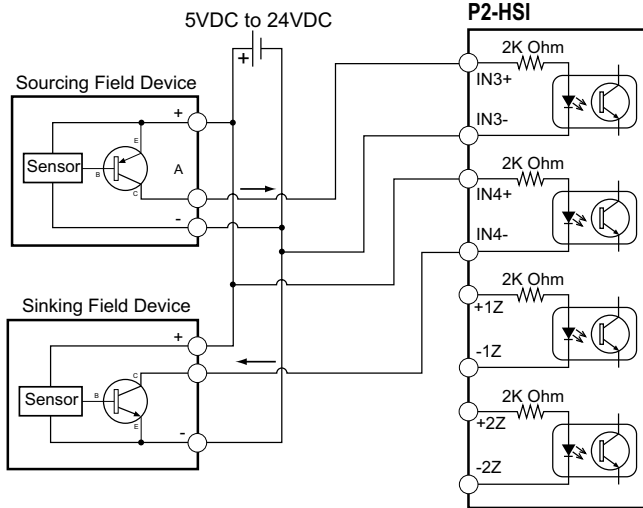

# Status Outputs Wiring Diagram

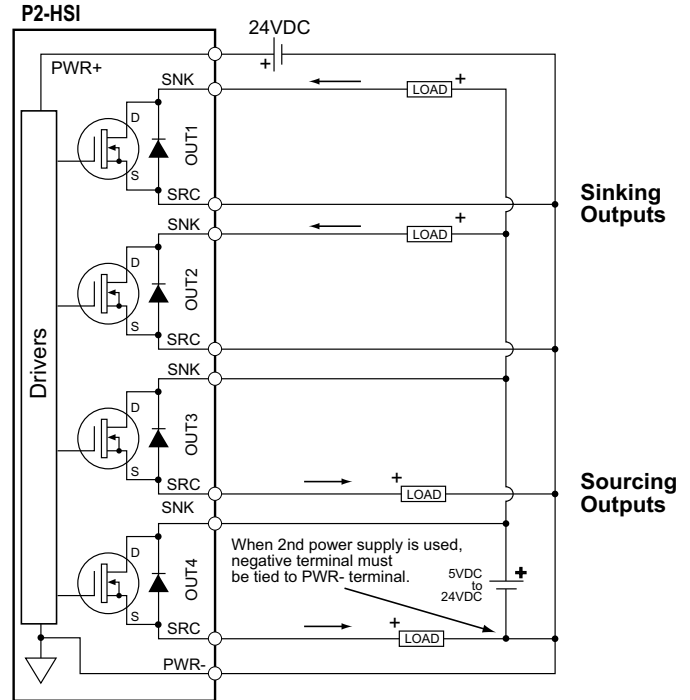

# Sinking I/O Wiring Diagram

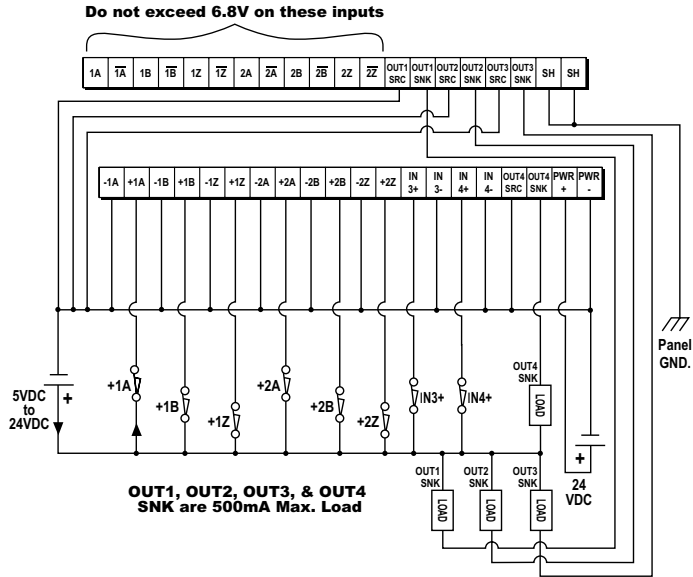

# Sourcing I/O Wiring Diagram

