

## Input Specifications

Inputs per Module	8 (sink/source)
Operating Voltage Range	12–24 VDC
Input Voltage Range	10.2–26.4 VDC, Max 30 VDC
Input Current (typical)	8.4 mA @ 24 VDC
Maximum Input Current	10 mA @ 26.4 VDC
Input Impedance	3 kΩ
ON Voltage Level	> 9 VDC
OFF Voltage Level	< 4.5 VDC
Minimum ON Current	1.4 mA
Maximum OFF Current	1 mA
OFF to ON, ON to OFF Response	2 ms Maximum, 1 ms Typical
Status Indicators	Logic Side (8 points)
Commons	1 (8 points/common)

## Output Specifications

Outputs per Module	7 sinking
Output Type	N-channel MOSFET, open drain
Rated Voltage	3.3–24 VDC
Operating Voltage Range	2.9–26.4 VDC
Maximum Output Current	1A per point / 7A per common @ 60°C 2A per point / 8A per common @ 55°C <sup>1</sup>
Minimum Load Current	1 mA
Maximum Leakage Current	0.3 mA @ 26.4 VDC
On Voltage Drop	0.15 VDC @ 1A 0.30 VDC @ 2A
Maximum Inrush Current	4A for 50 ms, 6A for 10ms
OFF to ON, ON to OFF Response	≤0.5 ms
Status Indicators	Logic Side (7 points)
Commons	1 (7 points/common)
Protection Circuit	Not built into module - Install protection elements such as external fuse - 8A
External Power Supply Required	12–24 VDC (-15% / +20%) @ 22 mA

1. See P2000 User Manual for Temperature Derating Chart for Inputs and Outputs.

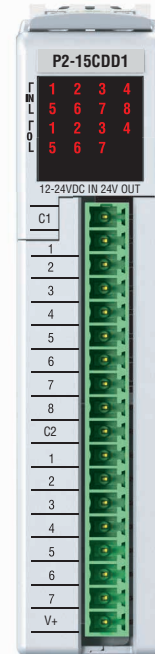

## P2-15CDD1 Input / Output

The P2-15CDD1 Input/Output Module provides eight 12–24 VDC inputs plus seven outputs that sink up to 2A per output for loads connected to 3.3–24 VDC supplies for use with the Productivity2000 System.

Input Specifications .....	1
Output Specifications .....	1
Module Installation .....	2
QR Code .....	2
Hot Swap Information .....	2
Wiring Options .....	3
Wiring Diagram and Schematic .....	3
Warning .....	4
Removable Terminal Block Specifications .....	4
General Specifications .....	4
Output Derating Chart .....	4

**Terminal Block sold separately, (see wiring options on page 3).**

Document Name	Edition/Revision	Date
P2-15CDD1-DS	1st Edition	2/9/2026

# Module Installation

**WARNING:** Do not apply field power until the following steps are completed. See hot-swapping procedure for exceptions.

**Step One:** Align module catch with base slot and rotate module into connector.

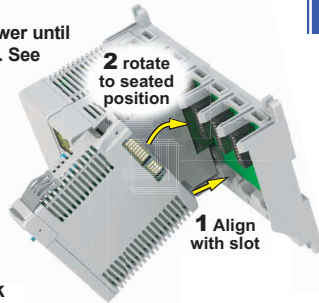

**Step Two:** Pull top locking tab toward module face. Click indicates lock is engaged.

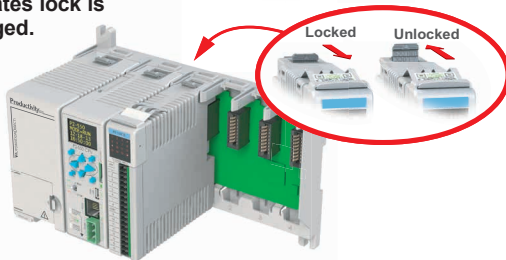

**Step Three:** Attach field wiring using the removable terminal block or ZIPLink wiring system.

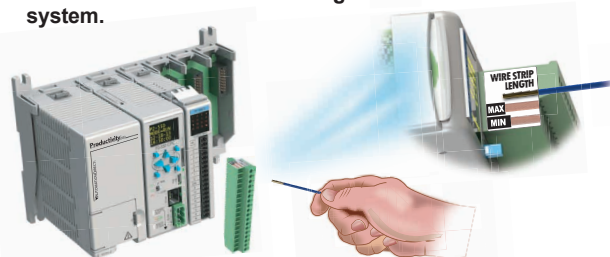

# QR Code



Use any QR Code reader application to display the module's product insert.

**Caution:** If possible, remove field power prior to proceeding. If not, then **EXTREME** care **MUST** be taken to prevent damage to the module, or even personal injury due to a short circuit from the live terminal block.

## Important Hot-Swap Information

**The Productivity2000 supports hot-swap!** Individual modules can be taken offline, removed, and replaced while the rest of the system continues controlling your process. Before attempting to use the hot-swap feature, be sure to read the hot-swap topic in the programming software's help file or our online documentation at [AutomationDirect.com](http://AutomationDirect.com) for details on how to plan your installation for use of this powerful feature.

# Wiring Options

## 1 ZIPLink Feed Through Modules and Cables<sup>1</sup>

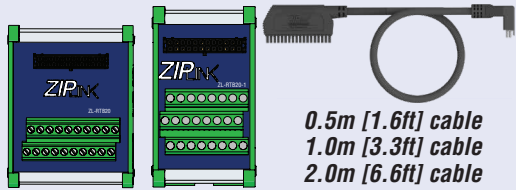

0.5m [1.6ft] cable  
1.0m [3.3ft] cable  
2.0m [6.6ft] cable

**ZIPLINK**  
AUTOMATIONDIRECT

ZL-RTB20  
ZL-RTB20-1

ZL-P2-CBL18  
ZL-P2-CBL18-1  
ZL-P2-CBL18-2

## 2 Terminal Block with pigtail cable



1.0m [3.3ft] cable  
2.0m [6.6ft] cable

ZL-P2-CBL18-1P  
ZL-P2-CBL18-2P

## 3 Screw Terminal Block only

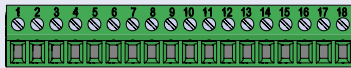

P2-RTB  
(Quantity 1)

## 4 Spring Clamp Terminal Block only

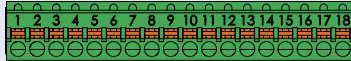

P2-RTB-1  
(Quantity 1)

## 5 Accessories<sup>2</sup>

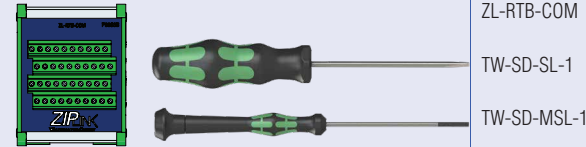

ZL-RTB-COM  
TW-SD-SL-1  
TW-SD-MSL-1

1. Cable + ZIPLink Module = Complete System
2. ZL-RTB-COM provides a common connection point for power or ground

# Wiring Diagram and Schematic

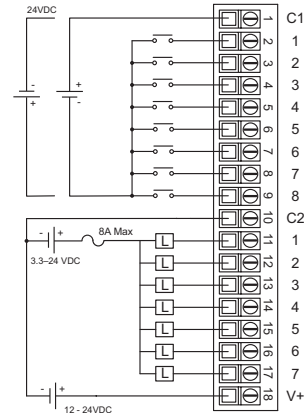
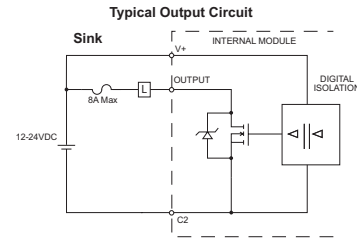
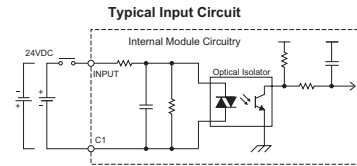

**WARNING:** To minimize the risk of potential safety problems, you should follow all applicable local and national codes that regulate the installation and operation of your equipment. These codes vary from area to area and it is your responsibility to determine which codes should be followed, and to verify that the equipment, installation, and operation are in compliance with the latest revision of these codes.

***Equipment damage or serious injury to personnel can result from the failure to follow all applicable codes and standards. We do not guarantee the products described in this publication are suitable for your particular application, nor do we assume any responsibility for your product design, installation, or operation.***

If you have any questions concerning the installation or operation of this equipment, or if you need additional information, please call Technical Support at 770-844-4200.

This publication is based on information that was available at the time it was printed. At AutomationDirect.com® we constantly strive to improve our products and services, so we reserve the right to make changes to the products and/or publications at any time without notice and without any obligation. This publication may also discuss features that may not be available in certain revisions of the product.

## Removable Terminal Block Specifications

Part Number	P2-RTB	P2-RTB-1
Number of Positions	18 Screw Terminals	18 Spring Clamp Terminals
Wire Range	30–16 AWG [0.051–1.31 mm <sup>2</sup> ] Solid / Stranded Conductor 3/64 in [1.2 mm] Insulation Maximum 1/4 in [6–7 mm] Strip Length	28–16 AWG [0.081–1.31 mm <sup>2</sup> ] Solid / Stranded Conductor 3/64 in [1.2 mm] Insulation Maximum 19/64 in [7–8 mm] Strip Length
Conductors	*USE COPPER CONDUCTORS, 75°C or Equivalent.	
Screw Driver Width	0.1 inch [2.5 mm] Maximum*	
Screw Size	M2	N/A
Screw Torque	2.5 lb-in [0.28 N-m]	N/A

\*Recommend Screw Driver TW-SD-MSL-1

## General Specifications

Operating Temperature	0 to 60 °C [32 to 140 °F]
Storage Temperature	-20° to +70 °C [-4° to +158 °F]
Humidity	5 to 95% (non-condensing)
Altitude	2,000 meters max
Pollution Degree	2
Environmental Air	No corrosive gases permitted
Vibration	IEC60068-2-6 (Test Fc)
Shock	IEC60068-2-27 (Test Ea)
Overvoltage Category	II
Field to Logic Side Isolation	1250 VAC applied for 5 seconds 300 VAC applied for 1 minute
Insulation Resistance	>10 MΩ @ 500 VDC
Heat Dissipation	3400 mW
Enclosure Type	Open Equipment
Module Keying to Backplane	Electronic
Module Location	Any I/O slot in a Productivity2000 System.
Field Wiring	Use <b>ZIPLink</b> Wiring System or removable terminal block (sold separately). See "Wiring Options" on page 3.
Connector Type (sold separately)	18 Position Removable Terminal Block
Weight	97g [3.4 oz]
Agency Approvals	UL 61010-1 and UL 61010-2-201 File E139594, Canada and USA CE (EN 61131-2 EMC, EN 61010-1 and EN 61010-2-201 Safety)*

\*See CE Declaration of Conformity for details.