

OP-1500/OP-1510

Operator Panel

Manual Number OP-1510-M



WARNING

Thank you for purchasing automation equipment from **PLCDirect™**. We want your new **DirectLOGIC™** automation equipment to operate safely. Anyone who installs or uses this equipment should read this publication (and any other relevant publications) before installing or operating the equipment.

To minimize the risk of potential safety problems, you should follow all applicable local and national codes that regulate the installation and operation of your equipment. These codes vary from area to area and usually change with time. It is your responsibility to determine which codes should be followed, and to verify that the equipment, installation, and operation is in compliance with the latest revision of these codes.

At a minimum, you should follow all applicable sections of the National Fire Code, National Electrical Code, and the codes of the National Electrical Manufacturer's Association (NEMA). There may be local regulatory or government offices that can also help determine which codes and standards are necessary for safe installation and operation.

Equipment damage or serious injury to personnel can result from the failure to follow all applicable codes and standards. We do not guarantee the products described in this publication are suitable for your particular application, nor do we assume any responsibility for your product design, installation, or operation.

If you have any questions concerning the installation or operation of this equipment, or if you need additional information, please call us at 1-800-633-0405.

This publication is based on information that was available at the time it was printed. At **PLCDirect™** we constantly strive to improve our products and services, so we reserve the right to make changes to the products and/or publications at any time without notice and without any obligation. This publication may also discuss features that may not be available in certain revisions of the product.



Trademarks

This publication may contain references to products produced and/or offered by other companies. The product and company names may be trademarked and are the sole property of their respective owners. **PLCDirect™** disclaims any proprietary interest in the marks and names of others.

Stage is a trademark of Koyo Electronics Industries Co., LTD. Texas Instruments is a registered trademark of Texas Instruments, Inc. TI, TIWAY, Series 305, Series 405, TI305, and TI405 are trademarks of Texas Instruments, Inc. Siemens and SIMATIC are registered trademarks of Siemens, AG. GE is a registered trademark of General Electric Corporation. Series One is a registered trademark of GE Fanuc Automation North America, Inc. MODBUS is a registered trademark of Gould, Inc. IBM is a registered trademark of International Business Machines. MS-DOS and Microsoft are registered trademarks of Microsoft Corporation. Windows is a trademark of Microsoft Corporation. OPTOMUX and PAMUX are trademarks of OPTO 22.

**Copyright 1997, PLCDirect™ Incorporated
All Rights Reserved**

No part of this manual shall be copied, reproduced, or transmitted in any way without the prior, written consent of **PLCDirect™** Incorporated. **PLCDirect™** retains the exclusive rights to all information included in this document.

Manual Revisions

If you contact us in reference to this manual, be sure and include the revision number.

Title: OP-1500/OP-1510 Operator Panel User Manual

Manual Number: OP-1510-M

Issue	Date	Effective Pages	Description of Changes
Original	1/96	Cover/Copyright Contents Manual Revisions 1 — 70	Original Issue
2nd Edition	2/97	Cover, Contents Pages 1 — 70 New Manual Format, Contents, and Examples	2nd Edition
Rev. A	7/97	All sections	Text Corrections: Remove OP-DOSEDIT, Add DL350 notations
Rev. B	5/98	Manual Revisions Chapter 2 Appendix A-D	Rev. B Cut-out dimensions, added OP-2CBL-1 Minor changes

Table of Contents

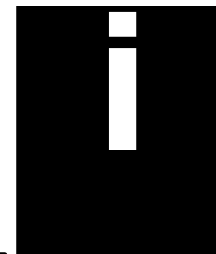

Chapter 1: Getting Started

Introduction	1-2
The Purpose of this Manual	1-2
Contents of the Manual	1-2
Supplemental Manuals	1-2
Technical Assistance	1-2
Chapters	1-3
Appendices	1-3
OP-1500 and OP-1510 Overview	1-4
Plan your System	1-4
General Panel Information	1-5
About the Pushbuttons	1-5
LCD Display Window	1-6
Keypad Entry	1-6
Annunciator Lamps	1-6
Back-Panel Layout	1-7
Serial Communications Port	1-7
Power Receptacle	1-7
Address Block	1-7
Access the Back Panel	1-7
Frequently Asked Questions	1-8

Chapter 2: Installation and Specifications

Preparing Panel Labels	2-2
Labeling the Lamps and Pushbuttons	2-2
Creating and Installing the labels	2-2
Template for Creating Labels	2-3
Dimensions for Mounting	2-4
Panel Specifications	2-5
Physical Specifications	2-5
Environmental Specifications	2-5
Operating Specifications	2-5
Connecting a Power Supply	2-6
Power Supply Connections	2-6
Multi-Panel Power Supply connection	2-6
Preparing the Panel for Configuration	2-7
Selecting Configuration Mode	2-7
Configuration Cable	2-7
Preparing the Panel for Communications	2-8
Assigning an Address	2-8
How to Set the Address	2-8
OP-9001 Multi-panel Configurations	2-8
The Termination Resistor	2-8
Choosing the Proper Connecting Cable	2-9



Connecting Cable Details	2-10
Connecting Cable	2-10

Chapter 3: Understanding the Features

Learning the Features	3-2
Status and Control Registers	3-3
Status and Control Register Overview	3-3
Bit Level Access	3-3
Status and Control Register Definition	3-4
Message and Menu Operations	3-5
Operator Panel	3-5
Messages	3-5
Static Messages	3-5
Dynamic Messages	3-5
Interactive Messages	3-5
Displaying Messages	3-6
Static Message Operation	3-6
Static Display	3-6
Dynamic Message Operation	3-7
Dynamic Message Top Line	3-8
Dynamic Message Bottom Line	3-9
Interactive Message Operations	3-10
Numeric keypad Entry	3-10
Arrow Adjustment Entry	3-10
Interactive Message Top Line	3-11
Interactive Message Bottom Line	3-12
Status and Control Bits used with Interactive Messages	3-13
Using the Data Available and Data Acknowledge Bits	3-13
Menu and Sub-Menus (OP-1510 Only)	3-14
Menu Items	3-14
Menu Operation	3-15
Using the Menu bits	3-16
Using Menu and Function Select bits	3-16
Pushbuttons and Lamps	3-17
Pushbutton Operation	3-17
Lamp Operation	3-17
Pushbutton Example	3-18
Pushbuttons Using Direct Access to Status Register bits	3-18
Pushbutton LEDs	3-18
Lamp Example	3-19
Lamp Flash	3-19
Memory Mapping Process	3-20
OP Base Register Memory Definition	3-20
Operator Panel Base Memory	3-20
DirectLOGIC User Memory Overview	3-22
Mapping Operation	3-23
Mapping Example (PLCDirect and Compatibles)	3-23
DL105/DL205/ DL405	3-23
DL105/DL205/ DL405	3-24



Mapping Example (PLC Direct DL305)	3-25
DL305 Family	3-25
DL305 (DL330/DL340 Only)	3-25
DL305 Only (DL330/DL340 Only)	3-26

Chapter 4: Configuring Your Operator Panel

Preparing for Configuration	4-2
Configuration	4-2
OPEditor Software	4-2
More about the OPEditor	4-3
OPEditor Documentation	4-3
System Requirements	4-3
How to Configure Your Panel	4-4
Step 1	4-4
Step 2	4-4
Step 3	4-4
Step 4	4-4
Step 5	4-5
Step 6	4-6
Step 7	4-6
Step 8	4-6
Step 9	4-6
Step 10	4-6

Chapter 5: Maintenance and Troubleshooting

Troubleshooting the OP-1500/1510 Panels	5-2
Troubleshooting	5-2
Panel Configuration Problems	5-2
Panel to PLC Communications	5-3
Allen Bradley Panel to PLC Communications	5-4

Appendix A: Application Worksheet

Application Worksheet Example	A-2
Application Worksheet Form	A-5

Appendix B: Application Examples

Example Scenario	B-2
DL105/DL205/DL350/DL405 Example	B-3

Appendix C: Application Examples

Example Senario	C-2
DL305 (DL330/DL340 Only) Example	C-3

Appendix D: Application Examples

Example Senario	D-2
Allen Bradley Example	D-3

Getting Started

1

In This Chapter. . . .

- Introduction
- OP-1500/OP-1510 Overview
- Frequently Asked Questions

Introduction

The Purpose of this Manual

This User Manual provides user information on panel installation, panel configuration, and programming the OP-1500 and OP-1510. The purpose of this manual is to teach concept and programming techniques which may be applied while implementing the OptiMate® panels. The example programming figures within Chapter 3 “Understanding the Features” use **DirectLOGIC™** program references for training purposes. Example programs for other PLC models and products are located in the Appendix B-D of this manual. Complete example programs are provided for **DirectLOGIC** and Allen-Bradley PLCs.

Contents of the Manual

Inside this manual you will learn about planning, implementing, and utilizing the OptiMate OP-1500 and OP-1510 products. This manual's contents discuss aspects of both OP-panels regardless of which PLC product you are connecting. Also included are application examples to improve the learning process and working knowledge with the OptiMate units.

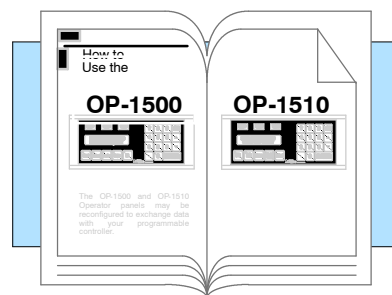

Supplemental Manuals

Reference the appropriate PLC/CPU User Manuals for the commands and address references required for your system. If you are using a **DirectLOGIC** PLC product, you will want to keep the **DirectSOFT** User Manual handy while programming your system. For *other* PLC brands you must reference their User manuals to properly program the ladder logic required to operate the OP-panels.

For Multi-Panel applications utilizing the OP-9001 Communications Master please refer to the OP-9001 User Manual (Part Number OP-9001-M).

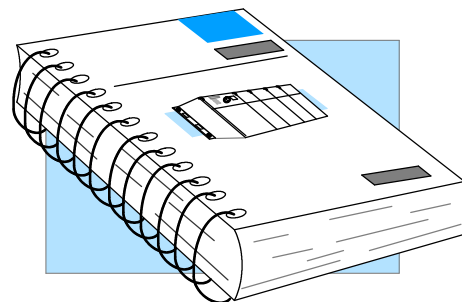

Technical Assistance

After completely reading this manual, if you are not successful with implementing the OP-1500 or OP-1510, you may call **PLCDirect** at (800) 633-0405, Monday through Friday from 9:00 A.M. to 6:00 P.M. Eastern Standard Time. Our technical support group will work with you in answering your application questions. If you have a comment or question about our products, services, or manuals which we provide, please fill out and return the suggestions card included with this manual.

Chapters

This table provides an overall description of the topics covered within this manual.



Getting Started

Introduces the physical and functional characteristics. Discusses the pushbuttons, lamps, LCD display and OP-1500 and OP-1510 characteristics. Also provides introduction to planning your system.



Installation and Specifications

Shows how to prepare for system installation, including specifications, and mounting instructions. Includes connecting cables part numbers and specifications.



Understanding the Basics

Detailed description of feature and functions available with OP-1500 and OP-1510. Teaches concept of how the data is exchanged between the OP and PLC. Also discusses the meaning of the Status and Control register bits used for asynchronous communications control.



Configuring Your Panel

Information on the differences between the DOS and Windows versions of OPEditor. The OP-WINEDIT for windows contains Help windows which will assist with configuring the OP-1500 and OP-1510.



Maintenance and Troubleshooting

Aid for diagnostics and maintenance of your OptiMate panel(s). Includes tips on isolating communications faults by use of LED status.

Appendices

Additional examples and reference information:



Application Worksheets

Application Worksheets for planning and creating OP-1500 and OP-1510 programs. These worksheets help define and implement the OP-panel pushbuttons, lamps, and messages.

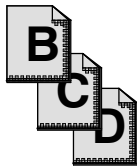

Complete Application Examples

Appendices B, C, and D provide complete example programs for using OP-panel standard functions and features. These examples will include compatible ladder logic for implementing pushbuttons, lamps, and messages using the DirectLOGIC compatibles and Allen-Bradley SLC5/03, SLC5/04 and Micrologic PLCs.



TIP: Information marked by this symbol indicates helpful hints about current topic.



WARNING: These markers warn you about specific concerns which may need to be addressed where there is a safety risk.



NOTE: This marker provides information which is important to check out.



DirectLOGIC PLCs : Denotes information specific to DirectLOGIC PLCs.



OTHER PLC'S : Denotes information specific to OTHER PLCs.

OP-1500/OP-1510 Overview

Plan your System Let's look at the OP-1500 and OP-1510 operator panels and their individually supported features. As you continue through this manual, try to relate the examples to your Operator Panel application. Use the *Application Worksheet* located in Appendix A, which will be helpful during the design and configuration stages of your system.

To help implement the OP-1500 and OP-1510 you should plan your system with all operator interface requirements in mind. All aspects of implementing the OP-panels are covered in the beginning chapters. It is important to read and understand all topics discussed before installing, configuring and programming your application.

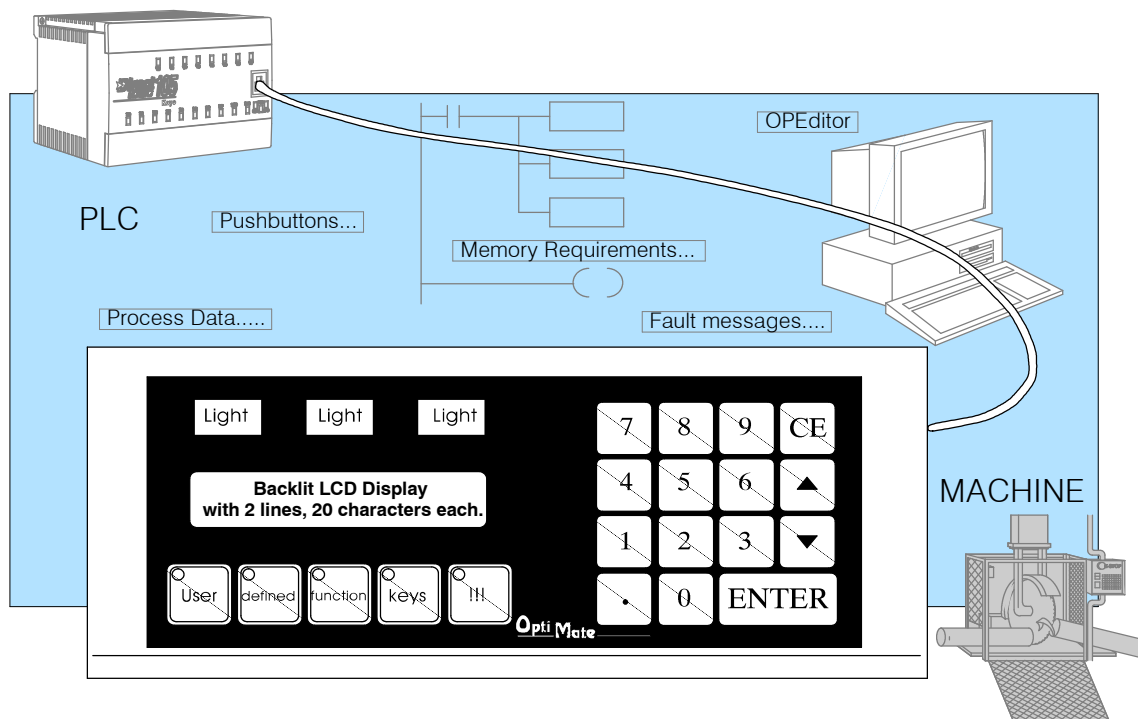

General Panel Information

The OP–1500 and OP–1510 Operator panels provide a man-machine interface to your PLC automation system. These panels are *not* designed for applications which demand large amounts of operator data entry. The OP–1500 and OP–1510 have very similar characteristics, but provide slightly different functionality. The OP-panel features such as lamps, pushbuttons, and messages are all discussed throughout this manual.

The Operator panels communicate with your PLC using either RS-232 or RS-422 serial communication. Details on configuration software and programming your operator panel are covered in later chapters. Your application requires either a Single or Multi-panel configuration. You may network up to 31 panels to a single PLC. For multi-panel systems, the OP-9001 Communication Master must be used.

For applications demanding large amounts of operator interface data or require information to be graphically displayed, we recommend using PC software such as Wonderware, LABview, Intellution etc. Please refer to our **PLCDirect** product catalog or contact one of our sales representatives for your Operator Interface solutions.

About the Pushbuttons

Many applications require Operator panel pushbuttons for controlling the machine or process. These pushbuttons are used for input signals to the PLC which start and stop a machine or process. The OP–1500 has five user configured pushbuttons and the OP–1510 has two user configured pushbuttons. You may create custom text labels describing the pushbuttons within your application. The following figures show the pushbutton layouts for the OP–1500 and OP–1510.

The OP–1500 contains five sealed membrane pushbuttons located on the lower left portion of the panel. All five pushbuttons may be freely defined for discrete input signals to the PLC. Configure these pushbuttons as momentary or alternating to best fit your operator interface application.

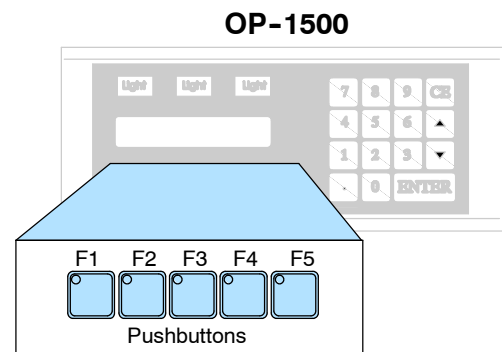

The OP–1510 contains two user-defined pushbuttons. These two pushbuttons may be configured as momentary or alternating type signals. The other three pushbuttons support the multi-layered Menu functions. The Menu pushbuttons allow you to perform the Menu operations and are clearly labeled Menu, Clear/Abort, and Select.

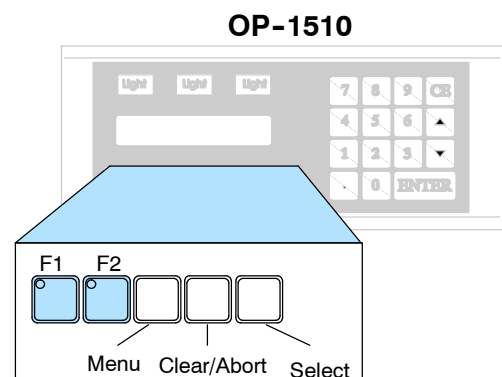

LCD Display Window

The OP-1500 and OP-1510 both feature a LCD display window. The LCD window supports two message lines which can display up to 20 characters each. The messages must be entered using configuration software which is referred to as OPEditor. Up to 160 messages may be configured and stored in the Operator panel. The message control type may be static text, dynamic, or interactive. The PLC logic program controls which messages are displayed. Details on how to implement and use the different types of messages are covered in later chapters.

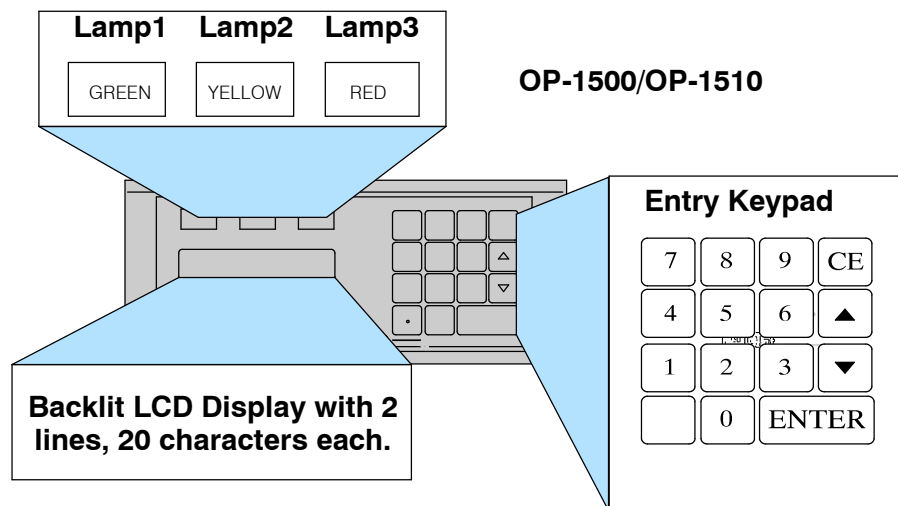

Keypad Entry

You may enter numeric values using the sealed membrane numeric keypad. Interactive messages are used to enter new setpoints using the keypad. During data entry, the keys labeled Enter, CE, ▲ (arrow-up), and ▼ (arrow-down), are also used to assist operator data entry functions. Use of Interactive messages are discussed in later sections of this manual.

Annunciator Lamps

The OP-1500 and OP-1510 each contain three annunciator lamps located above the LCD message window. From left to right these lamps are colored green, yellow, and red and may be labeled to fit your application. The lamps are turned on, off, and flashed through your ladder logic program.

Back-Panel Layout The back side of the OP-1500 and OP-1510 are typical in physical and functional characteristics. The panels both contain a serial port with transmit and receive LEDs, a power receptacle, and an address block with a termination switch.

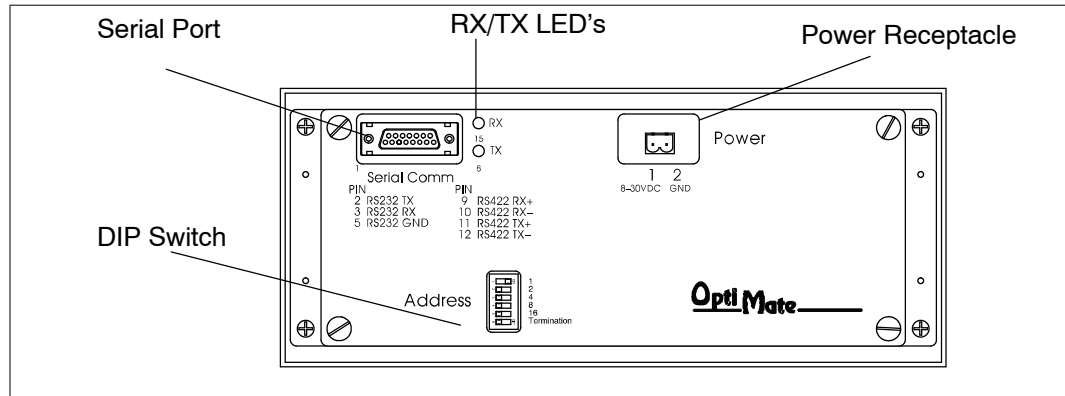

Serial Communications Port

The serial communications port is a 15-pin, female D-shell connector, which supports using RS-232 or RS-422 interface wiring. This port is used for communications between the OP-panel and PLC, as well as for programming your panel configurations. In the case of a Multi-panel application, this port may be connected to the OptiMate OP-9001 Communications Master.

Power Receptacle

The block style connector, also located on the back of the panel, is used to connect an external 24VDC power supply. This block style connector with screw terminals is provided with each panel and allows plug-in connection to the power receptacle.

Address Block

The address switch is for setting the panel address number (0-30) or selecting the panel configuration mode (address No. 31). The address block contains six switches which are discussed in Chapter 2, Installation and Specifications.

Access the Back Panel

The back of the OP-panel must be accessible for maintenance and programming purposes. For door mount installations allow minimum 5-inch depth behind the door for OP-panel clearance. This will include the 2-3 inches required for communications connector and cable. The next chapter discusses mounting specifications and cutout dimensions. Please refer to the Maintenance and Troubleshooting chapter in this manual for tips and techniques on troubleshooting.

Frequently Asked Questions

Q. What's new in this Second Edition Rev. A User's Manual?

A. The Second Edition OP-1500 and OP-1510 manual is divided into chapters for quick reference to information. This manual will help you understand and use features for both operator panels. Application Worksheets and programming examples are provided within the manual Appendices. It also defines the use of new Status bits (Up/Down arrows and Enter key bits).

Q. What is required to get started using the OP-1500 and OP-1510 in my application?

A. You must read this manual and understand the OP-panel requirements and application concepts. You must have programming knowledge for the PLC product you're using, the PLC serial communications capabilities which are available, as well as hook-up and connecting cable data. You should ensure the serial port, cables, and protocol parameters are properly chosen for the Optimate panel configuration you are programming.

Q. What's different between the OP-1500 and OP-1510 operator panels?

A. The OP-panels support typical features such as messages, pushbuttons, and lamps with exception the OP-1510 panel allows menu/sub-menu options. This menu/sub-menu feature is well-suited for systems which require extensive operator entry of setpoints and variable type data. The menu features occupy three pushbuttons to be used for handling the menu operations. Once again, you want to consider using the OP-1510 panel for applications which demand data entry of multiple variables or selection of multiple functions.

Q. How do I configure the OP-1500 and OP-1510 operator panels?

A. Using the OP-WINEDIT configuration software available from *PLCDirect*. This OPEditor software allows you to configure the OP-panels in a Microsoft Windows environment. You may configure your programs offline, upload, and/or download them to all your OptiMate panels. The OP-WINEDIT software is provided with installation documentation and Help screens.

Q. Can the OP-1500 and OP-1510 be used with other PLC products?

A. Yes. The Optimate units do support Allen-Bradley SLC 5/03, SLC 5/04, Micrologix, Modicon (MODBUS) and GE (CCM/SNP) PLCs. These applications are configured unique to that network and serial communication specifications supported with each different PLC product.

Q. Can I connect more than one OP-panel to one PLC/CPU?

A. Yes, this is referred to as a Multi-Panel application. You may network up to 31 panels to communicate using RS-422 multi-drop communications between the OP-panels and OP-9001 Communications Master unit. Also, if your CPU has secondary ports, you may connect a single panel to each available serial port.

Q. Will the OP-panels support graphics, animation, or color operator display screens?

A. No, the OP-panels which support display capabilities allow numeric data variable display, and some panels in addition will allow text message display on the 2-line 20-character LCD display window.

Q. Are the OP-panels compatible with the DL105 and other PLC products?

A. Yes, the OP-panels manufacturer date codes are located on the rear of the units. OP-panels manufactured from **October 1996** or later contain firmware which is compatible with **Direct**LOGIC PLCs, Allen-Bradley SLC 5/03, SLC 5/04, Modicon, and Micrologix PLCs. OP-panels manufactured from **October 1996** or later contain firmware version. For upgrade information contact your **PLCDirect** representative for details.

Q. Are OP-600 series panels compatible with the OP-9001 Master Controller applications?

A. Yes, the OP-9001 units manufacturer date codes are located on the rear of the unit. OP-9001 units which are date coded from **May 1997** or later contain firmware which is compatible with all OptiMate OP-1000 and OP-600 series panels. This firmware version is labeled on the IC chip and should be minimum of V2.4 or greater. For upgrade information contact your **PLCDirect** representative for details.

Q. Will the OP-600 series OP-panels support Allen-Bradley, MicroLogix, GE, or Modicon PLC applications?

A. No, the reduced size and cost of the OptiMate OP-600 series panels will not allow these panels to support all PLC types, as can the OP-1000 series panels.
*Supports all **Direct**LOGIC PLCs.

Installation and Specifications

In This Chapter. . . .

- Preparing Panel Labels
 - Template for Creating labels
 - Dimensions for Mounting
 - Panel Specifications
 - Connecting a Power Supply
 - Preparing Panel for Configuration
 - Preparing Panel for Communications
 - OP-9001 Multi-panel Configurations
 - Choosing the Proper Connecting Cable
 - Connecting Cable Details
 - Connecting Panel to PLC
-

Preparing Panel Labels

In any manufacturing environment, it is important to have legible markings on the lamps and pushbuttons. The lamp and pushbutton legends are different sizes and should be made separate for installation. You may create custom labels for your application. Use either the OP-WINEDIT Help screens template which allows label entry and printout, or use the templates provided on the following page.

Labeling the Lamps and Pushbuttons

Use the templates provided on the next page to create the labels on transparent film. The transparent film can be purchased from almost any office supply store in standard 8 1/2" x 11" sheets. It is designed to run through a copy machine or laser printer. The nicest legends result from using a computer graphics program and a laser printer to create the transparency. The labels slide into the top and bottom pockets of the Operator panel overlay. Use the following procedure to install the labels which are required for your application.

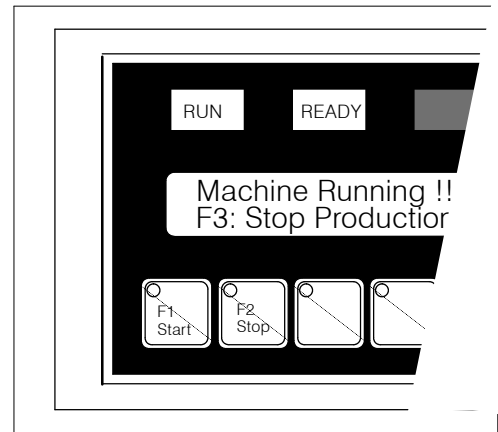

Creating and Installing the labels

1. Remove the front frame or bezel from the module by unsnapping the four plastic tabs which hold the bezel to the module frame.
2. Create legends for the top and bottom areas (lamps and pushbuttons). Once you have created the labels on transparent film, you can cut around the outside of each legend so that it fits into the pocket.

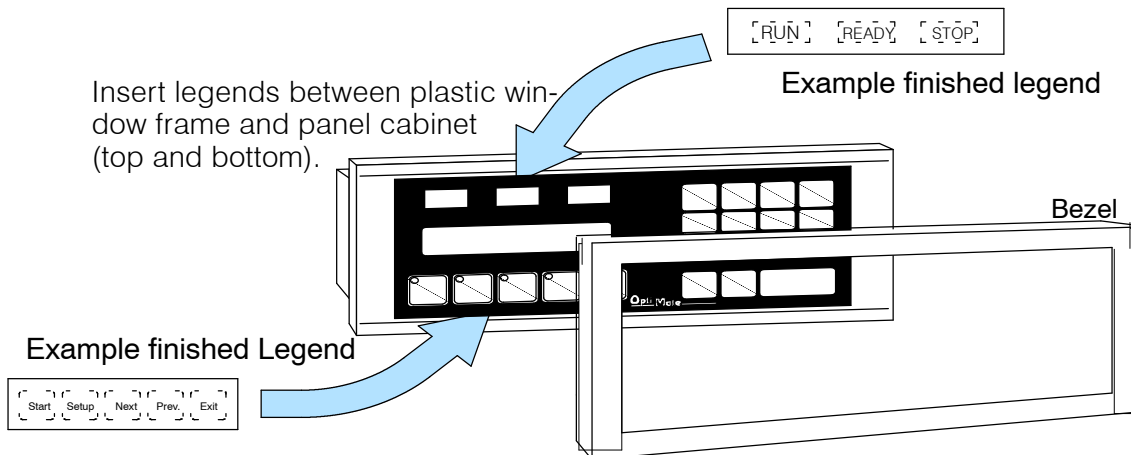

3. Use the pattern on the next page to cut out the legends from the transparency sheet.
4. Slide the finished legends into the pocket space between the front cover and the panel housing.
5. Re-attach the bezel by snapping the bezel onto the case.

Template for Creating Labels

a

Top Legend (Lamps)

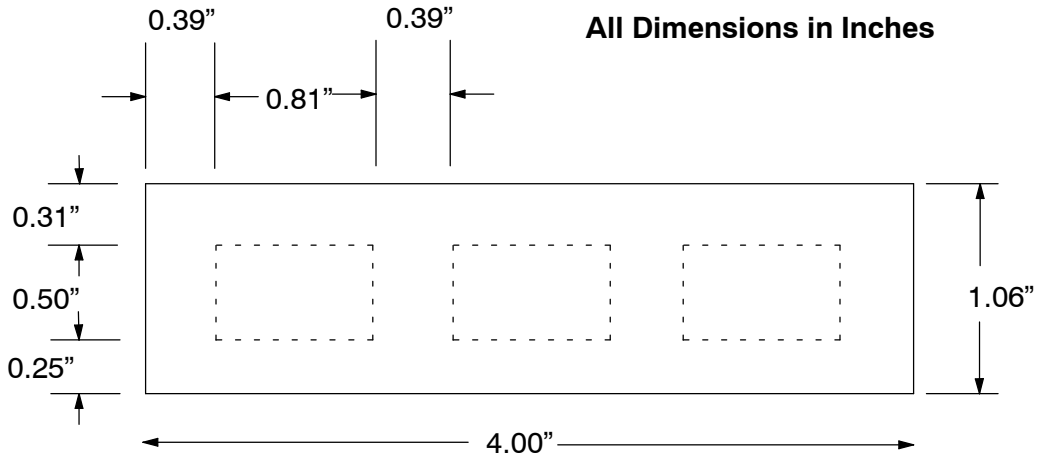

Bottom Legend (Pushbuttons)

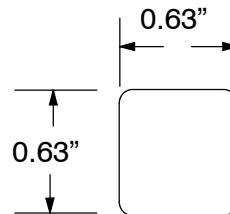
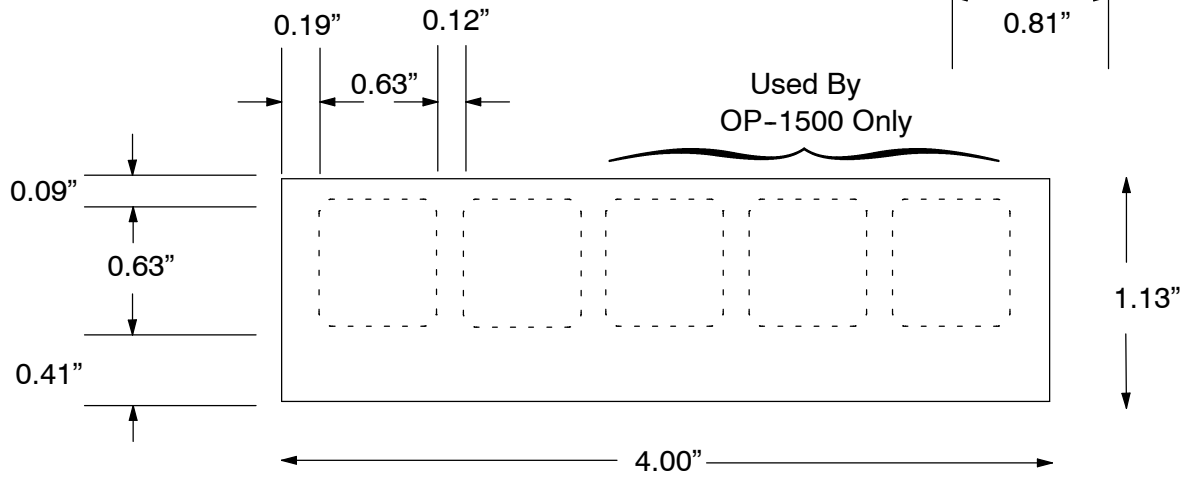

Dimensions for Mounting

Specifications

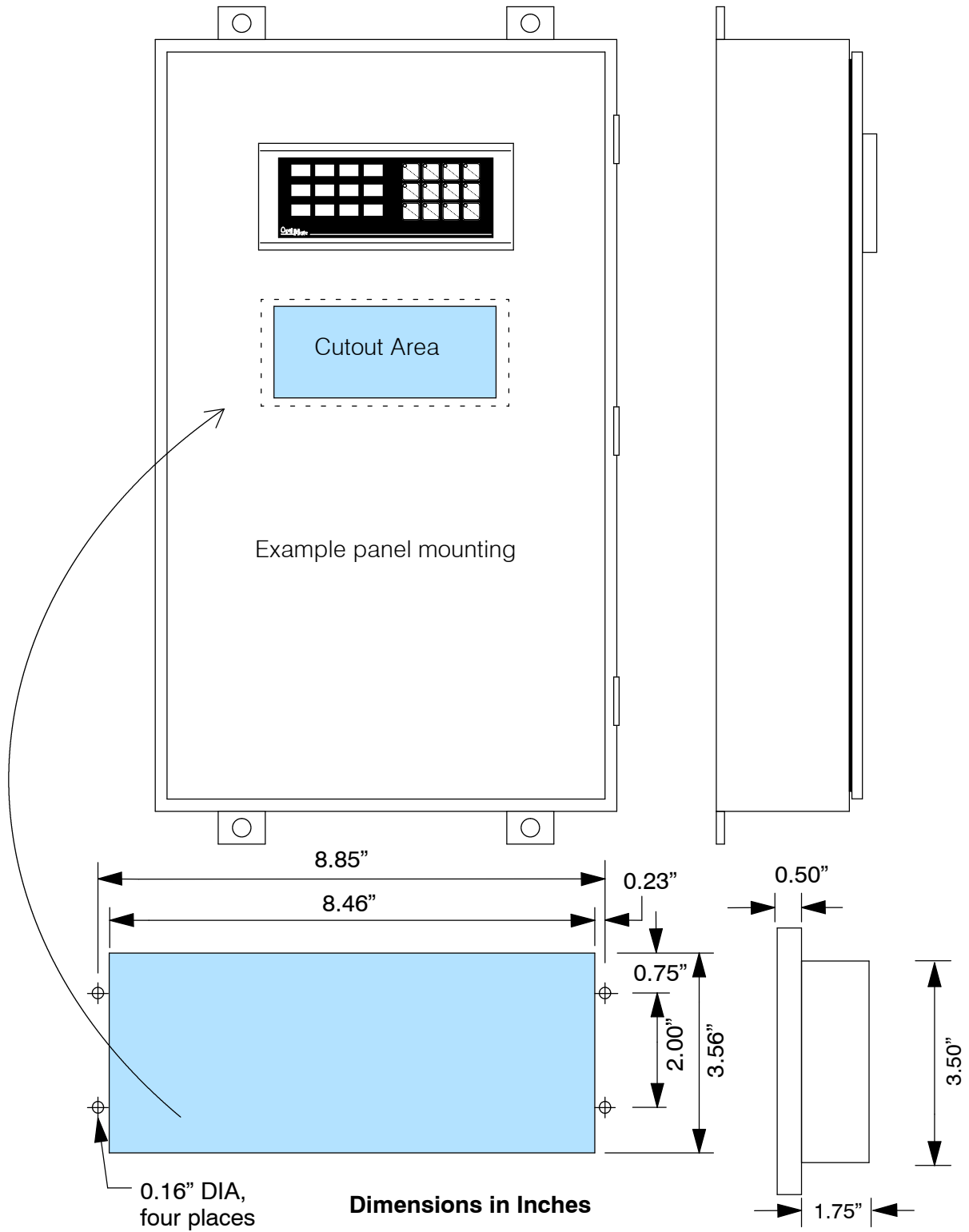

Panel Specifications

Physical

Specifications

Weight	19 ounces
Panel Fasteners	Four 6x32 threaded studs
NEMA Rating	NEMA 4 (when properly installed)

Environmental

Specifications

Operating Temperature	0° to 50° C
Storage Temperature	-20° to 80° C
Operating Humidity	5 to 95% (non-condensing)
Air Composition	No corrosive gases permitted

Operating

Specifications

Power Budget Requirements	5 VA @ 8-30 VDC 0.35 A @ 12 VDC (all LEDs OFF) 0.42 A @ 12 VDC (all LEDs ON) 0.18 A @ 24 VDC (all LEDs OFF) 0.21 A @ 24 VDC (all LEDs ON)
Power Connector	Keyed Terminal Block (2 position)
Minimum Supply Voltage	+8 VDC
Maximum Supply Voltage	+32 VDC
Diagnostics	LCD Operator Message, LED Status
Communication Link	RS-232 for distance less than 50ft RS-422 for distance up to 4000ft. 4800, 9600 and 19200* baud 15-pin female D type connector *19200 baud rates <i>will not</i> work with Allen-Bradley PLCs.
Connector Kits	OP-CMCON-1: pack of 4 ribbon cable connectors. OP-CMCON-2: pack of 4 solder type connectors. OP-CMCON-3: (2) D-Shell connectors w/ terminal block. (Multi-panel appl.) OP-PSCON: pack of 4-24VDC power supply connectors w/ terminals.

Connecting a Power Supply

Power Supply Connections

An external power supply is adapted to supply operating voltage to the OP-1500 and OP-1510 units. The power supply must deliver a range between 8 to 30 VDC, and provide a minimum of 5 watts continuous power to the units. Connect your power supply using the terminal block connector supplied with each panel. The connector is keyed to prevent reversing the polarity. Pin 1 is the positive connection (8-30VDC), while pin 2 is the common (0VDC) or ground connection.

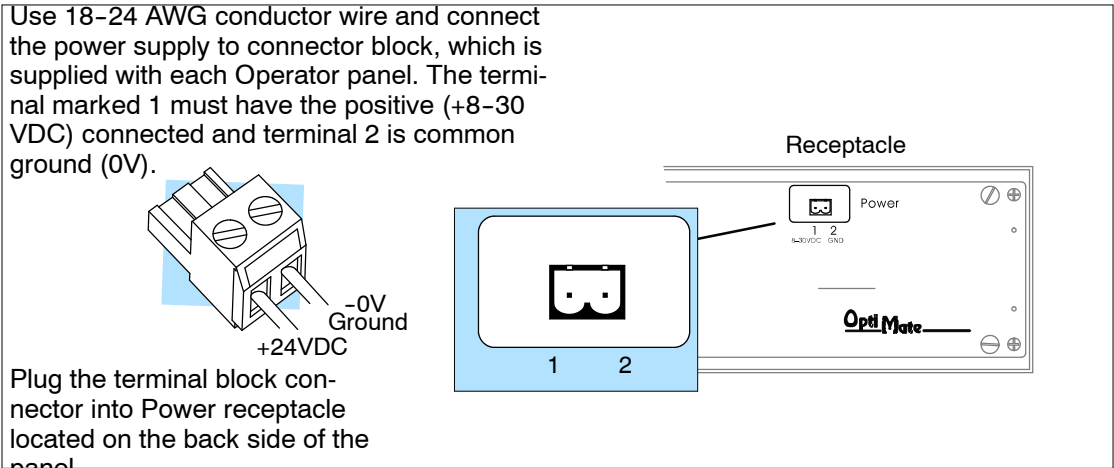

Multi-panel Power Supply connection

In Multi-panel applications, if separate power supplies are used, please ensure the electrical ground common do not have a great potential difference. For the use of a *single* power supply in a *Multi-panel* application, the supply must maintain the specified voltage and current consumption under all conditions (including power-up) for each of the individual units. See individual panel power requirements located on the previous page.

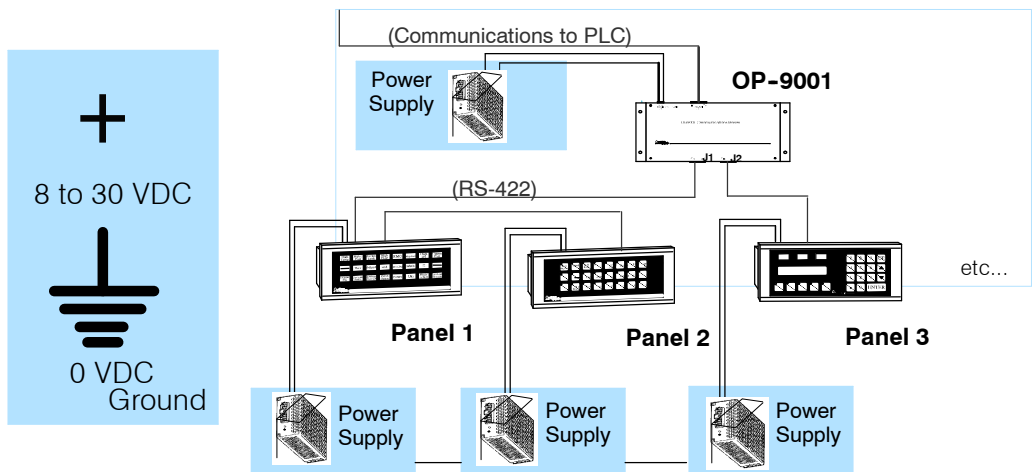

Preparing the Panel for Configuration

Selecting Configuration Mode



You may generate your operator panel configuration off-line. To download your configuration, the panel DIP switches must be set to address 31. Remove power from the OP-panel and set address 31 by sliding all switches 1 - 5 to the right most position (ON). The binary sum of all address switch values are the panel's address.

NOTE: Set the panel to address No. 31 for online configuration mode. Configuration mode allows download (write to panel) or upload (read from panel) application programs to your OP-1500 or OP-1510 panel.

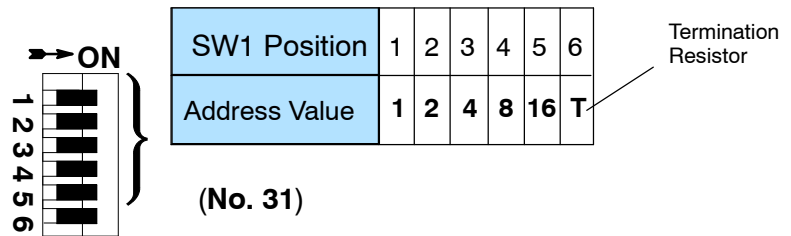

Specifications



NOTE: You must cycle power to the panel to activate the new switch settings.

Configuration Cable

Connect the configuration cable (OP-ACBL-1) between the serial port of the OP-panel and the serial port of the personal computer. The panels may then be configuring using the OP-WINEDIT configuration software. The figure below shows programming cable connectors and wiring specifications. Wiring diagrams refer to the cable connectors, *not* the communication ports.

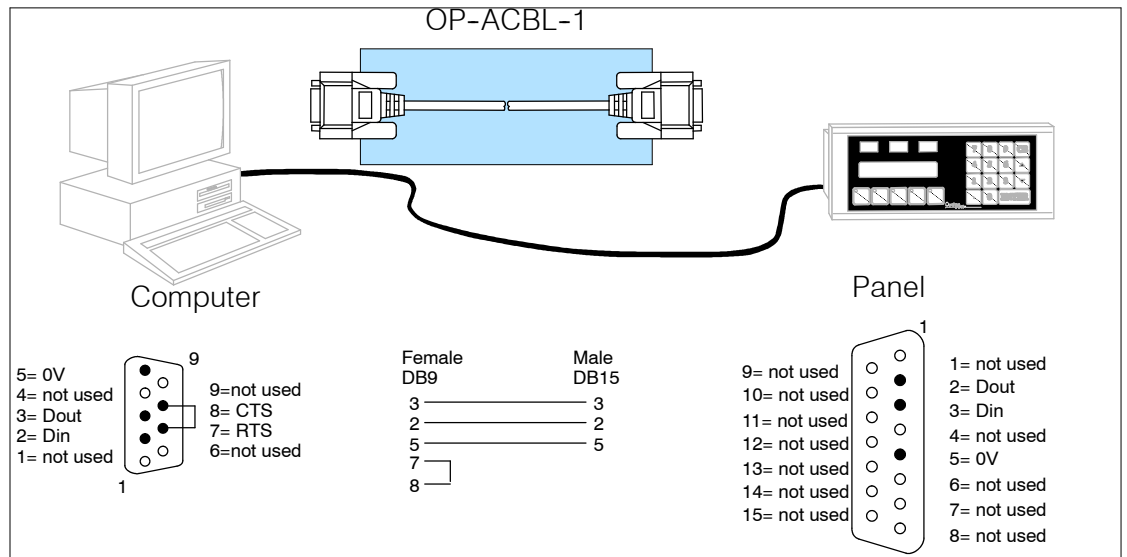

Preparing the Panel for Communications

Assigning an Address

You can assign any address between 0 and 30 for valid communications to the OP-9001 or CPU. The address is set with the DIP switch block located on the back of the units.

How to Set the Address

The address block contains six slide switches, switch 1 through 5 are used for addressing your Operator panel. The figure below shows the binary-weighted value of each switch. If you are using a single panel configuration, all addresses 0-30 are valid for communicating to the CPU. Remove power from the panel and change switches 1 through 5 to set the desired panel address.



NOTE: Set the panel address between 0-30 for valid communications mode.

In this figure we have selected address No.14, placed switches 2, 3 and 4 to the right (ON), and switches 1 and 5 to the left (OFF).

Example Address Block Setting

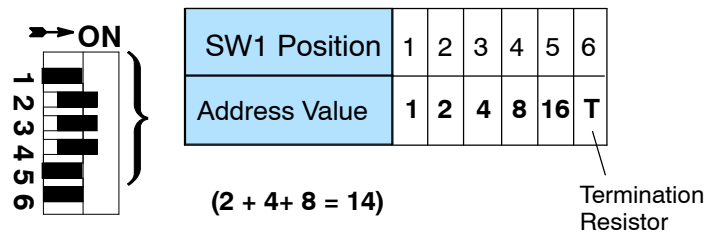

TIP: You must cycle power to the OP-panel to activate the new switch settings.

OP-9001 Multi-Panel Configurations

If you are connecting more than one OptiMate panel to a single CPU this is referred to as Multi-panel configuration. Multi-panel configurations require the OP-9001 Communications Master. The OP-9001 communicates with the CPU as well as the connected OP-panels. The OP-9001 Communications Master looks for an address within the range of 0 to 30 for each panel connected. Each panel connected in an RS-422 link must have a unique address. A more detailed description of multiple panel configurations and installation is given in the OP-9001-M User Manual.

The Termination Resistor

The last panel must be terminated when using an RS-422 communications link by setting switch 6 (ON). Operator panels communicating more than 50 feet distance *must* use RS-422 links. Systems which are using the OP-9001, in a multi-panel application use RS-422 wiring and properly set the terminating switch. Switch 6 is used for terminating an RS-422 communications link.



NOTE: Only the last panel of each RS-422 link should be terminated (switch 6 ON). All other panels must have switch 6 in the OFF position. After changing the DIP switch settings, remember to cycle power on the panel to activate the new switch settings.

Choosing Your Connecting Cables

Depending on which PLC you are using, you may require as many as two cables. Here are the requirements:

- **OP-ACBL-1:** *all* units require this cable for configuration. This is a 9-pin female to 15-pin male cable that connects your personal computer to the OP-panel. This cable is also used to connect an OP-panel to the Allen-Bradley SLC 500 CPUs listed.
- **CPU Cables:** You will also need the appropriate cable to connect your CPU to the OP-panel. Use the chart shown to the right to choose the correct communications cable.

OP-9001 Cable Connectors

If you're planning to use multiple panels and an OP-9001, then you'll need to build your own custom cables. Since the proper cable choice really depends on your application, we offer the following connectors.

- **OP-CMCON-1** — pack of 4 ribbon cable connectors.
- **OP-CMCON-2** — pack of 4 solder-type connectors.
- **OP-CMCON-3** — pack of 2 D-shell connectors with screw terminals for use with OP-9001 & multiple OP-panels.
- **OP-PSCON** — pack of 4 power supply block connectors.

For electrically noisy environments, we recommend an individually paired and shielded cable, such as Belden 9729 or equivalent. This type of cable will require the solder-type or D-shell with screw terminal connectors. If you're going 30 feet or less, you can use ribbon cable. For ribbon cable, we recommend Belden 9L28015 or 3M 3365/15.

OptiMate Cables			
Family	CPU (or other device)	Port	Cable
DirectLOGIC-DL105	DL130	Only port	OP-2CBL
DirectLOGIC-DL205	DL230	Only port	OP-2CBL
		Top port	OP-2CBL
	DL240	Bottom port	OP-2CBL
		DL250	Top port
	Bottom port	OP-2CBL-1	
DirectLOGIC-DL305	D2-DCM (module)	Only port	OP-4CBL-2
	DL330	Requires DCU*	OP-4CBL-2
	DL330P	Requires DCU*	OP-4CBL-2
	DL340	Top port	OP-3CBL
		Bottom port	OP-3CBL
DL350	Top port	OP-2CBL	
	Bottom port	OP-4CBL-2	
DirectLOGIC-DL405	DL430	Top port (15-pin)	OP-4CBL-1
		Bottom port (25-pin)	OP-4CBL-2
	DL440**	Top port	OP-4CBL-1
		Bottom port	OP-4CBL-2
	DL450	Phone Jack	OP-2CBL
		Top port (15-pin)	OP-4CBL-1
		Bottom port (25-pin)	OP-4CBL-2
	D4-DCM (module)	Only port	OP-4CBL-2
Slice I/O panels	Only port	OP-4CBL-1	
GE® Series 1	IC610CPU105/106	Requires DCU*	OP-4CBL-2
GE® Series- 90/30	All Models (311-351)	RS232, RS422 Serial Port	OP-GCBL-1
GE® Fanuc-Series 90 Micro	All Models	RS232, RS422 Serial Port	OP-GCBL-1
MODICON	ModBus	RJ45 port	OP-MCBL-1
TI305™ / SIMATIC® TI305-	325-07, PPX:325-07	Requires DCU*	OP-4CBL-2
	330-37, PPX:330-37	Requires DCU*	OP-4CBL-2
	325S-07 (or 325 w/ Stage Kt)	Requires DCU*	OP-4CBL-2
	330S-37, PPX:330S-37	Requires DCU*	OP-4CBL-2
	335-37, PPX:335-37	Phone Jacks	OP-3CBL
		If DCU is used*	OP-4CBL-2
TI405- / SIMATIC® TI405-	425-CPU, PPX:425-CPU **	Only port	OP-4CBL-1
	PPX:430-CPU	Top port (15-pin)	OP-4CBL-1
		Bottom port (25-pin)	OP-4CBL-2
	435-CPU, PPX:435-CPU **	Top port (15-pin)	OP-4CBL-1
		Bottom port (25-pin)	OP-4CBL-2
Smart Slice- I/O panels	Only port	OP-4CBL-1	
A-B SLC 500	5/03, 5/04	Bottom port	OP-ACBL-1
A-B	MicroLogix	Only port	OP-ACBL-2

* — requires RS232 Data Communications Unit (D3-232-DCU)

** — also DC versions

Connecting Cable Details

Connecting Cable The OP-1500/1510 connecting cable may vary depending on the CPU used. Refer to the previous page to confirm the proper cable is chosen for connecting your PLC.

Specifications

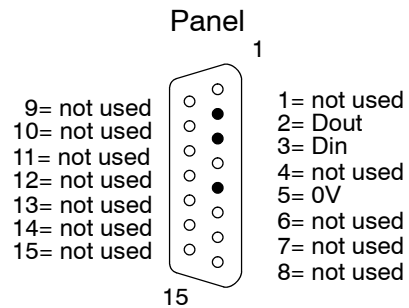
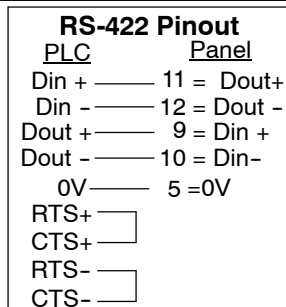
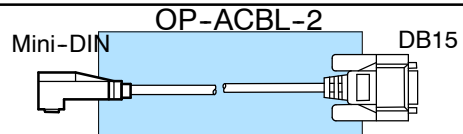
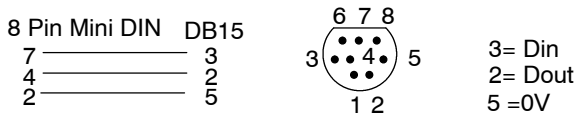
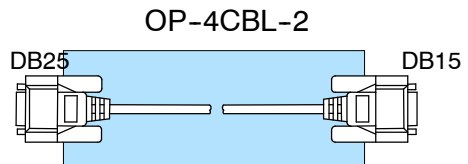
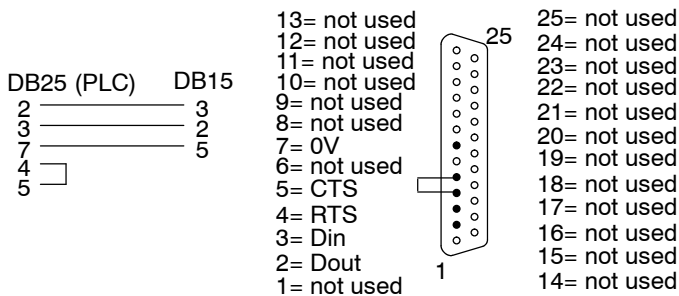
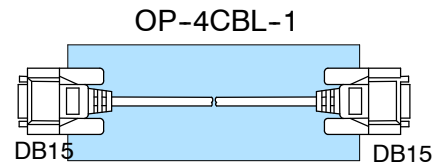
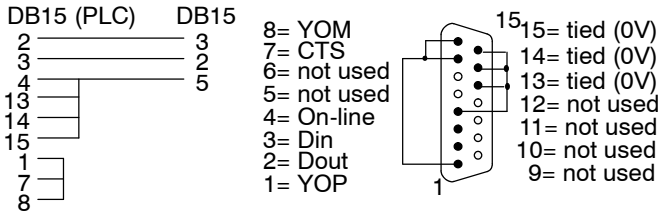
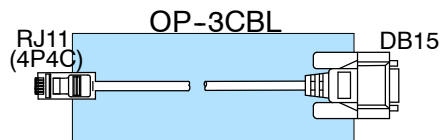
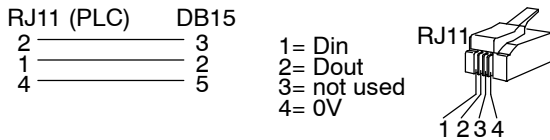
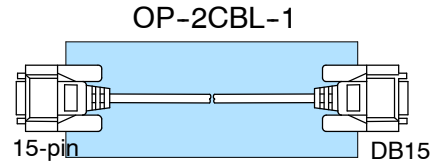
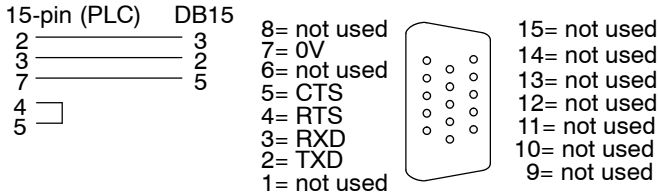
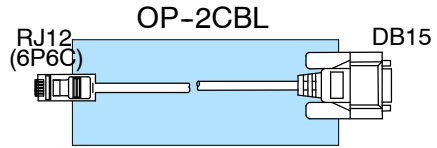
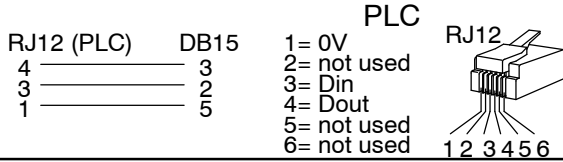

Understanding the Features

In This Chapter. . . .

- Learning the Features
 - Status and Control Registers
 - Message and Menu Operations
 - Displaying Messages
 - Menu Operations (OP-1510 Only)
 - Pushbuttons and Lamps
 - Memory Mapping Process
 - *Direct*LOGIC User Memory Overview
 - Mapping Operation
 - Mapping Example (DL105/DL205/DL350/DL405)
 - Mapping Example (DL330/DL340)
-

Status and Control Registers

Status and Control Register Overview

The OP-panels communicate to the PLC through user defined PLC data registers. The starting or “Base” register is assigned during panel configuration and automatically occupies eight consecutive 16-bit data registers. In this manual the registers are identified as m+0, M+1, m+2, thru m+7. Each OptiMate panel which is connected to the PLC maintains separate Status and Control registers within the PLC. These registers (m+6, m+7) contain information to monitor and control individual OP-panel functions and features. Shown in the figure below, base registers m+6 and m+7 **must have** bit level access by the user control program. That means Status and Control **word** register memory (OP-panel Base registers) must be mapped to user memory bit registers. These bit registers are referred to as Internal Control Relays such as C0, C1, etc.



TIP: Depending on which CPU is used and the Base memory which is assigned, the Status and Control registers *may not* require the mapping process.

Bit Level Access

Once again, the Status and Control bits are monitored and manipulated by the PLC ladder logic. For discrete operations such as pushbuttons and lamps, the registers m+6 and m+7 bits are accessed by the PLC control program. The figure below shows the fixed definition of the Status and Control register bits. These bits are labeled F1 (pushbutton 1), F2 (pushbutton 2), for example. The bits and associated labels are described on the following page. First examine the figure below to begin understanding the OP-panel registers and functions. You must structure your ladder logic program to coordinate OP-panel functions asynchronously. This means the operations are triggered successively—not by a clock, but by the completion of an operation.

Register	Function
m+0	Top line message selection
m+1	Bottom line message selection
m+2	Top line data/menu function
m+3	Decimal point, top line
m+4	Bottom line data
m+5	Decimal point, bottom line
m+6	Status register
m+7	Control register

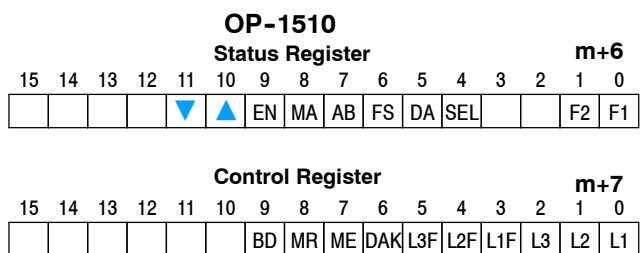
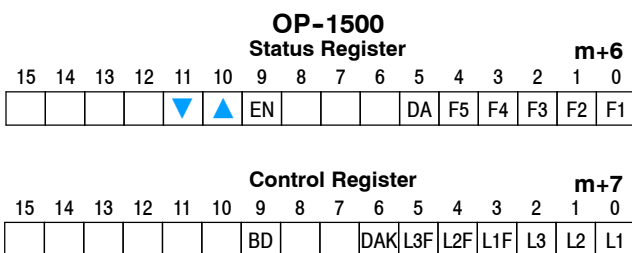

Status and Control Register Definition The Status register (m+6) and Control register (m+7) are used for data exchange between the OP-panel and PLC program. The figure below shows the individual bits within each data register. The function of the Status and Control register bits are described below.

Register	Function
m+0	Top line message selection
m+1	Bottom line message selection
m+2	Top line data/menu function
m+3	Decimal point, top line
m+4	Bottom line data
m+5	Decimal point, bottom line
m+6	Status register
m+7	Control register

Status Register (m+6):

F1-F5 - Are the status function for the OP-panel definable pushbuttons. These bits are set to 1 (ON) when the button is active. (F3-F5 OP-1500 only)

DA - Data Available is for data entry operations. The DA is set to 1 when new data has been entered, and ENTER key has been pressed.

SEL - Set to 1 when SELECT key is pressed. (OP-1510 only)

FS - Function Select. Indicates that a function has been selected through use of the menu tree. The function number will be held in register m+2. (OP-1510 only)

AB - Abort. Set to 1 when button pressed. (OP-1510 only)

MA - Menu Active. Set to 1 when menu button is pressed . Cleared when ME bit is reset. (OP-1510 only)

EN, ▲, ▼ - Numeric keypads Enter, Up arrow, and Down arrow button status. These status bits are set to 1 (ON) when button is active.

Control Register (m+7):

L1-L3 - Lamp ON/OFF control for each of the three annunciators. Set to 1 (ON) to turn the lamp on.

L1F-L3F - Lamp Flash control for each of the three annunciators. To flash the lamp set Lamp and Lamp Flash bits both to 1 (ON).

DAK - Data Acknowledge bit is used to clear the DA bit. When set the OP-panel will clear the DA bit and allow new data entry. This bit must be cleared after the DA bit is cleared.

ME - Menu Enable. Must be set for menu operation use. Your PLC control program should clear this bit when a menu function is selected.

MR - Menu Return. If set will return to same point in menu tree as when function was started. If reset, function complete will not return to the menu.

BD- Buzzer Disable. If set to 1 buzzer does not beep when buttons are pressed.

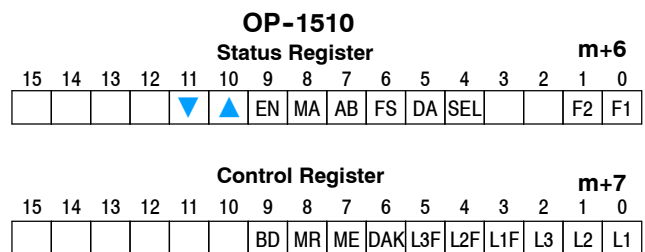
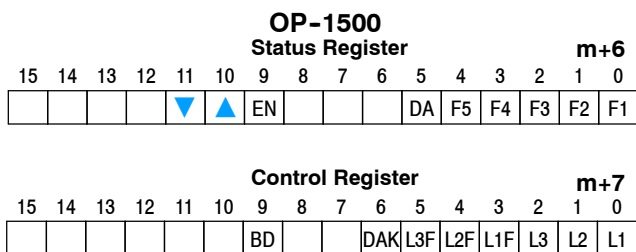

Message and Menu Operations

Operator Panel

Three primary categories, Static, Dynamic, and Interactive messages identify the different message types. The following pages provide an overview of these message types. Let's first study a few generic examples to describe the concepts of Message and Menu Operations.

Messages

As mentioned in earlier chapters, the LCD display supports two message lines with 20 characters each. Messages which may be displayed on either the TOP or BOTTOM display lines. These message types are referred to as **Static**, **Dynamic** and **Interactive**. The message type and operator control features are defined while using the OP-WINEDIT configuration software. Let's have a closer look at the different messages supported by the OP-1500 and OP-1510.

Static Messages

Static messages are text displays which have *no* embedded data. The Static messages may be displayed when an event or condition becomes true. You enter the messages using the OPEditor software during configuration.

Example Static Message:

SYSTEM RUNNING

Dynamic Messages

Dynamic messages are text messages which include embedded data. These messages are used to present the operator with important PLC data. This data is information which helps the Operator closely monitor and/or control the machine or process.

Example Dynamic Message:

Zone1 Temp SP: ^^^^

Data Value update from PLC register

Interactive Messages

An Interactive message is commonly used for prompting the operator for data entry. You will use this type of message for changing values which are stored in the PLC registers. These values are items such as setpoints, upper and lower limits etc...

Interactive messages may be configured to enter data using either the arrow UP/DOWN keys or NUMERIC KEYPAD.

Interactive Message:

Enter New Temp. = ^^^^

Data Value entered by Operator

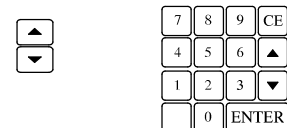

TIP: While configuring Static messages the operator control parameters *do not* need to be changed in the OPEditor. The message operator control parameters default for **Display Only**.

Displaying Messages

The logic required to display the configured message is quite simple. You need only put the message number (1-160) in memory location **m+0** for the top line message or **m+1** for the bottom line message. The figure below demonstrates an example of a Static message.

Static Message Operation

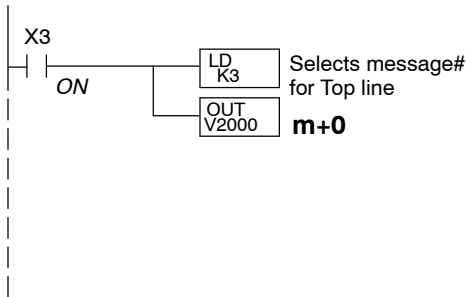

In this example, if the PLC's input signal X3 is ON, the 16 bit integer (K3) value is placed in Word register V2000 (m+0) selecting message #3 to be displayed on the top line.

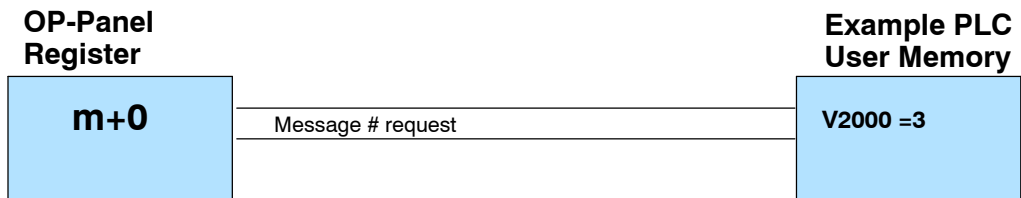

Static Display

Description

All supported CPUs use the first OP-panel register for displaying a Top line Static message. Your ladder logic program must sequence the message being displayed by placing an integer value (1-160) in register m+0. For Bottom line Static messages use register m+1 for message selection. The OP-panel operating system automatically updates the latest Top and Bottom line messages according to values placed in the highlighted registers.

Top Line Static Message

Register	Value	Function
m+0	3	Top line message selection
m+1		Bottom line message selection
m+2		Top line data/menu function
m+3		Decimal point, top line
m+4		Bottom line data
m+5		Decimal point, bottom line
m+6		Status register
m+7		Control register

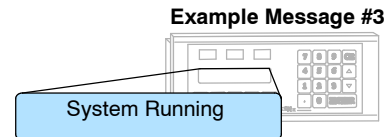

Dynamic Message Operation

Dynamic displays are text messages which include embedded data. These messages present the operator with important PLC data. The following paragraphs describe how to program Dynamic messages.

You may program message numbers 1-160 to be used as dynamic messages. Dynamic messages may be displayed on either the top or bottom display lines. The maximum number of digits which may be displayed is five (if binary data format or four if BCD). The figure below demonstrates the OPEditor screens for programming a Dynamic message.

Use the OPEditor to configure Dynamic messages. Enter the message text and place the caret (^) symbol(s) depending on number of digits you would like to display. The value range which may be displayed is 0-65,535 integer or 0-9999 BCD (Binary Coded Decimal). Choose binary or BCD format and decimal placement of either Variable Point or Fixed position. When choosing the data format for **DirectLogic** PLCs use BCD format, and with Allen-Bradley PLCs use Binary.

For Dynamic messages which require decimal point placement within the value, you must use the OPEditor to perform parameter placement type. For fixed position decimal points you must enter the decimal directly into the message text, such as Zone1 Temp SP= ^^.^.

For displaying Variable Point numbers in a Dynamic message, the decimal is controlled with base register m+3. The m+3 values are controlled within the PLC program.



TIP: For Dynamic messages, you must configure the data format and decimal point characteristics. During configuration use the caret ^ symbol to mark the data position and length. The Operator Control parameter must also be changed to match the type and format of the data which is displayed.

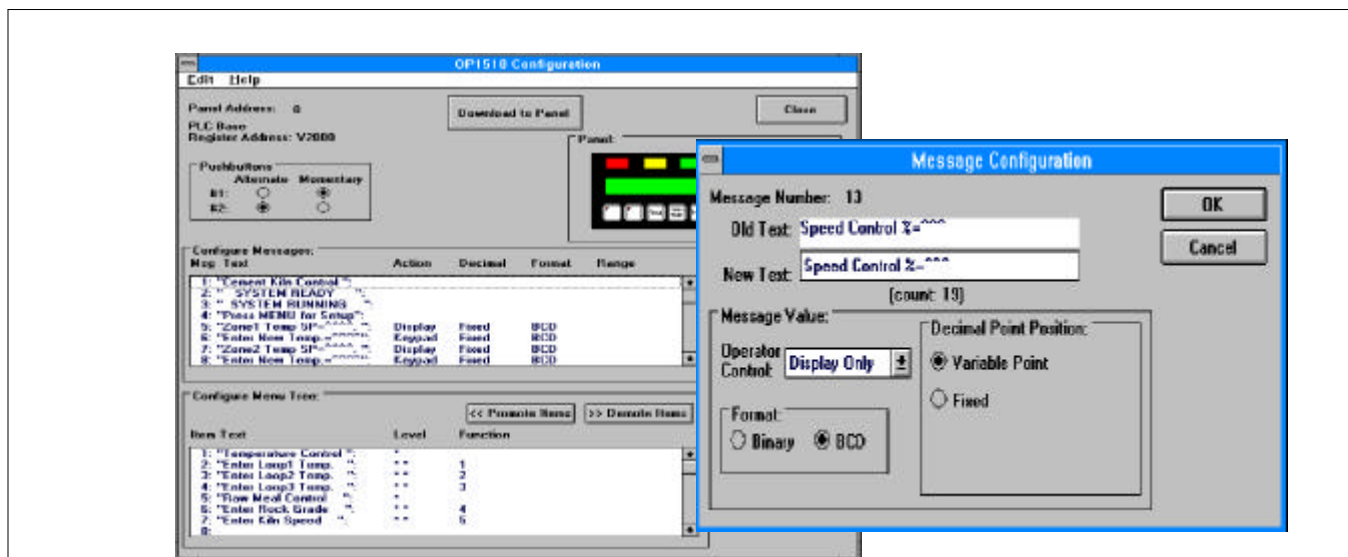

Dynamic Message Top Line

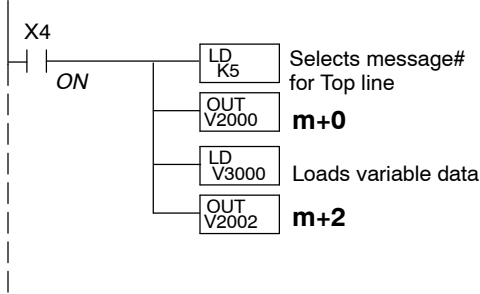

In this example, if the PLC's input signal X4 is ON, the 16 bit integer (K5) value is placed in Word register V2000 (m+0) selecting message #5 to be displayed on the top line. The data value in register V3000 is moved into V2002 (m+2) such as 1100, which is embedded in the top line message. The Top line data value will be update as long as X4 is enabled (ON).

OP-Panel Register

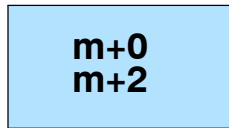

Example PLC User Memory

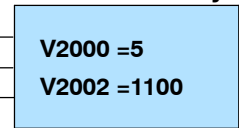

Message # requested
Top line message data

Description

Regardless of which PLC product you are using, the following concept applies to top-line Dynamic messages.

Your ladder logic program must select the message being displayed by placing an integer value between 1 and 160 (message #) in register **m+0**. The embedded data for the top line message is controlled by loading a 16 bit value into register **m+2**. The highlighted registers in this figure result in displaying this top-line Dynamic message.

Top Line Dynamic Message

Register	Value	Function
m+0	5	Top line message selection
m+1		Bottom line message selection
m+2	1100	Top line data/menu function
m+3		Decimal point, top line
m+4		Bottom line data
m+5		Decimal point, bottom line
m+6		Status register
m+7		Control register

Example Message #5

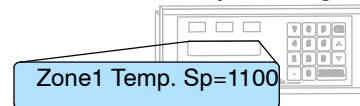

Dynamic Message Bottom Line

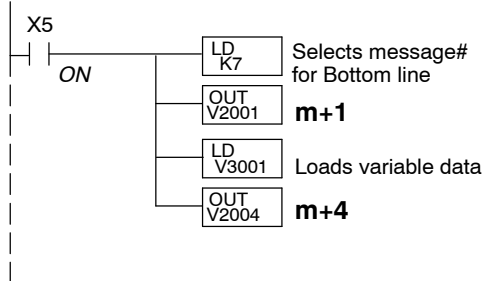

In this example, if the PLC's X5 input signal is ON, the 16 bit integer (K7) value is placed in Word register V2001 (m+1) requesting message #7 to be displayed on the bottom line. The data value in register V3001 is moved into V2004 (m+2) such as 1101, which is embedded in the top line message. The Bottom line data value will update as long as X5 is enabled (ON).

OP-Panel Register

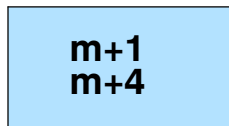

Example PLC User Memory

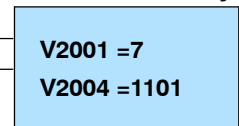

Message # requested

Description

Regardless of which PLC product you are using, the following concept applies when using bottom line Dynamic messages.

Your ladder logic program must select the bottom line message being displayed by placing an integer value between 1 and 160 (message #) in register **m+1**. The highlighted register shown in this figure results in displaying this bottom-line Dynamic message.

Bottom Line Dynamic Message

Register	Value	Function
m+0		Top line message selection
m+1	7	Bottom line message selection
m+2		Top line data/menu function
m+3		Decimal point, top line
m+4	1101	Bottom line data
m+5		Decimal point, bottom line
m+6		Status register
m+7		Control register

Example Message #7

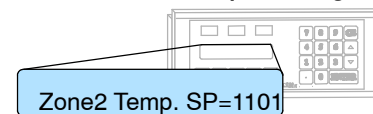

the Features

Interactive Message Operations

An Interactive message is a text display which requires operator data entry. Use these messages to enter or change values which are stored in PLC registers. Five digits may be entered in a 16-bit register using binary data format. When the interactive message is displayed the operator will be required to enter data. Check the proper PLC product user manual to verify which data formats are supported. Depending on which PLC product is used, the data format will be either binary or BCD(Binary Coded Decimal). For example, with *DirectLogic* PLCs the BCD format is commonly used, and Allen-Bradley PLCs commonly use binary. The figure below describes the requirements for configuring an Interactive message.

Interactive messages are configured within the OPEditor Message Configuration screen. An interactive message requires that you define the **Operator Control** (Numeric keypad or Arrow keys), **Format** (Binary or BCD), and **Decimal Point Position** (Fixed or Variable Point). If your interactive message requires decimal points, you must choose the operator control decimal point type. There are two types of decimal point placement which are Variable Point and Fixed placement. For **Display Only** variable point data, your control program should examine the integer value 1 through 4 in m+3 for top line, m+5 for bottom line, which will determine the place locator for decimal point. For Variable decimal points *do not* enter the decimal within the message, but enter an extra caret ^ symbol in addition to the number of digits. The variable point is then controlled by the PLC using the top and bottom line decimal point registers (m+3, m+5). For fixed decimal entries the decimal point is entered directly into the Interactive message text.

TIP: For Interactive messages, you must configure the Operator Control (arrow Up/Down or Numeric keypad), select the data format (Binary or BCD) and decimal point characteristics (fixed or floating). While configuring the Interactive message, use the caret (^) symbol for each numeric digit required within the text message.

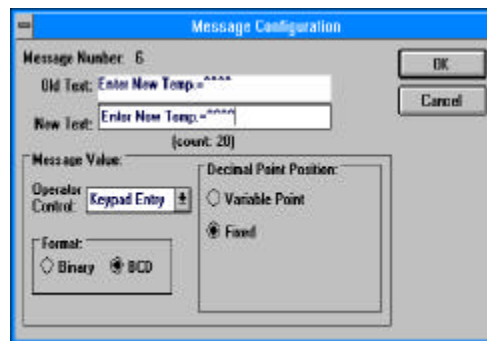

Numeric keypad Entry

When an Interactive message value is entered and you press the Enter key, the value will be placed in OP-panel data register, and the Status register DA (Data Available) will be set. The DA bit will remain on until a new message is placed in register m+0 or m+1, or until the DAK (Data Acknowledge) control bit is set.

Arrow Adjustment Entry

Arrow adjust is commonly used when minimum and maximum setpoint ranges are required or setpoint value requires only minor adjustment. The arrow adjustments are only possible using the Arrow UP/DOWN Keys. As you press the up and down arrow keys the numeric value will increment and decrement respectively, one count at a time. When the adjustment is complete and you press the Enter key, the value will be placed in data register m+2 or m+4 (top or bottom line data) for display, and the DA status bit is set. The DA bit will be set until a new message is displayed or the DAK control bit is set.

Interactive Message Top Line

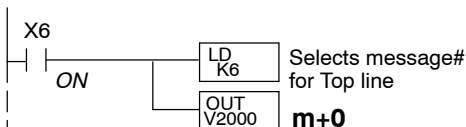

In this example, if the PLC's X6 input signal is ON, the 16-bit integer (K6) value is placed in Word register V2000 (m+0) requesting message #6 to be displayed on the top line.

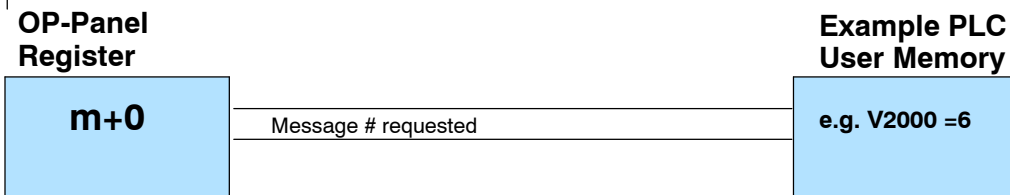

Description

Regardless of which PLC product you are using, the following concept applies when using top-line Interactive messages. Your ladder logic program must select the top line message being displayed by placing an integer value between 1 and 160 (message #) in register **m+0**. The highlighted register shown in this figure results in displaying this Top Line Interactive message.

Top Line Interactive Message

Register	Value	Function
m+0	6	Top line message selection
m+1		Bottom line message selection
m+2		Top line data/menu function
m+3		Decimal point, top line
m+4		Bottom line data
m+5		Decimal point, bottom line
m+6		Status register
m+7		Control register

Example Message #6

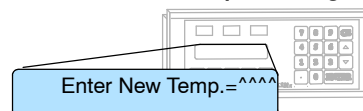

WARNING: With the OP-1510, if an Interactive menu message is selected, you may press the Clear/Abort key to escape the data entry process. In the case you *do not* enter new data, but press the ENTER key, the OP-panel will automatically load zeros into the data entry buffer.

Interactive Message Bottom Line

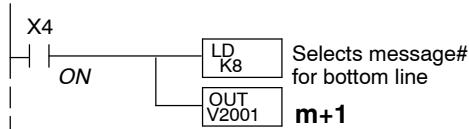

In this example, if the PLC X4 input signal is ON, the constant K8 16-bit integer value is placed in Word register V2001 (m+1) requesting message #8 to be displayed on the bottom line.

OP-Panel Register

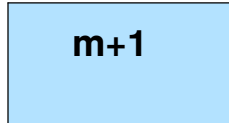

Example PLC User Memory

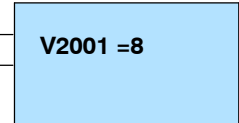

Message # requested

Description

Regardless of which PLC product you are using, the following concept applies when using bottom line Dynamic messages.

Your ladder logic program must select the bottom line message being displayed by placing an integer value between 1 and 160 (message #) in register **m+1**. The highlighted register shown in this figure results in displaying this bottom line Interactive message.

Bottom Line Interactive Message

Register Value	Function
m+0	Top line message selection
m+1	8 Bottom line message selection
m+2	Top line data/menu function
m+3	Decimal point, top line
m+4	Bottom line data
m+5	Decimal point, bottom line
m+6	Status register
m+7	Control register

Example Message #8

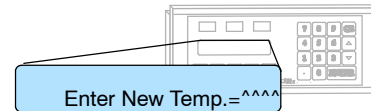

Status and Control Bits used with Interactive Messages

The circled registers in the figure below are required when using an **Interactive message**. As described in earlier chapters, the Interactive messages pass data values between the OP-panel and the PLC. The data exchange is coordinated with the **Data Available (DA)** and **Data Acknowledge (DAK)** bits.

Register	Function
m+0	Top line message selection
m+1	Bottom line message selection
m+2	Top line data/menu function
m+3	Decimal point, top line
m+4	Bottom line data
m+5	Decimal point, bottom line
m+6	Status register
m+7	Control register

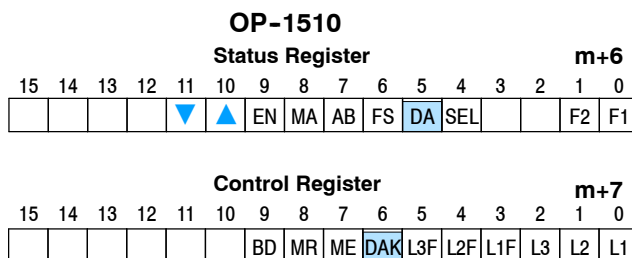
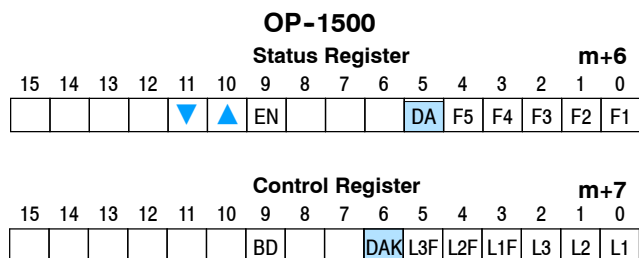

Using the Data Available and Data Acknowledge Bits

The **DA** (Data Available) register, bit number 5 of the Status word, is controlled by the OP-1500 and OP-1510 operating system. This bit is turned on after the operator has entered a numeric value and pressed the ENTER key. Your ladder logic should monitor the DA bit to trigger the storage of the entered data. Use the DA bit to turn ON the Data Acknowledge (**DAK**) bit within your control program. The DAK bit is confirmation to the OP-panel from the PLC which completes handling the Interactive message.

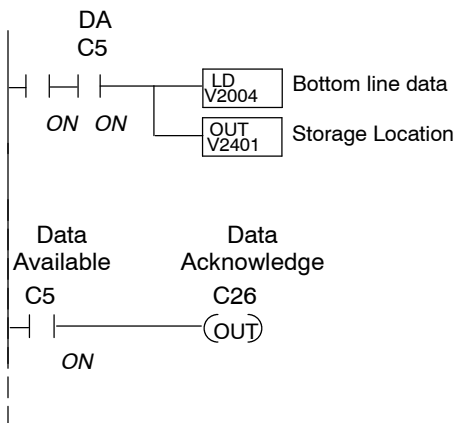

In this example, C5 represents the Data Available bit. When C5 is ON then C26 Control relay is energized.

- * Status Register (m+6) = V40600: C0 - C17
- * Control Register (m+7) = V40601: C20 - C37

Menu and Sub-Menus (OP-1510 Only)

The OP-1510 supports Menu and Sub-Menu functions to select and change register values in your PLC. You may have up to four levels of Menu/Sub-Menu functions. Plan your Menu structure according to your operator interface requirements. You should structure the menu tree to allow operator access to information which is most often used, and the sub-menu operations accordingly.

Your Menu Plan

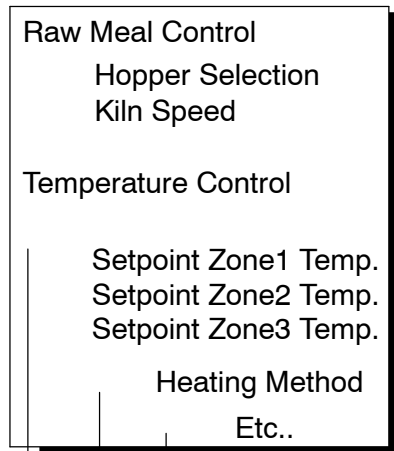

You configure your menu and sub-menu items using the OPWINEDIT software. Each menu item is assigned an Item Level (1-4) as well as type which determines if the menu message selects a sub-menu or function. Menu items which are configured as Functions allow the operator to select and perform user defined interaction. Use the OP-WINEDIT on-line help for more details on how to configure a menu functions.

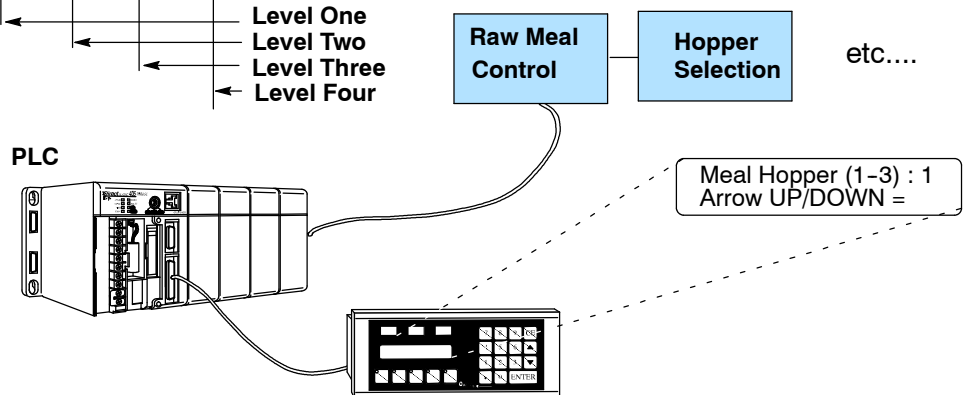

Menu Items

Configure your menu and sub-menu items using the OP-WINEDIT software. Each item number must have an Item Level (1-4) as well as Item Type which determines whether the menu message is a sub-menu or function. Menu items which are configured as functions allow the operator to SELECT and initiate interactive operator actions.

Your ladder logic program controls the Menu Enable (**ME**), and Menu Return (**MR**), bit 7 and 8 of Control word m+7, to help coordinate these menu functions. The following pages help provide a clear understanding of the Status and Control bits which are affected while using the **Menu/Sub-Menu** functions.

Menu Operation

The OP-1510 has four additional bit functions (**AB**, **FS**, **MR**, and **ME**) which are defined within the status and control registers. These are not available with the OP-1500. The **Clear/Abort** key on the panel energizes the **AB** flag, and you can use your ladder logic to have it trigger any type of action, such as abort a function. The **FS** bit is set when you select a function via the menu. The **ME** bit enables the menu so that when you press the **Menu** key, it will display the menu. Otherwise, if you push the Menu key, nothing will be displayed. If you reset the **ME** bit to zero (0), the menu is disabled and you can perform functions or enter values, depending on how you have written your ladder logic. When the **Menu Return (MR)** bit is energized (ON) with the ME bit also energized (ON), you will be *returned* to the menu or sub-menu which was displayed, when completing the function select process by entering data and pressing the Enter key. If you do not use the **MR** bit, the OP-1510 will not automatically return into the menu.

Register	Function
m+0	Top line message selection
m+1	Bottom line message selection
m+2	Top line data/menu function
m+3	Decimal point, top line
m+4	Bottom line data
m+5	Decimal point, bottom line
m+6	Status register
m+7	Control register

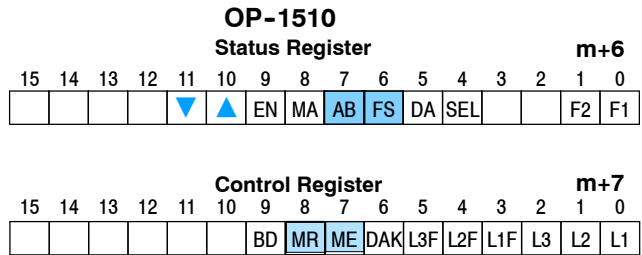
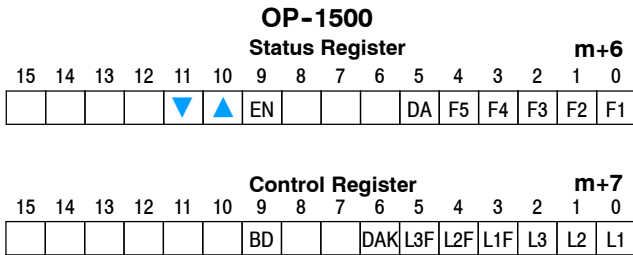

Using the Menu bits

Your ladder logic program must energize the **ME** (Menu Enable) bit within the Control register. When the ME bit is ON the operator may use the Menu, Clear/Abort and Select keys located on the OP-1510. With the ME enabled, you may view and SELECT the configured menus being displayed by the OP-panel. Use the arrow Up/Down keys to scroll the configured menus. While the ME bit is energized the register m+2 maintains the Menu function number. If a particular function is chosen with the **Select** key, the OP panel energizes the **Function Select (FS)** bit in Status register (m+6). When your program sees the FS bit set, it should decode the function number placed into register (m+2), clear the ME bit and execute the selected function.

Register	Function
m+0	Top line message selection
m+1	Bottom line message selection
m+2	Top line data/menu function
m+3	Decimal point, top line
m+4	Bottom line data
m+5	Decimal point, bottom line
m+6	Status register
m+7	Control register

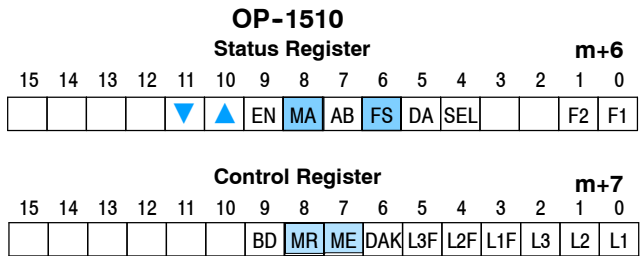
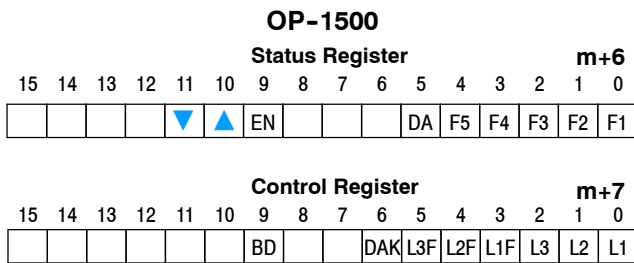

Using Menu and Function Select bits

If the Menu Enable bit is ON and the Select key is pressed, the Function Select bit is set (FS=1) which enables the proper data entry (function) to operate. The ME bit should be set OFF until the function is complete. The interactive menu operation is performed using the DA and DAK bits as mentioned on the previous page. This bit-handling operation is asynchronous and requires your ladder logic to coordinate Menu Enable and Function Select tasks. After completing the operation you must set the ME bit ON, to begin the next menu function. Examples provided later will help you better understand these operations.

Pushbuttons and Lamps

The OP-1500 and OP-1510 both contain user-defined pushbuttons and lamps. Pushbuttons may be used to begin events or tasks within the PLC, such as start/stop control. The following pages describe concepts of how to monitor and control the pushbuttons and lamps on your OP-panel.

Pushbutton Operation

The OP-panel pushbutton inputs are monitored for ON/OFF conditions in your PLC ladder logic program. From a practical point of view we need to control and monitor the bits in the status and control registers on an individual basis. The OP-1500 pushbuttons are assigned to the *first five bits* of the **Status Register (m+6)**. The OP-1510 has two pushbuttons and are defined as the *first two bits* within the **Status Register (m+6)**. Examine the highlighted Status bits below which show each user definable pushbutton.

Lamp Operation

The lamps on both of the OP-panels may be user defined to display status or condition of any operation being controlled within the PLC. The lamp usage may differ from application to application. Concepts of programming and using the individual lamps and flash features are shown below. The green, yellow and red lamps on both panels are controlled by the *first six bits* of the Control Register (m+7). The first control register bits (L1, L2, and L3), are used to illuminate the individual lamps ON/OFF status. The next three bits (L1F, L2F, and L3F) control the flashing option for each of the three lamps. In an actual application, the lamp bit must be turned on before the lamp flash bit is energized.

Register	Function
m+0	Top line message selection
m+1	Bottom line message selection
m+2	Top line data/menu function
m+3	Decimal point, top line
m+4	Bottom line data
m+5	Decimal point, bottom line
m+6	Status register
m+7	Control register

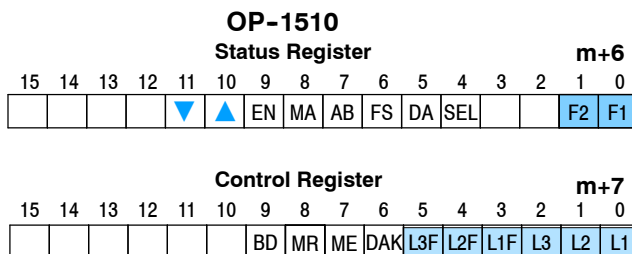
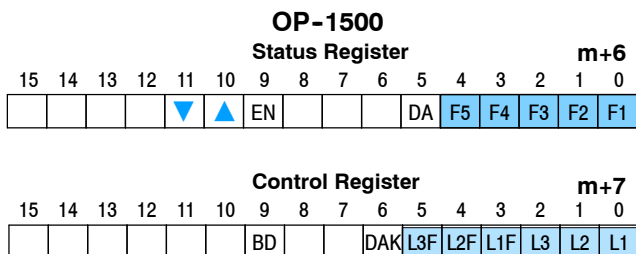



NOTE: In the following examples we assume that the OP-panel is configured with a base register of **Direct**LOGIC address V2000. In this case, Status register m+6 is V2006 which we will assume has been mapped to V40600, the **Direct**Logic internal Control Relay memory. Mapping details are discussed later in this chapters.

Pushbutton Example

The pushbutton example shown here is using **Direct**LOGIC PLC address references. The equivalent instructions for *other* PLC products supported are demonstrated in the "Application Examples" located in Appendices B-D of this manual.

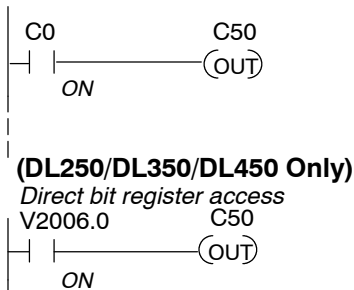

In this example, C0 represents the pushbutton No.1 (F1) via the mapping process. When push-button No.1 is pressed C0 is true and Coil C50 is energized.

* Status Register (m+6) = V40600: C0 - C17

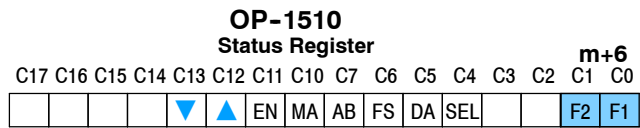
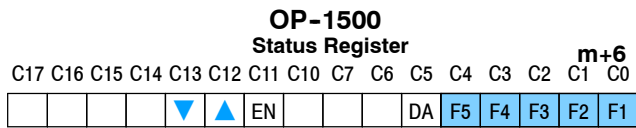
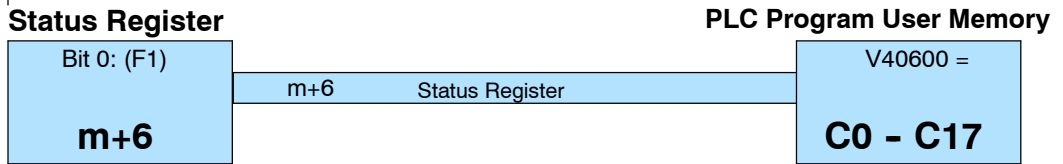

Pushbuttons Using Direct Access to Status Register bits

The **Direct**Logic DL250/DL350/DL450 CPUs and the Allen-Bradley SLC 5/03 and 5/04 support instructions which provide individual status bits access. This is called **Bit-of-Word** capability. For example, in the figure above, the ladder logic for the DL250/DL350/DL450 monitors the first bit of the Status word directly. Once again, our example assumes that we configured the OP-panel with a starting base address of V2000. If you were using an OP-1510, only bits 0 and 1 would be available for user-defined pushbuttons, since it only has two user-defined pushbuttons.

Pushbutton LEDs

There are LEDs located on each of the user defined pushbuttons. These LEDs indicate the pushbutton status condition is ON or OFF. You may choose the pushbutton type while configuring your OP-panel(s). There are two different operator controls, alternate or momentary, which will determine the LED response when the pushbuttons are pressed. In the case of an alternating configured pushbutton, the LED will toggle ON and OFF each time the pushbutton is pressed. With momentary configured pushbuttons the LED is ON only as long as the pushbutton is being pressed. The concept of momentary and alternating are used according to each PLC application.

Lamp Example

The lamp examples shown here are using **Direct**LOGIC PLC address references. The equivalent instructions for *other* PLC products supported are demonstrated in the "Application Examples" located in Appendices B-D of this manual.

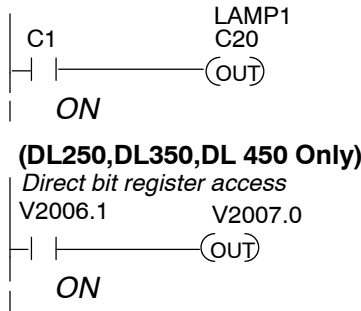

In this example, C1 represents the pushbutton No.2 (F2) via the mapping process. When *alternating* pushbutton No.2 is pressed internal Control Relay C20 is true and via mapping process Control register Bit 0 (L1 Green Lamp) is energized.

* Control Register (m+7) = V40601: C20 - C37

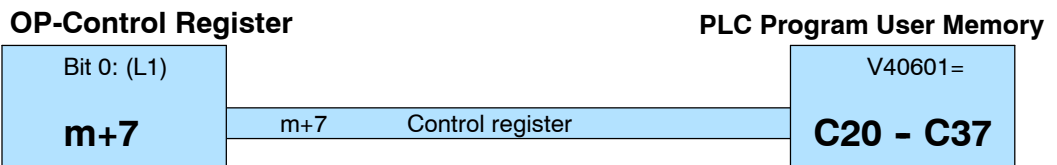

All lamps may be controlled using the concept shown above. You may use the Lamp Flash option by controlling the appropriate Flash bit via the ladder logic program. The example figure below demonstrates how to use the Control register Flash bits (L1F, L2F, and L3F).

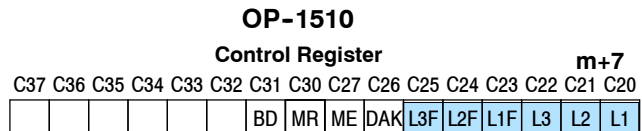
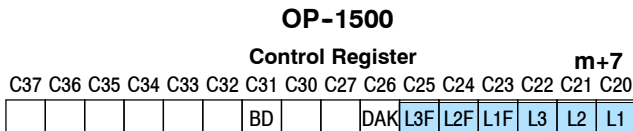

Lamp Flash

The lamp flash examples shown here are using **Direct**LOGIC PLC address references. The equivalent instructions for *other* PLC products supported are demonstrated in the "Application Examples" appendices located in this manual.

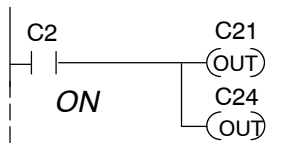

In this example, C2 represents the pushbutton No.3 (F3) via the mapping process. When *alternating* pushbutton No.3 is pressed internal Control Relay C21 and C24 are energized ON. This process manipulates Control register bit 1 and bit 4 which controls yellow lamp and flashing.

* Control Register (m+7) = V40601: C20-C37

(DL250/DL350/DL450 Only)

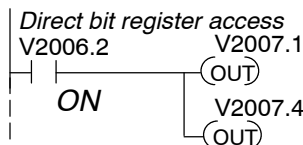

Memory Mapping Process

Each OP-1500 or OP-1510 are assigned 128 bits of PLC user memory which will be used as the OP-panel(s) database. The ladder logic program must access this assigned OP-panel memory. Let's take a closer look at this user memory and how it relates to the OP-panel features.

OP Base Register Memory Definition

Regardless of which PLC product you are using, the base registers address m+0 through m+7 are formatted the same. In this manual, when the terms m+0 through m+7 are used, this identifies which base register(s) are effected for the topic being covered. Study the figure below to begin understanding the register layout for both OP-panels.

Base Address	Manual Reference	Function Description
m+0	=	Top line message selection
m+1	=	Bottom line message selection
m+2	=	Top line data / menu function (OP-1510)
m+3	=	Decimal point, top line
m+4	=	Bottom line data
m+5	=	Decimal point, bottom line
m+6	=	Status register
m+7	=	Control register

Operator Panel Base Memory

PLC user memory is assigned to each panel with the OPEditor configuration software. For new OP-panels and add-on applications the programmer must define eight 16 bit registers for PLC interface. Below is a figure showing memory layout for **Direct**LOGIC DL105,DL205,DL405 PLC's and uses V2000-V2007 for OP-panel No.1 and V2010-V2017 for OP-panel No.2. See the next page for other PLC product memory usage examples.

You must reserve 128 bits (eight 16-bit registers or sixteen 8-bit registers) which are used to process data between the Operator panel and your PLC. You must configure the **Base** register for each OP-panel using the OPEditor configuration software. This base register address is stored in the OP-panel program.

If more than one OP-panel is connected to a single CPU, you must assign a **separate** memory area for **each** OP-panel. The Base addresses assigned to each panel must not overlap. You may connect up to 31 Operator panels to a OP-9001 Communications Master, which is referred to as a multi-panel application. You must choose unused memory registers for each OP-panel within your PLC application to ensure proper data communication.

- V2000
- V2001
- V2002
- V2003
- V2004
- V2005
- V2006
- V2006

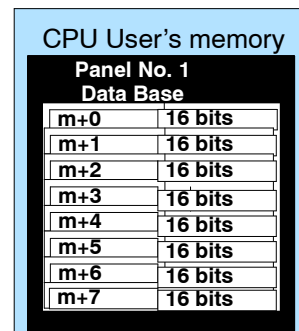

Total: 128 bits each

- V2010
- V2011
- V2012
- V2013
- V2014
- V2015
- V2016
- V2017

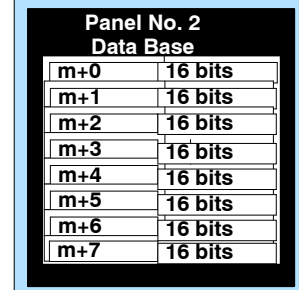

OP-Panel User Memory

Let's examine the different address conventions for PLC *Direct* and Allen-Bradley. For example, the PLC *Direct* address references are **octal**, and the Allen-Bradley is **decimal**. The *Direct*LOGIC DL105/L205/DL350/DL405 OP-panel address uses V-memory registers which are 16-bit registers. The DL305 family uses reference assignments with 8-bit registers. This means that the DL305 will require sixteen 8 bit registers for data handling. The Allen-Bradley memory is defined with a reference which (**Nx**) represents the memory area, and (**:n**) which defines the word within the memory area. Please refer to the appropriate CPU User manual for the PLC product you are using within your automation system.

*Direct*LOGIC DL105/DL205/DL350/DL405

Example Address		Function
V2000	m+0	Top line message selection
V2001	m+1	Bottom line message selection
V2002	m+2	Top line data/menu function
V2003	m+3	Decimal point, top line
V2004	m+4	Bottom line data
V2005	m+5	Decimal point, bottom line
V2006	m+6	Status register
V2007	m+7	Control register

*Direct*LOGIC DL305 (DL330/DL340 only)

Example Address		Function
R400/R401	m+0	Top line message selection
R402/R403	m+1	Bottom line message selection
R404/R405	m+2	Top line data/menu function
R406/R407	m+3	Decimal point, top line
R410/R411	m+4	Bottom line data
R412/R413	m+5	Decimal point, bottom line
R414/R415	m+6	Status register
R416/R417	m+7	Control register

Allen-Bradley SLC 500

Example Address		Function
N7:0	m+0	Top line message selection
N7:1	m+1	Bottom line message selection
N7:2	m+2	Top line data/menu function
N7:3	m+3	Decimal point, top line
N7:4	m+4	Bottom line data
N7:5	m+5	Decimal point, bottom line
N7:6	m+6	Status register
N7:7	m+7	Control register

DirectLOGIC User Memory Overview

Features

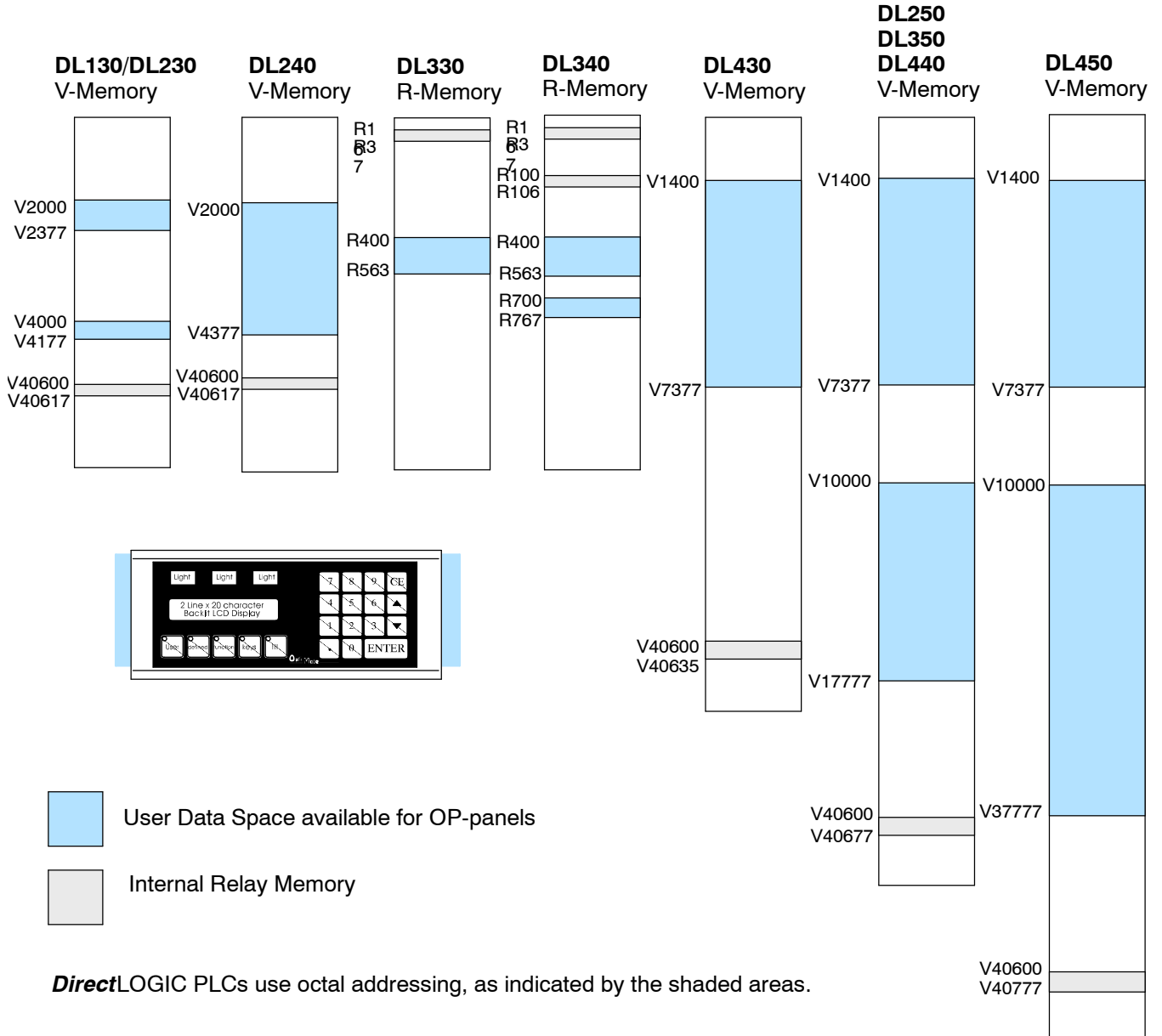

NOTE: The OPEditor shows a maximum of V41777 for possible base register addresses. This higher number was placed there to account for future product plans. Currently, the highest V-memory address available for mapping is V40777. Keep in mind that you must choose an available *base register address* that allows the proper number of bits upward to map the entire configuration. The OP-1500 and OP-1510 each require 128 bits to be mapped.

Mapping Operation

We explained in previous sections the PLC and OP-panel must exchange data on a *bit-level* basis. For **DirectLOGIC** controllers, the OP-panel **Status register** (m+6) and **Control register** (m+7) must be mapped into internal control relays such as C0,C1, etc. This allows *direct access* to the Status and Control bit registers. You must execute mapping every CPU scan in order to update data between the OP-panel and PLC.

The following examples assume the OP-panel starting Base-Register (m+0) is assigned to word register V2000. For example, the DL105, DL205, DL350, and DL405 CPUs have internal control relays starting at register V40600. They are designated as C0, C1, etc. Mapping updates Status and Control data (m+6 and m+7) into appropriate base registers V2006 and V2007 each PLC scan.

Mapping Example (DL105, DL205, DL350, and DL405)

DL105, DL205, DL350, and DL405

This figure demonstrates how the OP-panel Status word is mapped to ladder program user memory for bit manipulation. In this figure, notice the sixteen bits in the STATUS register are loaded into the Internal Control Relays C0-C17. These control relays are used within the ladder logic program for monitoring pushbuttons and coordinating data entry control.

SP1 (always ON) maps OP register V2006 to V40600:C0 -C17.

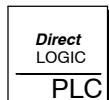
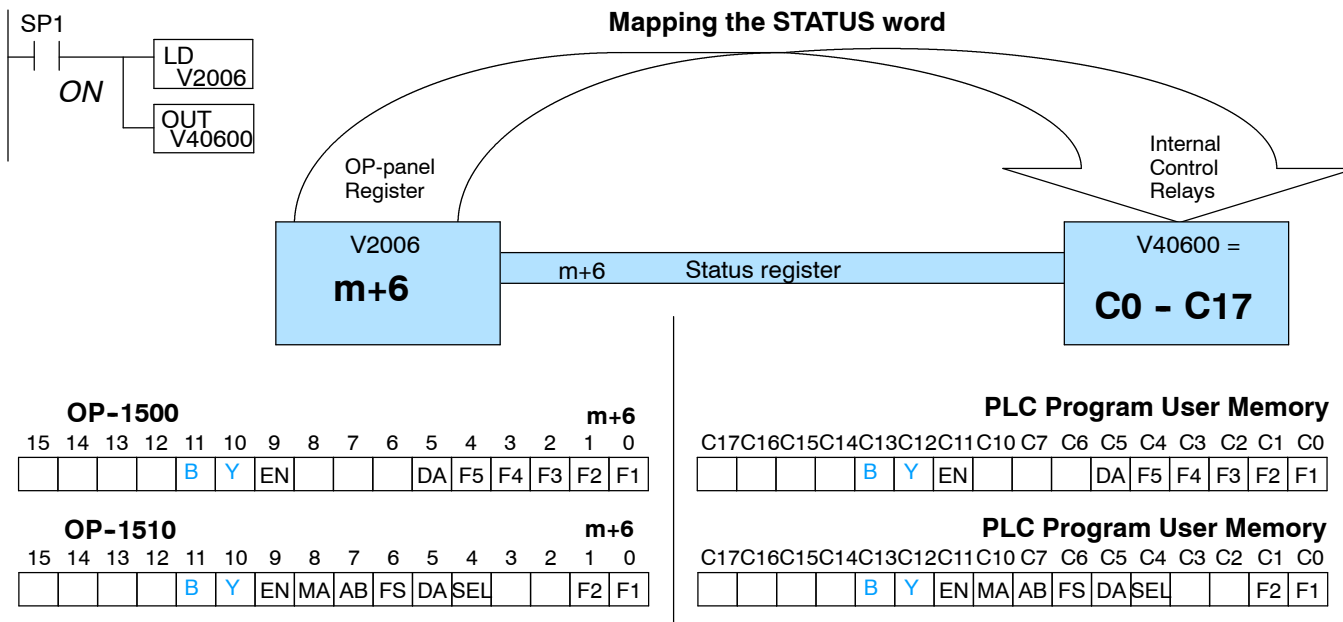

DirectLOGIC PLCs : Status and Control Registers (m+6, m+7) are required to be mapped to Internal Control Relay memory. For example, the register V40600 = C0-C17 (m+6) Status, and V40601 = C20-C37 (m+7) the Control register.

the Features

DL105, DL205, DL350, and DL405

This figure demonstrates how the internal control relay memory, for bit manipulation, is mapped into the OP-panel Control word. In this figure, notice Control Relays C20 through C37 are loaded into the OP-panel CONTROL register address m+7. The control word operates the annunciator lamps, flashing control and menu/data entry operations.

SP1 (always ON) maps data bits V40601:C20 -C37 to OP-panel Base register V2007.

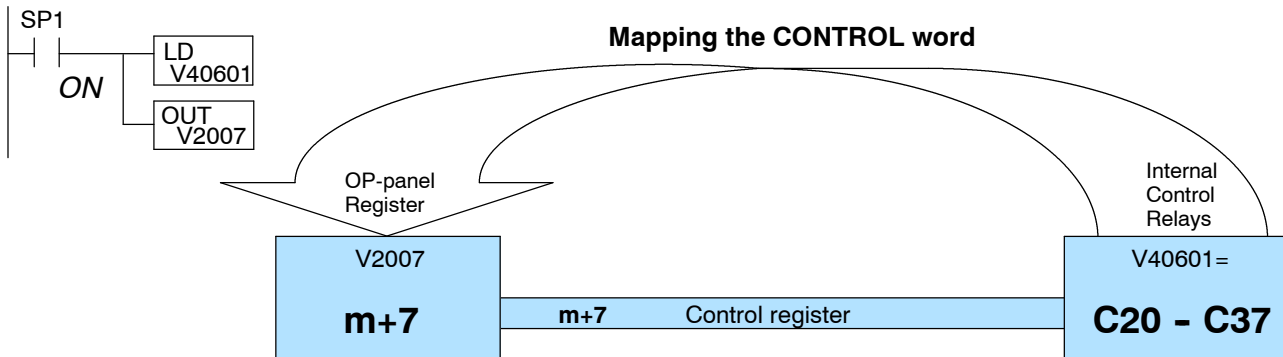

Features

OP-1500 m+7

15	14	13	12	11	10	9	8	7	6	5	4	3	2	1	0
						BD			DAK	L3F	L2F	L1F	L3	L2	L1

OP-1510 m+7

15	14	13	12	11	10	9	8	7	6	5	4	3	2	1	0
						BD	MR	ME	DAK	L3F	L2F	L1F	L3	L2	L1

PLC Program User Memory

C37	C36	C35	C34	C33	C32	C31	C30	C27	C26	C25	C24	C23	C22	C21	C20		
								BD	MR	ME	DAK	L3F	L2F	L1F	L3	L2	L1

PLC Program User Memory

C37	C36	C35	C34	C33	C32	C31	C30	C27	C26	C25	C24	C23	C22	C21	C20		
								BD	MR	ME	DAK	L3F	L2F	L1F	L3	L2	L1

Mapping Example (DL330/DL340)

DL305 Family

Let's look at mapping the DL330/DL340 PLC belonging to the DL305 family. Unlike the DL105, DL205, DL350, and DL405 mapping examples described on the previous pages, the DL305 uses 8-bit words. It therefore takes two words for each mapped memory location, because each mapped memory location needs sixteen consecutive bits, on one data word. We will assume that R400 was used as the base register address and we want the mapping to start at R16 for the **Status register** and R20 for the **Control register**.

DL305 Only

This figure demonstrates how the OP-panel Status word is mapped to ladder program user memory for bit manipulation. In this figure, notice the two 8-bit STATUS registers (m+6) are loaded into the Internal Control Relays R16 - R17. These control relays are used within the ladder logic program for monitoring pushbuttons, and coordinating data entry control.

Not C374 (always ON after first scan) maps OP register R414/R415 to R16/R17.

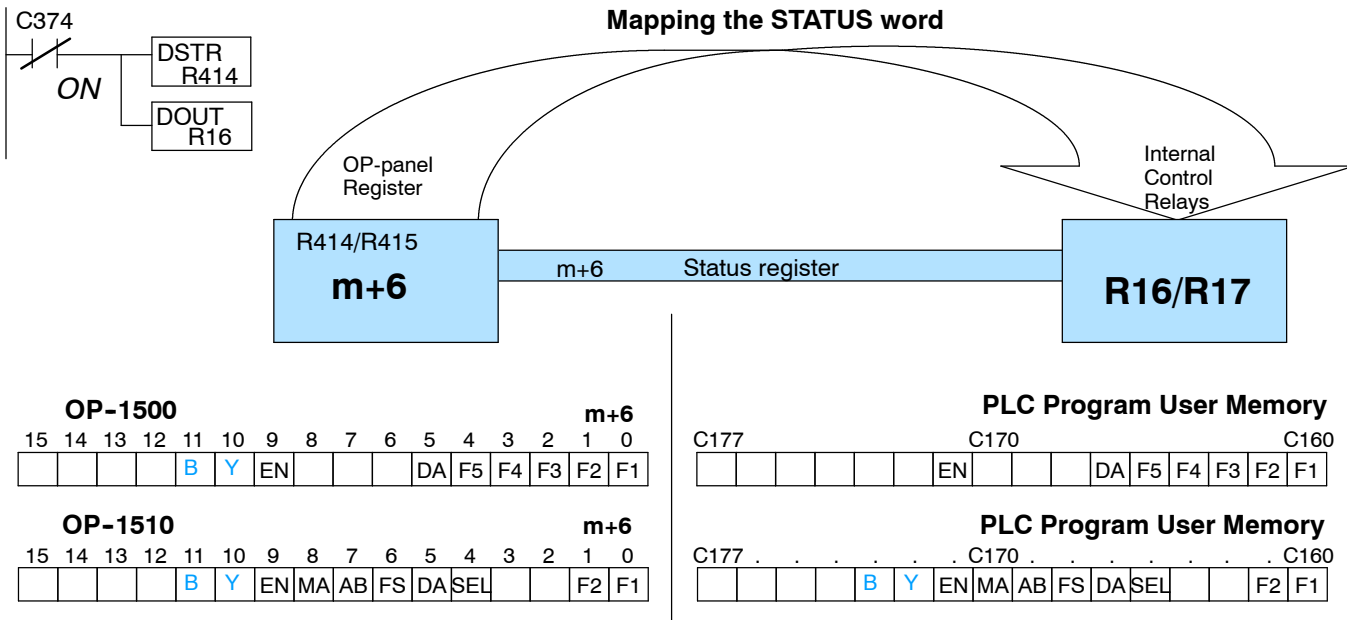

Configuring Your Operator Panel

In This Chapter. . . .

- Preparing for Configuration
- How to Configure Your Panel

Preparing for Configuration

Configuration

If you prepare and plan all information ahead of time, your use of the OP-WINEDIT configuration software will be very successful. Below are a few important items to perform while programming your application.

- Prepare personal computer and ensure proper installation of the OP-WINEDIT configuration software.
- Examine and understand your operator interface requirements. Determine which OP-panel(s) are needed, and if a single panel or multiple panel configuration is to be used.
- Know your PLC product and available resources, such as programming tools, CPU capabilities, unused or user memory for base register assignment (128 consecutive bits/panel)
- Verify type of communications port, as well as which protocol will be used. Determine the CPU link(s) available for connecting an OP-panel (RS-232/RS-422, baud rate, parity, stop bit).
- Think about how the Lamps, Pushbuttons, LEDs, and messages will be assigned in your Operator panel(s) with respect to your machine or process.

To prepare your application, use the Application Worksheets which are provided in the Appendix A of this manual. The example worksheets will help you understand how the OP-1510 Kiln Demo program is configured. The blank worksheets can be used in planning, implementing, and using your OP-1500 and/or OP-1510 units.

OPEditor Software

The OP-1500 and OP-1510 are configured with software running on a personal computer. This software is available through **PLC*Direct***, and referred to as the OPEditor configuration software (part number OP-WINEDIT). The OPEditor is used to download your configuration before connecting the OP-1500 or OP-1510 unit(s) and communicating to a PLC or OP-9001 Communication Master.

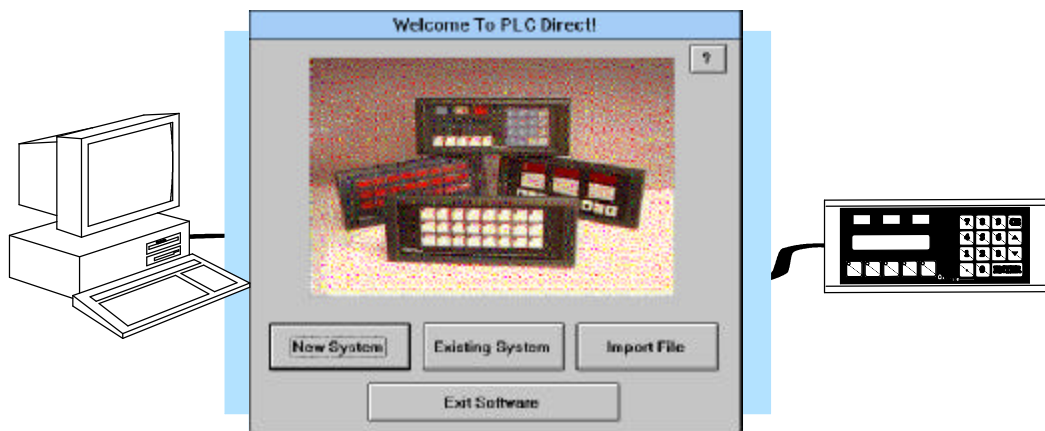

**More about
the OPEditor**

The OPEditor configuration software allows you to configure OP-panel applications, as well as download (write to panel) and upload (read from panel) the configurations. Use this software to configure your communication link(s), select pushbutton control, and enter operator display messages. The newer and most recommended software is the **OP-WINEDIT** package. This windows software may be ordered from PLC*Direct* using part number OP-WINEDIT.

**OPEditor
Documentation**

For the OP-WINEDIT software (e.g. version 1.01 or greater) configuration **Help windows** are provided for performing all necessary configuration tasks. Should you have problems understanding how to program your panel, refer to these built-in On Line Help windows. To call the Help windows, point and click on the Help menu and choose Using help, or click on the [?] ICON located near the top of the main configuration window.

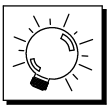

TIP: You may design and configure your Operator Panel configuration(s) offline and save them to disk. The programs may then be downloaded to the OP-panel(s). Appendix A "Application Worksheet" should be used to help plan your configurations and programming process for each panel.

**System
Requirements**

The OP-WINEDIT software, must have the following minimum PC configuration:

- IBM 386 (or better) compatible computer
- VGA or SVGA video board and color monitor
- 1 meg of free hard drive space
- 1 meg of RAM memory
- Windows 3.1 or higher (OP-WINEDIT)

How to Configure Your Panel

To prepare an OP-panel for operator use, the following steps are required. These steps should be followed for implementing either the OptiMate OP-1500 and/or OP-1510 panels.

Step 1 Load OPEditor - If you are not already using the configuration software, you must install the OP-WINEDIT configuration software. The software is provided on one 3-1/2" high density diskette and includes an installation guide. The following is a description on how to install OP-WINEDIT.

- Place the installation disk into your computer's floppy drive (usually either drive A or drive B).
- Open Microsoft Windows (3.0 or above) and select **File/Run** from the Program Manager (upper-left corner).
- Select **Run**, and you will see a pop-up window. Type in the path for the drive in which you have placed the setup disk and designate the file **setup**. Here we have used drive A. Click on **OK** when you are finished.

Personal Computer Minimum Requirements:

- ✓ IBM type 386 or above
- ✓ 1 meg of hard drive
- ✓ **Windows 3.1 or later**
- ✓ **Windows 95**
- ✓ 1 meg of RAM

Disk Media:

- ✓ One 3-1/2" high density

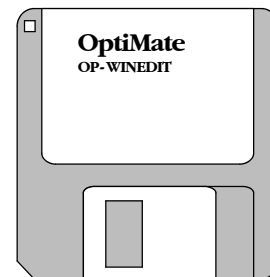

Step 2 Select the COM ports - Your OP-WINEDIT software requires you select which port is to be used for upload and downloading. Ensure serial port selected is not being used by other PC software while attempting to operate the OP-WINEDIT software.

Step 3 Choose Single or Multiple Panel - Decide the number of operator panels to be used within your application.

Step 4 Select the Configuration Link - Here is where you will need to select the PLC type and model which will be used in your OP-panel application.

DirectLOGIC PLCs : Some **DirectLOGIC** CPUs feature a secondary communication port which may be used to connect the OptiMate units. Your OPEditor configuration must match the PLC port setups, such as address, baud rate, stop bits, and parity. Also ensure the secondary communications port is set for HEX mode, not ASCII.

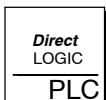

Step 5 Complete the Communications Information - After you have selected the PLC type you must define the remaining protocol items, such as the baud rate, parity and stop bit settings. The following table provides the necessary information for most **PLCDirect** controllers. In the case of using other PLC product and family, you should reference the proper product User manual(s) to determine the port communications capabilities.

PLC Model	Port/Baud Rates	Parity	Stop Bit
DL105/230/240	Top	9600	Odd
	Bottom	Bottom (DL240 only) 9600/19.2k	Odd/None
DL250	Top	9600	Odd/None
	Bottom	9600/19.2K	
DL330	DCU only	4800/9600/19.2k	Odd/None
DL340	Bottom & Top	4800/9600/19.2k	Odd/None
DL350	Top	9600	Odd
	Bottom	4800/9600/19.2K	Odd/None
DL430/440	Top	Top 9600	Odd
	Bottom	9600/19.2k	Odd/None
DL450	DB15	9600	Odd
	DB25	9600/19.2k	Odd/None
	RJ12	9600/19.2k	Odd/None

During configuration, ensure that your address and communications parameters match the PLC port settings. There will be a selection for PLC timeout. When the panel sends a message to the PLC and does not receive a response or does not understand the response, it will wait the time-out period before resending the message. A communication failure after 12 seconds initiates the message "Host Communication Fail" on the panel.

You also have several ports which can be used to connect your communications cable. Some of these ports have fixed PLC address assignments, and some *do not*. The ports which allow configuring the PLC addresses can be set to a unique address, ranging from 1 through 90. **Refer to your User Manual for specific information on the ports of your PLC.**

OTHER
PLC

OTHER PLCs: For Allen-Bradley, you will need to connect to Channel 0 (bottom serial port), using DF1 full duplex. Additionally, the Allen-Bradley software allows you to set the bottom port to a unique PLC address. The software default is PLC Address 1. You must select CRC error detection and ensure the address on the configuration screen matches the address you have assigned. This port must also be configured for either 4800 or 9600 baud. No other baud rates are supported for communicating between the OP-panels and an Allen-Bradley PLC. Since the Allen-Bradley software uses a default baud rate of 1200, you must change the settings.

- Step 6 Select the Panel Address** – The panel has a DIP switch on the rear of the unit which is used to set the panel address (between 0-31). This address is used for two functions. The first function is for setting the address for configuration and the second is for the specific panel address. This panel address (0-31) is used with multiple panel configurations and the OP-9001 Communications Master. The address number that you select on the switch must also be configured to the panel.
- Step 7 Select the Base Register Address and File Number** – This step is very important because it establishes the link in your PLC memory to the panel. For **DirectLOGIC** PLCs Chapter 3 **Understanding the OP-1500 and OP-1510** describes the mapping process. Once you are familiar with the mapping process and you know the memory in your PLC to use (refer to the user manual for your respective PLC type), enter your selection.
- If you choose Allen-Bradley as your PLC Type, you must enter the PLC File Number in addition to a Base Register Address. You must expand the memory map in the Allen-Bradley PLC to include all registers being used by the OP-panel. The panel will only recognize integer file types N7 and user-defined file types N9 through N255. Enter the number only and not the prefix N. The Base Register Address is any number between 0 and 255.
- Step 8 Select the Panel Type** – Since the configuration program is the same for all panels, you will need to select OP-1500 or OP-1510 according to the panel type you are implementing.
- Step 9 Configure the Panel Functions** – Prepare the functions of the panel and how the operator control shall work for the features you are selecting to use. These features are discussed in detail in Chapter 3 **Understanding the Features**.
- **Pushbutton Configuration** – The pushbuttons can be configured as either Momentary or Maintained (alternate ON/OFF). Momentary pushbuttons remain ON as long as you are pressing them while Maintained pushbuttons retain their status (ON or OFF) until the next time they are pressed.
 - **Message** – The messages may be configured as Static, Dynamic or Interactive type. Please refer to Chapter 3 Understanding the Features to better understand these message types. You should enter all messages using the Message Configuration window.
 - **Menu and Sub-menu Configuration** – The OP-1510 has an additional ability to allow you to configure a menu sub-menu hierarchy for the purpose of displaying and interacting with screen messages. You may configure up to four levels of sub-menus for message hierarchy.

Step 10 (OP-1510 Only) Configuring your Menu - In order to successfully use the Menu and Sub-menu features refer to the "Menu and Sub-menu" section of Chapter 3 in this manual. The OP-WINEDIT configuration software allows definition of the following terms.

- Level Number - defines the menu/sub-menu for each item number and how it is represented (up to four levels of sub-menu nesting permitted).
- Function number - is assigned to menu messages in which interactive message type is required. The function numbers must be unique for each menu message and should follow sequential order. This allows for the function number to be evaluated within register m+2, when a menu item is selected.

While configuring a menu message system the menu items are assigned in sequential order 1 thru 160. Each item within the menu/sub-menu hierarchy require parameterizing in the following steps.

1. Select the existing or new OP-1510 panel configuration file.
2. Access the "Menu configuration" window or screen.
3. Begin entering the hierarchy at item 1 for the main menu/function.
4. Enter text message and menu control characteristics for each item, such as level number, function number, etc..
5. Menu structures may be entered with sub-menu messages. You may nest up to four levels of sub-menus.
6. For Functions, configure the function number within the message entry box. Function numbers should be entered in sequential order (1, 2, 3, etc..).

Your Menu Plan

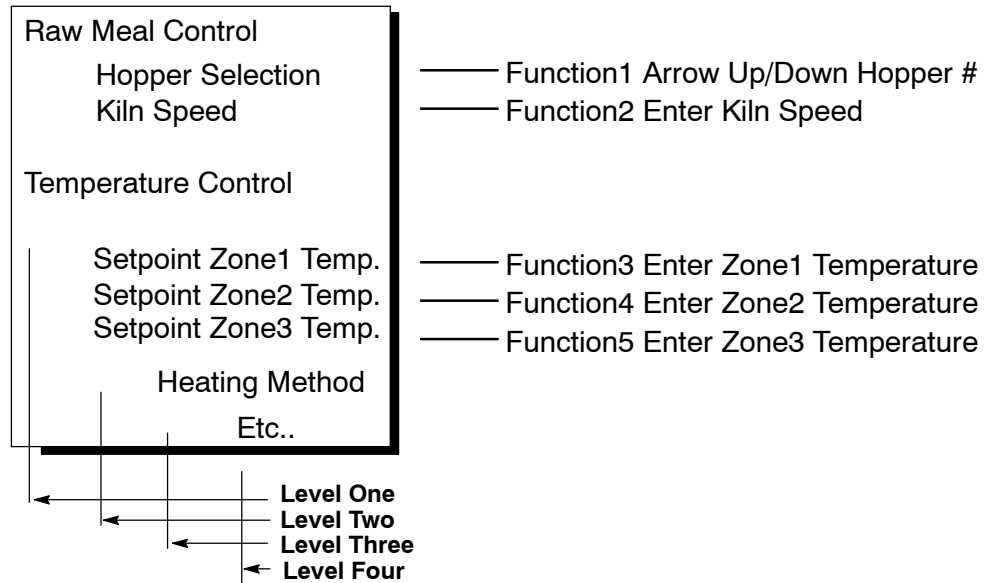

- Step 11 Save and Download** – Once you have completed your configuration, you can save it to disk and/or write directly to the panel. If saving to the panel, verify that the DIP switch is set to 31 (refer to Preparing the Panel for Configuration Chapter 2) to download the configuration. When downloading to OP-panels which have already been configured, you must first *clear the message list* before loading the new configuration. This will ensure the old messages which are configured *do not* remain within the OP-panel's memory.



NOTE: After your configuration has been properly downloaded, you will need to reset the DIP switch to the appropriate panel address and power cycle the panel. This can be accomplished by simply removing and reinstalling the power source.

Maintenance and Troubleshooting

In This Chapter. . . .

— Troubleshooting the OP-1500/OP-1510 panels

Troubleshooting the OP-1500/1510 Panels

Troubleshooting

In this section, we explain how to isolate potential problems, which may occur while using the OP-1500 and OP-1510. If you are unable to troubleshoot and correct your problems using this document, please contact our product support team. You can reach technical product support within the hours of 9:00 AM and 6:00 PM (EST) Monday through Friday. Call **1-800-633-0405** or fax **(770) 889-7876**.

We have organized the troubleshooting into three categories:

- Panel configuration problems
- Panel and PLC communications failures
- Panel Operation problems

Panel Configuration Problems

We explained in previous sections the OP-WINEDIT configuration software is used to create OP-panel applications, download, and upload your OP-panel programs. If you are online with the panel and communications fails, the following error message is displayed.

“Could not communicate with panel” (OP-WINEDIT)

1. Check the rear panel RX/TX LEDs while attempting the Upload or Download operation. If the LEDs (RX/TX) are slow alternating flash signals, the PC and OP are connected. If *only* the TX (transmitter) LED is flashing, or the TX/RX are *not* alternating between flashes, verify the OP-panel is set to address 31 (Configuration Mode).
2. Check and verify the configuration cable (**OP-ACBL-1**) is properly connected. For cable details, refer to Chapter 2, the Cable Specification section.
3. Ensure configuration mode is selected, by setting all *address* switches to the ON position (Address 31).
4. Ensure the correct communications port is selected with the software, such as COM1, COM2, COM3, COM4.
5. Check 24VDC power source.
6. Reattempt the online panel Download or Upload procedure.

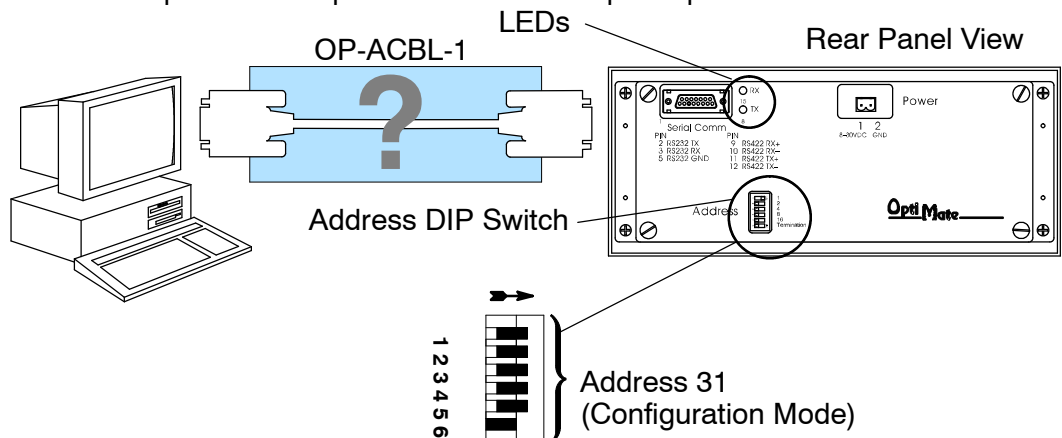

Panel to PLC Communications

If you experience communications difficulties between the OP-panel and PLC, you will get a "HOST COMM FAILURE" message flashing on the display screen. You may also notice the Pushbuttons, Lamps, and Operator messages are not working. In this case, you should check the following items:

1. Observe the TX and RX LEDs on the rear of the panel. If both LEDs are not a steady flash or glow (depending on baud rate) check and ensure the proper communications cable is securely connected.

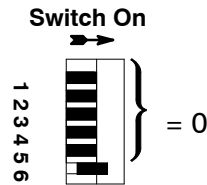
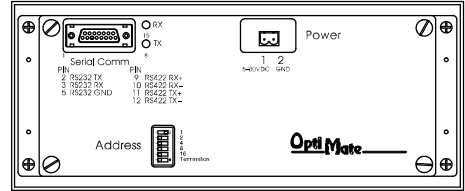

Switch	1	2	3	4	5	6
Address Value	1	2	4	8	16	T

Termination Resistor

Example Address

2. Examine Address switches to ensure correct address selection (valid settings 0 - 30). You must cycle OP-panel power for address switch changes to take effect.
3. Examine the communications information for the PLC type, protocol type, baud rate, parity, stop bit, address number. Use the respective user manuals for the PLC product you are using to determine the proper settings.
4. If you are using an OP cable, verify cable pinout. For RS422 connections use a Belden 9279 or equivalent cable.
5. Check 24VDC power source.



DirectLOGIC PLCs : If you are using the secondary communications port such as **DirectLOGIC** PLC port 2, ensure the communications port address and protocol setting match.

PLC Model	Port/Baud Rates	Parity	Stop Bit
DL105/230/240	Top	9600	Odd
	Bottom	Bottom (DL240 only) 9600/19.2k	Odd/None
DL250	Top	9600	Odd/None
	Bottom	9600/19.2K	1
DL330	DCU only	4800/9600/19.2k	Odd/None
DL340	Bottom & Top	4800/9600/19.2k	Odd/None
DL350	Top	9600	Odd
	Bottom	4800/9600/19.2K	1
DL430/440	Top	Top 9600	Odd
	Bottom	9600/19.2k	Odd/None
DL450	DB15	9600	Odd
	DB25	9600/19.2k	Odd/None
	RJ12	9600/19.2k	Odd/None

Allen-Bradley Panel to PLC Communications

For Allen-Bradley, you may connect to Channel 0 (bottom serial port), using DF1 in full duplex mode. Additionally, the Allen-Bradley software allows the bottom port to a unique PLC address. The Allen-Bradley software default is PLC address one. You must ensure the OP-panel configuration address matches the PLC address you have assigned. The Allen-Bradley port only communicates using either 4800 or 9600 baud. No other baud rates are supported between the OP-panel and Allen-Bradley PLC. For example, on Allen-Bradley PLC's the serial port baud rate defaults to 1200 baud and must be changed. The baud rate for channel 0 must be set to 4800 or 9600 baud to match the OP-WINEDIT configuration. Also the base memory area must be expanded to include the full range of registers such as N7:0 through N7:7.



OTHER PLCs : Regardless of which PLC brand you are implementing, the communications parameters should be reviewed and properly configured. Please check the appropriate manual for your PLC product to ensure proper communications port and panel type settings.

Appendix A

Worksheets

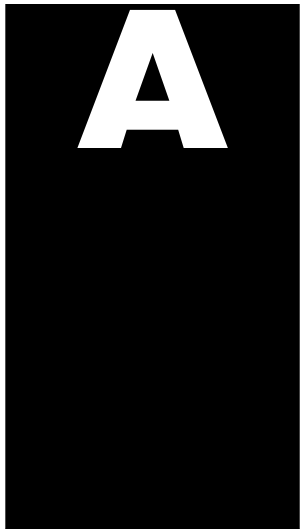

In This Appendix. . . .

- *Example* Application Worksheet
 - *Example* Message Worksheet
 - *Example* Menu Worksheet
 - User's Application Worksheet
 - User's Message Worksheet
 - User's Menu Worksheet
-

KILN DEMO EXAMPLE WORKSHEET

PAGE: _____

DESCRIPTION : OP-1510 Kiln Demo
 System Type Single Panel
 Panel Type OP-1510
 PLC Base Register Addr V2000

PUSHBUTTONS / LAMPS :

A M (Alternate/Momentary)

F1 Start

F2 Stop

F3 _____

F4 _____

F5 _____

} **OP-1500 Only**

PLC CONFIGURATION :

PLC Family PLC Direct by Koyo
 CPU Model DirectLOGIC DL130
 Protocol K Sequence
 PLC Address 1
 PLC Timeout 3
 Baud Rate 9600
 Parity ODD
 Data/Stop Bits 8 data / 1 stop

Green Lamp1 System Running

Yellow Lamp2 System Starting

Red Lamp3 System Stopped

MESSAGE:

Text

No. 1	O	P	-	1	5	1	0		K	I	L	N		D	E	M	O			
	Action: N/A Data Type/Format: N/A Range: N/A																			
	Text Message																			
No. 2	M	E	N	U	:	S	E	T	U	P		F	1	:	S	T	A	R	T	
	Action: N/A Data Type/Format: N/A Range: N/A																			
	Text Message																			
No. 3	K	I	L	N		S	T	A	R	T	I	N	G							
	Action: N/A Data Type/Format: N/A Range: N/A																			
	Text Message																			
No. 4	P	R	E	S	S		F	2		T	O		S	T	O	P				
	Action: N/A Data Type/Format: N/A Range: N/A																			
	Text Message																			
No. 5	S	Y	S	T	E	M		R	U	N	N	I	N	G						
	Action: N/A Data Type/Format: N/A Range: N/A																			
	Text Message																			
No. 6	P	R	E	S	S		F	2		T	O		S	T	O	P				
	Action: N/A Data Type/Format: N/A Range: N/A																			
	Text Message																			
No. 7	K	I	L	N		S	Y	S	T	E	M		S	T	O	P	P	E	D	
	Action: N/A Data Type/Format: N/A Range: N/A																			
	Text Message																			
No. 8	P	R	E	S	S		F	2		T	O		C	O	N	T	I	N	U	E
	Action: N/A Data Type/Format: N/A Range: N/A																			
	Text Message																			
No. 9	M	E	A	L		H	O	P	P	E	R		(1	-	3)	:		^
	Action: N/A Data Type/Format: INTEGER/BCD Range:																			
	Text Message																			
No. 10	A	R	R	O	W		U	P	/	D	O	W	N		=	^	^	^		
	Action: Arrow Data Type/Format: BCD Range: 1-3																			

EXAMPLE MESSAGE WORKSHEET

PAGE: _____

MESSAGE:

	Text Message																				
No. 11	K	I	L	N		S	P	E	E	D		(%)	:	^	^	^	^		
	Action: N/A Data Type/Format: BCD Range: N/A																				
No. 12	N	E	W		K	I	L	N		S	P	E	E	D	=						
	Action: Keypad Data Type/Format: BCD Range: N/A																				
No. 13	Z	O	N	E	1		T	E	M	P		S	P	:	^	^	^	^			
	Action: N/A Data Type/Format: BCD Range: N/A																				
No. 14	E	N	T	E	R		N	E	W		T	E	M	P	.	=	^	^	^	^	
	Action: Keypad Data Type/Format: BCD Range: N/A																				
No. 15	Z	O	N	E	2		T	E	M	P		S	P	:	^	^	^	^			
	Action: N/A Data Type/Format: BCD Range: N/A																				
No. 16	E	N	T	E	R		N	E	W		T	E	M	P	.	=	^	^	^	^	
	Action: Keypad Data Type/Format: BCD Range: N/A																				
No. 17	Z	O	N	E	3		T	E	M	P		S	P	:	^	^	^	^			
	Action: N/A Data Type/Format: BCD Range: N/A																				
No. 18	E	N	T	E	R		N	E	W		T	E	M	P	.	=	^	^	^	^	
	Action: Keypad Data Type/Format: BCD Range: N/A																				
No.																					
	Action: Data Type/Format: Range:																				
No.																					
	Action: Data Type/Format: Range:																				
No.																					
	Action: Data Type/Format: Range:																				
No.																					
	Action: Data Type/Format: Range:																				
No.																					
	Action: Data Type/Format: Range:																				
No.																					
	Action: Data Type/Format: Range:																				
No.																					
	Action: Data Type/Format: Range:																				

EXAMPLE MENU WORKSHEET

PAGE: _____

MENU:

Text

No. 1	R	A	W		M	E	A	L		C	O	N	T	R	O	L				
Level	1	2	3	4	Function No.				-											
No. 2	H	O	P	P	E	R		S	E	L	E	C	T	I	O	N				
Level	1	2	3	4	Function No.				1											
No. 3	K	I	L	N		S	P	E	E	D		C	O	N	T	R	O	L		
Level	1	2	3	4	Function No.				2											
No. 4	T	E	M	P	E	R	A	T	U	R	E		C	O	N	T	R	O	L	
Level	1	2	3	4	Function No.															
No. 5	S	E	T	P	O	I	N	T		Z	O	N	E	1		T	E	M	P	.
Level	1	2	3	4	Function No.				3											
No. 6	S	E	T	P	O	I	N	T		Z	O	N	E	2		T	E	M	P	.
Level	1	2	3	4	Function No.				4											
No. 7	S	E	T	P	O	I	N	T		Z	O	N	E	3		T	E	M	P	.
Level	1	2	3	4	Function No.				5											
No.																				
Level	1	2	3	4	Function No.															
No.																				
Level	1	2	3	4	Function No.															
No.																				
Level	1	2	3	4	Function No.															
No.																				
Level	1	2	3	4	Function No.															
No.																				
Level	1	2	3	4	Function No.															
No.																				
Level	1	2	3	4	Function No.															

B

Appendix B

DL105/DL205/DL350/DL405

Application Examples

In This Appendix. . . .
— DL105/DL205/DL350/DL405 Application Example

Understanding the Example Programs

In this manual a Cement Kiln System is the model for demonstrating the ladder logic required to support the various OP-panel features. The programs provide ladder logic which demonstrates controlling pushbuttons, lamps, messages and menu operations.

Items listed in the figure below such as Hopper Selection, Kiln Speed, Start/Stop/Run controls, and Kiln Zone Temperatures are monitored and controlled by the OP-panel example programs.

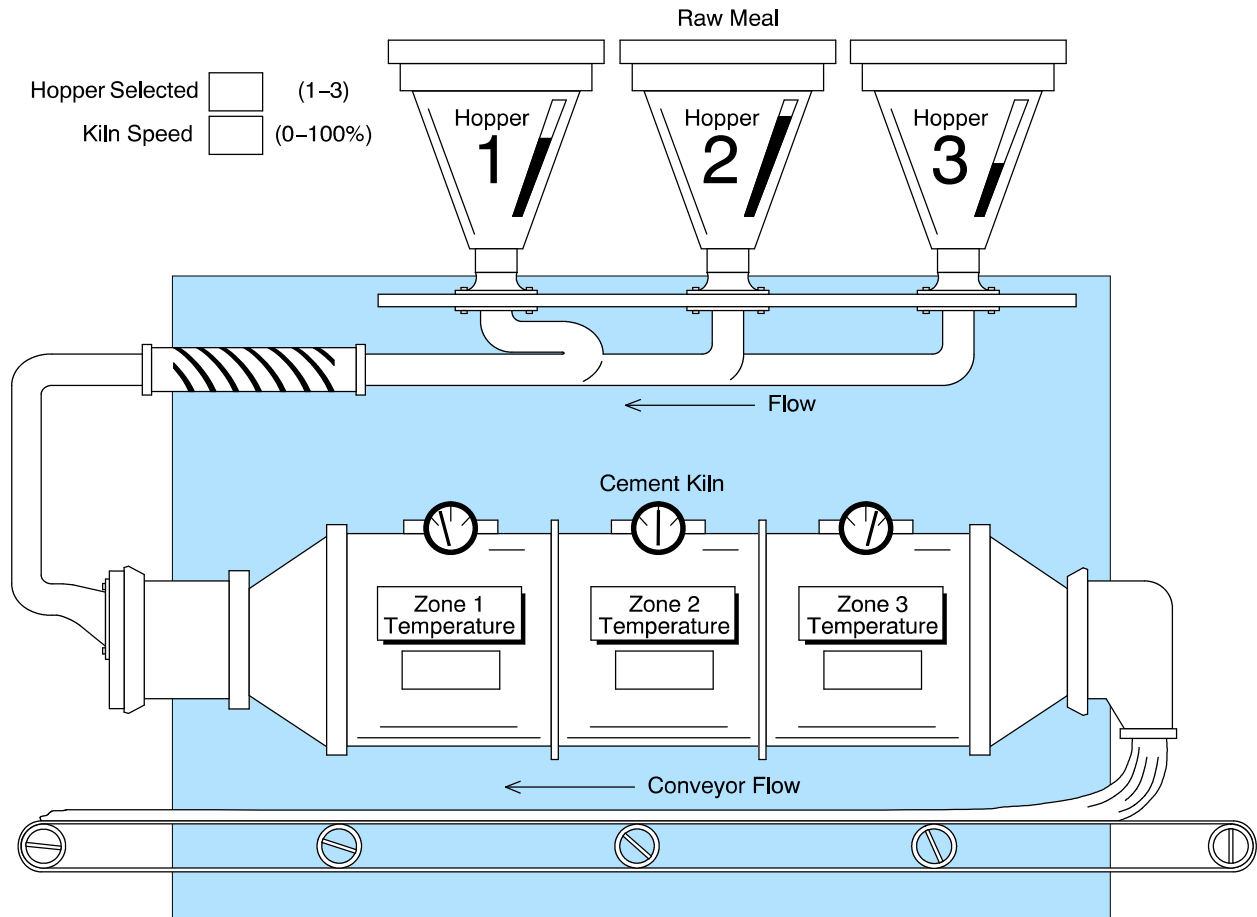

These example programs and additional technical support information may be accessed on **PLCDirect**'s **worldwide web** site:

<http://www.plcdirect.com> (website for general info/file transfers)

You may also find these programs on our 24-hour per day **BBS** system at:

770-844-4209

If you find a problem with any of our products, services, or manuals, please fill out and return the 'Suggestions' card that was shipped with this manual.

DirectLOGIC and Compatible Example Program

The example program listed on the following pages is designed for **DirectLOGIC** DL105, DL205, DL350, and DL405 PLC systems. The program supports the OP-1510 Kiln Demo program. This program is included on the 3 1/2 disk labeled "OP-1500/OP-1510 Example Disk" which is provided with this manual.

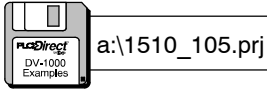

This example program (1510_105.PRJ) must be used with the OP-1510 configuration file 1510_105.OCF. Load these program files to the PLC and OP-panel for connection and operation of the Kiln Demo application. You may also refer to the Appendix A "Example Worksheets" to help understand how the OP-panel is configured.

OP-1510 Kiln Demo

This program is designed to be used with the **DirectLogic** DL105, DL205, DL350, and DL405 PLC and compatible systems. The following program is intended for training purposes and *may not* resolve all possible OP-panel applications. Some PLC programming knowledge is required to fully understand and implement the following program examples.

If the CPU power cycles or machine and operator conditions are idle, this rung will initialize OP-panel and display message #1 and message #2.

RUNG 1

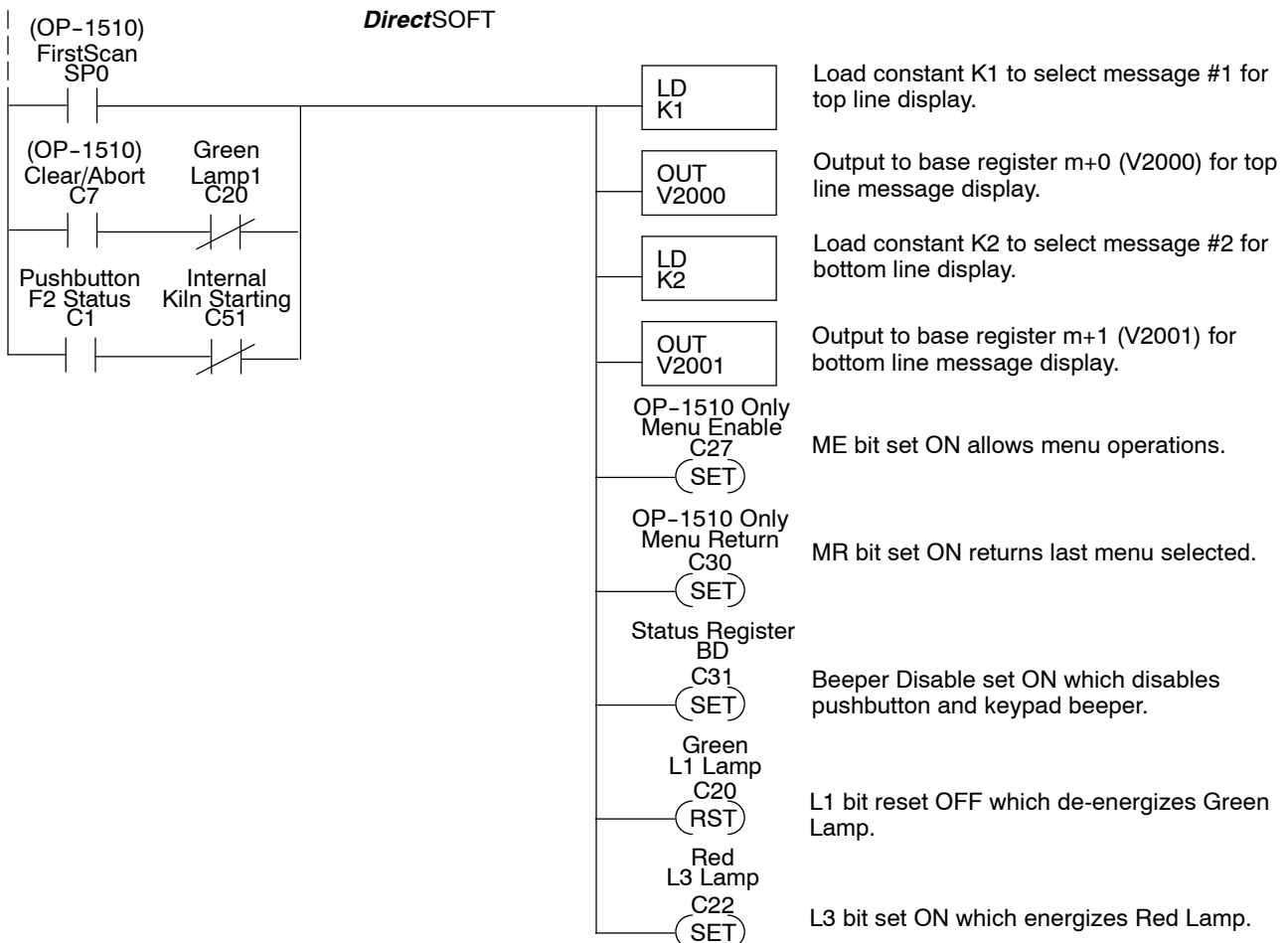

RUNG 2

Memory Mapping

This rung is necessary for all *Direct*LOGIC CPUs which *do not* support bit-of-word instructions. Mapping the Status and Control registers into Internal Control Relays is necessary to have bit level access to this data. The Status and Control register bits are used to monitor pushbuttons, control lamps, and perform asynchronous data exchange between the OP-panel and PLC.

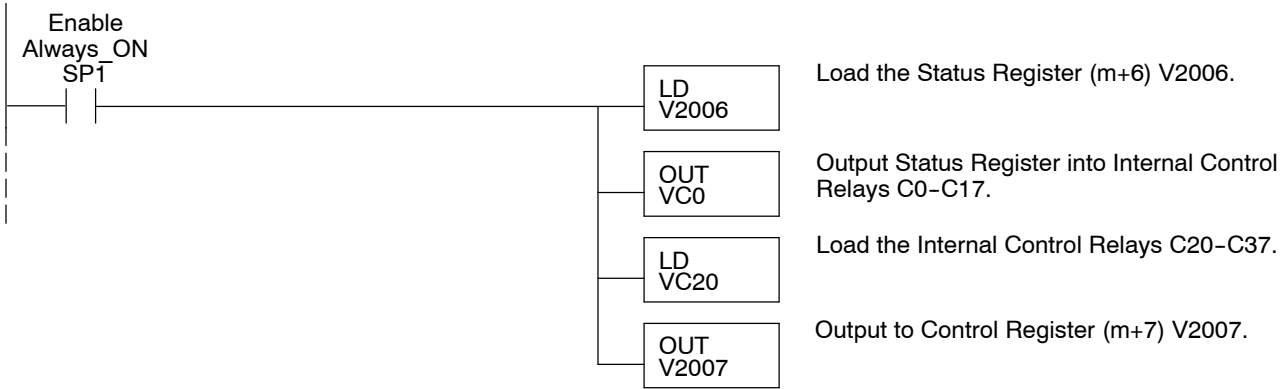

RUNG 3

Kiln Start Control

This rung starts the machine process. The internal control relay Kiln Start (C51) is used to start the Startup Delay Timer, and will remain ON until the C20 (Lamp1) control bit is energized.

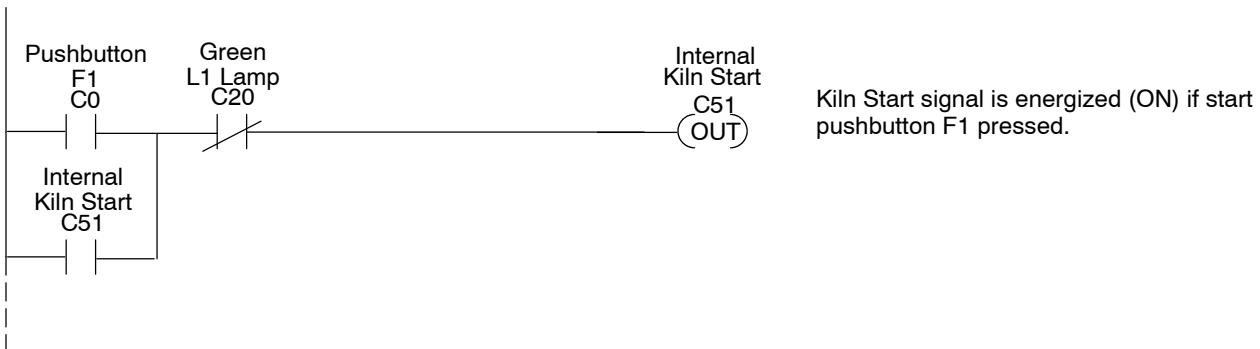

RUNG 4

Kiln Starting Lamp Control

This rung controls the annunciator lamps during startup mode.

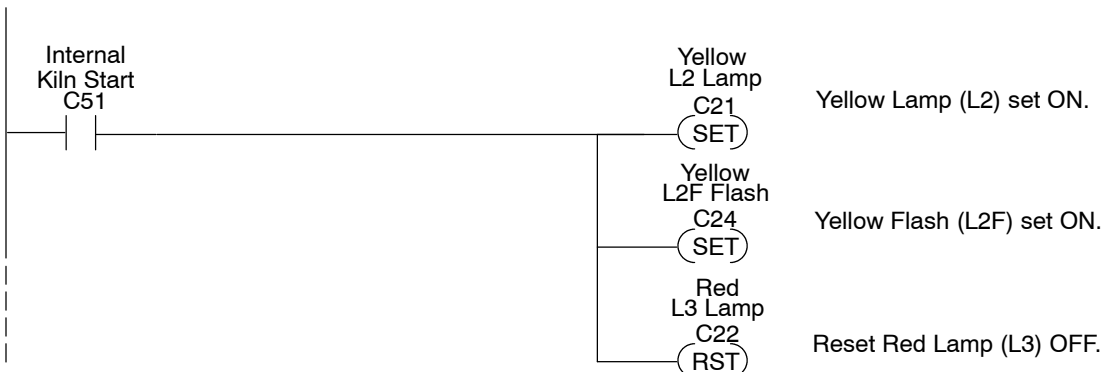

RUNG 5**Startup Delay Timer**

This delay timer signals the System Start (C52) control relay.

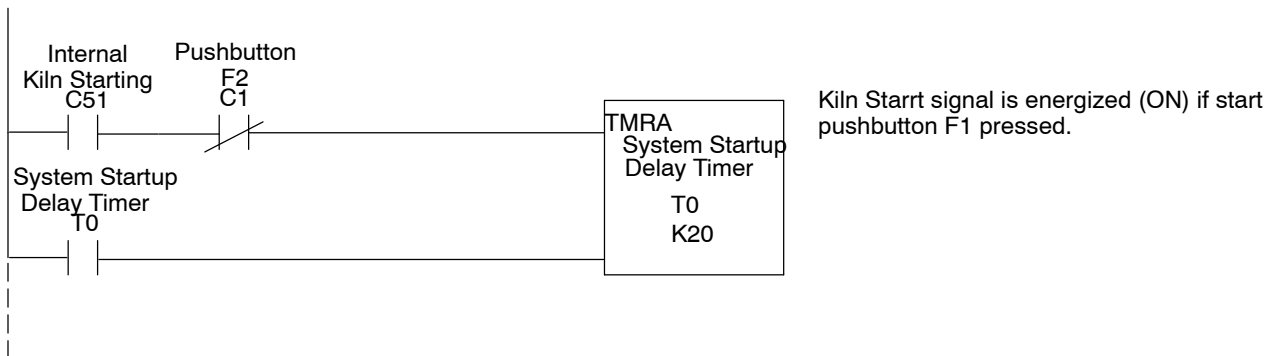
**RUNG 6****System Running**

This rung controls sets internal control relay System Running (C52) ON.

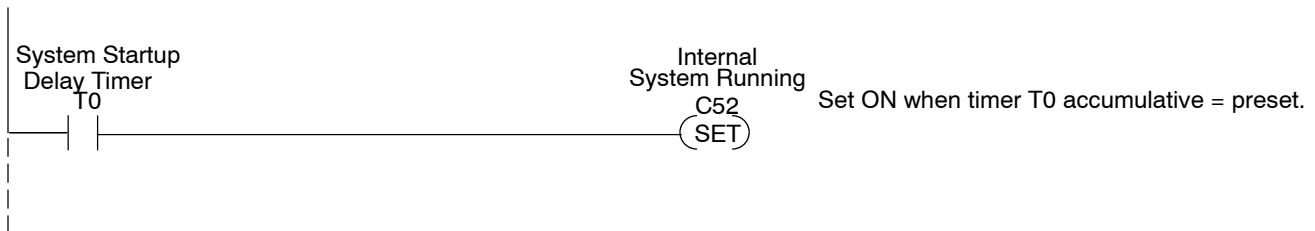
**RUNG 7****System Running Lamp Control**

This rung controls the annunciator lamps when System Running (C52) is ON.

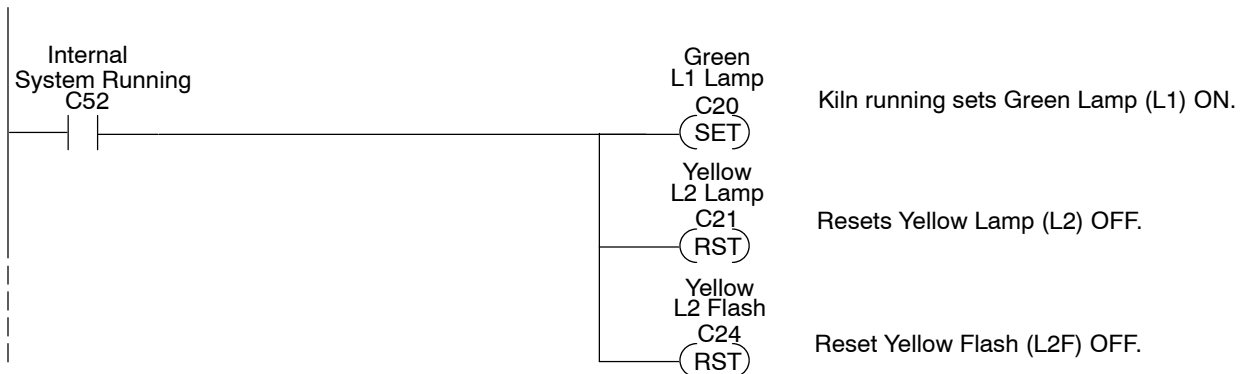
**RUNG 8**

This rung resets internal control relay (C52) System Running when alternating pushbutton 2 (F2) is OFF.

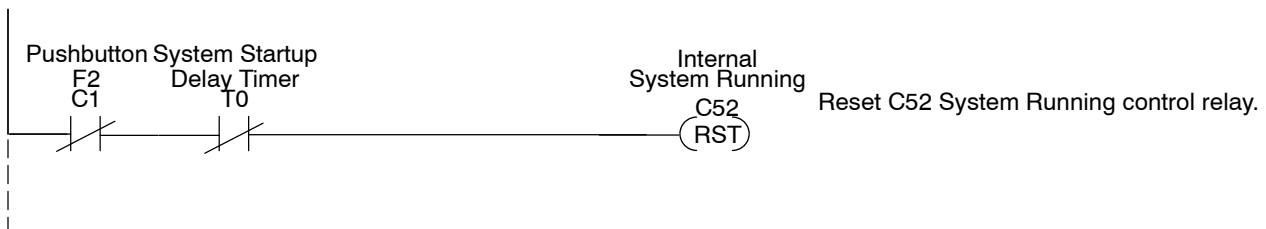

RUNG 9**Kiln Starting Message**

This rung displays "Kiln Starting" message when internal input (C51) is ON.

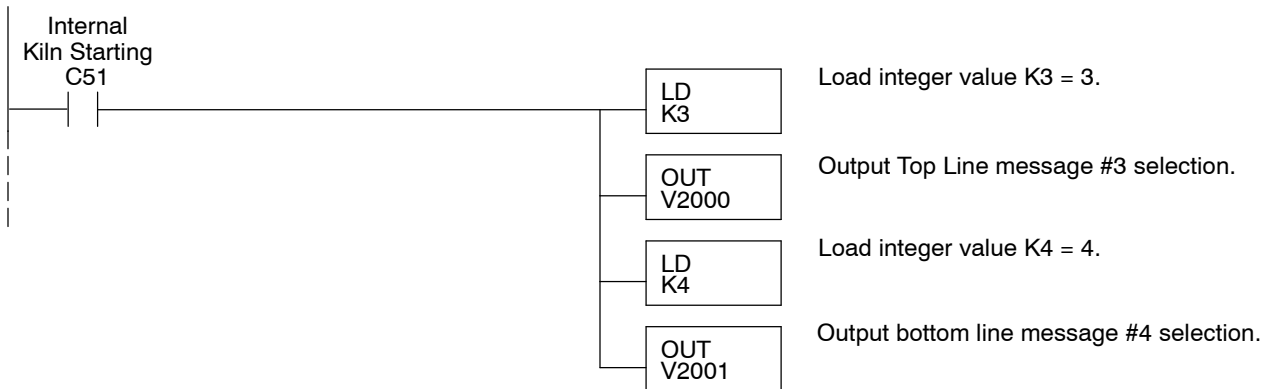
**RUNG 10****System Running Message**

This rung displays "System Running" message when internal input C52 is ON.

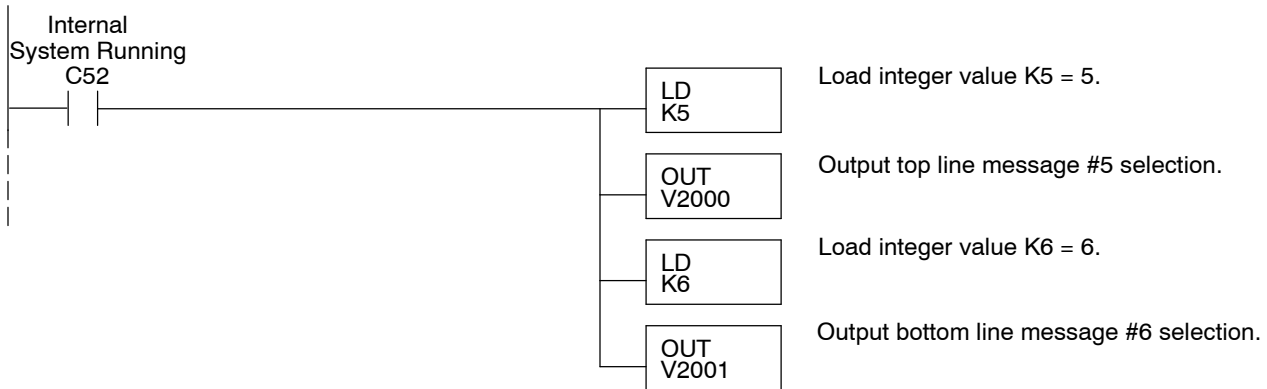
**RUNG 11****Kiln System Stopped Message**

This rung displays "Kiln System Stopped" when the system is *not* running or *not* starting and F2 (pushbutton No.2) is pressed.

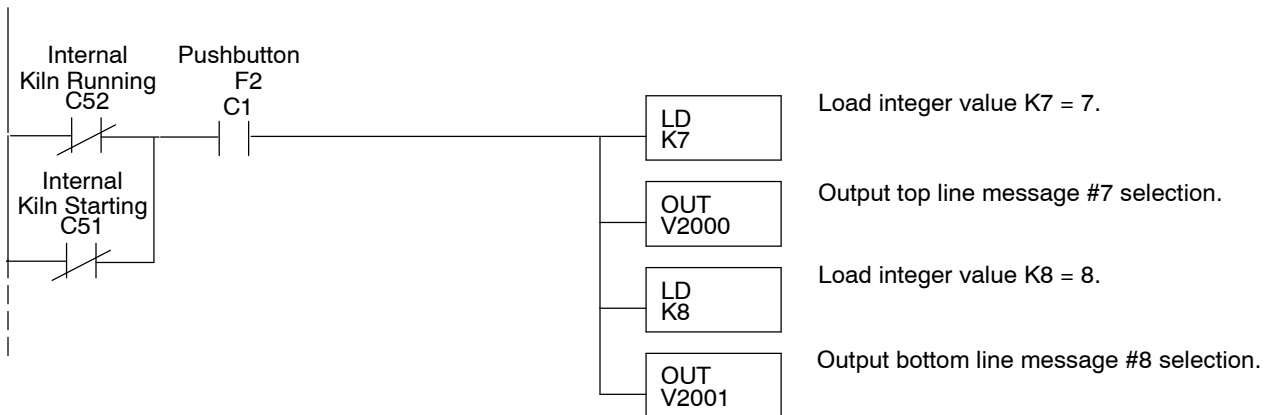

RUNG 12**Setpoint #1 Message Controls**

This rung is executed when the function select bit and Menu Enabled are ON and compare statement is equal such as menu function 1 has been selected.

The output displays the message

“Meal Hopper (1-3): ”

“Arrow UP/DOWN = ”

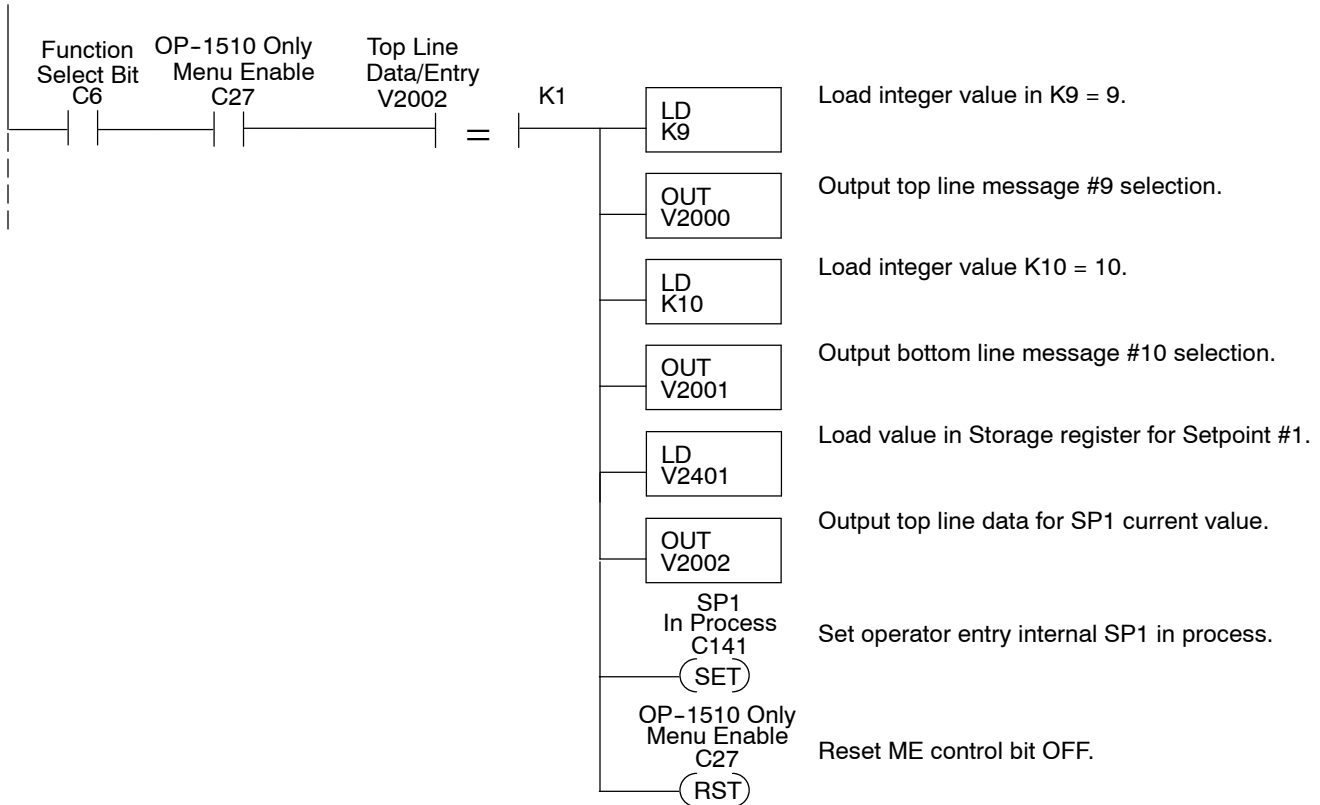
**RUNG 13****Setpoint #1 Data Storage**

This rung stores the up/down arrow value selected for Setpoint #1 after the ENTER key is pressed and Data Available status bit is ON.

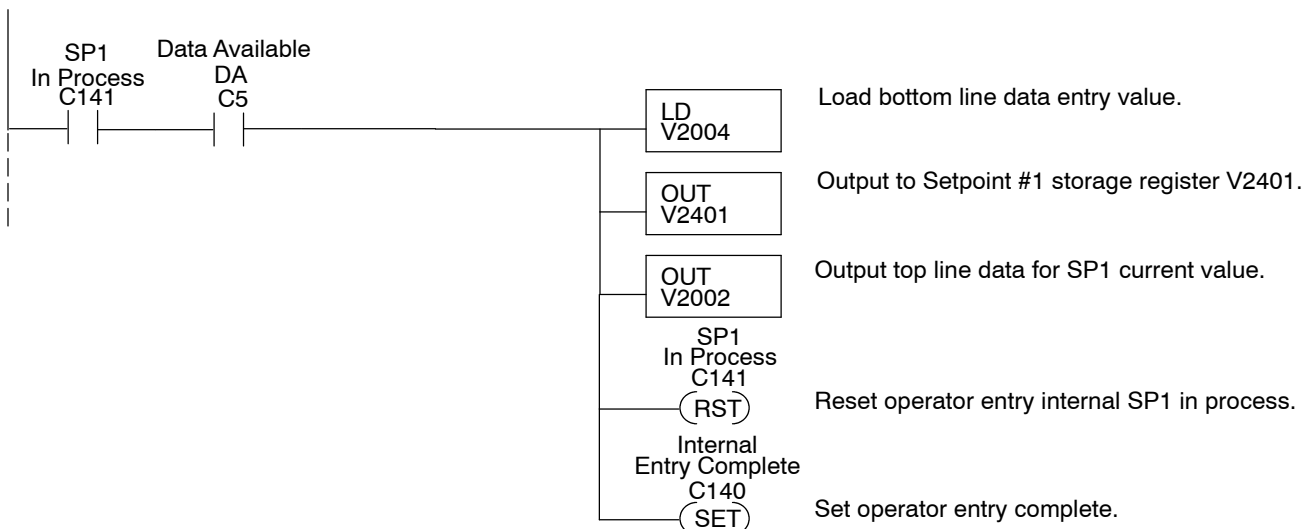

RUNG 14

Setpoint #2 Message Controls

This rung is executed when the function select bit and Menu Enabled are ON and compare statement is equal such as menu function 2 has been selected.

The output displays the message.

“Kiln Speed (%) : ”

“New Kiln Speed = ”

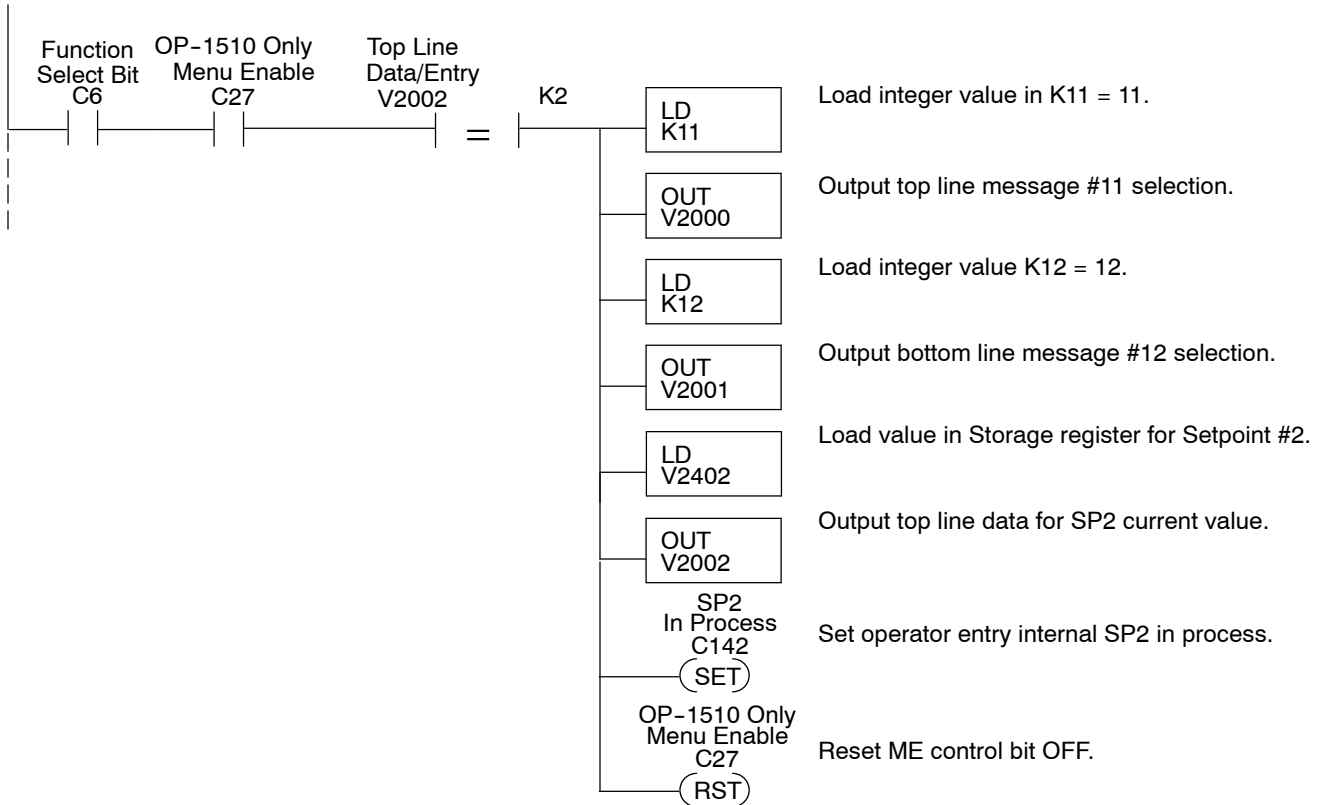

RUNG 15

Setpoint #2 Data Storage

This rung stores the keypad entry value selected for Setpoint #2 after the ENTER key is pressed and Data Available status bit is ON.

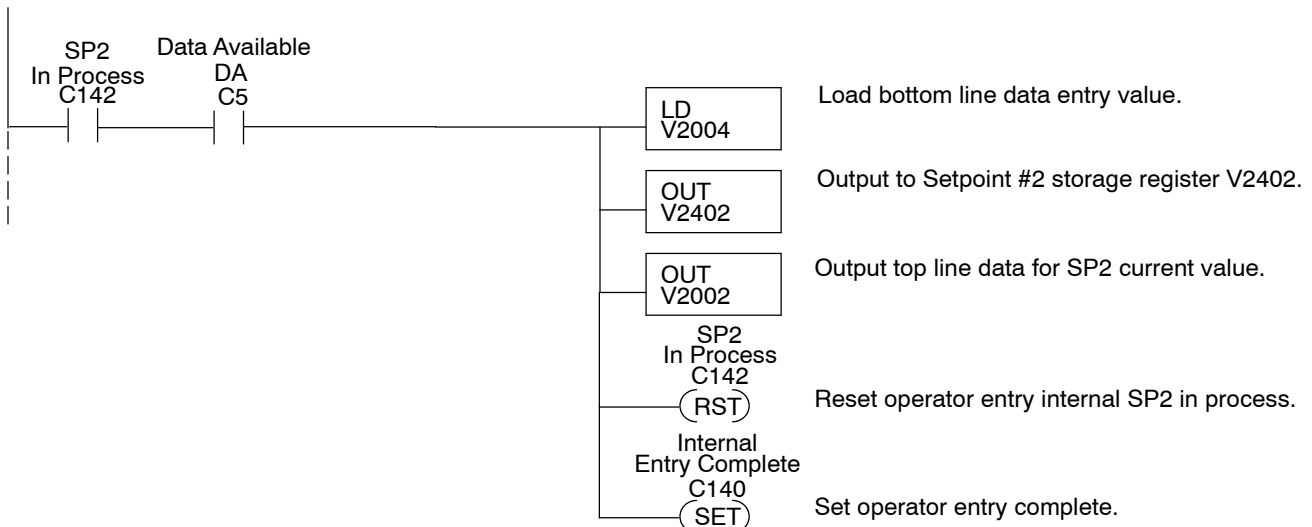

RUNG 16**Setpoint #3 Message Controls**

This rung is executed when Select key and Menu Enabled are ON and compare statement is equal such as menu function 3 has been selected.

The output displays the message

“Zone1 Temp SP : ”
“Enter New Temp.= ”

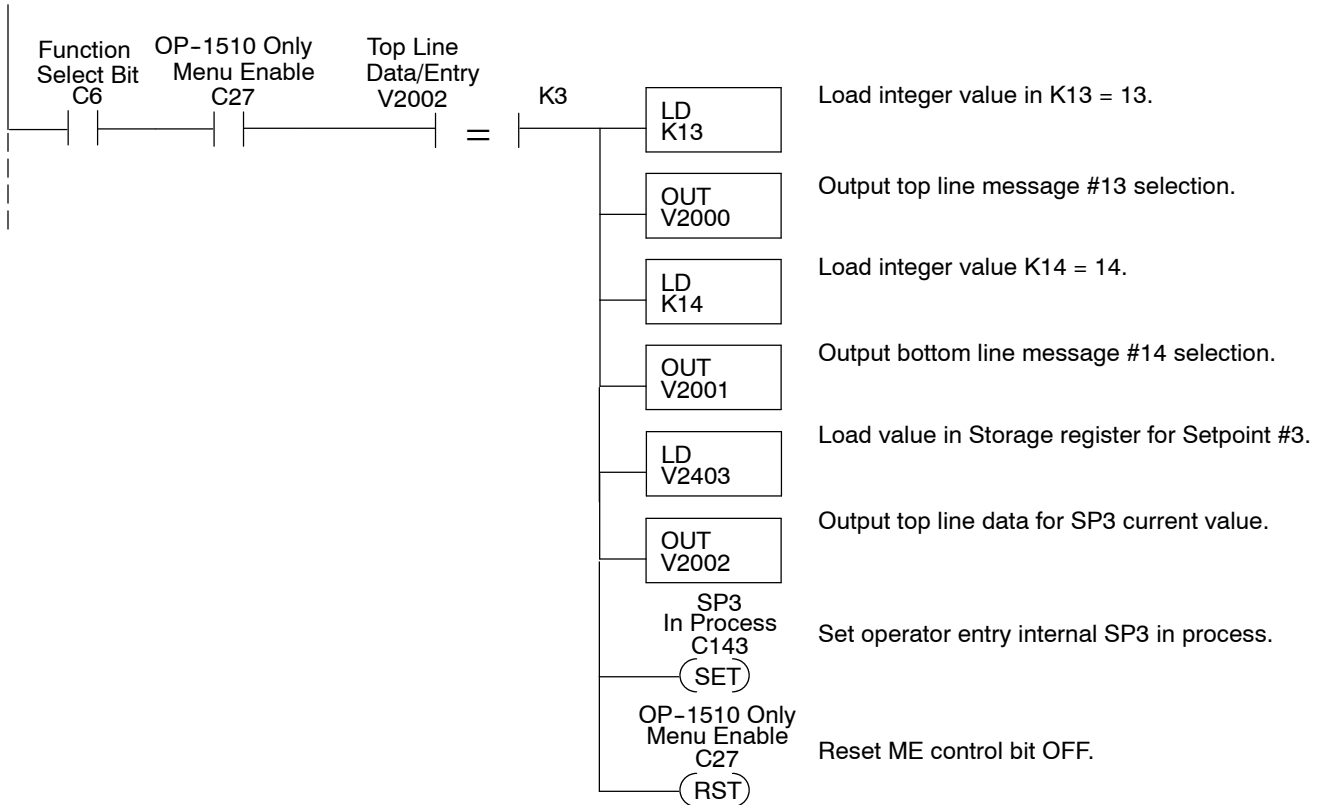
**RUNG 17****Setpoint #3 Data Storage**

This rung stores the keypad entry value selected for Setpoint #3 after the ENTER key is pressed and Data Available status bit is ON.

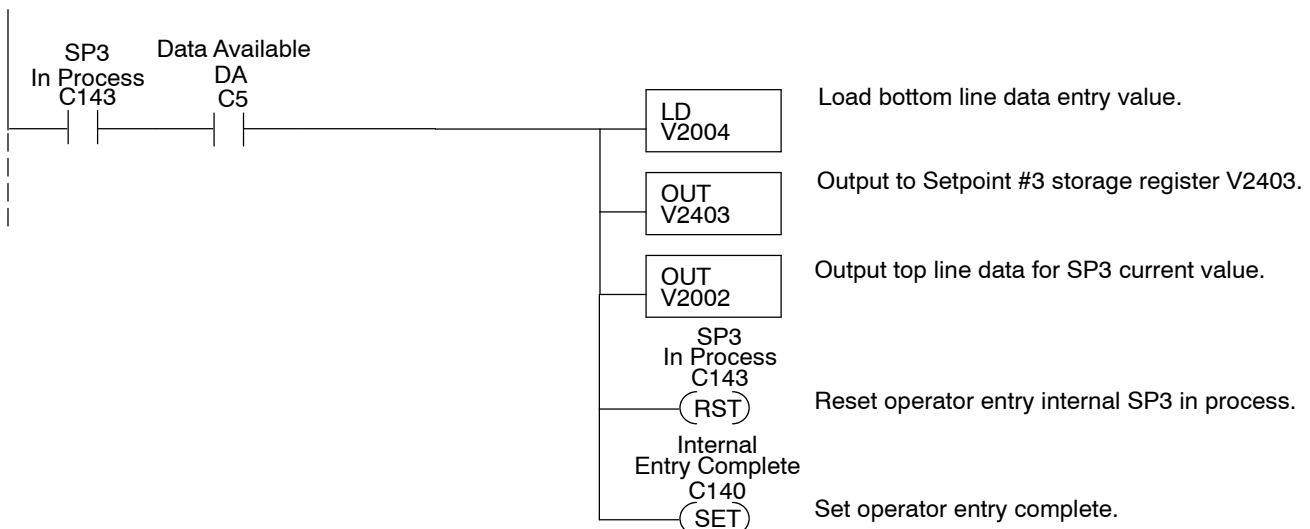

RUNG 18

Setpoint #4 Message Controls

This rung is executed when Select key and Menu Enabled are ON and compare statement is equal such as menu function 4 has been selected.

The output displays the message

“Zone2 Temp SP : ”
 “Enter New Temp.= ”

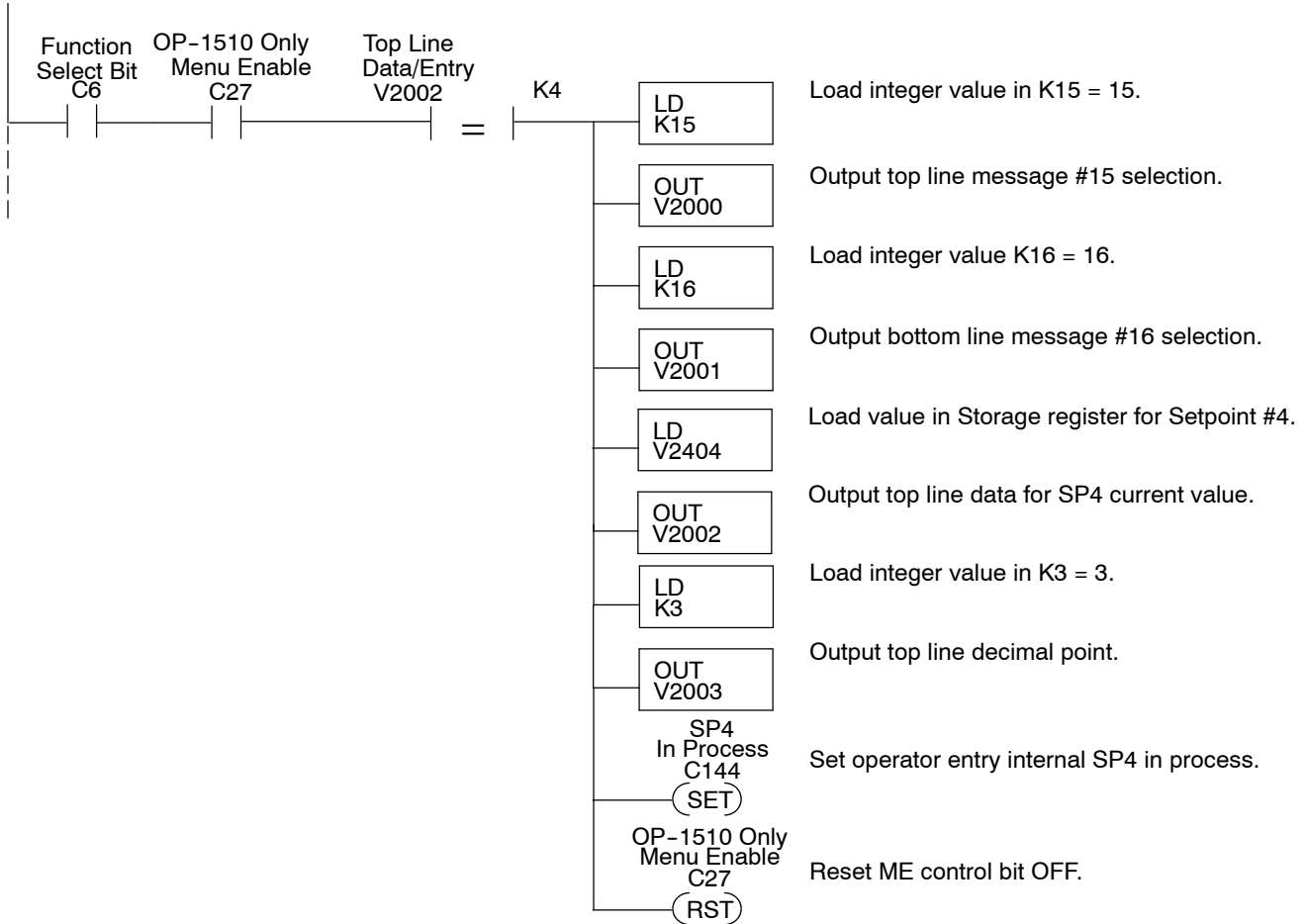

RUNG 19

Setpoint #4 Data Storage

This rung stores the keypad entry value selected for Setpoint #4 after the ENTER key is pressed and Data Available status bit is ON.

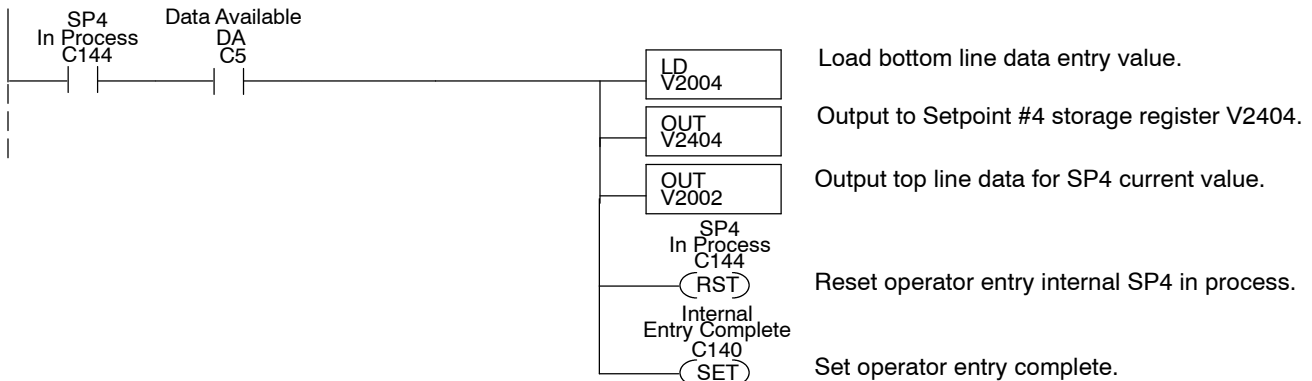

RUNG 20**Setpoint #5 Message Controls**

This rung is executed when the function select bit and Menu Enabled are ON and the compare statement is equal.

The output displays the message.

“Zone3 Temp SP : ”
“Enter New Temp.= ”

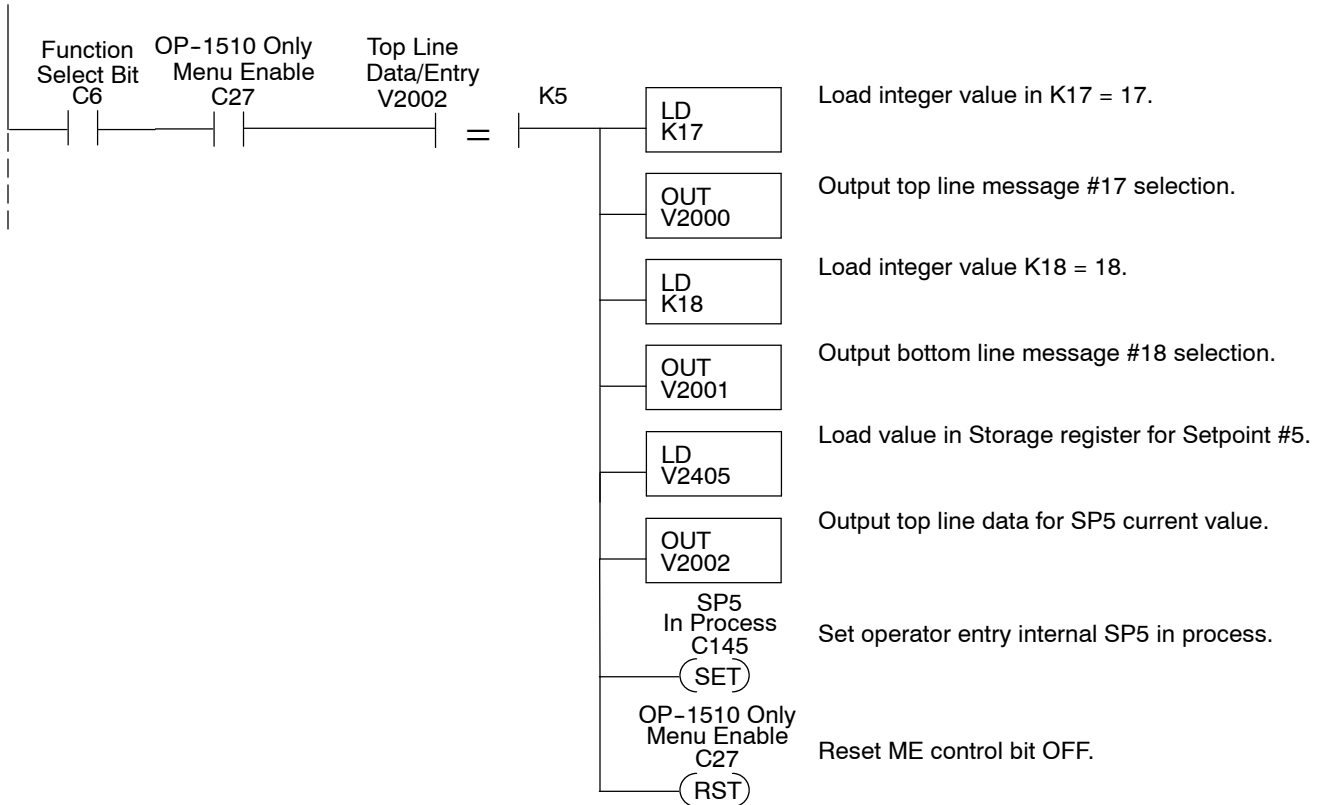
**RUNG 21****Setpoint #5 Data Storage**

This rung stores the up/down arrow value selected for Setpoint #5 after the ENTER key is pressed and Data Available status bit is ON.

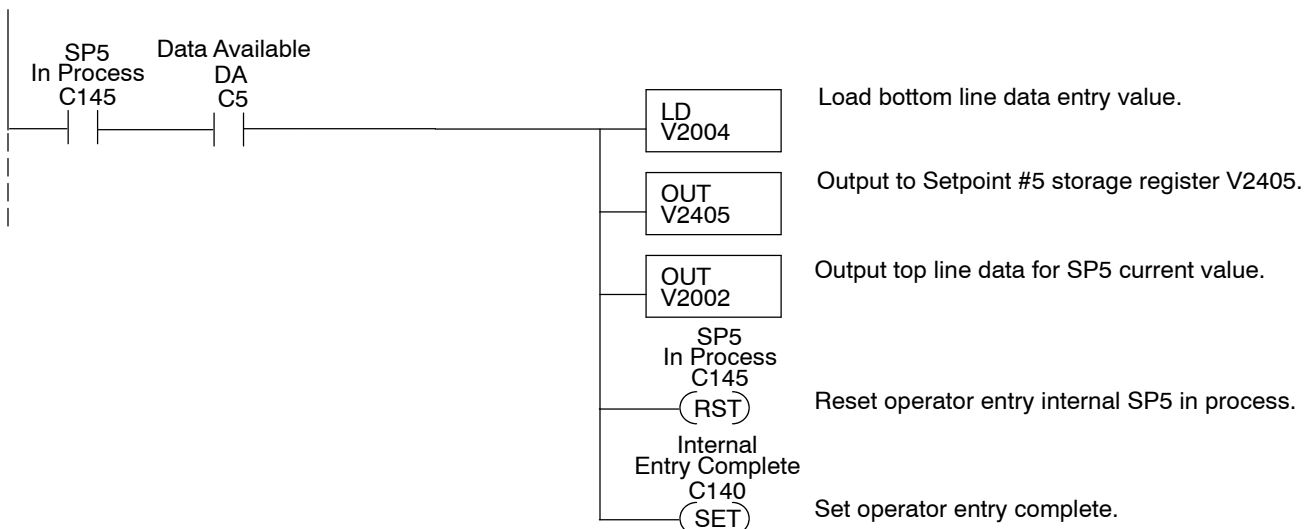

RUNG 22**Data Entry Acknowledge**

This rung controls confirmation to OP-panel that data entry and storage is complete.

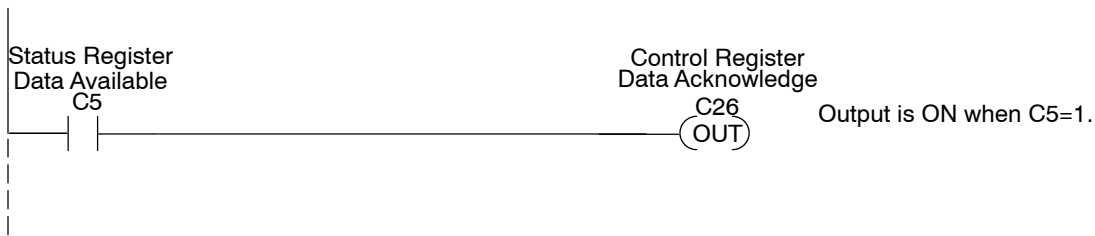
**RUNG 23****Post Entry Control**

This rung prepares the program for the next OP-panel operation.

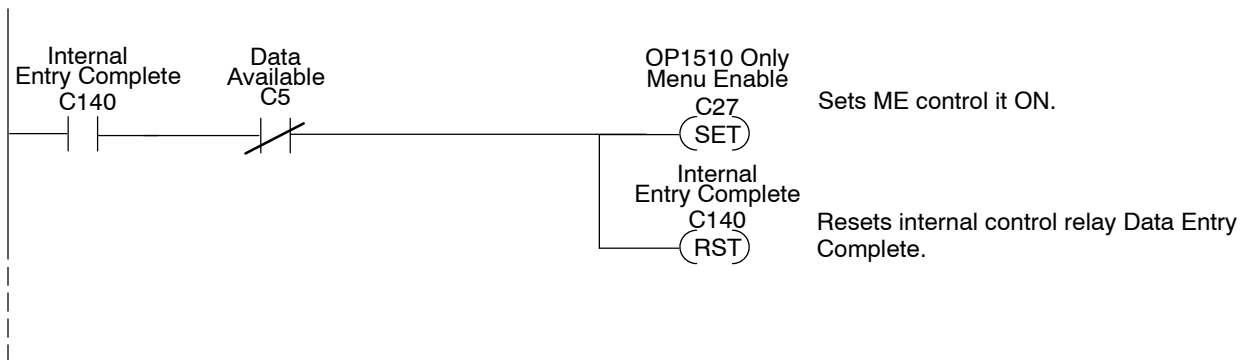
**RUNG 24****Entry Mode**

This rung sets internal relay C100 for Setpoint Entry Mode.

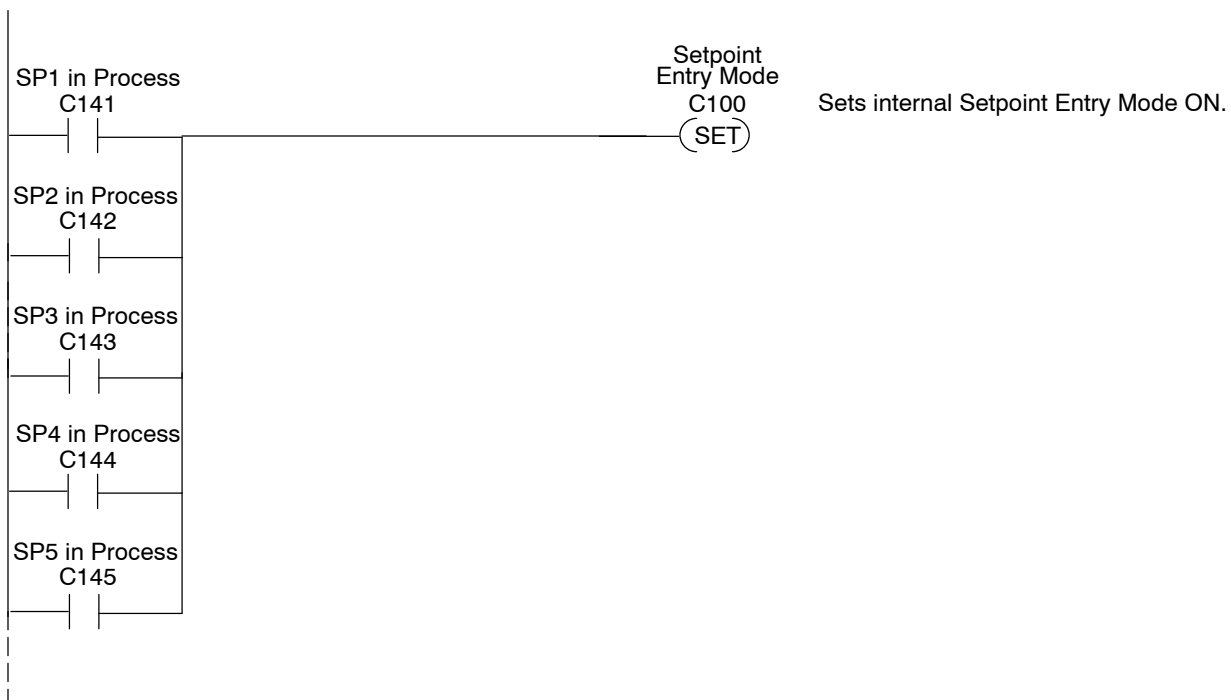

RUNG 25

Entry Mode

This rung enables menu operations and resets the setpoint in process for Setpoint Entry Mode interlocking.

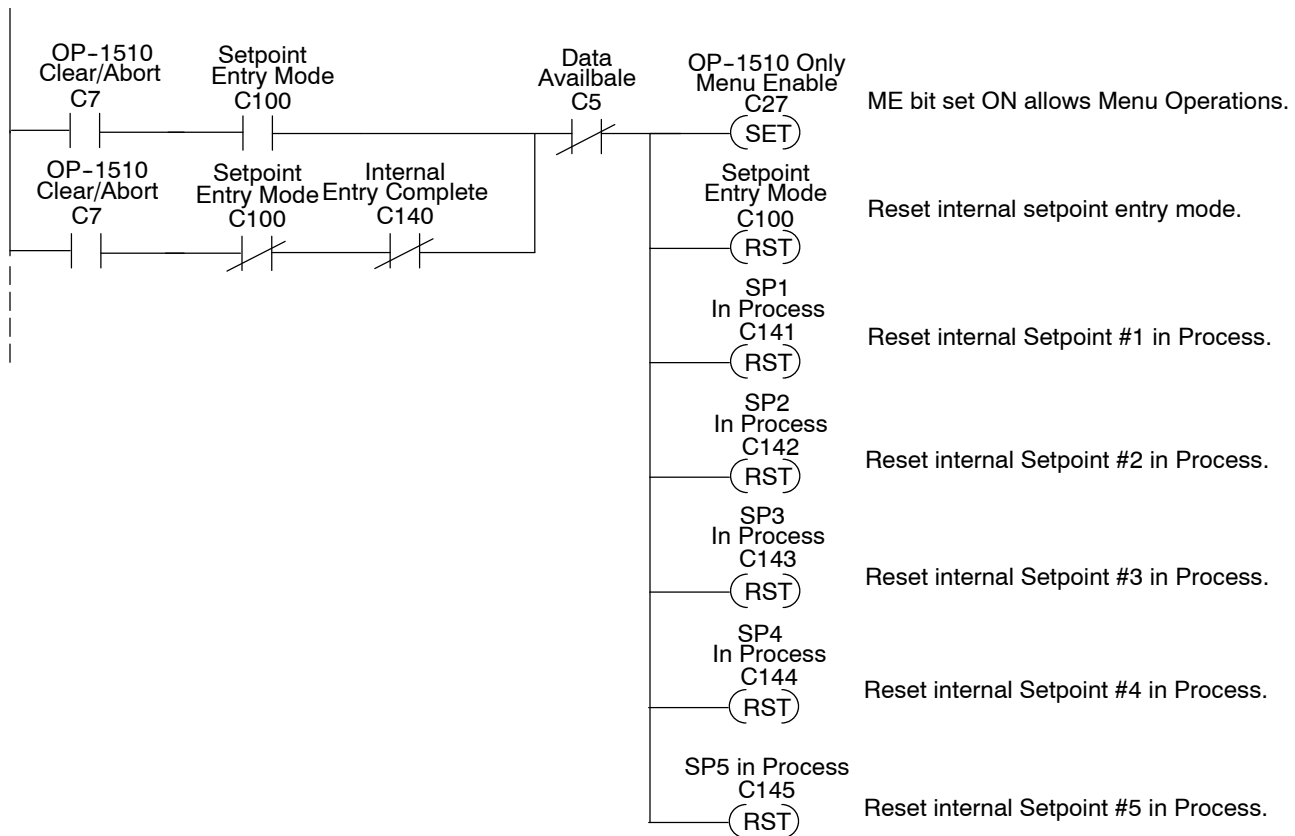

RUNG 26

End of program

This rung marks the END of program.





Appendix C

DL 305

Application Example

In This Appendix. . . .

— DL305 Program Example (DL330/DL340 Only)

Understanding the Example Programs

The following example program uses a Cement Kiln System to demonstrate the ladder logic required to support the various OP-panel features. The program provides ladder logic which supports controlling pushbuttons, lamps, messages and menu operations.

For training purposes the items listed in the figure below such as Hopper Selection, Kiln Speed, Kiln Zone Temperatures are monitored and controlled by the OP-panel example programs.

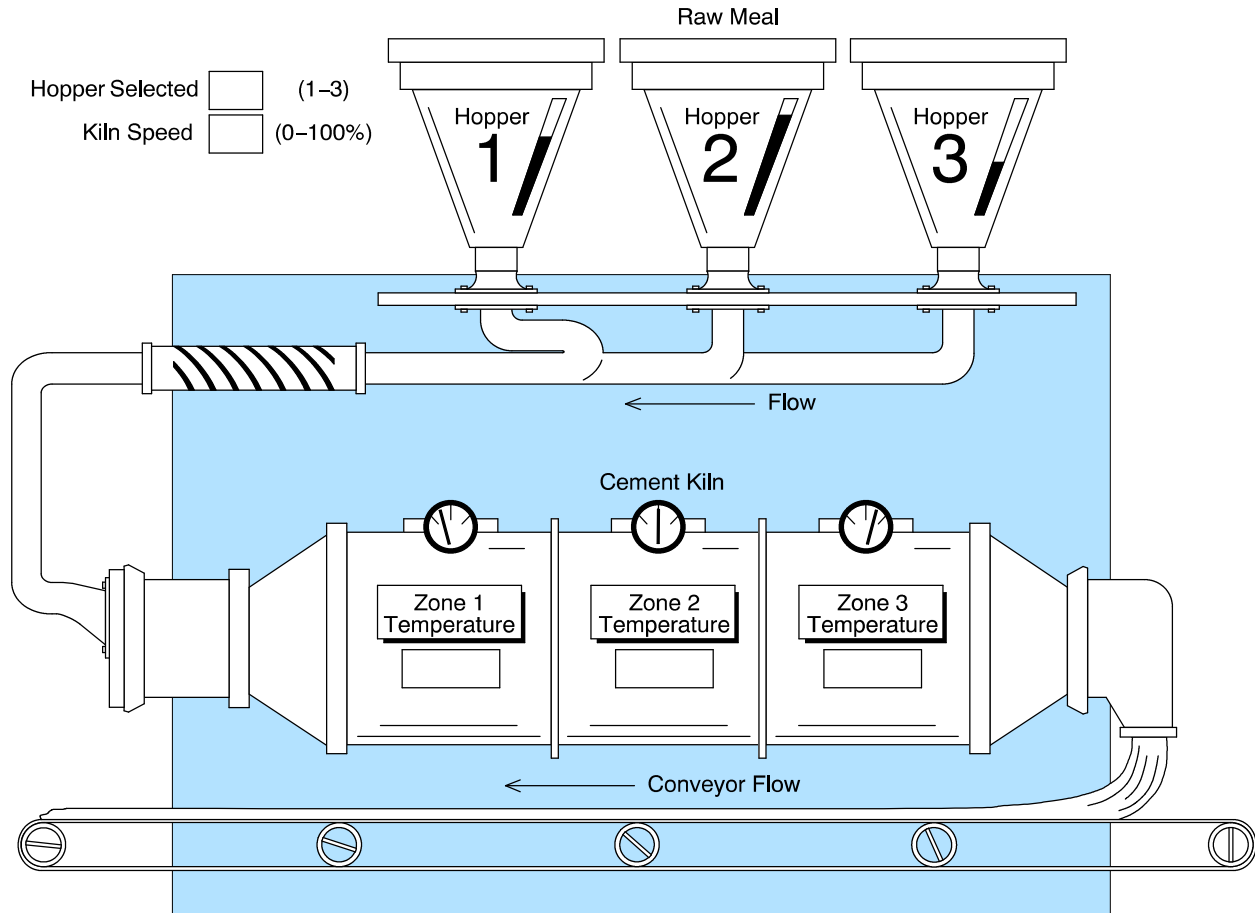

The example program listed on the following pages is designed for **DirectLOGIC** DL305 PLC systems. The program is included on the 3 1/2 inch floppy disk provided with this manual.

These same example programs and additional technical support information may be accessed on **PLCDirect**'s **worldwide web** site:

<http://www.plcdirect.com> (website for general info/file transfers)

You may also find these programs on our 24-hour per day **BBS** system at:

770-844-4209

If you find a problem with any of our products, services, or manuals, please fill out and return the 'Suggestions' card that was shipped with this manual.

DirectLOGIC DL305 Example Program

The example program listed on the following pages is designed for **DirectLOGIC** DL305 PLC systems. The program supports the OP-1510 Kiln Demo application. This program is included on the 3 1/2 disk labeled "OP-1500/OP-1510 Example Disk" which is provided with this manual.



a:\1510_305.prj

This example program (1510_305.PRJ) should be used with the OP-1510 configuration file 1510_305.OCF. Load these program files to the PLC and OP-panel for connection and operation of the Kiln Demo application. You may also refer to the Appendix A "Example Worksheets" to help understand how the OP-panel is configured.

OP-1510 Kiln Demo

This program is designed to be used with the **DirectLogic** DL305 and compatible systems. The following program is intended for training purposes and *may not* resolve all possible OP-panel applications. Some PLC programming knowledge is required to fully understand and implement the following program examples.

RUNG 1

If the CPU power cycles or machine and operator conditions are idle this rung will initialize OP-panel and display message #1 and message #2.

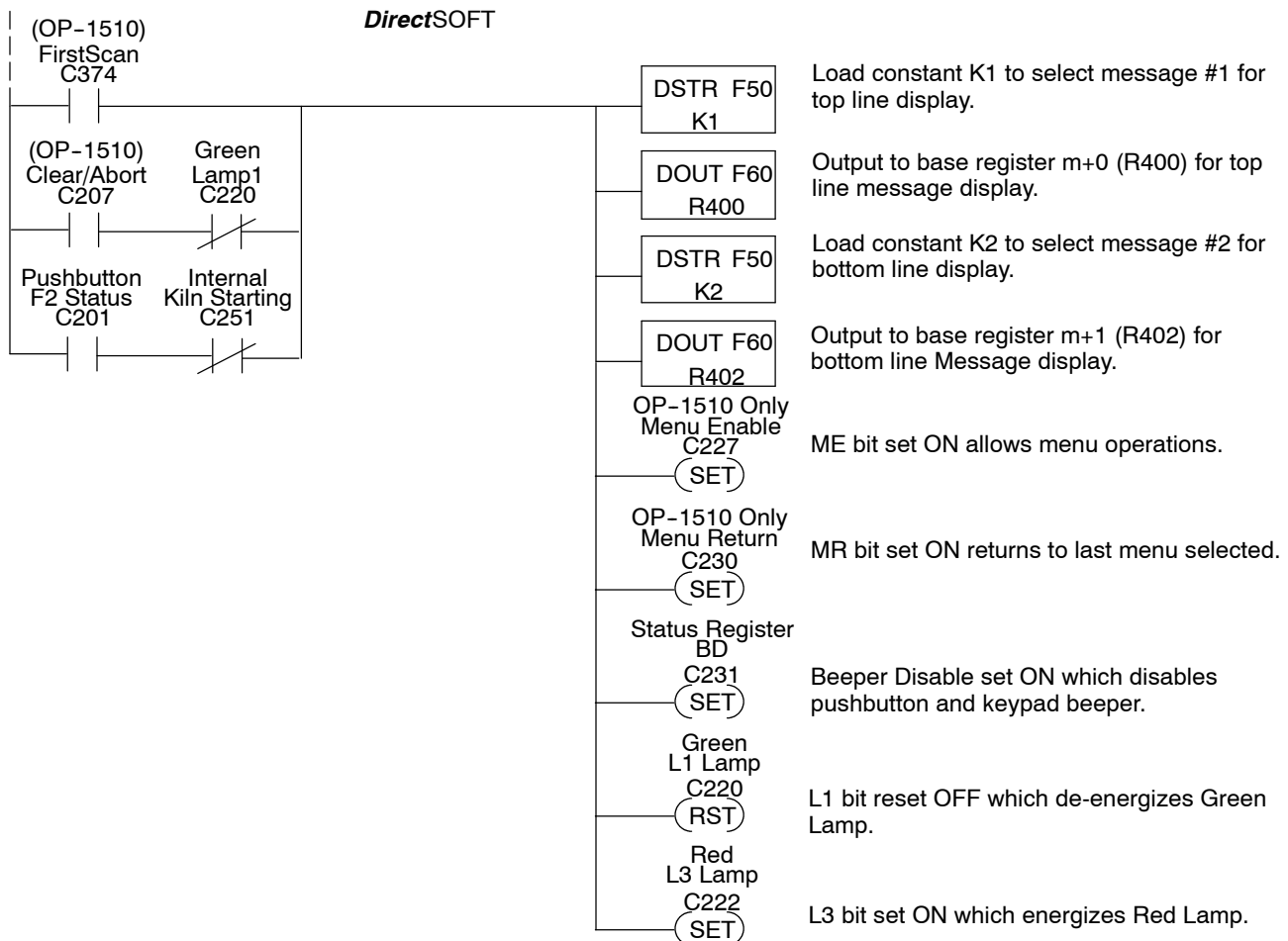

RUNG 2

Memory Mapping

This rung is necessary for all *Direct*LOGIC CPUs which *do not* support bit of word instructions. Mapping the Status and Control registers into internal control relays is necessary to have bit level access to this data. The Status and Control register bits are used to monitor pushbuttons, control lamps, and perform asynchronous data exchange between the OP-panel and PLC.

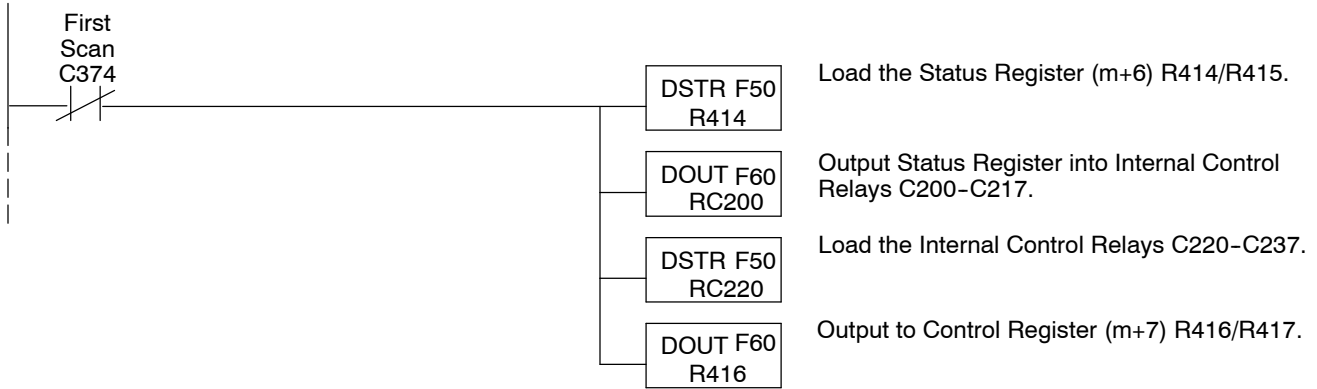

RUNG 3

Kiln Start Control

This rung starts the machine process. The internal control relay Kiln Start (C251) is used to start the Startup Delay Timer, and will remain ON until the L1 control register bit (C220) is energized.

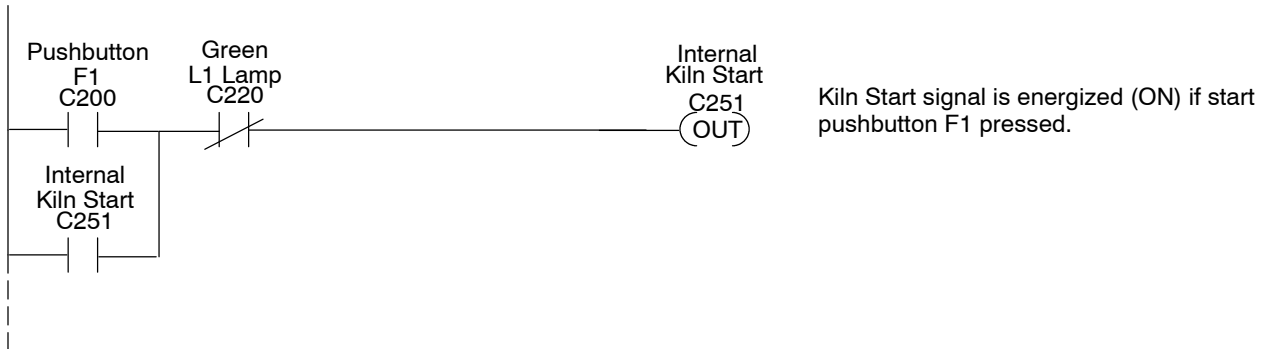

RUNG 4

Kiln Starting Lamp Control

This rung controls the annunciator lamps during startup mode.

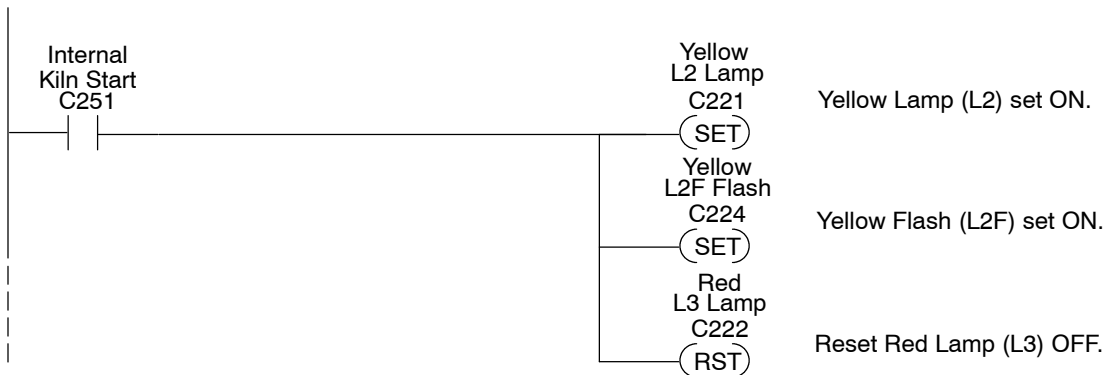

RUNG 5

Startup Delay Timer

This delay timer signals the System Running (C252) control relay.

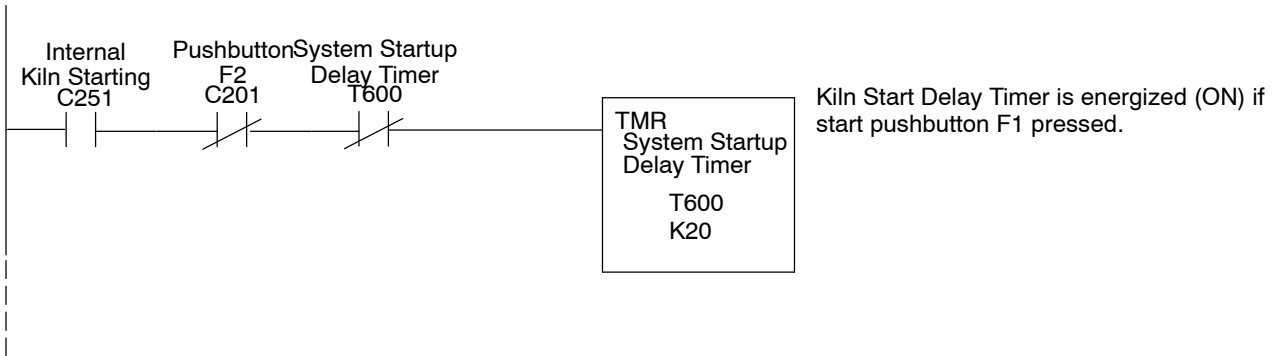

RUNG 6

System Running

This rung sets internal control relay (C252) System Running (C52) ON.

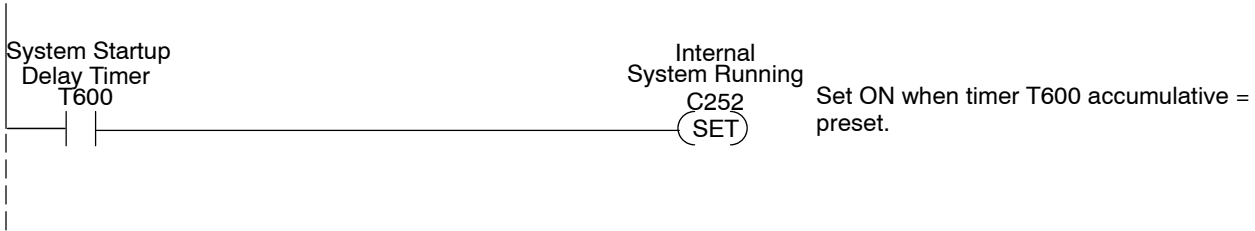

RUNG 7

System Running Lamp Control

This rung controls the annunciator lamps during startup mode.

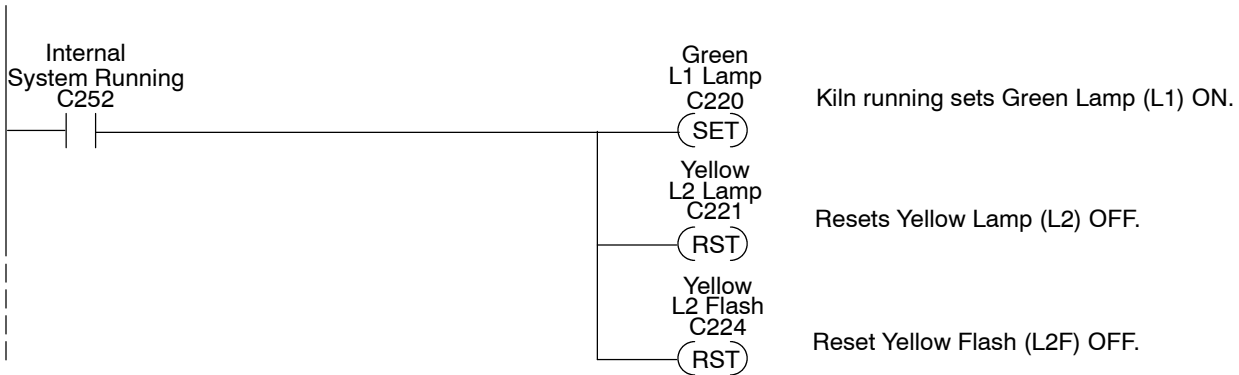

RUNG 8

Reset System Running

This rung resets internal control relay (C252) System Running when alternating pushbutton 2 (F2) is OFF.

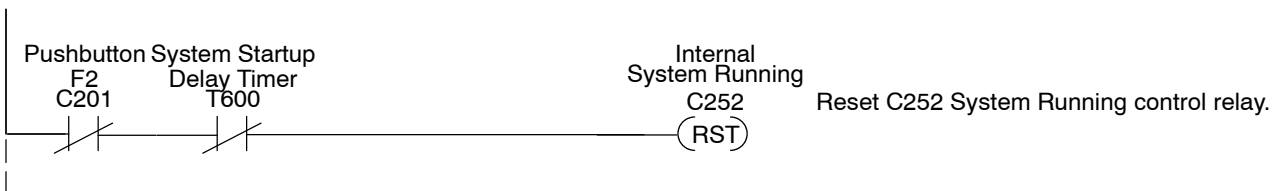

RUNG 9

Kiln Starting Message

This rung displays "Kiln Starting" message when internal (C251) is ON.

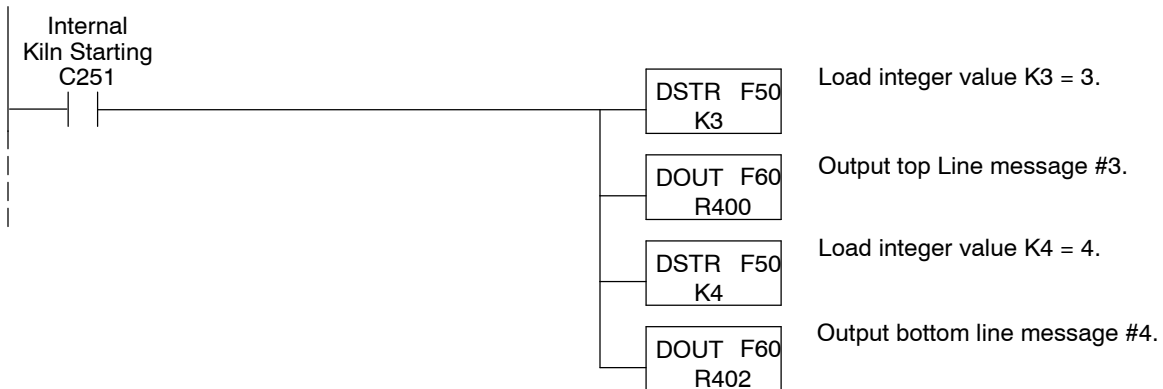

RUNG 10

System Running Message

This rung displays the "System Running" message when internal input (C252) is ON.

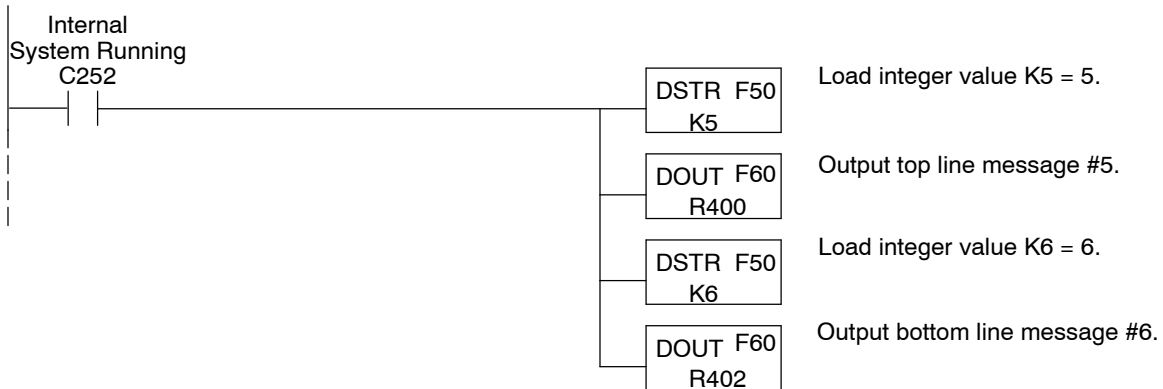

RUNG 11

Kiln System Stopped Message

This rung displays "Kiln System Stopped" when the system is *not* running or *not* starting and F2 (pushbutton 2) is pressed.

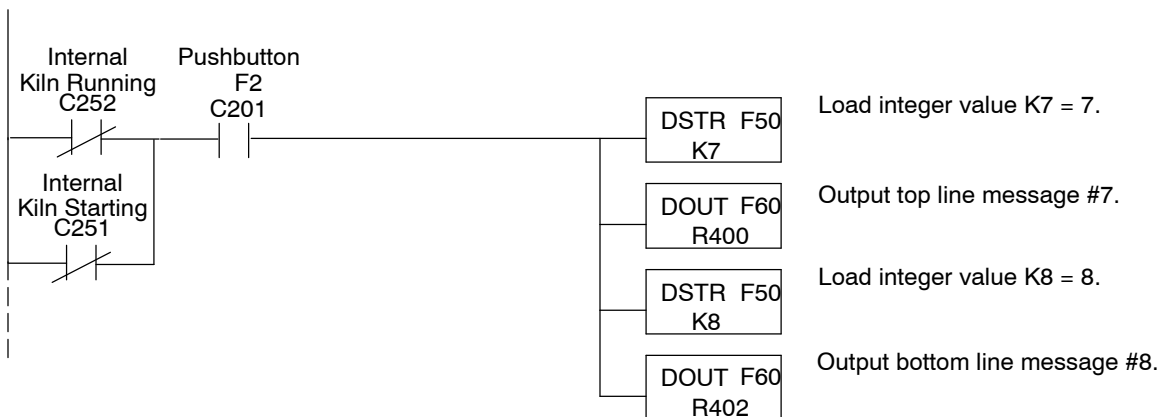

RUNG 12**Maps R404 (Function Select) to R610**

The DL305 only allows the compare statement when using timer and counter registers. This rung maps the function selection number into Timer/Counter registers for compare statement.

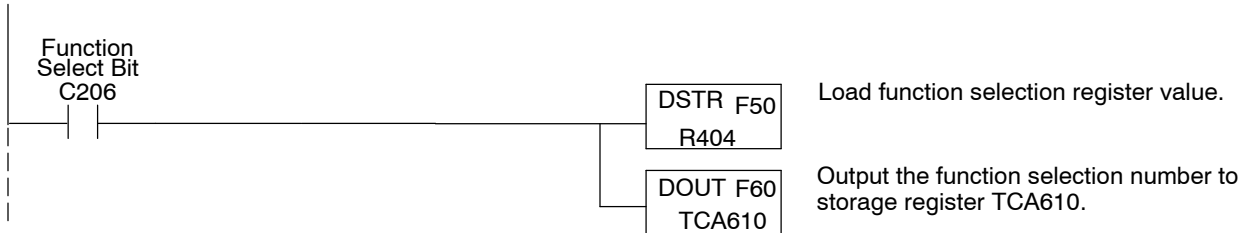
**RUNG 13****Setpoint #1 Message Controls**

This rung is executed when the Function Select Bit and Menu Enabled are ON and the compare statement is equal such as menu function 1 has been selected.

The output displays the message

“Meal Hopper (1-3): ”
 “Arrow UP/DOWN = ”

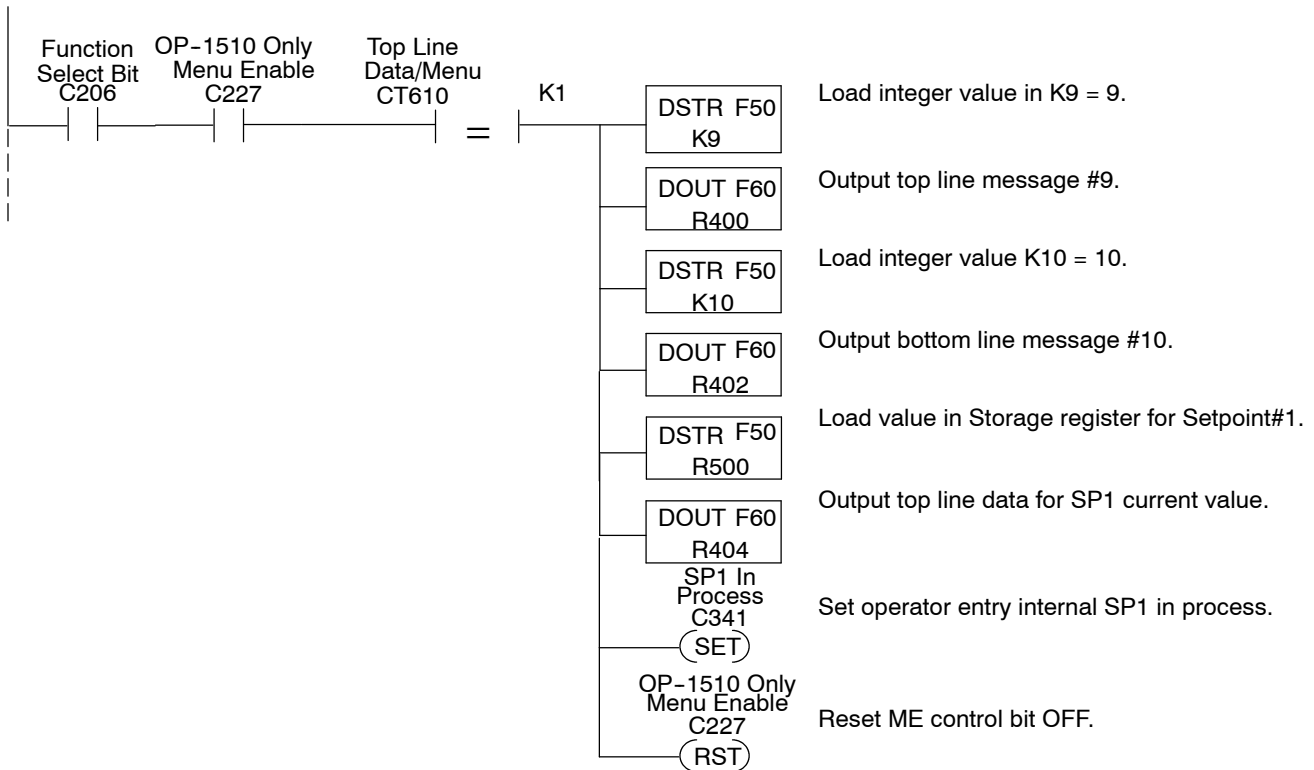

RUNG 14**Setpoint #1 Data Storage**

This rung stores the up/down arrow value selected for Setpoint #1 after the ENTER key is pressed and Data Available status bit is ON.

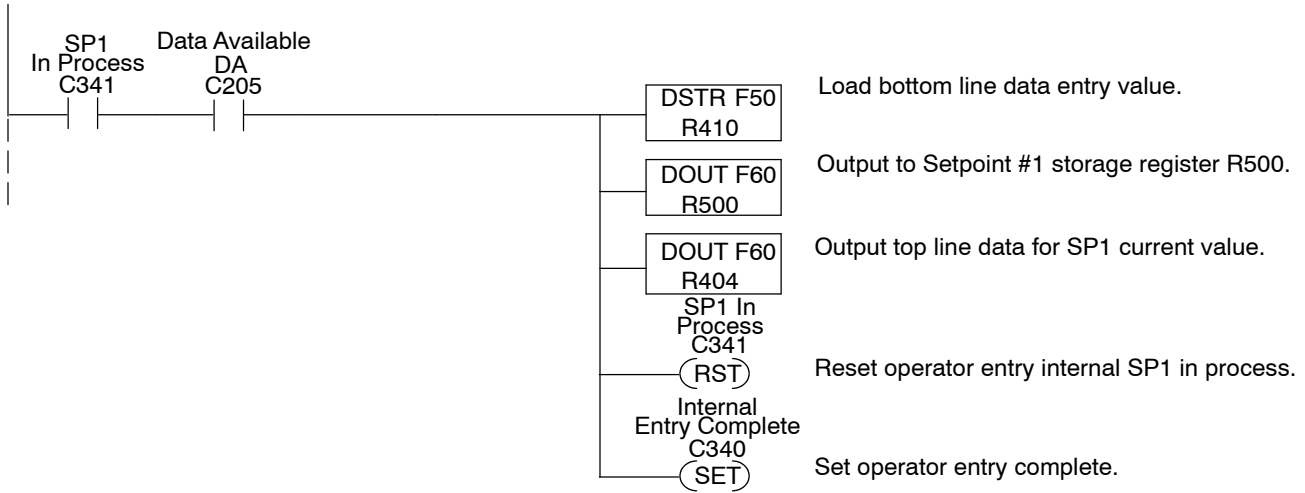

RUNG 15

Setpoint #2 Message Controls

This rung is executed when the Function Select Bit and Menu Enabled are ON and the compare statement is equal such as menu function 2 has been selected.

The output displays the message

“Kiln Speed (%) : ”
 “New Kiln Speed = ”

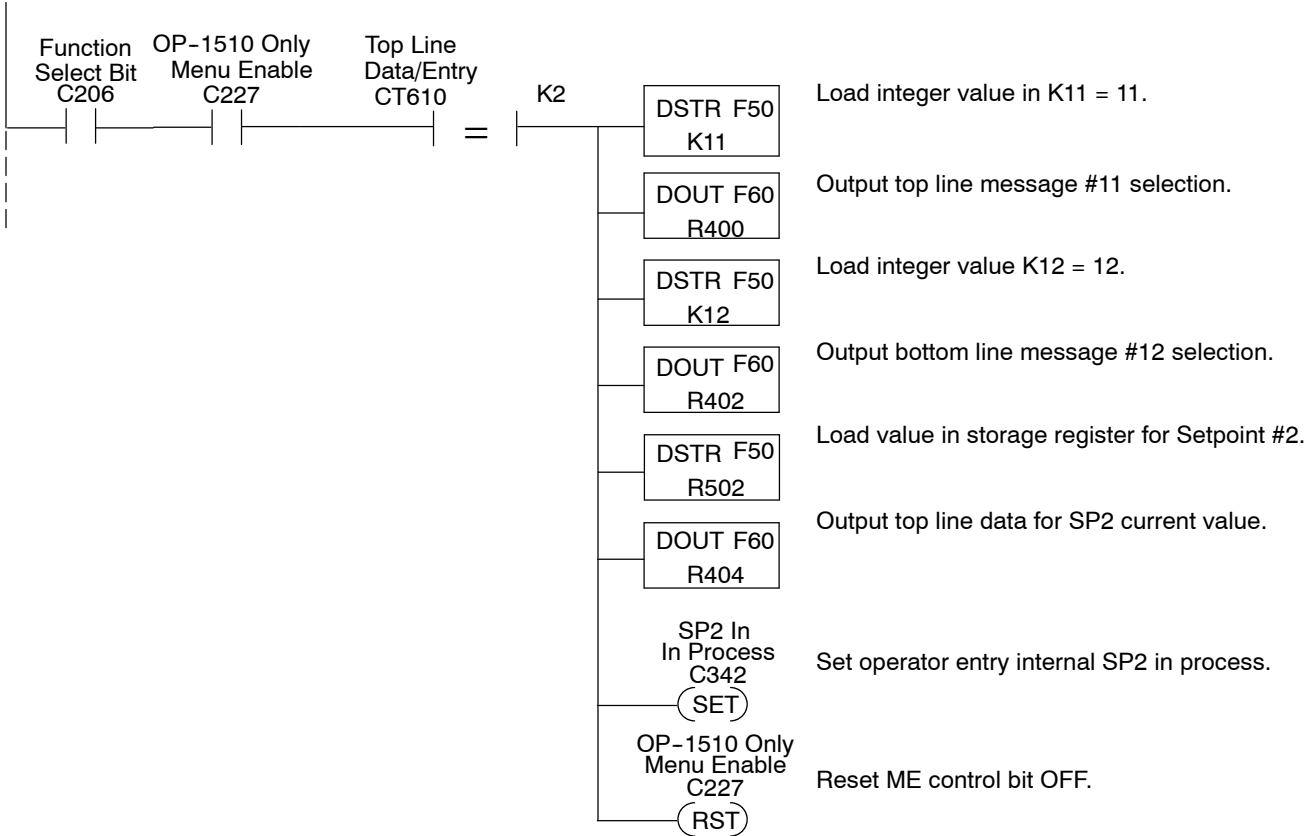

RUNG 16

Setpoint #2 Data Storage

This rung stores the keypad entry value for Setpoint #2 after the ENTER key is pressed and Data Available status bit is ON.

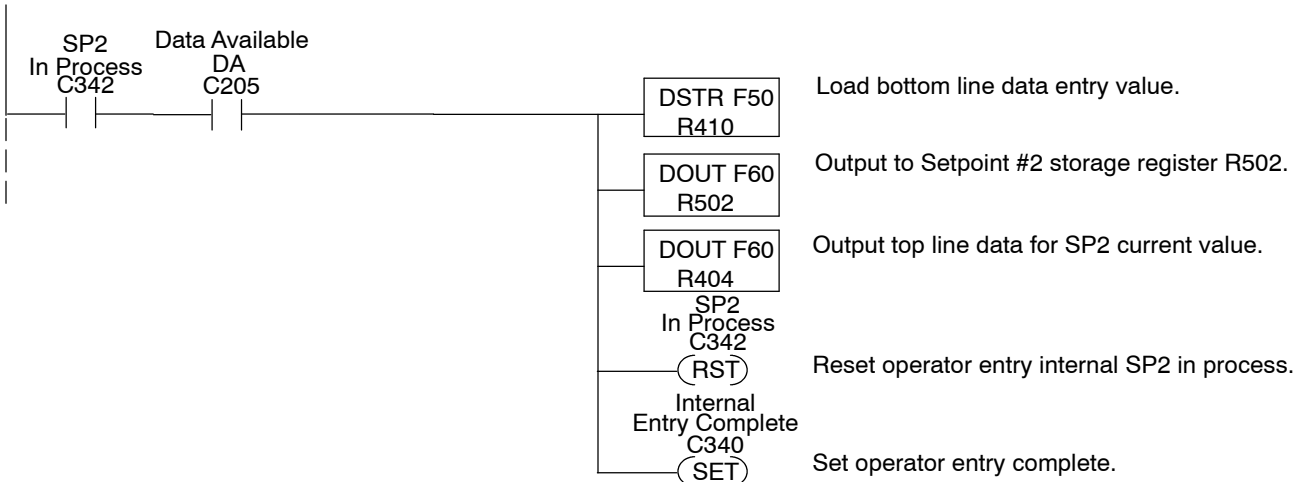

RUNG 17

Setpoint #3 Message Controls

This rung is executed when the Function Select Bit and Menu Enabled are ON and the compare statement is equal such as menu function 3 has been selected.

The output displays the message

“Zone1 Temp SP : ”

“Enter New Temp.= ”

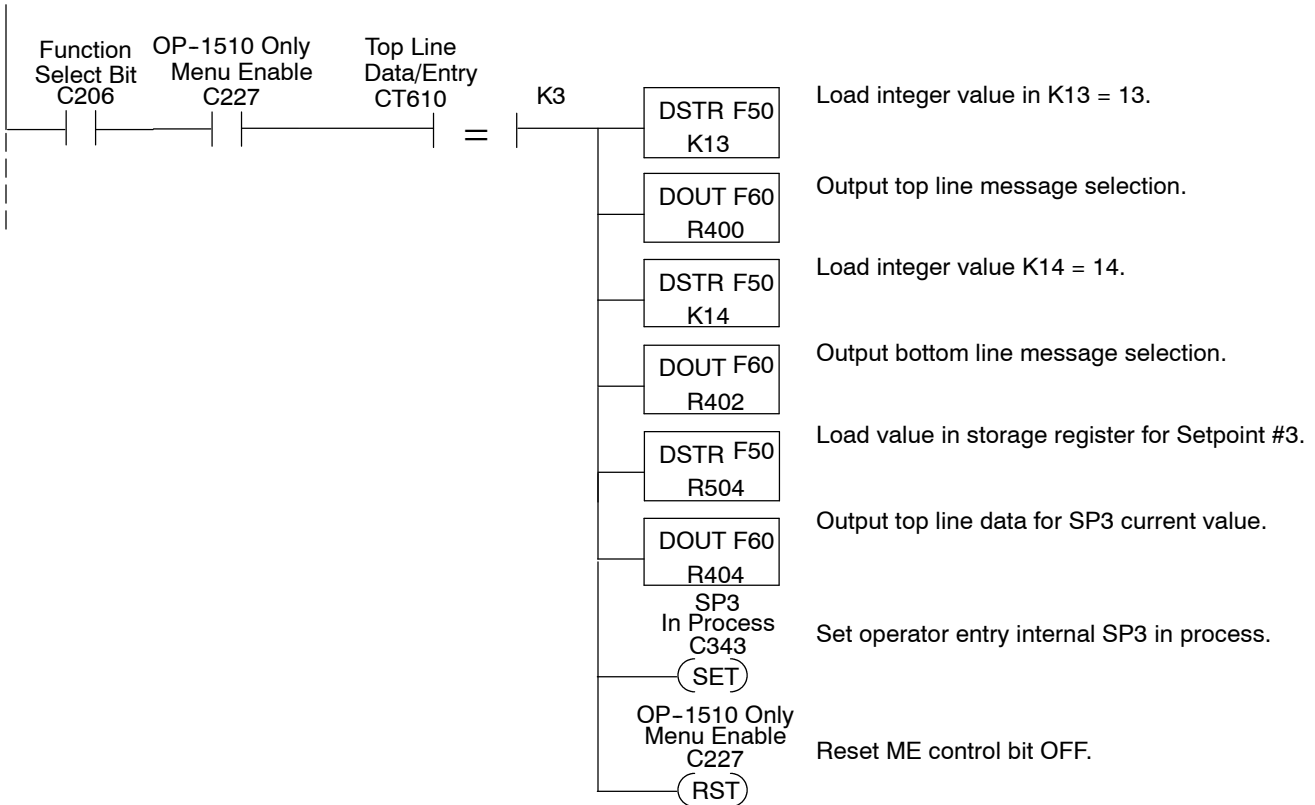

RUNG 18

Setpoint #3 Data Storage

This rung stores the keypad entry value selected for Setpoint #3 after the ENTER key is pressed and Data Available status bit is ON.

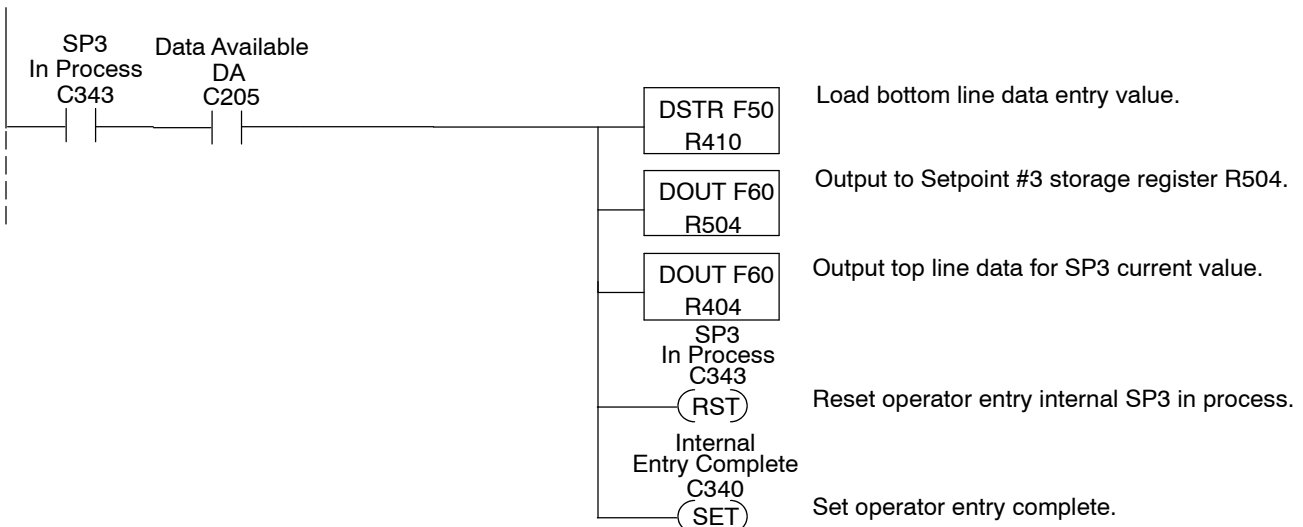

RUNG 19

Setpoint #4 Message Controls

This rung is executed when the Function Select Bit and Menu Enabled are ON and the compare statement is equal such as menu function 4 has been selected.

The output displays the message

“Zone2 Temp SP : ”
 “Enter New Temp.= ”

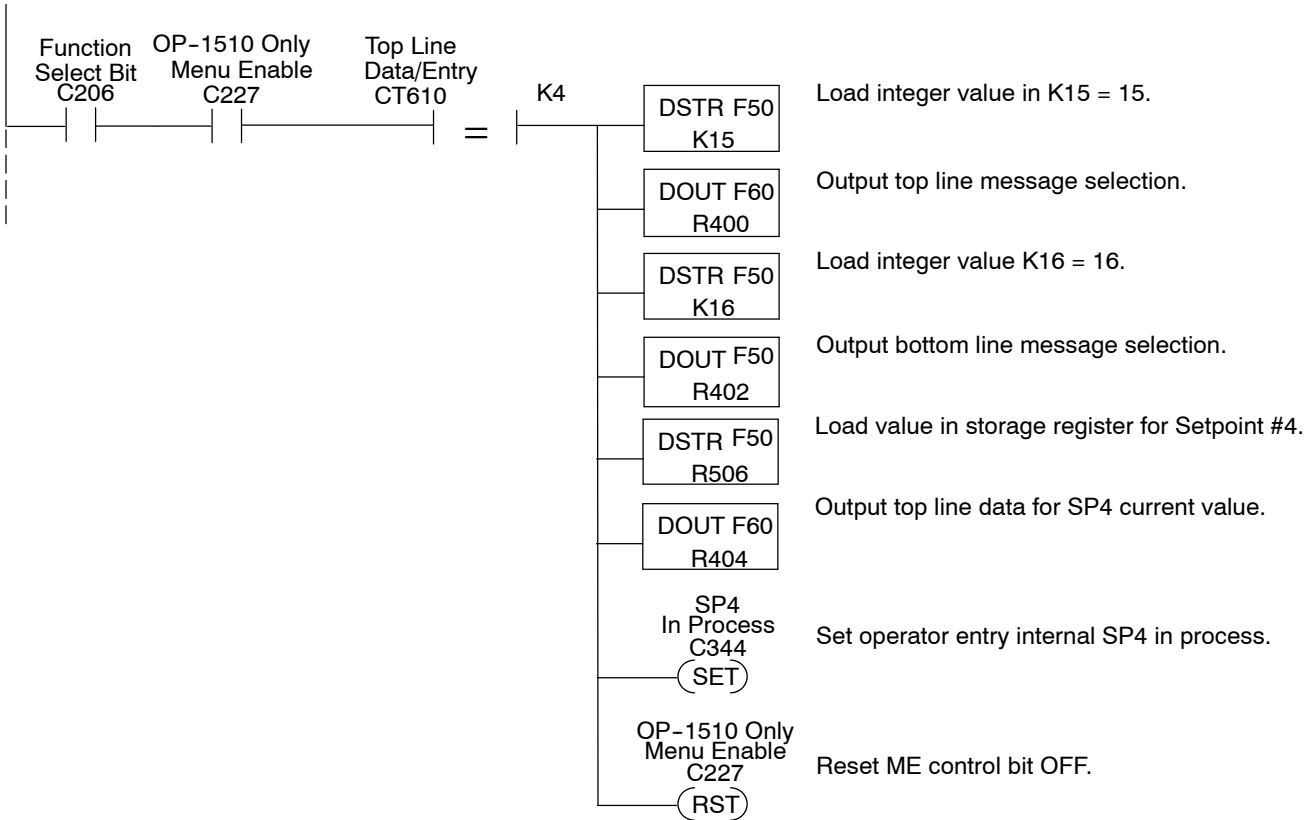

RUNG 20

Setpoint #4 Data Storage

This rung stores the keypad entry value selected for Setpoint #4 after the ENTER key is pressed and Data Available status bit is ON.

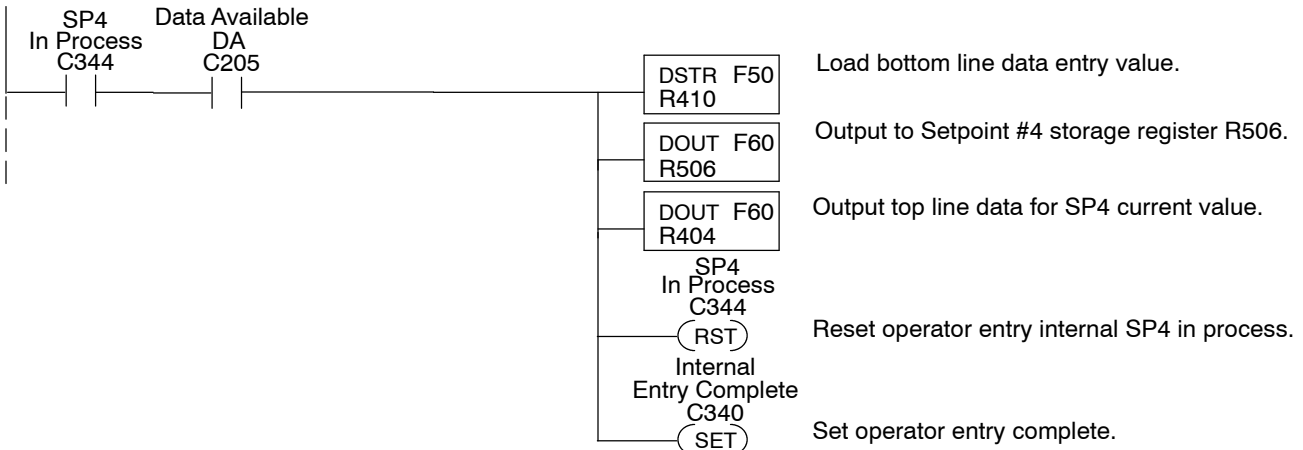

RUNG 21

Setpoint #5 Message Controls

This rung is executed when the Function Select Bit and Menu Enabled are ON and the compare statement is equal such as menu function 5 has been selected.

The output displays the message

“Zone3 Temp SP : ”
 “Enter New Temp.= ”

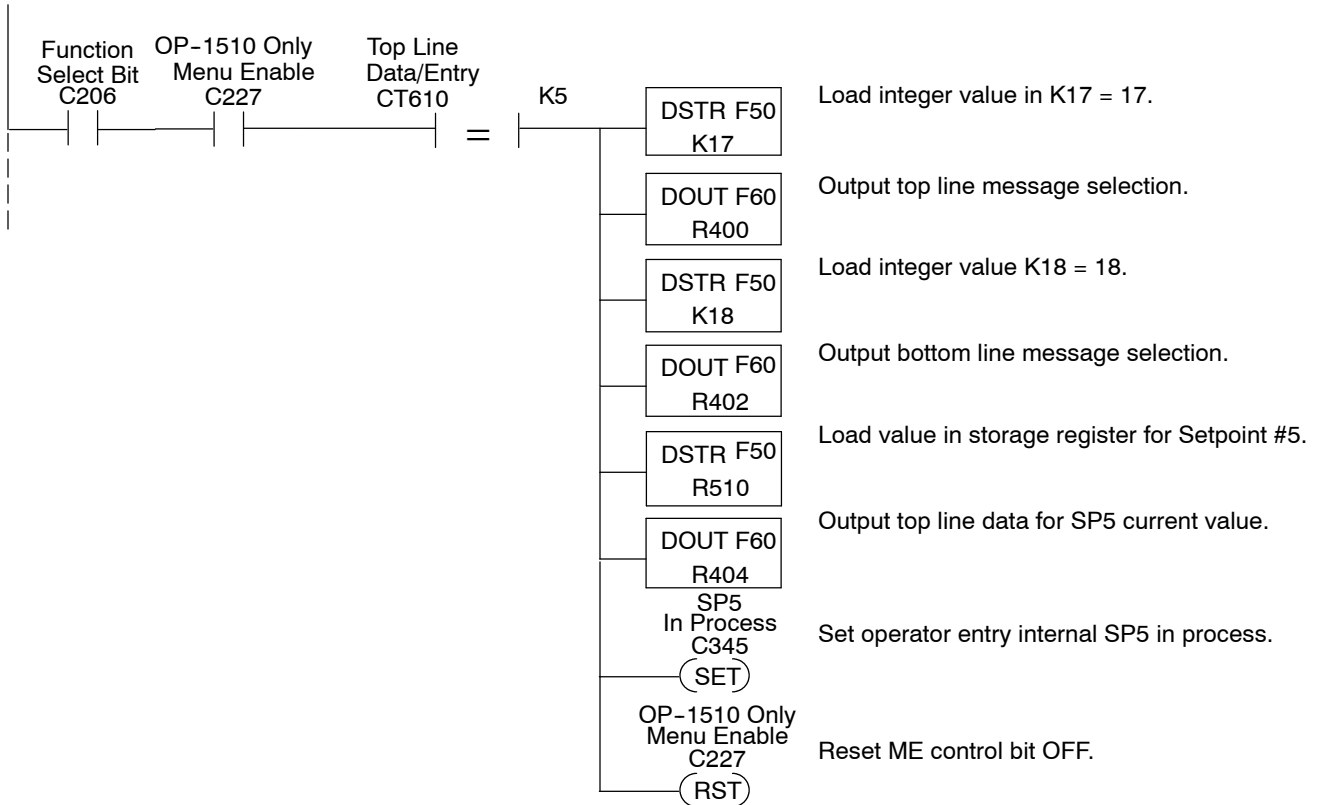

RUNG 22

Setpoint #5 Data Storage

This rung stores the keypad entry value selected for Setpoint #5 after the ENTER key is pressed and the Data Available status bit is ON.

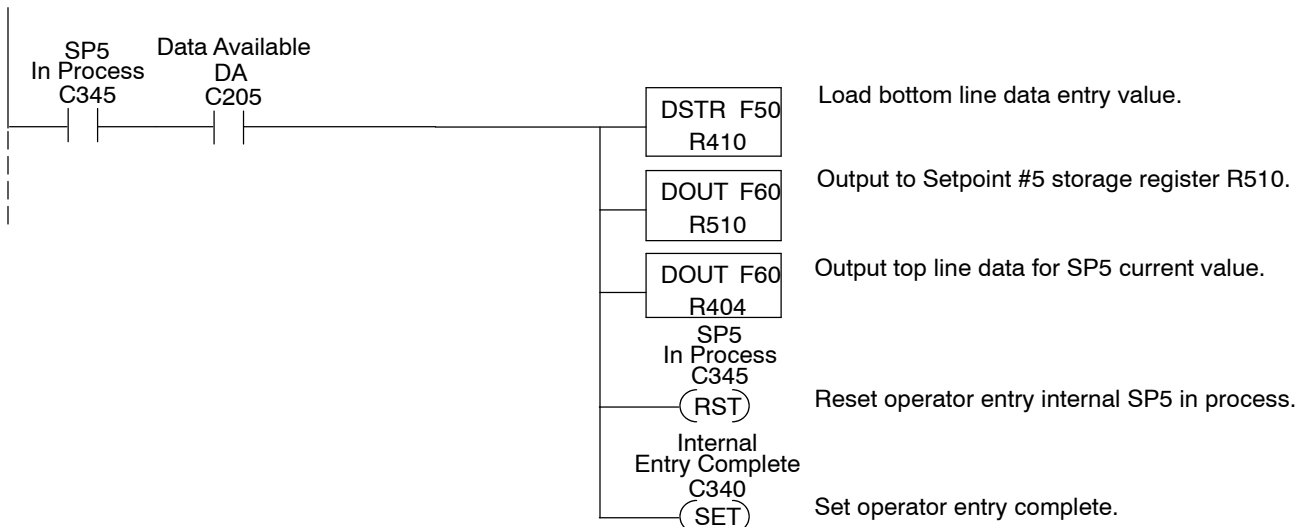

RUNG 23

Data Entry Acknowledge

This rung controls confirmation to the OP-panel that data entry and storage are complete.

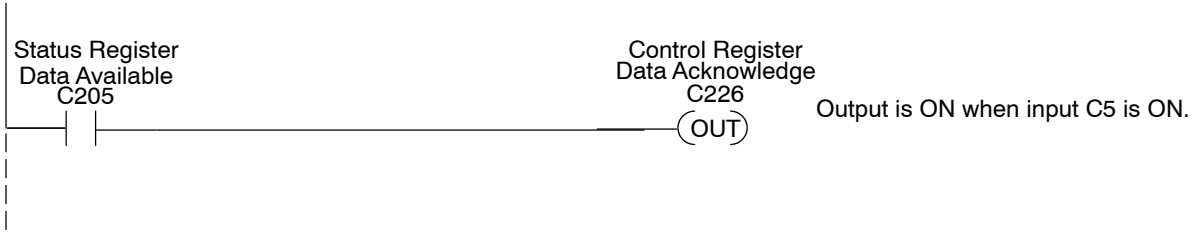

RUNG 24

Post Entry Control

This rung prepares the program for the next OP-panel operation.

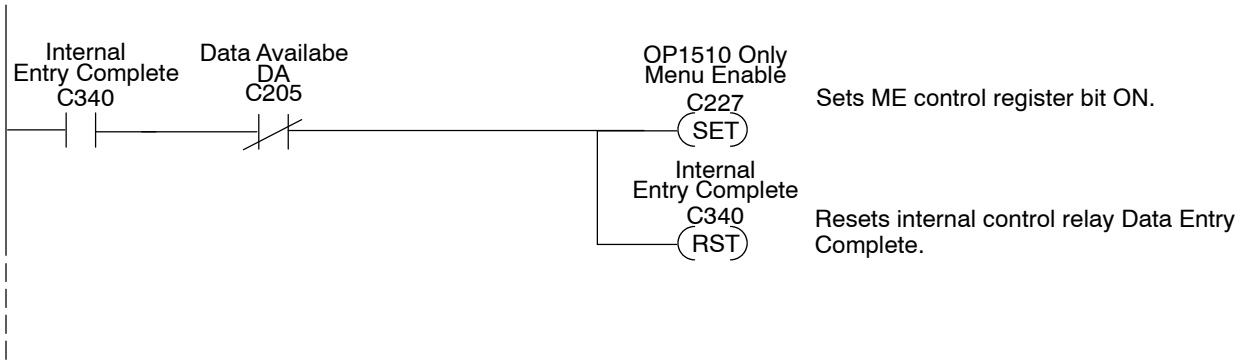

RUNG 25

Entry Mode

This rung set internal control relay for Setpoint Entry Mode interlocking.

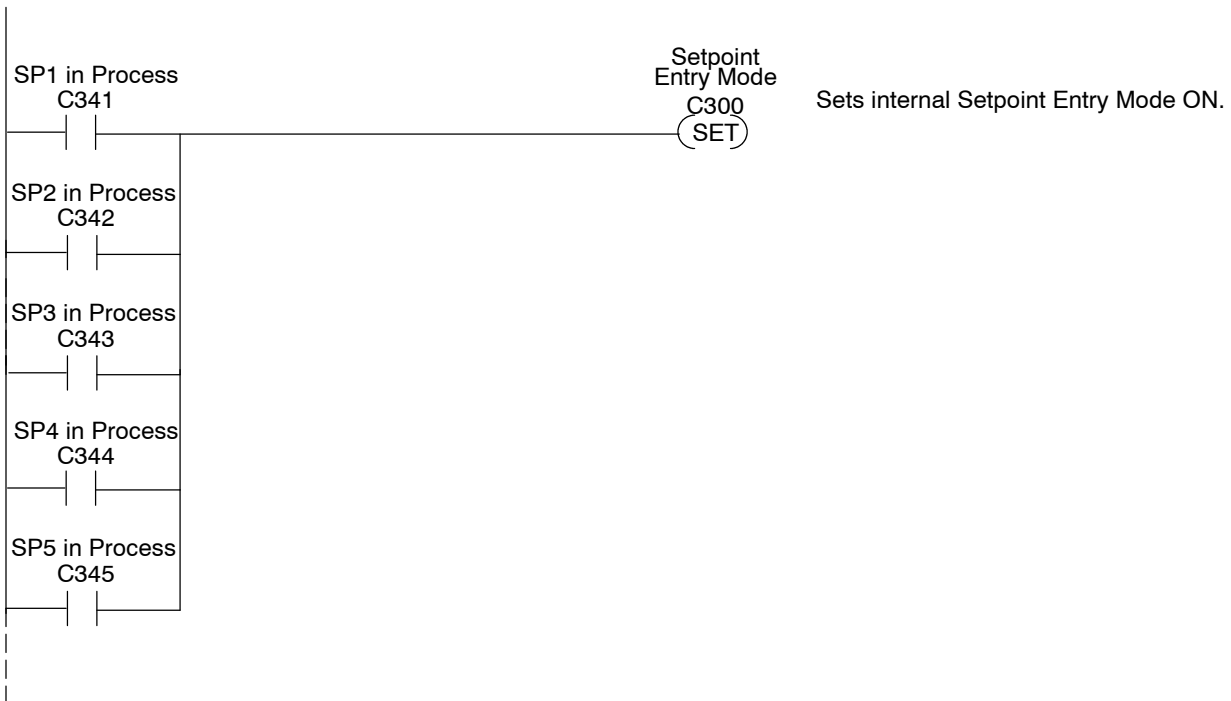

RUNG 26

Entry Mode

This rung enables the menu operation, resets setpoint in process, internal control relay for Setpoint Entry Mode interlocking.

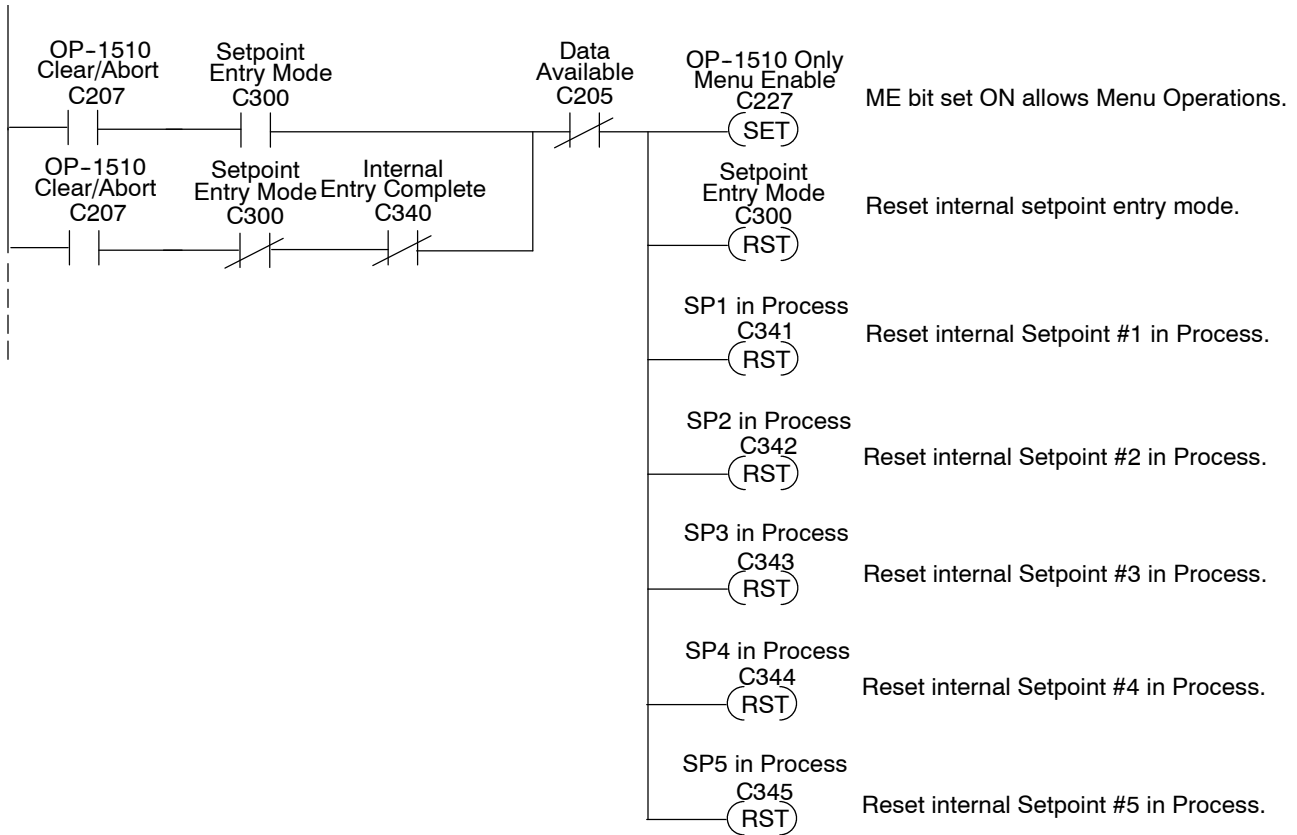

RUNG 27

End of program

This rung marks the END of program.



Appendix D

Application Examples



D

In This Appendix. . . .

— Allen-Bradley SLC 5/03 & SLC 5/04 Example

Understanding the Example Programs

The following example program uses a Cement Kiln System to demonstrate the ladder logic required to support the various OP-panel features. The program provides ladder logic which supports controlling pushbuttons, lamps, messages and menu operations.

For training purposes the example program controls the items listed in the figure below, such as Hopper Selection, Kiln Speed, Start/Stop/Run controls, and Kiln Zone Temperatures.

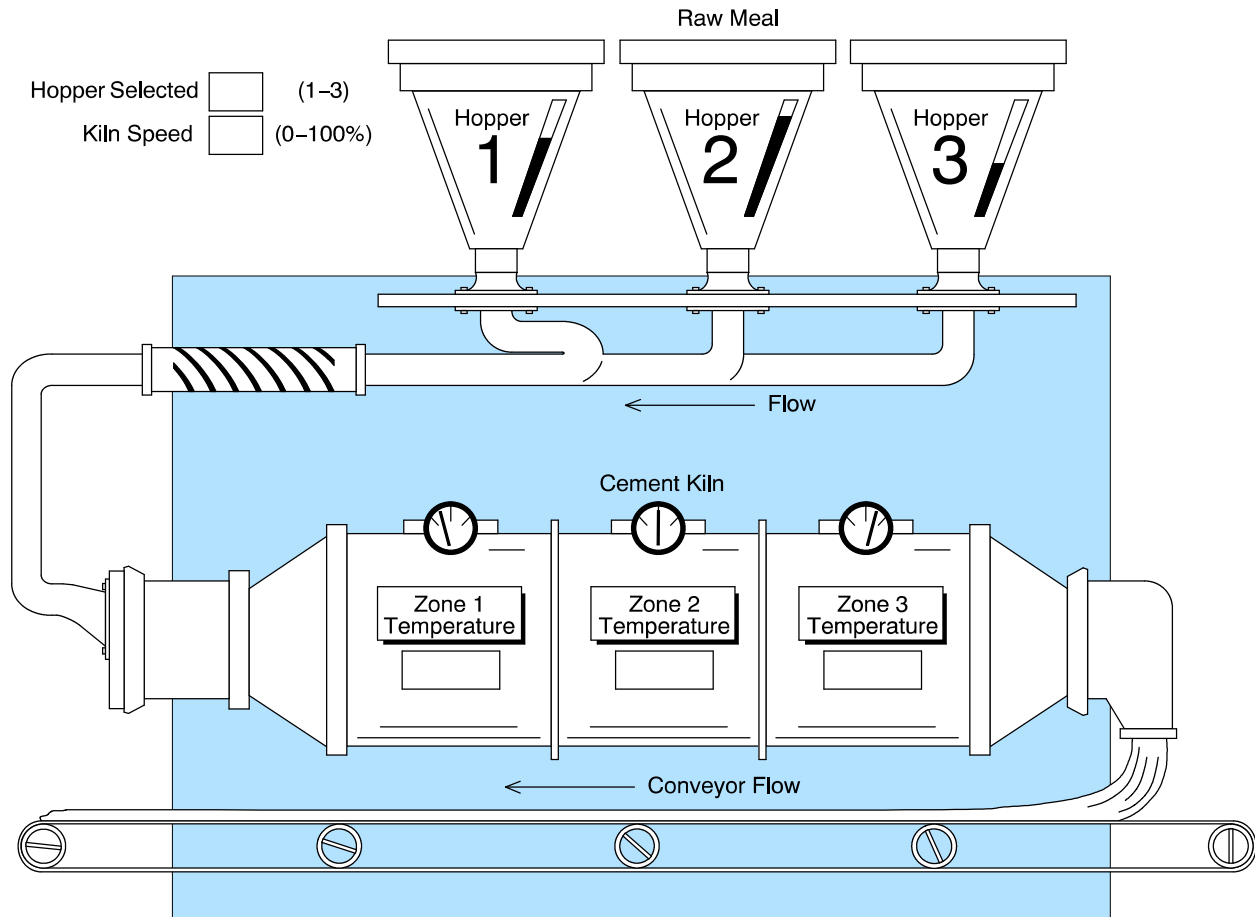

These same example programs and additional technical support information may be accessed on **PLCDirect**'s **worldwide web** site:

<http://www.plcdirect.com> (website for general info/file transfers)

You may also find these programs on our 24-hour per day **BBS** system at:

770-844-4209

If you find a problem with any of our products, services, or manuals, please fill out and return the 'Suggestions' card that was shipped with this manual.

Allen-Bradley Example Program

The example program listed on the following pages is designed for Allen-Bradley SLC 500 5/03, and 5/04 PLC systems. The program supports the OP-1510 Kiln Demo application. This program is included on the 3 1/2 disk labeled "OP-1500/OP-1510 Example Disk" which is provided with this manual.



a:\1510_AB.*

This example PLC program (1510_AB.*) must be used with the OP-1510 configuration file 1510_AB.OCF. Load these program files to the PLC and OP-panel for connection and operation of the Kiln Demo application. You may also refer to the Appendix A "Example Worksheets" to help understand how the OP-panel is configured.

OP-1510 Kiln Demo

This program is designed to be used with the Allen-Bradley SLC500 5/03 and 5/04 PLC systems. The following program is intended for training purposes and *may not* resolve all possible OP-panel applications. Some PLC programming knowledge is required to fully understand and implement the following program examples.

RUNG 1

If the CPU power cycles or machine and operator conditions are idle this rung will initialize the OP-panel and display message #1 and message #2.

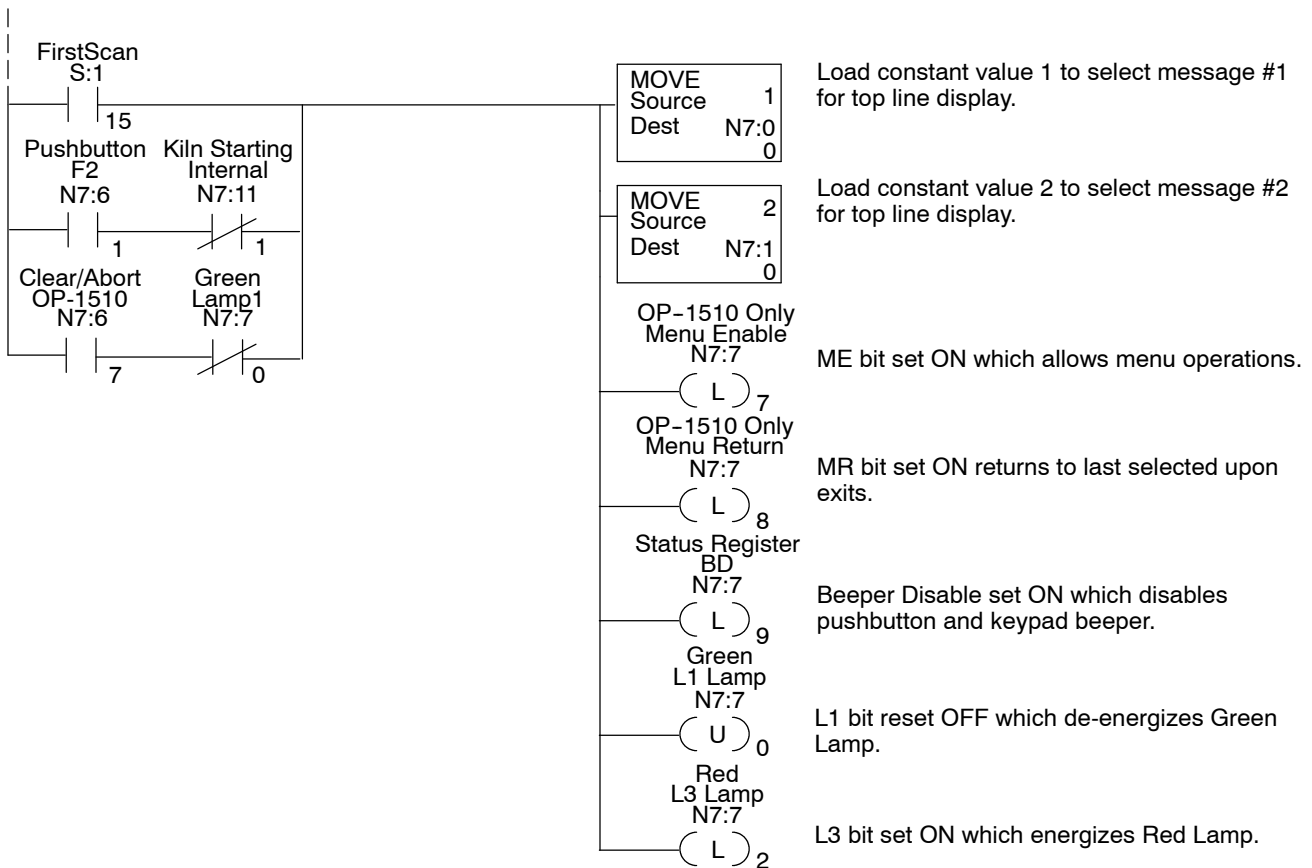

RUNG 2

Kiln Start Control

This rung controls starting a machine or process. The internal control relay Kiln Start (C51) is used to start the Startup Delay Timer, and will remain ON until the L1 control register bit is energized turn ON.

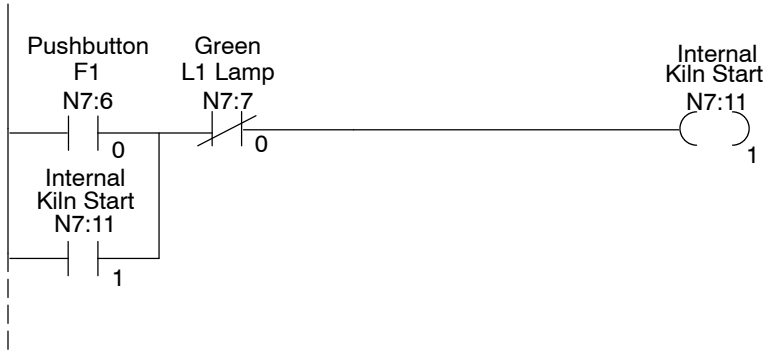

Kiln Start signal is energized (ON) if start pushbutton F1 pressed.

RUNG 3

Kiln Starting Lamp Control

This rung controls the annunciator lamps during startup mode.



Yellow Lamp (L2) set ON.

Yellow Flash (L2F) set ON.

Reset Red Lamp (L3) OFF.

RUNG 4

Startup Delay Timer

This rung is the delay timer signal for the System Start control relay.

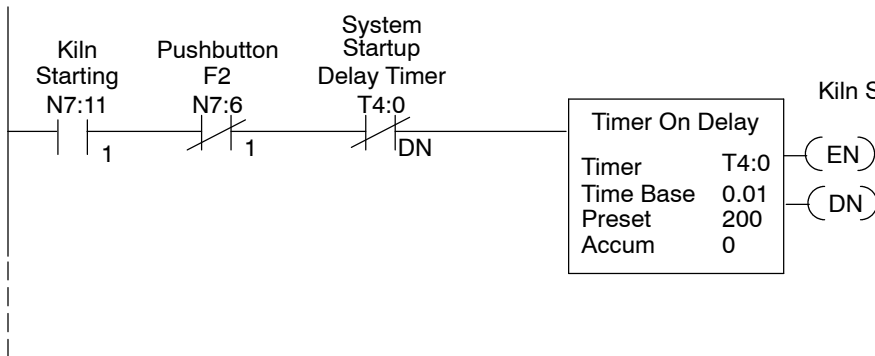

Kiln Starting input starts Delay Timer.

RUNG 5

System Running

This rung sets the internal control relay C52 System Running.

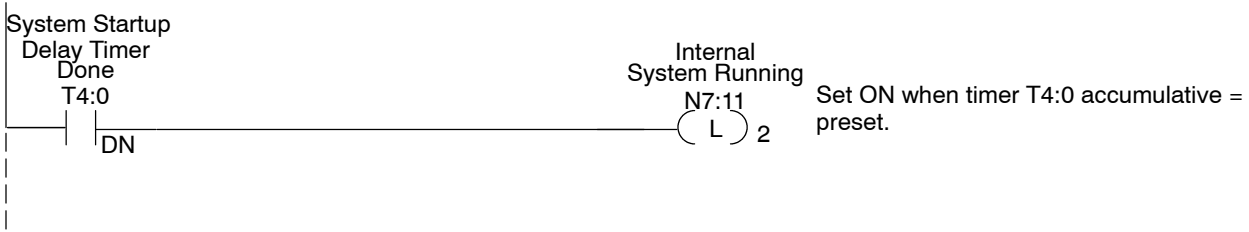

RUNG 6

System Running Lamp Control

This rung controls the annunciator lamps during startup mode.

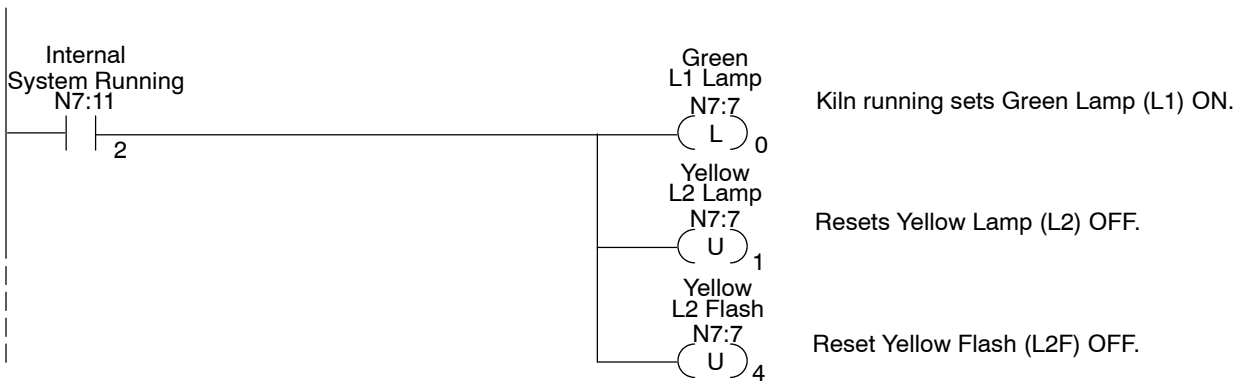

RUNG 7

This rung resets internal control relay (N7:11/2) System Running when alternating pushbutton 2 (F2) is OFF.

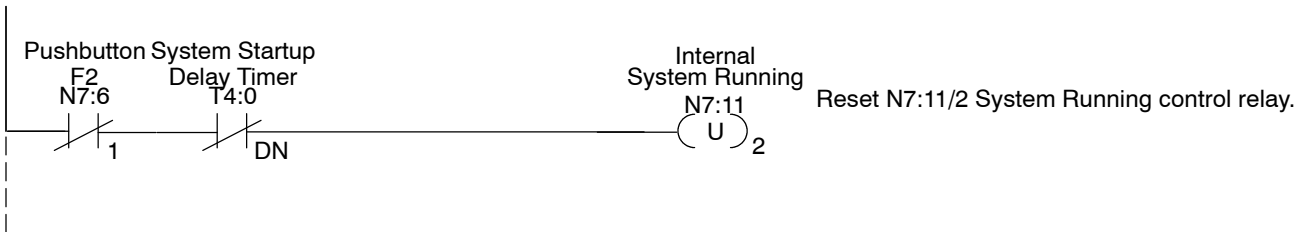

RUNG 8

Kiln Starting Message

This rung displays "Kiln Starting" message.



Load message #3 for top line display register m+0.

Load message #4 to bottom line display register m+1.

RUNG 9

System Running Message

This rung displays "System Running" message.



Load message #5 to top line display register m+0.

Load message #6 to bottom line display register m+1.

RUNG 10

Kiln System Stopped Message

This rung displays "Kiln System Stopped".

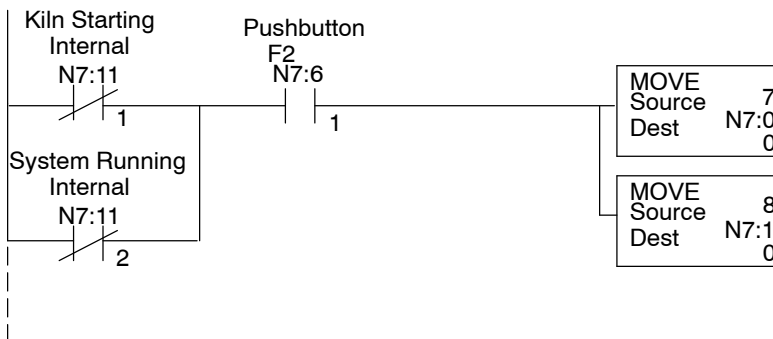

Load message #7 to top line display register m+0.

Load message #8 to bottom line display register m+1.

RUNG 11

Setpoint #1 Message Controls

This rung is executed when the Function Select Bit and Menu Enabled are ON and compare statement is equal such as menu function 1 has been selected.

The output displays the message.

“Meal Hopper (1-3):-”

“Arrow UP/DOWN =-”

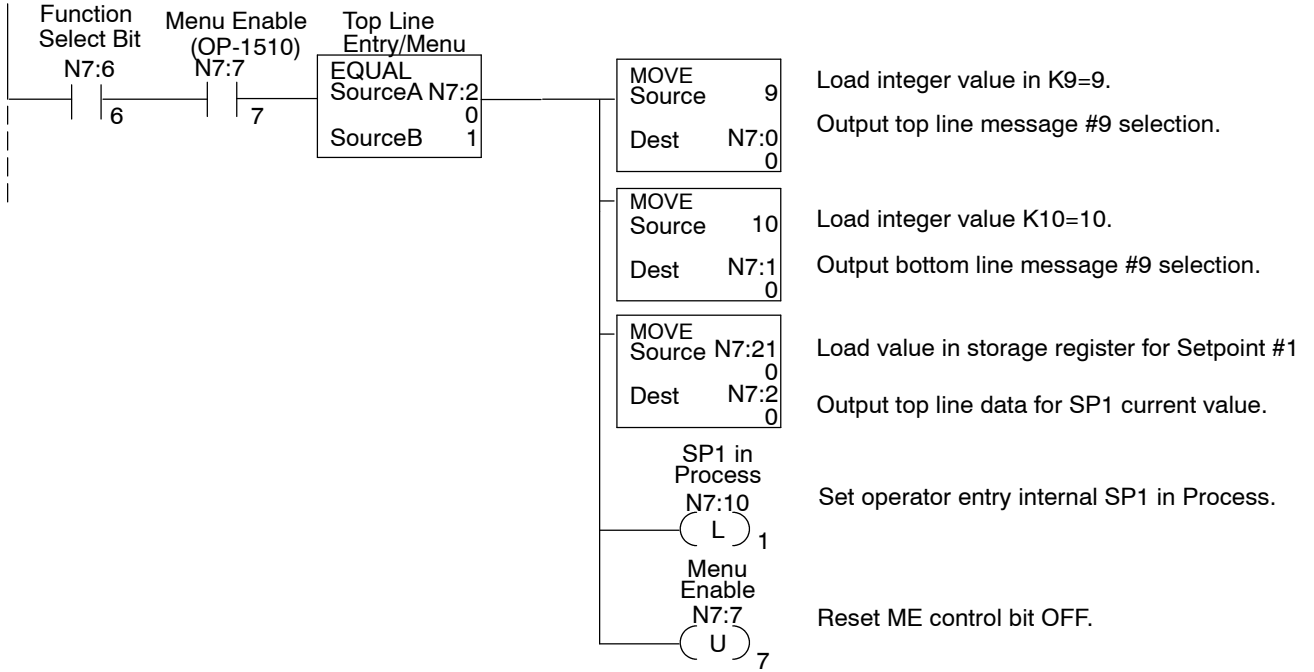

RUNG 12

Setpoint #1 Data Storage

This rung stores the up/down arrow value selected for Setpoint #1 when the ENTER key is pressed and Data Available status bit is ON.

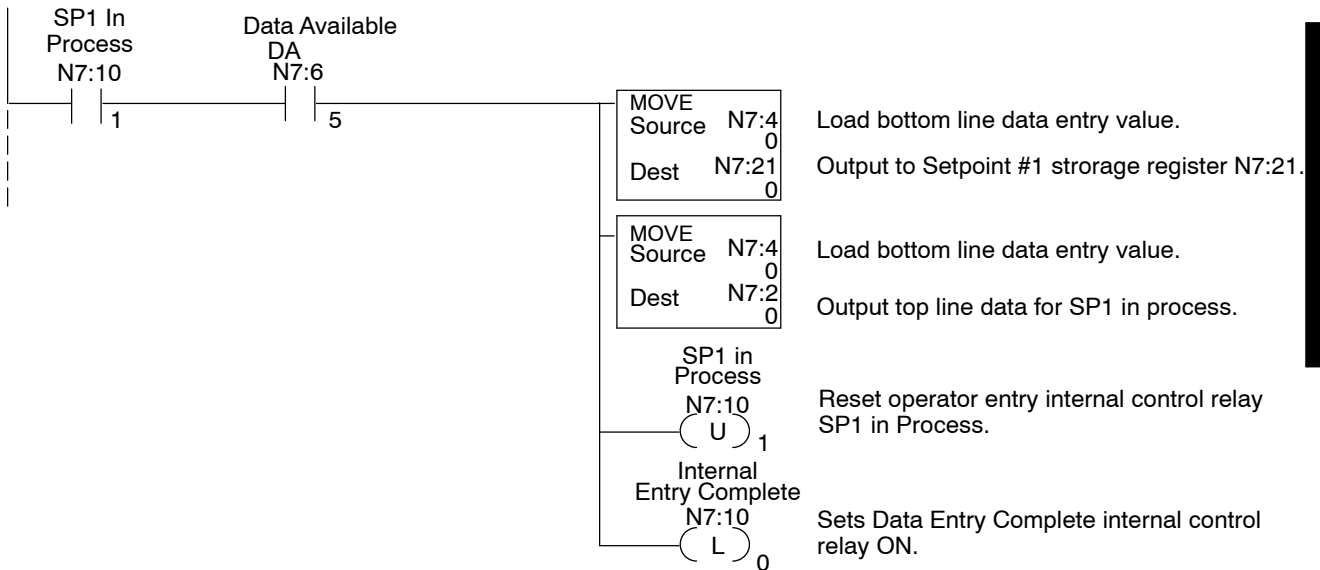

RUNG 13

Setpoint #2 Message Controls

This rung is executed when the Function Select Bit and Menu Enabled bit are ON and the compare statement is equal such as menu function 1 has been selected). The output displays the message "Kiln Speed (%): " "New Kiln Speed= "

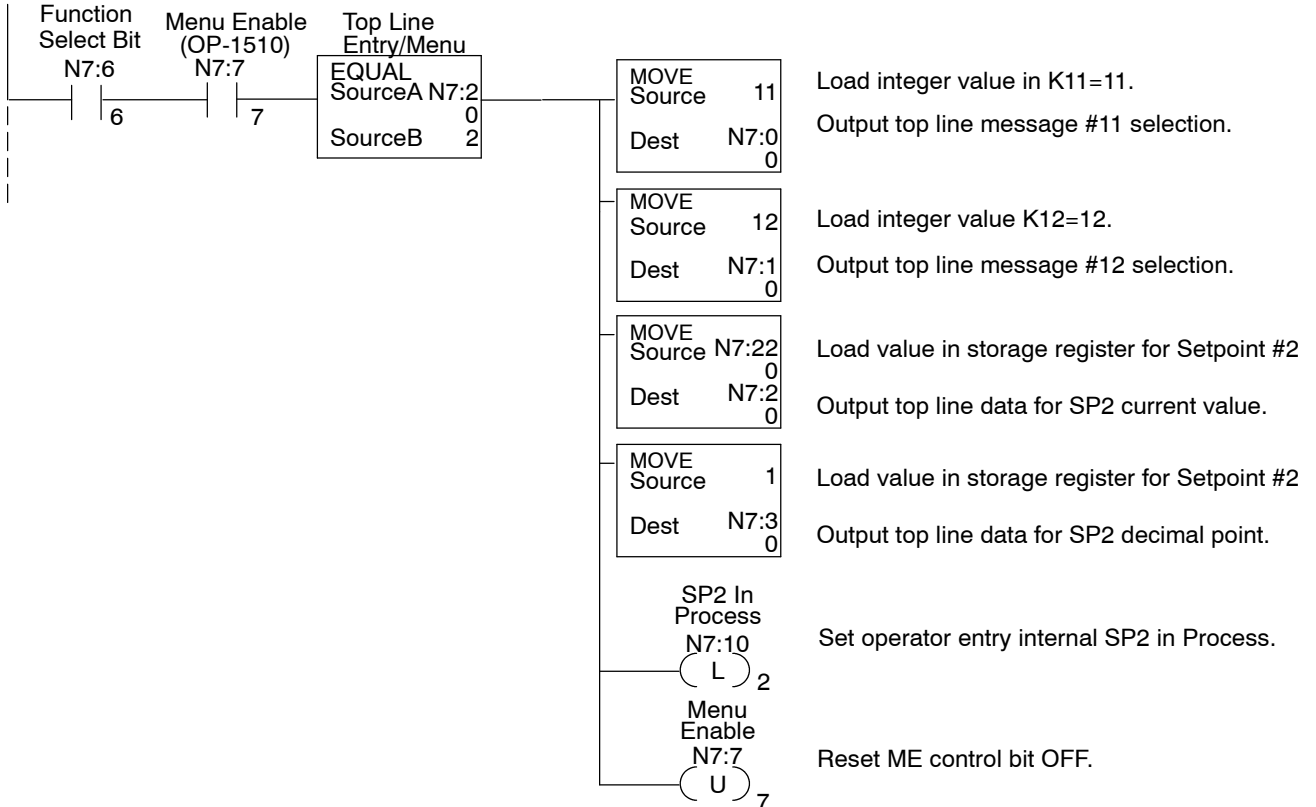

RUNG 14

Setpoint #2 Data Storage

This rung stores the keypad entry value selected for Setpoint #2 after the ENTER key is pressed and Data Available status bit is ON.

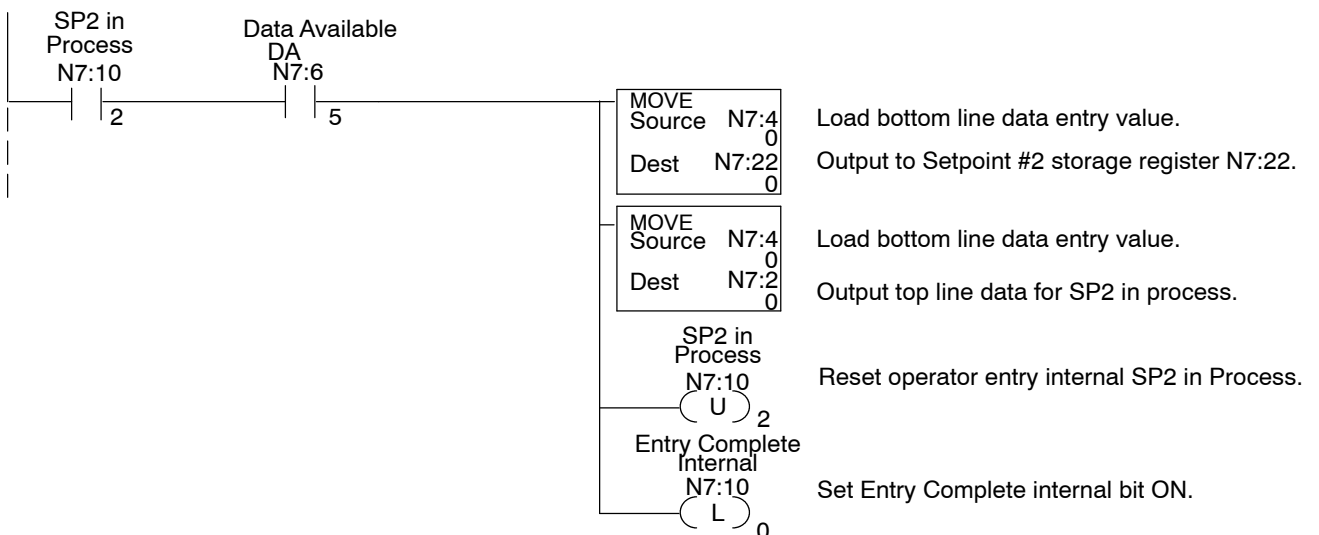

RUNG 15

Setpoint #3 Message Controls

This rung is executed when Function Select Bit and Menu Enabled BIT are ON and THE compare statement is equal such as menu function 3 has been selected.

The output displays the message "Zone1 Temp SP: " "Enter New Temp.= "

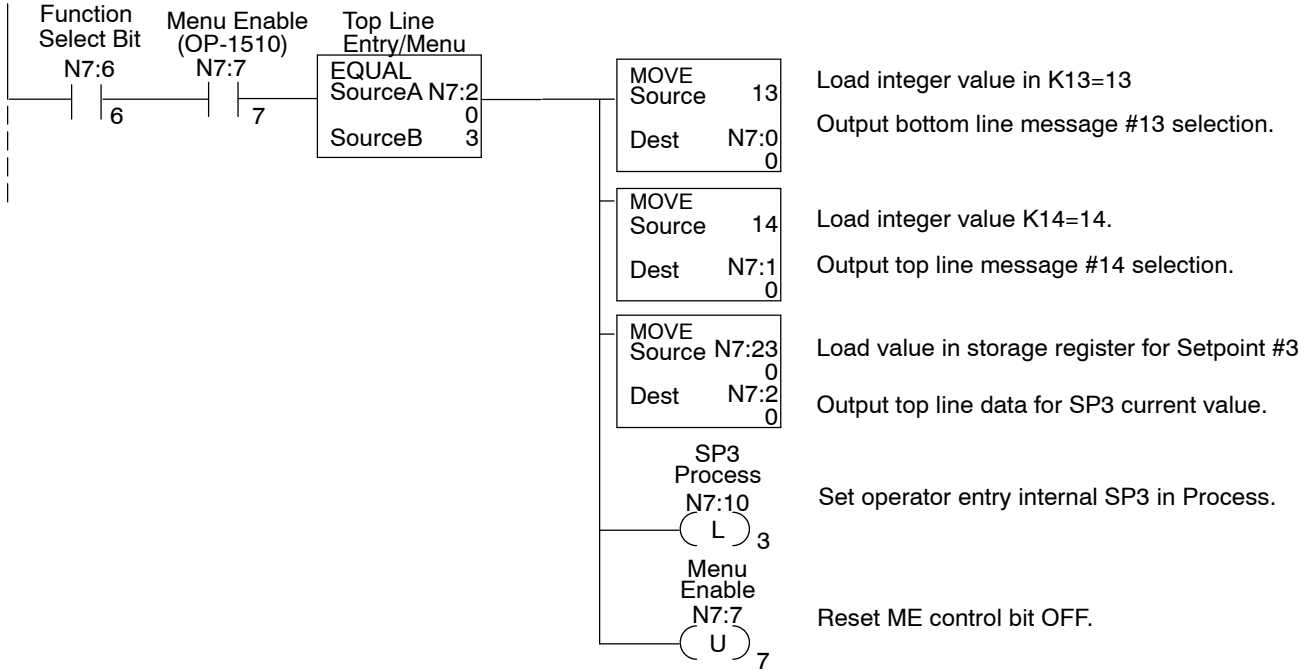

RUNG 16

Setpoint #3 Data Storage

This rung stores the keypad entry value selected for Setpoint #3 after the ENTER key is pressed and Data Available status bit is ON.

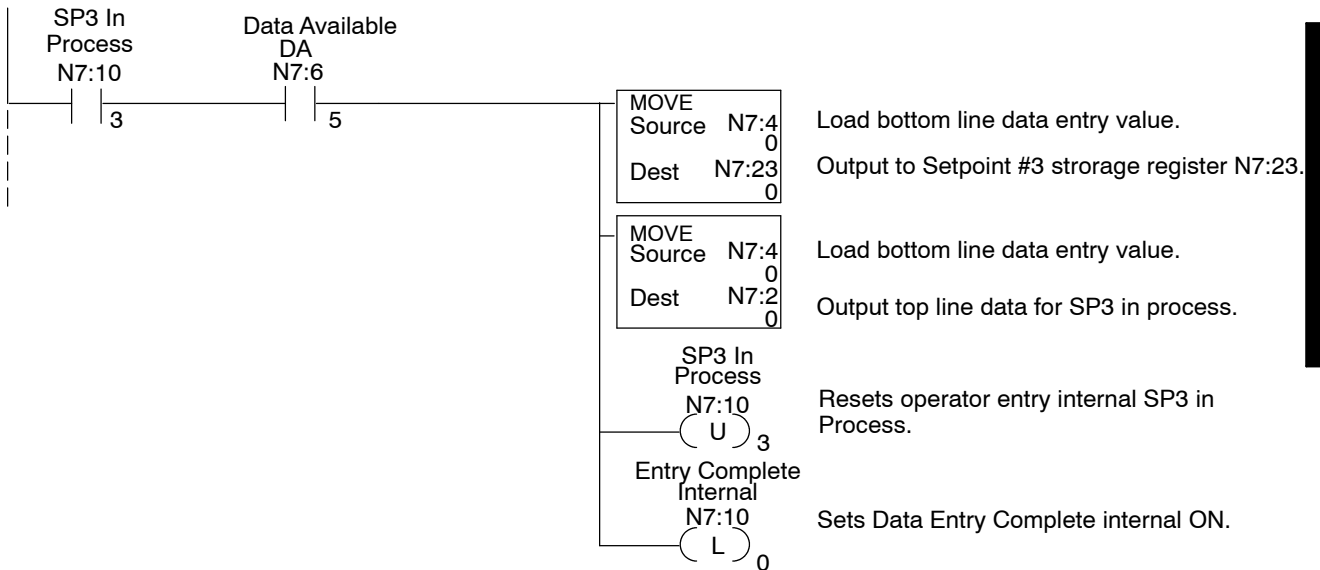

RUNG 17

Setpoint #4 Message Controls

This rung is executed when Function Select Bit and Menu Enabled bit are ON and the compare statement is equal such as menu function 4 has been selected.

The output displays the message "Zone2 Temp SP: " "Enter New Temp.= "

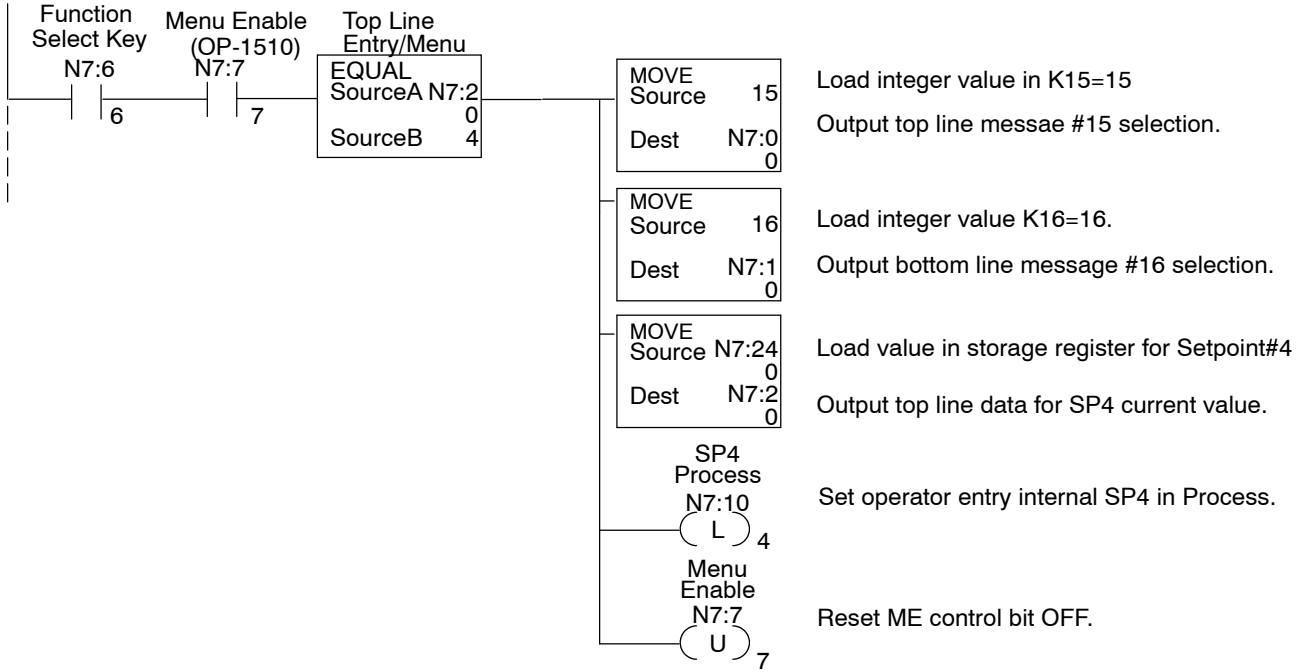

RUNG 18

Setpoint #4 Data Storage

This rung stores the keypad entry value selected for Setpoint #4 after the ENTER key is pressed and Data Available status bit is ON.

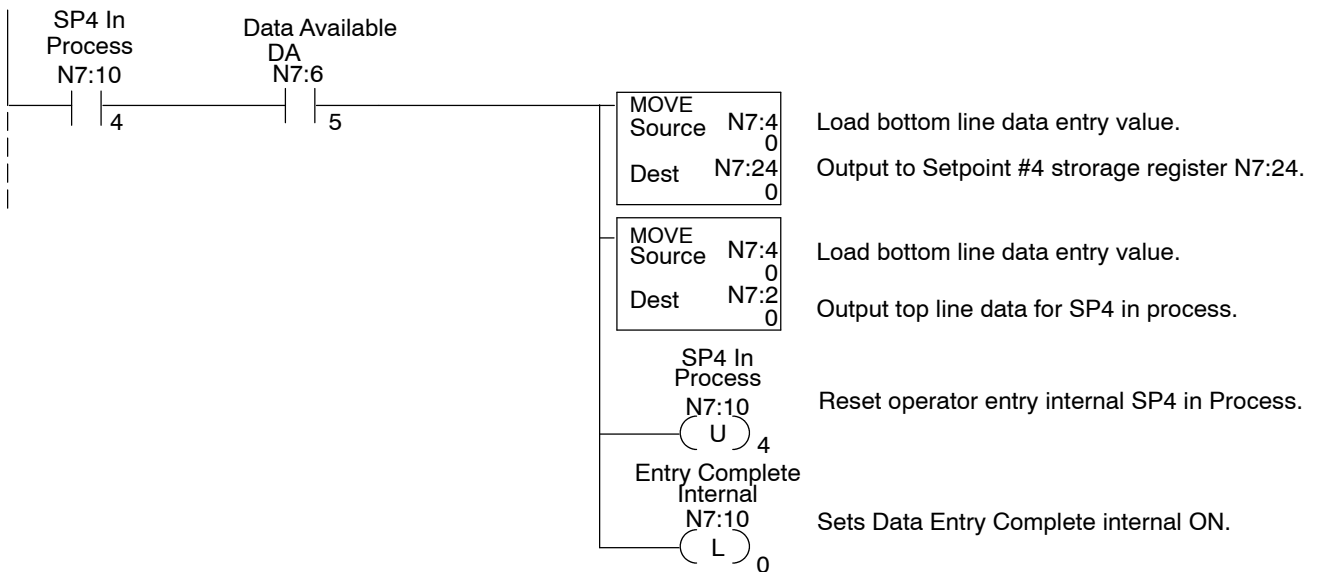

RUNG 19

Setpoint #5 Message Controls

This rung is executed when Select key and Menu Enabled bit are ON and the compare statement is equal such as menu function 5 has been selected.

The output displays the message "Zone3 Temp SP: " "Enter New Temp.= "

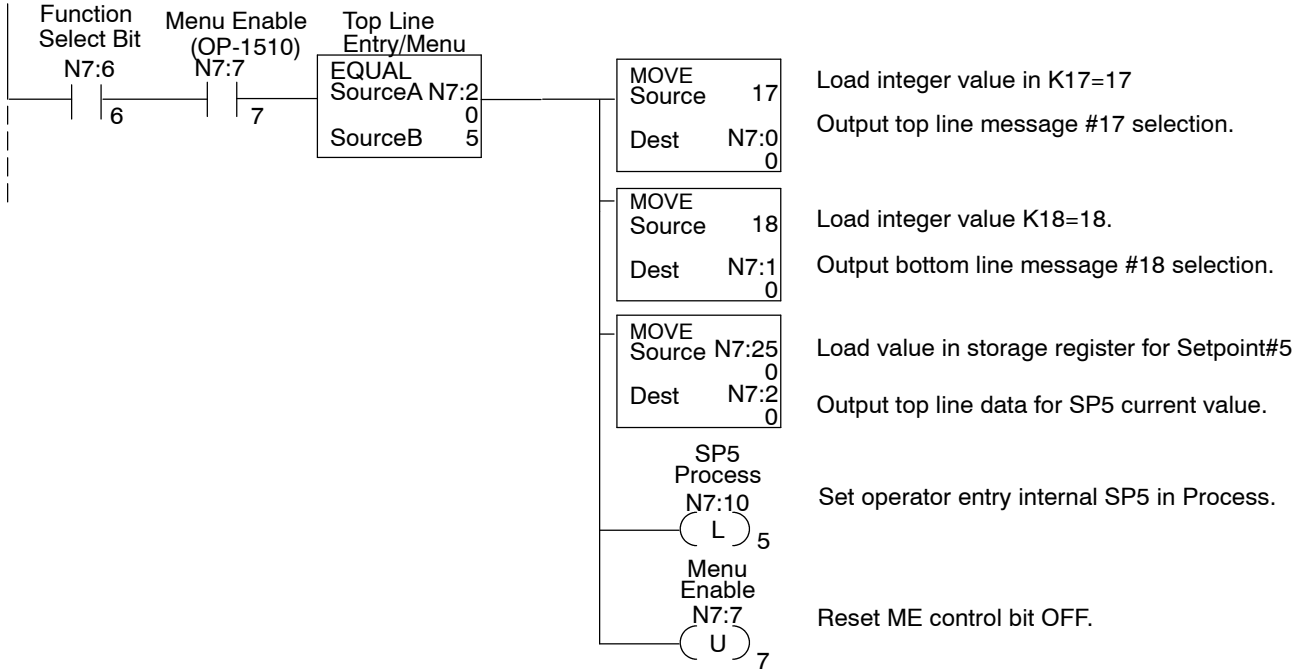

RUNG 20

Setpoint #5 Data Storage

This rung stores the keypad entry value selected for Setpoint #5 after the ENTER key is pressed and Data Available status bit is ON.

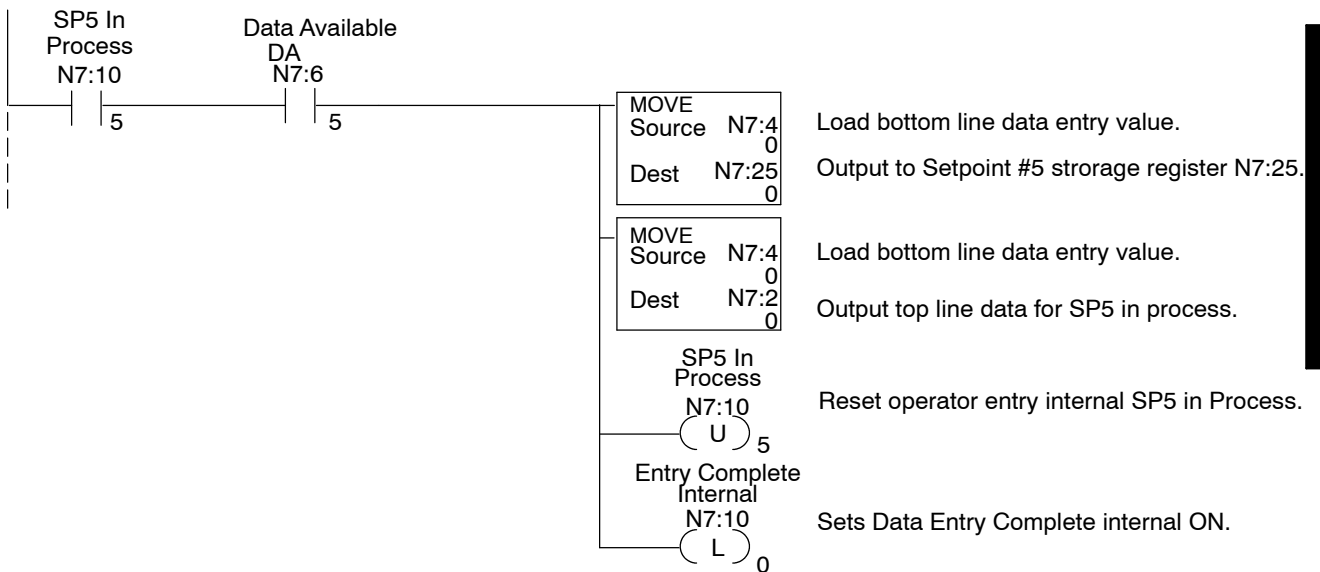

RUNG 21

Data Entry Acknowledge

This rung controls Data Acknowledge to the OP-panel indicating the PLC data entry and storage is complete.

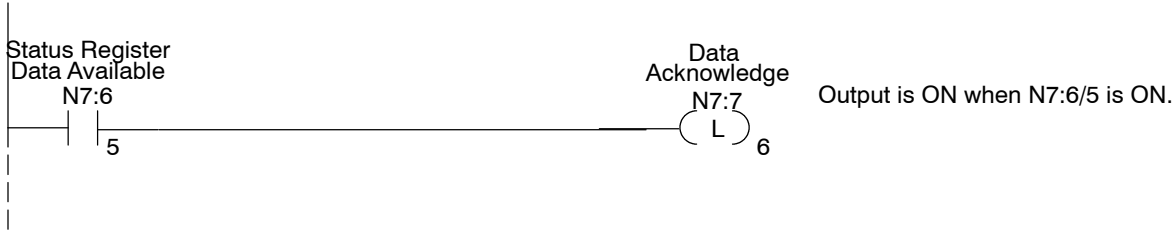

RUNG 22

Post Entry Control

This rung prepares the program for the next OP-panel operation.

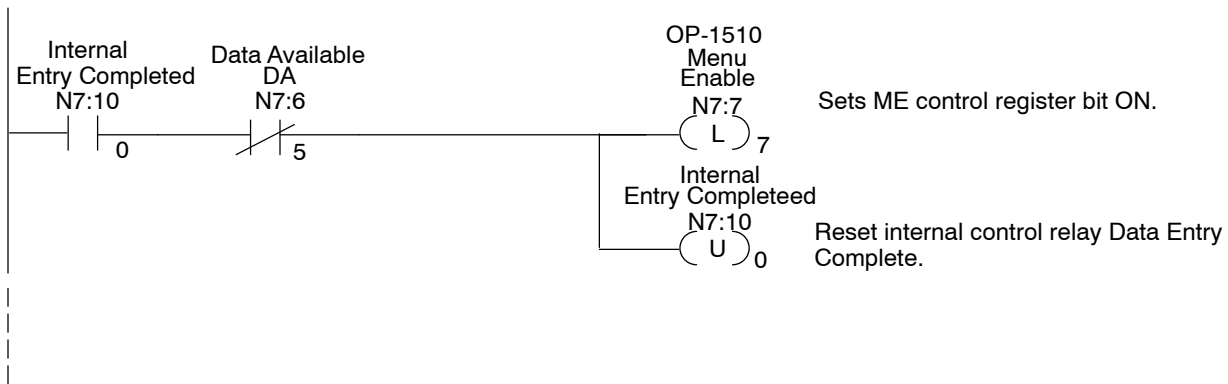

RUNG 23

Entry Mode Interlock

This rung sets internal Entry Mode which is used to interlock Entry Mode.

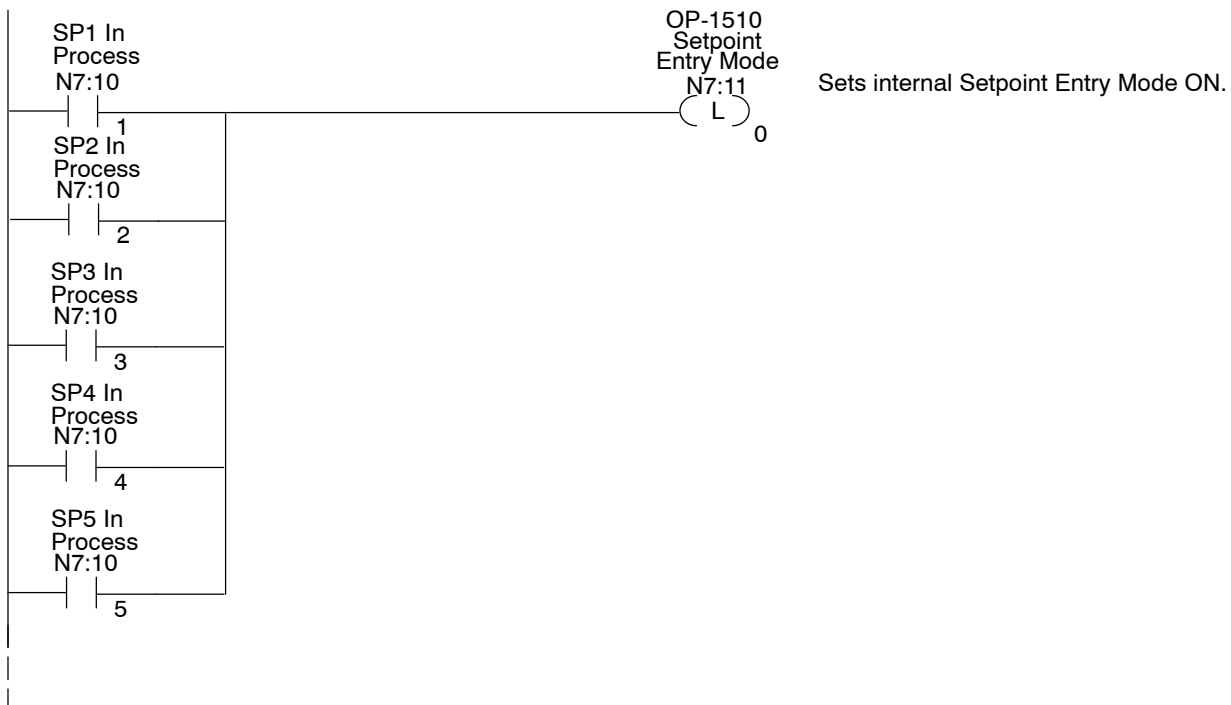

RUNG 24

Entry Mode Abort

This rung enables Menu Enable, resets Entry Mode, and Setpoint In Process control relays, which are used for OP-panel program control.

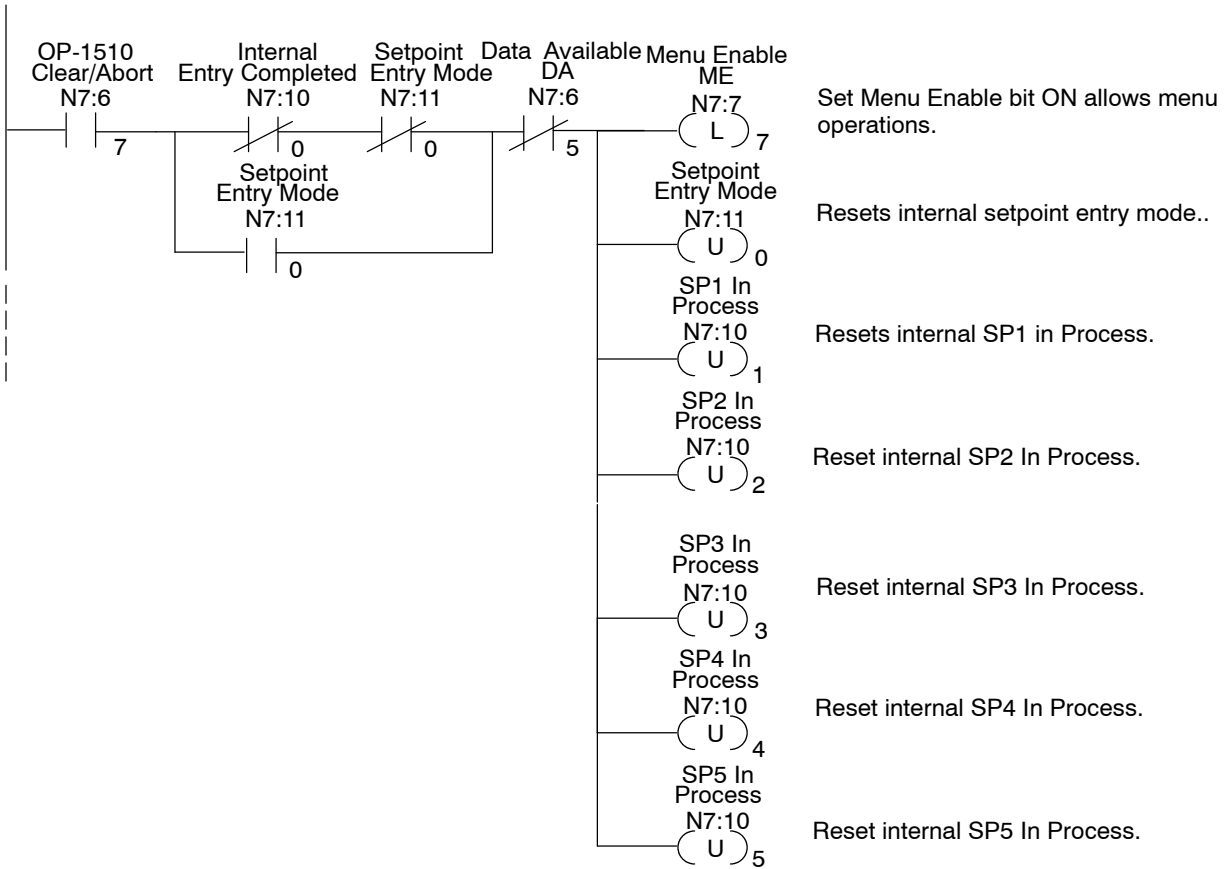

RUNG 25

End of program

This rung marks the END of program.



EU Information

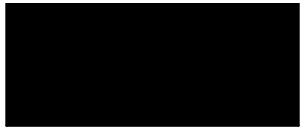

This product is manufactured in compliance with European Union (EU) Directives and carries the CE mark. The following information is provided to comply with EU documentation requirements.



NOTE: Products with CE marks perform their required functions safely and adhere to relevant standards as specified by EC directives provided they are used according to their intended purpose and that the instructions in this manual are adhered to. The protection provided by the equipment may be impaired if this equipment is used in a manner not specified in this manual. Only replacement parts supplied by **PLCDirect** or its agents should be used. A listing of international affiliates is available at our Web site <http://www.plcdirect.com>

Technical Support If you need technical assistance, please call the technical support group at **PLCDirect** (3505 Hutchinson Rd., Cumming, GA 30040, U.S.A.) at 800-633-0405. They are available Monday through Friday from 9:00 A.M. to 6:00 P.M. Eastern Standard Time. Their Web Site address is <http://www.plcdirect.com>

SELV Circuits All electrical circuits connected to the communications port receptacle are rated as Safety Extra Low Voltage (SELV).

Environmental Specifications

Operating Temperature 0° to 50° C
Storage Temperature -20° to 70° C
Operating Humidity 95% (non-condensing)
Air Composition No corrosive gases permitted

Preventative Maintenance and Cleaning No preventative maintenance is required. To clean the exterior of the panel disconnect the input power and carefully wipe the panel with a cloth moistened with plain water.

External Fuse Protection for Input Power There are no internal fuses for the input power circuits, so external circuit protection is needed to ensure the safety of service personnel and the safe operation of the equipment itself. To comply with EU specifications, the input power must be fused. Use a fuse rated at **twice** the input current rating of the panel. For example, if the panel has an input current rating of 0.5 amperes, use a fuse rated for 1 ampere.

Index

A

- Address, assignment, 2-8
- Address Block, 1-7
 - switch assignment, 2-8
 - termination resistor, 2-8
- Application, planning, 1-4

B

- Back-panel
 - access, 1-7
 - layout, 1-7

C

- Communications Cable, recommended, 2-9
- Configuration
 - address, 2-7
 - preparation, 4-2
 - software, 4-2
- Configuration Cable, 2-9
- Configuring
 - base register address, 4-6
 - communications, 4-5
 - panel address, 4-6
 - panel functions, 4-6
- Connecting Cable
 - 5/04, 2-9
 - details, 2-10
 - GE Series 1, 2-9
 - pinouts, 2-10
 - SIMATIC TI, 2-9
 - Slice I/O, 2-9
 - TI305, 2-9

- Connecting Cables, 2-9
- Connecting Cable, TI405, 2-9
- Control Register, 3-4
- CPU, cables, 2-9

D

- Data Acknowledge, control bit, 3-13
- Data Available, status bit, 3-13
- Decimal point
 - placement, 3-10
 - types, 3-10
- DirectLOGIC, communications table, 4-5
- Dynamic Message
 - bottom line display, 3-9
 - display, 3-7
 - operation, 3-7
 - top line display, 3-8

F

- Frequently Asked Questions, 1-8

I

- Interactive Message
 - arrow adjustment, 3-10
 - bottom line display, 3-12
 - numeric keypad, 3-10
 - operations, 3-10
 - status and controlbits, 3-13
 - top line display, 3-11
-

K

Keypad, entry, 1-6

L

Label

- creating, 2-3
- installation, 2-2

Lamp

- control example, 3-19
- example, 3-20
- flash example, 3-19, 3-20
- labels, 2-2
- legend, 2-3
- operation, 3-17

Legends, 2-3

M

Mapping

- control register, 3-25
- DL305 status register, 3-26
- status register, 3-24

Memory

- register assignment, 3-21
- register definition, 3-21

Memory Mapping

- compatible example, 3-25
- DirectLOGIC compatibles, 3-24
- DirectLOGIC example, 3-24
- DL305 example, 3-26
- operation, 3-24
- overview, 3-21
- PLCDirect example, 3-25

Menu

- function select bit, 3-15, 3-16
- menu bits, 3-15
- menu enable bit, 3-16
- operation, 3-5, 3-15
- planning, 3-14

Menu and Sub-Menu, 3-14

Message, display overview, 1-6

Message Display

- operations, 3-5
- types, 3-5

O

OP-9001, cable connectors, 2-9

OP-9001 Communications Master, 2-8

OP-Panel

- LCD display, 1-6
- memory definition, 3-22
- overview, 1-5
- pushbuttons, 1-5

OP-panel

- configuration mode, 2-7
- features, 3-2
- labels, 2-2
- lamps, 1-6

OPEditor

- configuration cable, 2-7
- configuration software, 4-2
- documentation, 4-3
- installation, 4-4
- system requirements, 4-3
- user steps, 4-4

P

Panel

- cutout dimensions, 2-4
- mounting dimensions, 2-4

Panel Configuration, problems, 5-2

Power Receptacle, 1-7

Power Supply

- connections, 2-6
- connectors, 2-9
- hook-up, 2-6
- requirements, 2-6

Preparing, labels, 2-2

Pushbutton

- labels, 2-2
- legend, 2-3
- operation, 3-17

R

RS-422, communications, 2-8

S

Serial Port, 1-7

Specification, storage temperature, 2-5

Specifications, 2-5

- communication link, 2-5

- diagnostics, 2-5

- environmental, 2-5

- NEMA rating, 2-5

- power connector, 2-5

Static Message

- display, 3-6

- operation, 3-6

Status and Control

- bit definition, 3-4

- bit-level access, 3-3

- register overview, 3-3

Status Register, 3-4

T

Troubleshooting, Panel to PLC communications, 5-3, 5-4

Troubleshooting, 5-2

U

User Memory, overview, 3-23
