

Mounting:

•TAP unit can be mounted to rigid pipe or as shown on reverse side if flexible tubing is used.

•Install any lubricators downstream from TAPS units.

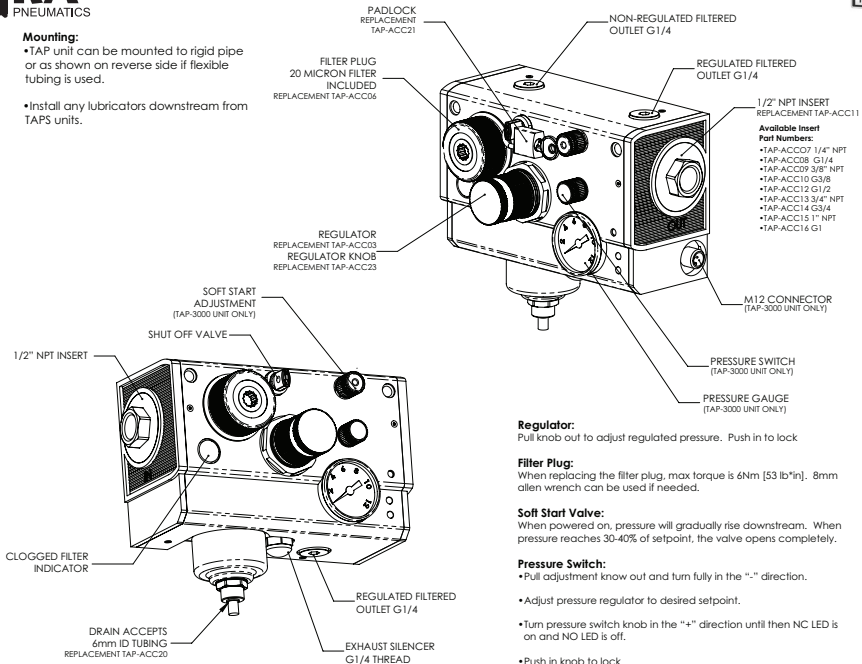

Available Insert Part Numbers:

- TAP-ACC07 1/4" NPT
- TAP-ACC08 G1/4
- TAP-ACC09 3/8" NPT
- TAP-ACC10 G3/8
- TAP-ACC12 G1/2
- TAP-ACC13 3/4" NPT
- TAP-ACC14 G3/4
- TAP-ACC15 1" NPT
- TAP-ACC16 G1

Regulator:

Pull knob out to adjust regulated pressure. Push in to lock

Filter Plug:

When replacing the filter plug, max torque is 6Nm [53 lb*in]. 8mm allen wrench can be used if needed.

Soft Start Valve:

When powered on, pressure will gradually rise downstream. When pressure reaches 30-40% of setpoint, the valve opens completely.

Pressure Switch:

- Pull adjustment knob out and turn fully in the "-" direction.
- Adjust pressure regulator to desired setpoint.
- Turn pressure switch knob in the "+" direction until then NC LED is on and NO LED is off.
- Push in knob to lock

If you have any questions concerning the installation or operation of this equipment, or if you need additional information, please call AutomationDirect.com Tech Support at 770-844-4200

MOUNTING TAP UNIT

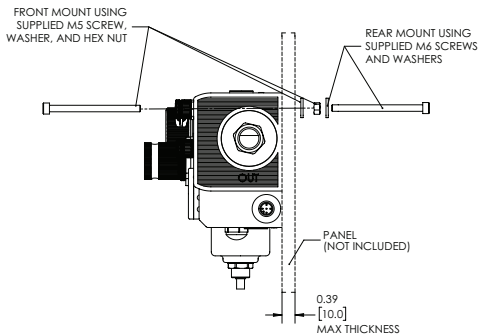

LED DESIGNATION (TAP-3000 UNIT ONLY)

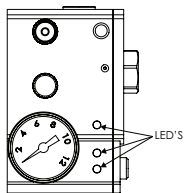

-ON: Green LED. Illuminated if the soft start or shut off valve is on.

-NC: Red LED. Illuminated if pressure is lower than pressure switch setting.

-NO: Yellow LED. Illuminated if pressure is higher than pressure switch setting.

MOUNTING TAP UNIT FLUSH WITH PANEL

