

AVTRON™ ENCODERS

Nidec Makes the Most Reliable Encoders in the World

Nidec Industrial Solutions
 243 Tuxedo Avenue | Cleveland, Ohio 44131
 encoderhelpdesk@nidec-industrial.com - www.avtronencoders.com
 +1 216-642-1230

Encoder Instructions

HS35A

1/2" to 1" [12mm-25mm]
 HOLLOW SHAFT

DESCRIPTION

The Avtron Model HS35A Hollow Shaft Rotary Incremental Encoder is a speed and position incremental transducer (also known as tachometer or rotary pulse generator). When mounted to a motor or machine, its output is directly proportional to shaft position (pulse count) or speed (pulse rate). The HS35A operates down to zero speed and can be used for both control and instrumentation applications.

The HS35A employs a hollow shaft and clamping collar to lock the encoder to the shaft. A high-performance resin hollow shaft insert provides electrical isolation from motor shaft currents and permits models to fit a broad range of shaft sizes from 1/2" to 1" [12mm - 20mm]. An anti-rotation bracket prevents rotation of the encoder while allowing for shaft end float and axial movement. An optional protective basket kit offers additional protection from impact and motor lifting damage. The HS35A encoder offers 2Ø outputs (A,B) 90° apart for direction sensing (A Quad B), with complements (A,B) and with marker pulse and complement (Z,Z)

INSTALLATION CONSIDERATIONS

See page 3 and drawing on last page for shaft engagement rules. Shaft may include keyway, but should not be flatted.

The HS35A offers optional Avtron flexible anti-rotation tethers/brackets which will permit the encoder to tolerate ±0.1" of shaft end float/axial movement. Select the proper tether for the application from the table below.

CAUTION

Be careful not to damage clamping fingers of hollow shaft during handling. Do not tighten clamping collar before installation onto motor shaft.

Equipment Needed for Installation

Provided	Optional	Not Provided
HS35A Encoder Clamping Collar	Anti-Rotation Tether Kit Shaft Sizing Insert Mating MS Cable Connector Protective Basket Kit (Part #: A32920)	#2 Phillips Screwdriver 5/32" Hex Wrench (US) 3mm Hex Wrench (Metric) (T-Handle Style) Caliper Gauge Dial Indicator Gauge 7/16", 9/16", 5/8", 3/4", 10mm Wrenches (tether options)

WARNING

Installation should be performed only by qualified personnel. Safety precautions must be taken to ensure machinery cannot rotate and all sources of power are removed during installation.

WARNING

Be certain to identify thread locker and anti-seize compound correctly. Using anti-seize in place of thread locker can cause mechanical failure leading to equipment failure, damage, and harm to operators.

HS35A PART NUMBERS AND AVAILABLE OPTIONS

Model	PPR	Line Driver	Bore Options	Connector Options	Mounting Style	Protection	Anti-Rotation Tether Options	Channels	Special Features
HS35A	G- 100 K- 200 L- 240 M- 250 E- 360 Q- 500 R- 512 S- 600 W- 1000 Y- 1024 Z- 1200 3- 2000	4- 2048 5- 2500 8- 4000 D- 4096 9- 5000 0- Special	1- 5-28V (7272) 2- 5-28V, open collector (7273) 4- 5-28V in, 5V out (7272) 0- Non-std. B- 1/2" C- 5/8" D- 3/4" E- 7/8" F- 1" P- 12mm Q- 14mm R- 15mm S- 16mm V- 19mm W- 20mm Y- 25mm U- Universal 1/2" to 7/8" (all U.S. inserts) Z- Universal 12mm to 20mm (all metric inserts)	See Table Below	U- Universal End-of-Shaft & Thru Shaft	0- None 1- Basket	X- None A- Fan cover, 1/4-20 B- Fan cover, 5/16-18 C- Fan cover, 3/8-16 D- Fan cover, all E- 4.5" or 6.75" C-Face F- 8.5" C-Face M- 4.5" C-Face or Fan Cover R- Pin and block U- Universal (all tether options)	A- A,Ā,B,Ī, Z, Z̄ B- A,Ā,B,Ī,Ī D- A,Ā E- A,B,Z F- A,B	000- None 9xx- Specify cable length xx=feet (use w/ option "W") 00W- Connector on cable

*Only available with MS 6 and 7 pin connectors

All dimensions are in inches [millimeters]. Specifications and features are subject to change without notice.

*Requires option code "00W"

Connector Options					
10 Pin MS	6 Pin MS	7 Pin MS	8 Pin M12	10 Pin Mini-twist lock*	Cable
A- w/o plug (std. phasing) B- w/o plug (Dynapar HS35 phasing) C- "A" w/ plug D- "B" w/ plug	E- w/o plug (std. phasing) F- w/o plug (Dynapar HS35 phasing) G- "E" w/ plug H- "F" w/ plug	J- w/o plug (std. phasing) K- w/o plug (Dynapar HS35 phasing) M- "J" w/ plug N- "K" w/ plug	T- w/o plug (Turck Pinout) U- w/o plug (US Pinout) 2- w/ plug (US Pinout) reverse phasing	R- 10 pin mini twist lock w/o plug (bulkhead) S- 10 pin mini twist lock on cable*	W- 18" flex. cable (std. phasing) Y- 18" flex. cable BEI wire colors (std. phasing)

INSTALLATION

Refer to the back page of these instructions for outline and mounting dimensions. Also available: EU (European Union) Installation Sheet and Basket Mount Installation Sheet.

- 1) Disconnect power from equipment and encoder cable.
- 2) Use caliper gauge to verify motor shaft is proper diameter and within allowable tolerances: +0.000", -0.0005" [+0.00, -0.013mm].
- 3) Clean machine shaft of any dirt and remove any burrs.
- 4) Use dial indicator gauge to verify the motor shaft Total Indicated Runout (TIR) < 0.002" [0.05mm].
- 5) Install the anti-rotation bracket to the face of the encoder using 8-32 screws and lock washers.
- 6) Loosen clamping collar and insert shaft sizing insert into encoder. DO NOT FORCE. The insert has a retaining flange and is larger at one end than the other.
- 7) Test Fitting: carefully slide the encoder onto the shaft to verify fit. Ensure a minimum of 1/8" between encoder and mounting surface. DO NOT FORCE. Encoder should slide on easily. If the encoder does not fit easily, remove it, verify shaft size and check for burrs and shaft damage.
- 8) Apply thread locker to screw on clamping collar. Note: models shipped since 2015 have thread locker preapplied to clamping screws. Tighten each screw to 18-20 in-lb [2.0-2.3 Nm]. DO NOT USE A STANDARD RIGHT ANGLE WRENCH. Use only a T-handle hex wrench or torque wrench with hex bit.
- 9) Secure free end of anti-rotation bracket to frame. Use insulating hardware as shown (supplied with Avtron anti-rotation kit). Use additional washers as needed to install the bracket without a large deflection or bend. For 8.5" C-Face, install 1/2"-13 to 3/8"-16 reducer with 3/8"-16 threaded stud (supplied) to secure anti-rotation bracket using insulating hardware as shown.
- 10) Turn shaft by hand and verify the shaft turns freely and does not produce excessive runout/wobble of the encoder: <0.005" [0.13mm] TIR (Total Indicator Reading). Additional instructions under "Adjusting the Encoder to Eliminate Excess Runout/Wobble" are provided if needed.
- 11) Connect cable as shown in wiring diagram.
- 12) Apply power (5-28VDC) to the encoder.
- 13) Rotate the shaft by hand, or using jog mode of the speed controller and verify proper direction.
- 14) Optional: Install Protective Basket using either T-bolts (Fan Cover) or bolt to 4.5" C-Face (bolts provided). For 8.5" C-Face use adapter clips supplied. Be certain that the Protective Basket does not touch or interfere with the anti-rotation arm. To mount the basket on an 8.5" C-face, thread the 1/2"-13 bolts into the motor face, through each clip (provided with options "F" and "U") but do not tighten fully. Pivot the basket over the encoder, and pivot each clip over each respective basket bolt hole. DO NOT FORCE. Tighten each bolt to secure the basket and clip.

Adjusting the Encoder to Eliminate Excess Runout/Wobble:

In a typical installation, a housing movement of 0.005" TIR or less (as measured at the outside diameter of the main encoder body) will not have an adverse effect. If excessive housing movement is detected in the installation:

- 1) Check the shaft the HS35A is mounted on for excessive shaft runout using a dial gauge. NEMA MG1 calls for 0.002" TIR or less.
- 2) Verify that the mounting shaft meets minimum and maximum diameter tolerances.
- 3) Maximize the shaft insertion into the encoder (retaining the minimum of 1/8" between mounting face and encoder)
- 4) Loosen the clamping collar and rotate the motor shaft 180° within the encoder hollow shaft sleeve. Retighten the clamping collar.
- 5) Loosen the clamping collar; move the split in the clamping collar over a solid portion of the encoder shaft, retighten the clamping collar.

If excessive housing movement still exists after the above steps, the shaft or the encoder may be damaged and should be checked by the manufacturer.

Shaft Sizes:

HS35A: 1/2"* , 5/8"* , 3/4"* , 7/8"* , 1"* , 12mm* , 15mm* , 16mm* , 20mm* , 25mm

NOTE:

HS35A units <1" bore utilize shaft insulating resin insert; models may be resized as needed by interchanging or removing inserts. Consult factory for other shaft sizes not shown.

Shaft Engagement:

HS35A: Shaft insertion/engagement should be 1.25" to 2.25" [32mm to 57mm] with a minimum of 0.125" [3mm] between encoder and mounting surface. Minimum insertion/engagement is 1.75" [44mm] for models using a sizing insert. If greater shaft insertion is required, remove outboard shaft cover and mount the encoder as a through-shaft unit.

For shaft lengths greater than the maximum engagement allowed, end of shaft mounting may still be employed by using a spacer between the mounting surface and anti-rotation bracket.

CAUTION

When inserting shafts to a depth over 2.25" [57mm], be sure to remove the shaft cover to prevent cover contact with the rotating shaft.

WIRING INSTRUCTIONS

CAUTION

Be sure to remove power before wiring the HS35A Encoder. Be sure to ground the cable shield(s): It can be connected to case ground at the encoder, or grounded at the receiving device, but should not be grounded on both ends. If necessary, case ground can also be provided through a separate wire. Be certain not to ground the case ground wire if the encoder is already grounded by mechanical mounting. (The standard antirotation arm kits provide insulating washers)

The HS35A encoder can be wired for single phase or two-phase operation, either with or without complements, with or without markers. See connector options and wiring diagrams.

CAUTION

When wiring for differential applications (A, \bar{A} , B, \bar{B} , Z, \bar{Z}), A and \bar{A} should be wired using one twisted, shielded pair; B and \bar{B} should be in a second pair, etc. Failure to use complementary pairs (say, using A and B in a twisted pair) will reduce noise immunity significantly.

For encoder output that correctly reflects the direction of rotation, proper phasing of the two output channels is important. Phase A channel leads phase B channel for clockwise shaft rotation as viewed from the back (non-mounting side) of the encoder for standard phasing options ("A", "C", "E", "G", "J", "M", "U", & "W"). Follow instructions under corrective installation as needed to reverse the direction of output or purchase HS35A with reverse (Dynapar HS35) phasing (options "B", "D", "F", "H", "K", & "N").

CORRECTIVE ACTION FOR PHASE REVERSAL

If Encoder Direction is Reversed:

- 1) Remove power.
- 2) Exchange wires on cable, either at encoder cable end, or at speed controller end (but not both):
 - a.) Single Ended 2 Phase Wiring (see wiring diagram below)
Exchange A and B at the user end of the wires.
 - b.) Differential 2 Phase Wiring (see wiring diagram below)
Exchange either A with \bar{A} in the phase A pair OR B with \bar{B} in the phase B pair but NOT both.

- 3) Apply power.
- 4) Verify encoder feedback is correct, using hand rotation of shaft, or jog mode of the speed controller.

Interconnecting cables specified in the wire selection chart are based on typical applications. Refer to the "Wiring Diagrams" below for suggested cable types. General electrical requirements are: stranded copper, 22 thru 16 gauge, each wire pair individually shielded with braid or foil with drain wire

* Maximum cable length (and line driver selection) is limited by several factors: line driver protection, maximum RPM, PPR, output voltage and cable capacitance. The open collector driver (option 2) is much more heavily limited by output frequency on long cable runs, and is not recommended for new applications. These factors may dictate maximum potential cable length.

SPECIFICATIONS

ELECTRICAL

- A. Operating Power (Vin)
 1. Volts.....5-28V
 2. Current.....50mA, no load
- B. Output Format.....A Quad B with marker (A, \bar{A} , B, \bar{B} , Z, \bar{Z})
- C. Signal Type.....Incremental, Square Wave, 50% \pm 10% Duty Cycle
- D. Direction Sensing.....Phasing with respect to rotation as viewed from the back of the encoder (non-clamping collar side).
Connector options "A", "C", "E", "G", "J", "M", "U", & "W": \emptyset A leads \emptyset B for CW rotation (Std. phasing).
Connector options "B", "D", "F", "H", "K", "N", & "T": \emptyset A leads \emptyset B for CCW rotation (Dynapar HS35 phasing).
- E. Transition Separation.....15% minimum
- F. Frequency Range.....0 to 125kHz.
- G. PPR.....100 - 5000 standard
- H. Output.....See Line Driver Options

MECHANICAL

- A. Acceleration.....6,000 RPM/Sec.
- B. Speed.....6,000 RPM max. (for higher RPM needs, Consult Factory).
- C. Shaft Diameter.....0.500" to 1.000" [12mm to 20mm]
- D. Shaft Engagement.....1.250" to 2.250" [32mm-57mm] End-of-Shaft*
*1.750" to 2.250" with sizing inserts
Unlimited Thru Shaft
- E. Weight.....1.6 lbs. (730g)
- F. Starting Torque @ 25C.....5oz in [0.035n-m] Max

ENVIRONMENTAL

- A. Enclosure Rating.....NEMA 4, 13, IP65 (dust and water tight, not for immersion).
- B. Operating Temp.....-20° to +100°C
- C. Humidity.....98% Non-condensing
- D. Shock.....50G, 11 ms Duration
- E. Vibration.....5-2000Hz @ 20G

LINE DRIVER OPTIONS

		Output Options		
		1	2	4
Output Type		Differential Line Driver	Open Collector	Differential Line Driver, 5V fixed
Line Driver		7272	7273	7272
Voltage Input (Vin)		5-28VDC	5-28VDC	5-28VDC
Protection	Reverse Voltage	Yes	Yes	Yes
	Transient	Yes	Yes	Yes
	Short Circuit	Yes	Yes	Yes



HS35A WIRING DIAGRAMS

LINE DRIVER (Options 1 & 4) DIFFERENTIAL TWO PHASE WIRING APPLICATIONS

		PINOUT									
CONNECTOR	OPTION "W" (CABLE)	OPTION "Y" (CABLE)	OPTION "A", "B", "C", "D" (10 PIN MS)		OPTION "J", "K", "M", "N" (7 PIN MS)	OPTION "E", "F", "G", "H" (6 PIN MS)	OPTION "T"	OPTION "U"	OPTION "S"	OPTION "R"	REF SIGNAL
CHANNELS	A	A	A	B	B	B	A	A	A	A	COM
	$\bar{O}A, \bar{O}A$ $\bar{O}B, \bar{O}B$ $\bar{O}Z, \bar{O}Z$	$\bar{O}A, \bar{O}A$ $\bar{O}B, \bar{O}B$ $\bar{O}Z, \bar{O}Z$	$\bar{O}A, \bar{O}A$ $\bar{O}B, \bar{O}B$ $\bar{O}Z, \bar{O}Z$	$\bar{O}A, \bar{O}A$ $\bar{O}B, \bar{O}B$	$\bar{O}A, \bar{O}A$ $\bar{O}B, \bar{O}B$	$\bar{O}A, \bar{O}A$ $\bar{O}B, \bar{O}B$	$\bar{O}A, \bar{O}A$ $\bar{O}B, \bar{O}B$ $\bar{O}Z, \bar{O}Z$	$\bar{O}A, \bar{O}A$ $\bar{O}B, \bar{O}B$ $\bar{O}Z, \bar{O}Z$	$\bar{O}A, \bar{O}A$ $\bar{O}B, \bar{O}B$ $\bar{O}Z, \bar{O}Z$	$\bar{O}A, \bar{O}A$ $\bar{O}B, \bar{O}B$ $\bar{O}Z, \bar{O}Z$	+V (SEE LINE DRIVER OPTIONS)
	BLACK	BLACK	F	F	F	A	1	7	F	F	
	RED	RED	D	D	D	B	2	2	D	D	
	GREEN	YELLOW	A	A	A	E	3	1	A	A	
	VIOLET	WHITE / YEL	H	C	C	C	4	3	H	H	
	BLUE	BLUE	B	B	B	D	5	4	B	B	
	BROWN	WHITE / BLU	I	E	E	F	6	5	J	J	
	ORANGE	ORANGE	C	NC	NC	NC	7	6	C	C	
	YELLOW	WHITE/ORG	J	NC	NC	NC	8	8	K	K	
	WHITE	GREEN	G	G	G	NC	NC	NC	NC	NC	CASE GND**

* NC ON CHANNEL OPTION "B"
NOTE: Connecting Case Ground is optional

TYPICAL WIRE SELECTION CHART for 18 AWG, multiple pair, individually shielded

	BELDEN	ALPHA
2 PAIR	9368	6062C
3 PAIR	9369	6063C
4 PAIR	9388	6064C
6 PAIR	9389	6066C

For Connector Option "W", unused connections must be insulated to prevent accidental contact.

HS35A WIRING DIAGRAMS

^^Open Collector Line Driver
Output Option 2 requires pull
up resistors from each active
output to a +V reference.

LINE DRIVER (Options 1,2,^ & 4) SINGLE ENDED TWO PHASE WIRING APPLICATIONS, WITH OR WITHOUT MARKER

		PINOUT									
CONNECTORS	OPTION "W" (CABLE)	OPTION "Y" (CABLE)	OPTION "A", "B", "C", "D" (10 PIN MS)	OPTION "J", "K", "M", "N" (7 PIN MS)	OPTION "E", "F", "G", "H" (6 PIN MS)	OPTION "T"	OPTION "U"	OPTION "S", "R"			
CHANNELS	A	A	E, F	E, F	E, F	A	A	A			
		ØA, ØĀ ØB, ØB̄ ØZ, ØZ̄	ØA, ØB, ØZ	ØA, ØB, ØZ	ØA, ØB, ØZ	ØA, ØĀ ØB, ØB̄ ØZ, ØZ̄	ØA, ØĀ ØB, ØB̄ ØZ, ØZ̄	ØA, ØĀ ØB, ØB̄ ØZ, ØZ̄			
		RED	D	D	B	2	2	D			
		BLUE	B	B	D	5	4	B			
		GREEN	A	A	E	3	1	A			
	BLACK	F	F	A	1	7	F				
	ORANGE	C*	C*	C*	7	6	C*				
	WHITE	GREEN	G	G	NC	NC	NC	NC			

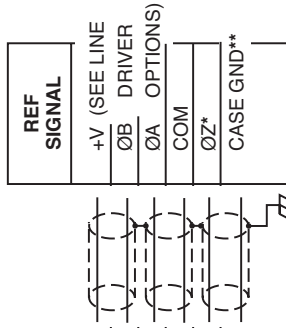

* NC: ON CHANNEL OPTION "F"
NOTE: Connecting Case Ground is optional
^ COMPLEMENTS INCLUDED BUT NOT USED

LINE DRIVER (Options 1,2,^ & 4) SINGLE ENDED SINGLE PHASE WIRING APPLICATIONS

		PINOUT									
CONNECTORS	OPTION "W" (CABLE)	OPTION "Y" (CABLE)	OPTION "A", "B", "C", "D" (10 PIN MS)	OPTION "J", "K", "M", "N" (7 PIN MS)	OPTION "E", "F", "G", "H" (6 PIN MS)	OPTION "T"	OPTION "U"	OPTION "S", "R"			
CHANNELS	A	A	D	D	D	A	A	A			
		ØA, ØB, ØB, ØZ, ØZ̄ INCLUDED BUT NOT USED)	ØA (ØĀ INCLUDED BUT NOT USED)	ØA (ØĀ INCLUDED BUT NOT USED)	ØA (ØĀ INCLUDED BUT NOT USED)	ØA, ØĀ ØB, ØB̄ ØZ, ØZ̄	ØA, ØĀ ØB, ØB̄ ØZ, ØZ̄	ØA, ØĀ ØB, ØB̄ ØZ, ØZ̄			
		BLACK	F	F	A	1	1	F			
		RED	D	D	B	2	2	D			
		GREEN	A	A	E	3	1	A			
	WHITE	GREEN	G	G	NC	NC	NC	NC			

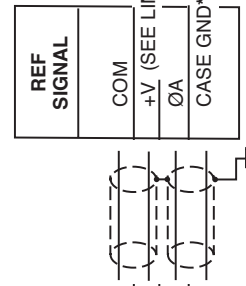

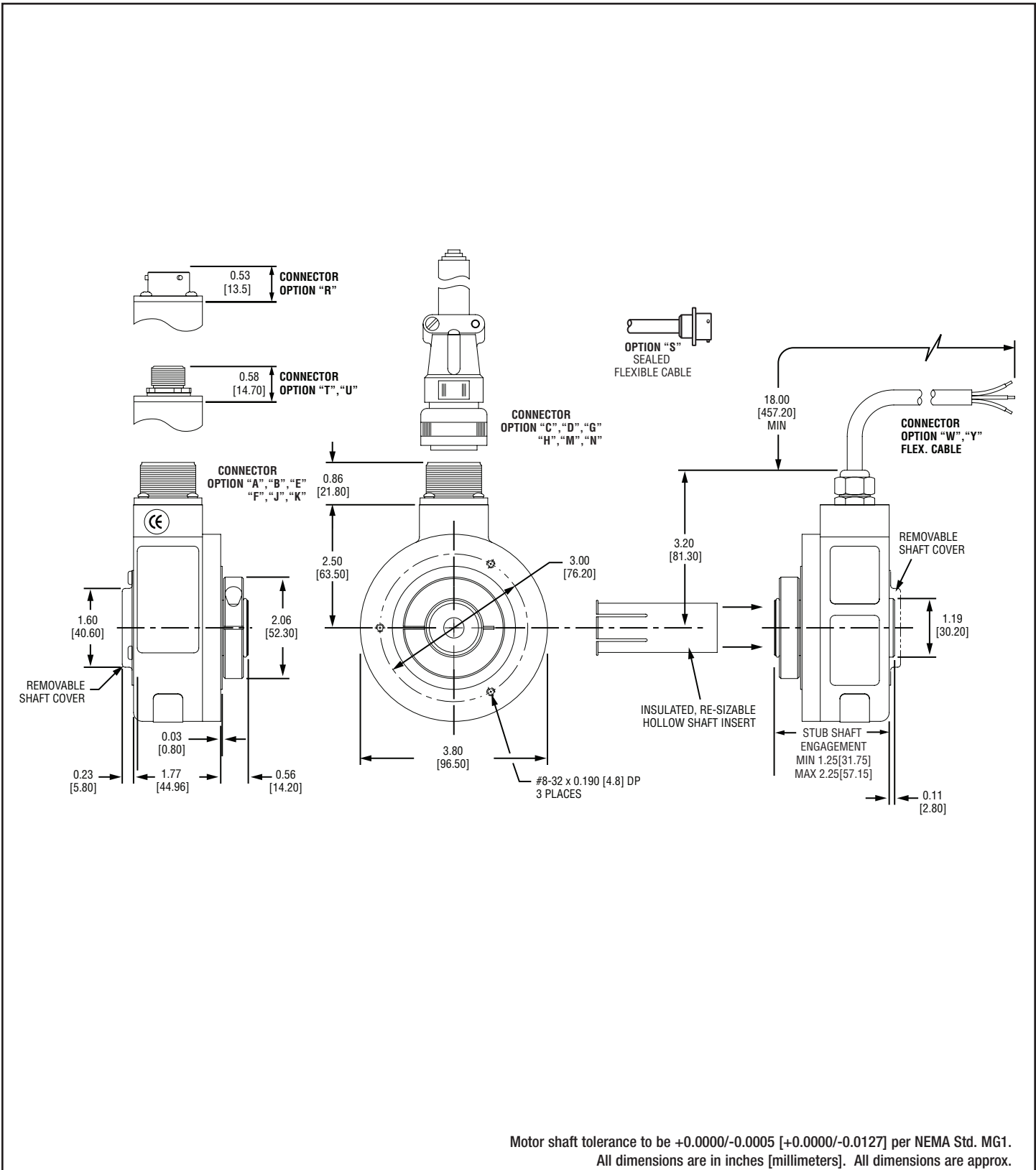

Motor shaft tolerance to be +0.0000/-0.0005 [+0.0000/-0.0127] per NEMA Std. MG1.
 All dimensions are in inches [millimeters]. All dimensions are approx.

Nidec standard warranty applies. Copies available upon request.
 Specifications subject to change without notice.



Tether/Antirotation/Protection Options

Pin & Block Tether Option "R"

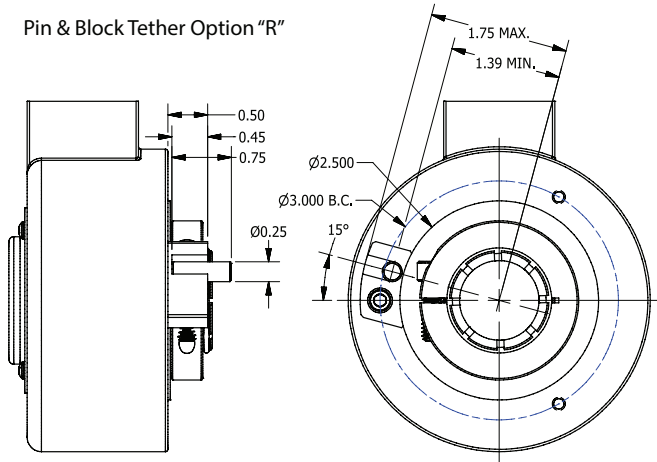

TETHER OPTION "A", "B", "C", "D", "M"

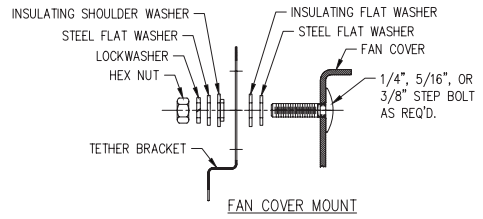

FAN COVER MOUNT

TETHER OPTION "A"

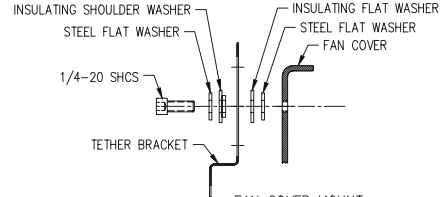

FAN COVER MOUNT WITH THREADED HOLE

TETHER OPTION "E", "M"

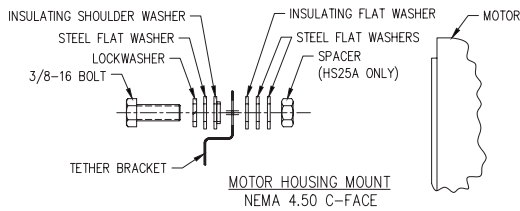

TETHER OPTION "F", "M"

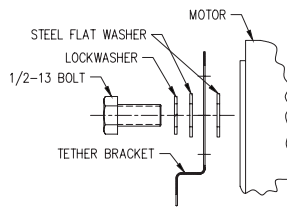

*NOTE: If encoder is positioned more than 0.13 [3.30] from motor, additional flat washers may be required to achieve a "no stress" tether position.

FAN COVER MOUNT WITH 10MM SQUARE GRILLE OPTION "1"

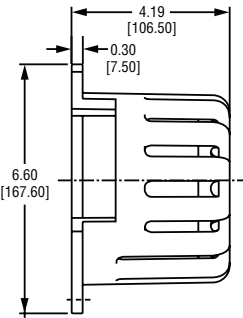
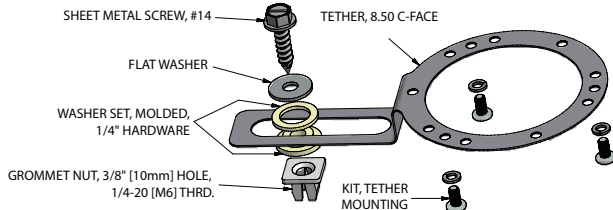

OPTIONAL PROTECTIVE BASKET GUARD

(Part#: A32920 for basket guard and all tethers)

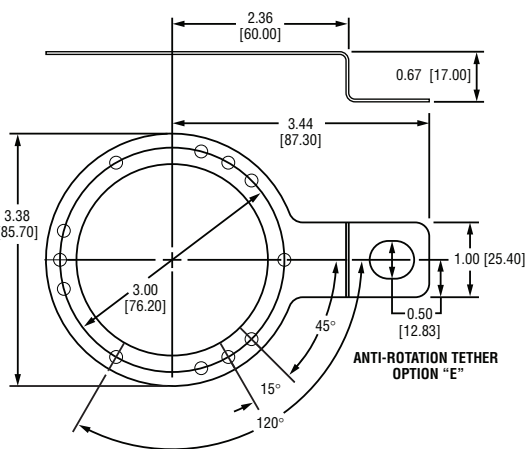

ANTI-ROTATION TETHER OPTION "E"

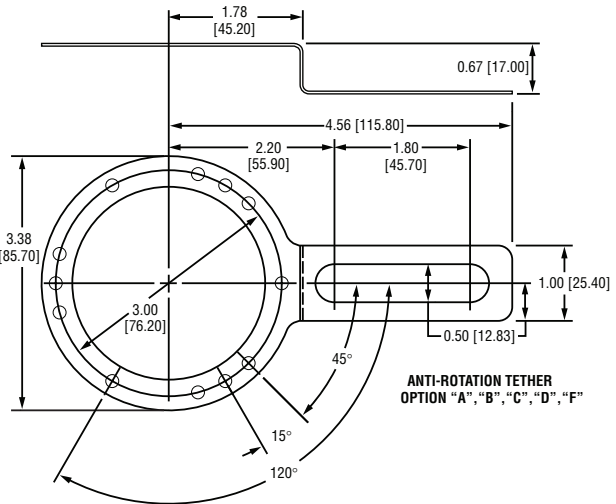

ANTI-ROTATION TETHER OPTION "A", "B", "C", "D", "F"



Nidec Makes the Most Reliable Encoders in the World

Nidec Industrial Solutions
243 Tuxedo Avenue | Cleveland, Ohio 44131
encoderhelpdesk@nidec-industrial.com - www.avtronencoders.com
+1 216-642-1230

Motor shaft tolerance to be +0.0000/-0.0005 [+0.0000/-0.0127] per NEMA Std. MG1.
All dimensions are in inches [millimeters]. All dimensions are approx.

Nidec standard warranty applies. Copies available upon request.
Specifications subject to change without notice.



REV: 09-17-2021