

# NIDEC MOTOR CORPORATION

8050 WEST FLORISSANT AVE.  
ST. LOUIS, MO 63136



**DATE:** 8/16/2023

**P.O. NO.:** CF73  
**Order/Line NO.:** 20255 MN 100

**TO:**

**Model Number:** CF73  
**Catalog Number:** UN3T2BC  
Warning  
MOD,NOTES

**REVISIONS:**  
(NONE)

**ALL DOCUMENTS HEREIN ARE CONSIDERED CERTIFIED BY NIDEC MOTOR CORPORATION.  
THANK YOU FOR YOUR ORDER AND THE OPPORTUNITY TO SERVE YOU.**

## Features:

Horsepower ..... 00003.00 ~ KW: 2.238  
Enclosure ..... TENV  
Poles ..... 04 ~ RPM: 1800  
Frame Size ..... 182~TC  
Phase/Frequency/Voltage.. 3~060~230/460 ~ Random Wound  
Service Factor ..... 1.00  
Insulation Class ..... Class "F" ~ Insulife 2000  
Altitude In Feet (Max) .. 3300 Ft.(1000 M)  
Ambient In Degree C (Max) +40 C  
Assembly Position ..... "F-1" Assembly Position  
Efficiency Class ..... Premium Efficiency  
Application ..... Unknown  
Customer Part Number ....  
Inverter Duty Rating:  
Load Type (Base Hz & Below) .. Constant Torque  
Constant HP Above Base Hz  
Speed Range (Base Hz & Below). Vector Duty (0-Base Hz)  
1:2 Above Base Hz  
"AK" Dimension (Inches).. 8.500  
Temperature Rise (Sine Wave): "F" Rise @ 1.0 SF (Resist)  
Starting Method ..... Direct-On-Line Start  
Duty Cycle ..... Continuous Duty  
Load Inertia (lb-ft<sup>2</sup>): NEMA ~ NEMA Inertia: 16.50 ~ 1.00  
Number Of Starts Per Hour: NEMA  
Motor Type Code ..... UTX  
Rotor Inertia (LB-FT<sup>2</sup>) .314 LB-FT<sup>2</sup>  
Qty. of Bearings PE (Shaft) 1  
Qty. of Bearings SE (OPP) 1  
Bearing Number PE (Shaft) 6206-2Z-J/C3  
Bearing Number SE (OPP) 6206-2Z-J/C3

Nidec trademarks followed by the ® symbol are registered with the U.S. Patent and Trademark Office.

# NIDEC MOTOR CORPORATION

8050 WEST FLORISSANT AVE.  
ST. LOUIS, MO 63136



**DATE:** 8/16/2023

**P.O. NO.:** CF73  
**Order/Line NO.:** 20255 MN 100

**TO:**

**Model Number:** CF73  
**Catalog Number:** UN3T2BC  
Warning  
MOD,NOTES

**REVISIONS:**  
(NONE)

**ALL DOCUMENTS HEREIN ARE CONSIDERED CERTIFIED BY NIDEC MOTOR CORPORATION.  
THANK YOU FOR YOUR ORDER AND THE OPPORTUNITY TO SERVE YOU.**

**Accessories:**

Special Balance  
Thermostats - Normally Closed  
Conduit Box Information: ~ Std. Oversized- Std. Const.  
Conduit Opening Size (AA) .. 3/4" NPT  
1 Conduit Opening ~ Bottom Of Conduit Box  
Standard Leadtime: REFER TO OFFICE  
Est. Weight (lbs ea): 60 ~ F.O.B.: St. Louis, MO

**USE THE DATA PROVIDED BELOW TO SELECT THE APPROPRIATE DIMENSION PRINT**

<b>Horsepower</b>	3
<b>Pole(s)</b>	04
<b>Voltage(s)</b>	460-230
<b>Frame Size</b>	182TC
<b>Shaft U Diameter</b>	1.125
<b>Outlet Box AF</b>	2.13
<b>Outlet Box AA</b>	0.75

Nidec trademarks followed by the ® symbol are registered with the U.S. Patent and Trademark Office.

EFFECTIVE:  
21-MAR-12

SUPERSEDES:  
15-JUL-08

# HORIZONTAL MOTORS

## UNIMOUNT VECTOR DUTY

FRAME: 182TC, 184TC  
TYPE: UTXN

PRINT:  
07-2693

SHEET:  
1 OF 1

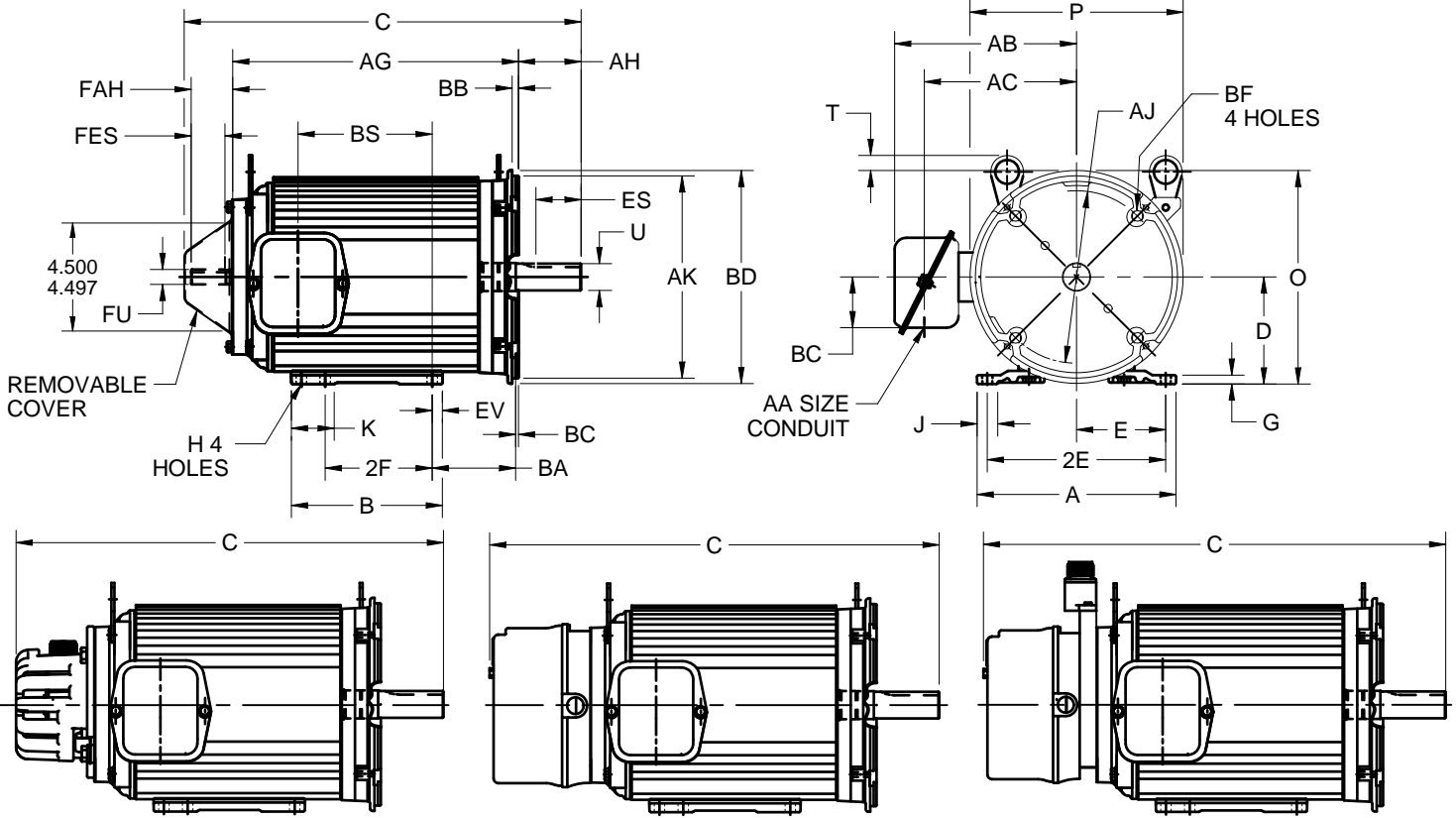

DYNAPAR ENCODER KIT ADD 1.20" TO THE 'C' DIMENSION    BRAKE ADD 2.13" TO THE 'C' DIMENSION    BRAKE WITH SL56 ADD 2.87" TO THE 'C' DIMENSION  
EPC ENCODER KIT ADD 0.76" TO THE 'C' DIMENSION    BRAKE WITH 770 ADD 3.11" TO THE 'C' DIMENSION

ALL DIMENSIONS ARE IN INCHES AND MILLIMETERS

UNITS	A	B	D -.06	E	2E ±.03	G	H +.05	J	K	O	P <sup>2</sup>	T
IN	8.38	6.38	4.50	3.75	7.50	.38	.41	.88	1.88	8.87	8.75	.63
MM	212	162	114	95	190	9	11	22	47	225	222	16

UNITS	U -.0005	AA	AB	AC	AF	AH	AJ	AK -.003	BA	BB MIN	BC	BD MAX
IN	1.1250	.75	7.75	6.31	2.13	2.62	7.250	8.500	3.50	.25	.13	9.00
MM	28.575	19	197	160	54	66	184.15	215.90	89	6	3	229

UNITS	BF <sup>4</sup>	ES MIN	EV	FAH	FES	FU -.0005	PE SQ KEY	SE SQ KEY
IN	1/2-13X.81	1.78	.44	1.75	1.50	.6250	.250	.188
MM		45	11	44	38	15.875	6.35	4.78

FRAME	HP	UNITS	C	AG	BS	2F ±.03
182TC	3	IN	15.99	11.26	4.81	4.50
		MM	406	286	122	114
184TC	5, 2	IN	16.75	12.01	5.55	5.50
		MM	425	305	141	140

TOLERANCES	
FACE RUNOUT	.004 T.I.R.
PERMISSIBLE ECCENTRICITY OF MOUNTING RABBET	.004 T.I.R.
PERMISSIBLE SHAFT RUNOUT	.002 T.I.R.

- ALL ROUGH DIMENSIONS MAY VARY BY .25" DUE TO CASTING AND/OR FABRICATION VARIATIONS.
- LARGEST MOTOR WIDTH.
- CONDUIT OPENINGS MAY BE LOCATED IN STEPS OF 90 DEGREES REGARDLESS OF LOCATION. STANDARD AS SHOWN WITH CONDUIT OPENING DOWN.

- TAP SIZE AND BOLT PENETRATION ALLOWANCE.
- ALL TAPPED HOLES ARE UNIFIED NATIONAL COARSE, RIGHT HAND THREAD.
- TOLERANCES SHOWN ARE IN INCHES ONLY.
- FRAME REFERENCE: 8.250/182/9.000/184

**Nidec Motor Corporation**  
St. Louis, Missouri

INFORMATION DISCLOSED ON THIS DOCUMENT  
IS CONSIDERED PROPRIETARY AND SHALL NOT BE  
REPRODUCED OR DISCLOSED WITHOUT WRITTEN  
CONSENT OF NIDEC MOTOR CORPORATION



ISSUED BY  
**D. MENDEZ**  
APPROVED BY  
**G. CORONADO**

IHP\_DP\_NMCA (MAR-2011) SOLIDEDGE

# NAMEPLATE DATA

CATALOG NUMBER: <input style="width: 100%;" type="text" value="UN3T2BC"/>	NAMEPLATE PART #: <input style="width: 100%;" type="text" value="422699-005"/>
MODEL <input style="width: 100%;" type="text" value="CF73"/> <input style="width: 100%;" type="text" value="FR"/> <input style="width: 100%;" type="text" value="182TC"/>	TYPE <input style="width: 100%;" type="text" value="UTNX"/> ENCL <input style="width: 100%;" type="text" value="TE"/>
SHAFT END BRG <input style="width: 100%;" type="text" value="6206-2Z-J/C3 - QTY 1"/>	OPP END BRG <input style="width: 100%;" type="text" value="6206-2Z-J/C3 - QTY 1"/>
PH <input style="width: 100%;" type="text" value="3"/> MAX AMB <input style="width: 100%;" type="text" value="40 C"/>	ID# <input style="width: 100%;" type="text"/>
INSUL CLASS <input style="width: 100%;" type="text" value="F"/> Asm. Pos. <input style="width: 100%;" type="text" value="F1"/>	DUTY <input style="width: 100%;" type="text" value="CONT"/>
HP <input style="width: 100%;" type="text" value="3"/> RPM <input style="width: 100%;" type="text" value="1770"/>	HP <input style="width: 100%;" type="text"/> RPM <input style="width: 100%;" type="text"/>
VOLTS <input style="width: 100%;" type="text" value="460"/> <input style="width: 100%;" type="text" value="230"/>	VOLTS <input style="width: 100%;" type="text"/> <input style="width: 100%;" type="text"/>
FL AMPS <input style="width: 100%;" type="text" value="5.0"/> <input style="width: 100%;" type="text" value="10.1"/>	FL AMPS <input style="width: 100%;" type="text"/> <input style="width: 100%;" type="text"/>
SF AMPS <input style="width: 100%;" type="text"/>	SF AMPS <input style="width: 100%;" type="text"/>
SF <input style="width: 100%;" type="text" value="1.00"/> DESIGN <input style="width: 100%;" type="text" value="A"/> CODE <input style="width: 100%;" type="text" value="N"/>	SF <input style="width: 100%;" type="text"/> DESIGN <input style="width: 100%;" type="text"/> CODE <input style="width: 100%;" type="text"/>
NEMA NOM EFFICIENCY <input style="width: 100%;" type="text" value="87.5"/> NOM PF <input style="width: 100%;" type="text" value="63.6"/> KiloWatt <input style="width: 100%;" type="text" value="2.238"/>	NEMA NOM EFFICIENCY <input style="width: 100%;" type="text"/> NOM PF <input style="width: 100%;" type="text"/>
GUARANTEED EFFICIENCY <input style="width: 100%;" type="text" value="85.5"/> MAX KVAR <input style="width: 100%;" type="text"/> HZ <input style="width: 100%;" type="text" value="60"/>	GUARANTEED EFFICIENCY <input style="width: 100%;" type="text"/> MAX KVAR <input style="width: 100%;" type="text"/> HZ <input style="width: 100%;" type="text"/>

**HAZARDOUS LOCATION DATA (IF APPLICABLE):**

DIVISION <input style="width: 100%;" type="text"/>	CLASS I <input style="width: 100%;" type="text"/>	GROUP I <input style="width: 100%;" type="text"/>
TEMP CODE <input style="width: 100%;" type="text"/>	CLASS II <input style="width: 100%;" type="text"/>	GROUP II <input style="width: 100%;" type="text"/>



**VFD DATA (IF APPLICABLE):**

VOLTS <input style="width: 100%;" type="text" value="460"/> <input style="width: 100%;" type="text" value="230"/>	AMPS <input style="width: 100%;" type="text" value="5.3"/> <input style="width: 100%;" type="text" value="10.6"/>
TORQUE 1 <input style="width: 100%;" type="text" value="8.9LB-FT"/>	TORQUE 2 <input style="width: 100%;" type="text" value="8.9-4.45LB-FT"/>
VFD LOAD TYPE 1 <input style="width: 100%;" type="text" value="CT/VEC"/>	VFD LOAD TYPE 2 <input style="width: 100%;" type="text" value="CHP/VEC"/>
VFD HERTZ RANGE 1 <input style="width: 100%;" type="text" value="0-60"/>	VFD HERTZ RANGE 2 <input style="width: 100%;" type="text" value="60-120"/>
VFD SPEED RANGE 1 <input style="width: 100%;" type="text" value="0-1800"/>	VFD SPEED RANGE 2 <input style="width: 100%;" type="text" value="1800-3600"/>
SERVICE FACTOR <input style="width: 100%;" type="text" value="1.00"/>	FL SLIP <input style="width: 100%;" type="text" value="30"/>
NO. POLES <input style="width: 100%;" type="text" value="4"/>	MAGNETIZING AMPS <input style="width: 100%;" type="text" value="4.0"/>
VECTOR MAX RPM <input style="width: 100%;" type="text" value="3600"/>	Encoder PPR <input style="width: 100%;" type="text"/>
Radians / Seconds <input style="width: 100%;" type="text" value="6.3"/>	Encoder Volts <input style="width: 100%;" type="text"/>

**TEAO DATA (IF APPLICABLE):**

HP (AIR OVER) <input style="width: 100%;" type="text"/>	HP (AIR OVER M/S) <input style="width: 100%;" type="text"/>	RPM (AIR OVER) <input style="width: 100%;" type="text"/>	RPM (AIR OVER M/S) <input style="width: 100%;" type="text"/>
FPM AIR VELOCITY <input style="width: 100%;" type="text"/>	FPM AIR VELOCITY M/S <input style="width: 100%;" type="text"/>	FPM AIR VELOCITY SEC <input style="width: 100%;" type="text"/>	

**ADDITIONAL NAMEPLATE DATA:**

Decal / Plate	WD=344136	Customer PN	
Notes		Non Rev Ratchet	
Max Temp Rise		OPP/Upper Oil Cap	GREASE
Thermal (WDG)	OVER TEMP PROT 2	SHAFT/Lower Oil Cap	GREASE
Altitude		Usable At	
Regulatory Notes		Regulatory Compliance	CC 030A
COS		Marine Duty	
Balance	0.08 IN/SEC	Arctic Duty	
3/4 Load Eff.	86.9	Inrush Limit	
Motor Weight (LBS)	60	Direction of Rotation	
Sound Level		Special Note 1	
Vertical Thrust (LBS)		Special Note 2	
Thrust Percentage		Special Note 3	
Bearing Life		Special Note 4	
Starting Method		Special Note 5	
Number of Starts		Special Note 6	
200/208V 60Hz Max Amps		SH Max. Temp.	
190V 50 hz Max Amps		SH Voltage	
380V 50 Hz Max Amps		SH Watts	
NEMA Inertia		Load Inertia	
Sumpheater Voltage		Sumpheater Wattage	
Special Accessory Note 1		Special Accessory Note 16	
Special Accessory Note 2		Special Accessory Note 17	
Special Accessory Note 3		Special Accessory Note 18	
Special Accessory Note 4		Special Accessory Note 19	
Special Accessory Note 5		Special Accessory Note 20	
Special Accessory Note 6		Special Accessory Note 21	
Special Accessory Note 7		Special Accessory Note 22	
Special Accessory Note 8		Special Accessory Note 23	
Special Accessory Note 9		Special Accessory Note 24	
Special Accessory Note 10		Special Accessory Note 25	
Special Accessory Note 11		Special Accessory Note 26	
Special Accessory Note 12		Special Accessory Note 27	
Special Accessory Note 13		Special Accessory Note 28	
Special Accessory Note 14		Special Accessory Note 29	
Special Accessory Note 15		Special Accessory Note 30	
Heater in C/B Voltage		Heater in C/B Watts	
Zone 2 Group		Division 2 Service Factor	
Note 1		Note 2	
Note 3		Note 4	
Note 5		Note 6	
Note 7		Note 8	
Note 9		Note 10	
Note 11		Note 12	
Note 13		Note 14	
Note 15		Note 16	
Note 17		Note 18	
Note 19		Note 20	
Note 21		Note 22	

**NIDEC MOTOR CORPORATION**  
ST. LOUIS, MO

TYPICAL NAMEPLATE DATA  
ACTUAL MOTOR NAMEPLATE LAYOUT MAY VARY  
SOME FIELDS MAY BE OMITTED



Nidec trademarks followed by the ® symbol are registered with the U.S. Patent and Trademark Office.

## MOTOR PERFORMANCE

MODEL NO.	CATALOG NO.	PHASE	TYPE	FRAME
CF73	UN3T2BC	3	UTNX	182TC
ORDER NO.		20255		LINE NO.
MPI:			147314	147315
HP:			3	3
POLES:			4	4
VOLTS:			460	230
HZ:			60	60
SERVICE FACTOR:			1	1
EFFICIENCY (%):				
S.F.				
FULL			87.5	87.5
3/4			86.9	86.9
1/2			83.7	83.7
1/4			73.9	73.9
POWER FACTOR (%):				
S.F.				
FULL			63.6	63.6
3/4			53.6	53.6
1/2			40.3	40.3
1/4			24.1	24.1
NO LOAD			5.4	5.4
LOCKED ROTOR			56.3	56.3
AMPS:				
S.F.				
FULL			5	10.1
3/4			4.5	9
1/2			4.2	8.3
1/4			3.9	7.9
NO LOAD			4	7.9
LOCKED ROTOR			46	92
NEMA CODE LETTER			N	N
NEMA DESIGN LETTER			A	A
FULL LOAD RPM			1770	1770
NEMA NOMINAL / EFFICIENCY (%)			87.5	87.5
GUARANTEED EFFICIENCY (%)			85.5	85.5
MAX KVAR			2.7	2.7
AMBIENT (°C)			40	40
ALTITUDE (FASL)			3300	3300
SAFE STALL TIME-HOT (SEC)			9	9
SOUND PRESSURE (DBA @ 1M)			0	0
TORQUES:				
BREAKDOWN{% F.L.}			573	573
LOCKED ROTOR{% F.L.}			400	400
FULL LOAD{LB-FT}			8.9	8.9

NEMA Nominal and Guaranteed Efficiencies are up to 3,300 feet above sea level and 25 ° C ambient.

The Above Data Is Typical, Sinewave Power Unless Noted Otherwise

**NIDEC MOTOR CORPORATION**  
ST. LOUIS, MO





**B109144**

### Motor Wiring Diagram 9 Lead, Dual Voltage (WYE Conn.)



To reverse direction of rotation interchange connections L1 and L2.

Each lead may have one or more cables comprising that lead.  
In such case each cable will be marked with the appropriate lead number.

THERMOSTATS

1. MOTOR IS EQUIPPED WITH QTY-3 (1 PER PHASE) NORMALLY CLOSED THERMOSTATS. THERMOSTATS ARE SET TO OPEN AT HIGH TEMPERATURE.
2. CONTACT RATINGS FOR THERMOSTATS: 120-600 VAC, 720 VA

N. C. THERMOSTATS

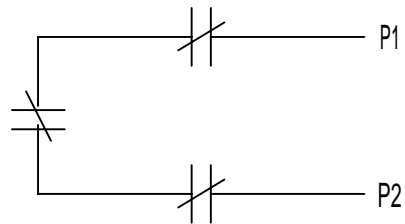

NOTE: THERMOSTATS LEADS MAY BE LOCATED IN EITHER THE MAIN OUTLET BOX OR IF SO EQUIPPED, AN AUXILIARY BOX.

ACCESSORY LISTING
QTY-3 N.C. THERMOSTATS

REVISION DESCRIPTION FOR: <b>MISC</b>		SCALE	UNITS	TITLE		NIDEC MOTOR CORPORATION		
STL0211 - UPDATED FORMAT .		<b>NONE</b>	<b>IN</b>	<b>CUSTOMER CONNECTION DIAGRAM</b>				
		TOLERANCES ON DIMENSIONS (UNLESS OTHERWISE SPECIFIED)						
MATERIAL:		<u>INCHES</u>	<u>mm</u>	ISSUED BY	APPROVED BY	REVISION DATE		
---				<b>R. KING</b>	<b>C. CADE</b>	<b>24-FEB-11</b>		
MUST BE COMPLIANT TO RoHS DIRECTIVE EU 2002/95/IEC AND REGULATION EC 1907/2006 (REACH) AS AMENDED		ANGLES X°= ±1°		CODE	DWG NO.	REV	SHEET NUMBER	DWG SIZE
					<b>0834066</b>	<b>G</b>	<b>1 OF 1</b>	<b>A</b>