

NIDEC MOTOR CORPORATION

8050 WEST FLORISSANT AVE.
ST. LOUIS, MO 63136



DATE: 8/16/2023

P.O. NO.: FD87
Order/Line NO.: 23234 MN 100

TO:

Model Number: FD87
Catalog Number: UN14T2BC
Warning
MOD,NOTES

REVISIONS:
(NONE)

**ALL DOCUMENTS HEREIN ARE CONSIDERED CERTIFIED BY NIDEC MOTOR CORPORATION.
THANK YOU FOR YOUR ORDER AND THE OPPORTUNITY TO SERVE YOU.**

Features:

Horsepower 00000.25 ~ KW: .1865
Enclosure TENV
Poles 04 ~ RPM: 1800
Frame Size 56~C
Phase/Frequency/Voltage.. 3~060~230/460 ~ Random Wound
Service Factor 1.00
Insulation Class Class "F" ~ Insulife 2000
Altitude In Feet (Max) .. 3300 Ft.(1000 M)
Ambient In Degree C (Max) +40 C
Assembly Position "F-1" Assembly Position
Efficiency Class Premium Efficiency
Application Unknown
Customer Part Number
Inverter Duty Rating:
Load Type (Base Hz & Below) .. Constant Torque
Constant HP Above Base Hz
Speed Range (Base Hz & Below). Vector Duty (0-Base Hz)
1:2 Above Base Hz
"AK" Dimension (Inches).. NA
Temperature Rise (Sine Wave): "F" Rise @ 1.0 SF (Resist)
Starting Method Direct-On-Line Start
Duty Cycle Continuous Duty
Load Inertia (lb-ft²): NEMA ~ NEMA Inertia: 1.60 ~ 1.00
Number Of Starts Per Hour: NEMA
Motor Type Code UTX
Rotor Inertia (LB-FT²) .069 LB-FT²
Qty. of Bearings PE (Shaft) 1
Qty. of Bearings SE (OPP) 1
Bearing Number PE (Shaft) 6205-2Z-J/C3
Bearing Number SE (OPP) 6203-2Z-J/C3

Nidec trademarks followed by the ® symbol are registered with the U.S. Patent and Trademark Office.

NIDEC MOTOR CORPORATION

8050 WEST FLORISSANT AVE.
ST. LOUIS, MO 63136



DATE: 8/16/2023

P.O. NO.: FD87
Order/Line NO.: 23234 MN 100

TO:

Model Number: FD87
Catalog Number: UN14T2BC
Warning
MOD,NOTES

REVISIONS:
(NONE)

**ALL DOCUMENTS HEREIN ARE CONSIDERED CERTIFIED BY NIDEC MOTOR CORPORATION.
THANK YOU FOR YOUR ORDER AND THE OPPORTUNITY TO SERVE YOU.**

Accessories:

Special Balance
Thermostats - Normally Closed
Standard Leadtime: 7-8 WEEKS
Est. Weight (lbs ea): 30 ~ F.O.B.: Monterrey, Mexico

USE THE DATA PROVIDED BELOW TO SELECT THE APPROPRIATE DIMENSION PRINT

Horsepower	.25
Pole(s)	04
Voltage(s)	460-230
Frame Size	56C
Shaft U Diameter	0.625
Outlet Box AF	1.59
Outlet Box AA	0.75

Nidec trademarks followed by the ® symbol are registered with the U.S. Patent and Trademark Office.

EFFECTIVE:
04-JUN-14

HORIZONTAL MOTORS

PRINT:
07-3116

SUPERSEDES:
04-APR-14

FRAME: 56C
BASIC TYPE: UTX

SHEET:
1 OF 2

FOR ENCODER AND BRAKE CONFIGURATIONS SEE SHEET 2

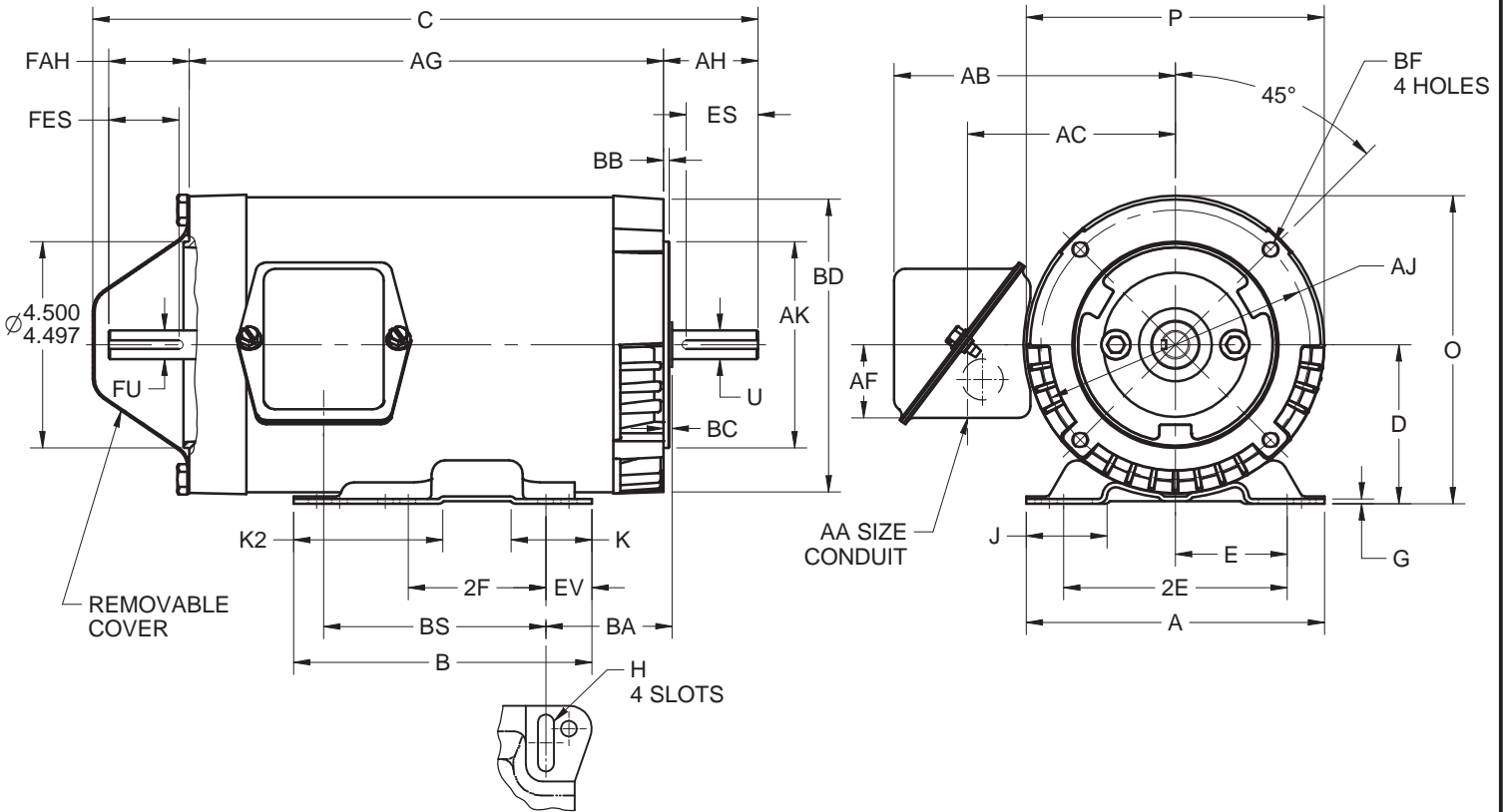

ALL DIMENSIONS ARE IN INCHES AND MILLIMETERS

UNITS	A	B	C	D -.06	E	2E ±.03	2F ±.03	G	H +.05	J	K	K2	O
IN	6.50	6.50	14.51	3.50	2.44	4.88	3.00	.13	.34 X 1.25	1.75	1.75	3.25	6.75
MM	165	165	369	89	62	124	76	3		44	44	83	171

UNITS	P ²	U -.0005	AA ⁵	AB	AC	AF	AG	AH	AJ	AK -.003	BA	BB MIN	BC
IN	6.50	.6250	.75	6.13	4.53	1.59	10.34	2.06	5.875	4.500	2.75	.13	.13
MM	165	15.875		156	115	40	263	52	149.23	114.30	70	3	3

UNITS	BD MAX	BF ^{3,4}	BS	ES MIN	EV	FAH	FES MIN	FU -.0005	DE SQ KEY	ODE SQ KEY
IN	6.50	3/8-16 X .75	4.84	1.41	1.00	1.75	1.41	.6250	.188	.188
MM	165		123	36	25	44	36	15.875	4.78	4.78

TOLERANCES	
FACE RUNOUT	.004 TIR
PERMISSIBLE ECCENTRICITY OF MOUNTING RABBET	.004 TIR
PERMISSIBLE SHAFT RUNOUT	.002 TIR

1. DIMENSIONS MAY VARY .25" DUE TO CASTING AND/OR FABRICATION VARIATIONS
2. LARGEST MOTOR WIDTH
3. ALL TAP HOLES ARE UNIFIED NATIONAL COARSE, RIGHT HAND THREAD
4. TAP SIZE AND BOLT PENETRATION ALLOWANCE
5. BASIC CONDUIT FITTING SIZE. HOLE OPENING ON THE SIDE OF THE CONDUIT BOX (REPRESENTED BY A DASHED CIRCLE) WILL ACCEPT A .50 BASIC CONDUIT FITTING
6. THE CONDUIT BOX MAY BE LOCATED ON EITHER SIDE OF THE MOTOR. THE CONDUIT OPENING(S) MAY BE LOCATED IN STEPS OF 180° REGARDLESS OF LOCATION. STANDARD LOCATION IS SHOWN WITH THE CONDUIT OPENING DOWN
7. TOLERANCES ARE SHOWN IN INCHES ONLY
8. FRAME REFERENCE; 8.00/1 AND 1.5 HP AND 9.00/2 HP

07-3116/A

Nidec Motor Corporation
St. Louis, Missouri

INFORMATION DISCLOSED ON THIS DOCUMENT IS CONSIDERED PROPRIETARY AND SHALL NOT BE REPRODUCED OR DISCLOSED WITHOUT WRITTEN CONSENT OF NIDEC MOTOR CORPORATION



ISSUED BY
R. TIMMERMANN
APPROVED BY
M. CULLEN

IHP_DP_NMCA (MAR-2011) SOLIDEDGE

EFFECTIVE:
04-JUN-14

SUPERSEDES:
04-APR-14

HORIZONTAL MOTORS
UNIMOUNT VECTOR DUTY
FRAME: 56C
BASIC TYPE: UTX

PRINT:
07-3116

SHEET:
2 OF 2

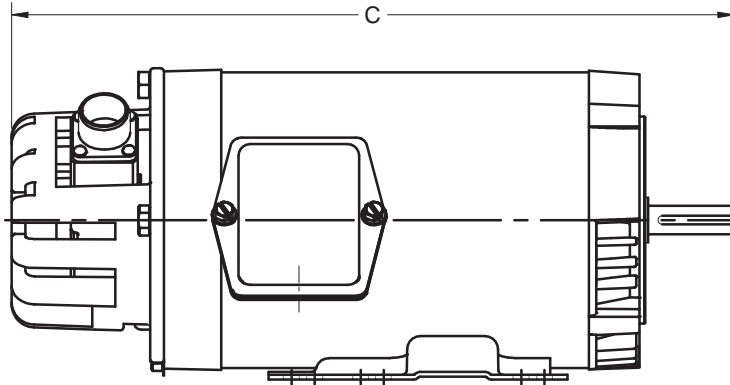

ACCOMMODATE SHAFT MOUNTED ENCODER
FOR DYNAPAR ENCODER KIT ADD 1.20" TO THE "C" DIMENSION
FOR EPC ENCODER KIT ADD .76" TO THE "C" DIMENSION

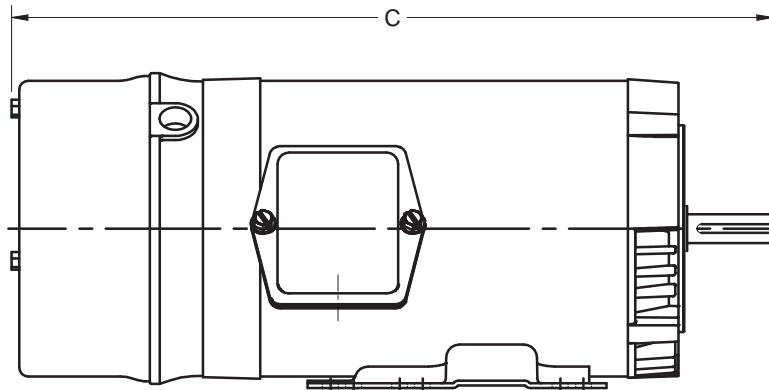

ACCOMMODATE BRAKE
FOR BRAKE ADD 2.13" TO THE "C" DIMENSION

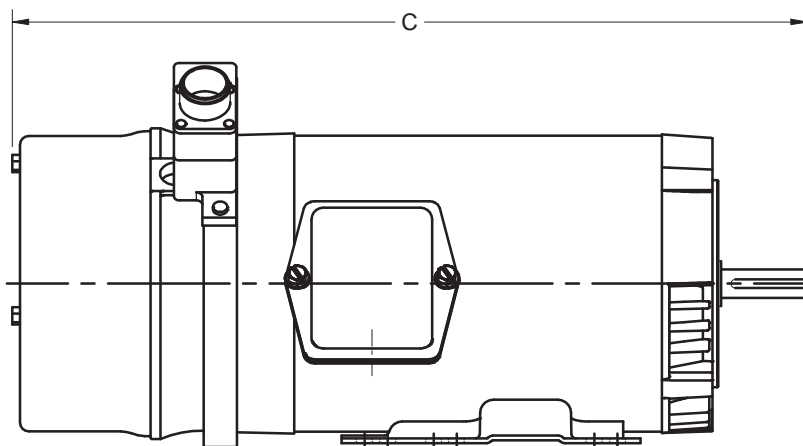

ACCOMMODATE FLANGE MOUNT ENCODER AND BRAKE
FOR BRAKE WITH SL56 ENCODER ADD 2.87" TO THE "C" DIMENSION
FOR BRAKE WITH 770 ENCODER ADD 3.11" TO THE "C" DIMENSION



NAMEPLATE DATA

CATALOG NUMBER: <input style="width: 100%;" type="text" value="UN14T2BC"/>	NAMEPLATE PART #: <input style="width: 100%;" type="text" value="422699-005"/>
MODEL <input style="width: 150px;" type="text" value="FD87"/> <input style="width: 100px;" type="text" value="FR"/> <input style="width: 100px;" type="text" value="56C"/>	TYPE <input style="width: 150px;" type="text" value="UTNX"/> ENCL <input style="width: 150px;" type="text" value="TENV"/>
SHAFT END BRG <input style="width: 100%;" type="text" value="6205-2Z-J/C3 - QTY 1"/>	OPP END BRG <input style="width: 100%;" type="text" value="6203-2Z-J/C3 - QTY 1"/>
PH <input style="width: 100px;" type="text" value="3"/> MAX AMB <input style="width: 150px;" type="text" value="40 C"/>	ID# <input style="width: 100%;" type="text"/>
INSUL CLASS <input style="width: 100px;" type="text" value="F"/> Asm. Pos. <input style="width: 150px;" type="text" value="F1"/>	DUTY <input style="width: 150px;" type="text" value="CONT"/>
HP <input style="width: 100px;" type="text" value=".25"/> <input style="width: 100px;" type="text"/> RPM <input style="width: 100px;" type="text" value="1765"/> <input style="width: 100px;" type="text"/>	HP <input style="width: 100px;" type="text"/> <input style="width: 100px;" type="text"/> RPM <input style="width: 100px;" type="text"/> <input style="width: 100px;" type="text"/>
VOLTS <input style="width: 100px;" type="text" value="460"/> <input style="width: 100px;" type="text" value="230"/> <input style="width: 100px;" type="text"/>	VOLTS <input style="width: 100px;" type="text"/> <input style="width: 100px;" type="text"/> <input style="width: 100px;" type="text"/>
FL AMPS <input style="width: 100px;" type="text" value=".5"/> <input style="width: 100px;" type="text" value="1.0"/> <input style="width: 100px;" type="text"/>	FL AMPS <input style="width: 100px;" type="text"/> <input style="width: 100px;" type="text"/> <input style="width: 100px;" type="text"/>
SF AMPS <input style="width: 100px;" type="text"/> <input style="width: 100px;" type="text"/>	SF AMPS <input style="width: 100px;" type="text"/> <input style="width: 100px;" type="text"/>
SF <input style="width: 100px;" type="text" value="1.00"/> DESIGN <input style="width: 100px;" type="text" value="A"/> CODE <input style="width: 100px;" type="text" value="P"/>	SF <input style="width: 100px;" type="text"/> DESIGN <input style="width: 100px;" type="text"/> CODE <input style="width: 100px;" type="text"/>
NEMA NOM EFFICIENCY <input style="width: 100px;" type="text" value="77.0"/> NOM PF <input style="width: 100px;" type="text" value="61.1"/> KiloWatt <input style="width: 100px;" type="text" value=".187"/>	NEMA NOM EFFICIENCY <input style="width: 100px;" type="text"/> NOM PF <input style="width: 100px;" type="text"/>
GUARANTEED EFFICIENCY <input style="width: 100px;" type="text" value="74.0"/> MAX KVAR <input style="width: 100px;" type="text"/> HZ <input style="width: 100px;" type="text" value="60"/>	GUARANTEED EFFICIENCY <input style="width: 100px;" type="text"/> MAX KVAR <input style="width: 100px;" type="text"/> HZ <input style="width: 100px;" type="text"/>

HAZARDOUS LOCATION DATA (IF APPLICABLE):

DIVISION <input style="width: 100%;" type="text"/>	CLASS I <input style="width: 100%;" type="text"/>	GROUP I <input style="width: 100%;" type="text"/>
TEMP CODE <input style="width: 100%;" type="text"/>	CLASS II <input style="width: 100%;" type="text"/>	GROUP II <input style="width: 100%;" type="text"/>

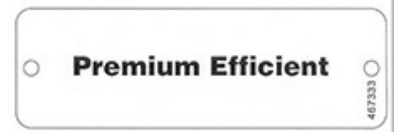

VFD DATA (IF APPLICABLE):

VOLTS <input style="width: 150px;" type="text" value="460"/> <input style="width: 150px;" type="text" value="230"/>	AMPS <input style="width: 150px;" type="text" value=".5"/> <input style="width: 150px;" type="text" value="1.1"/>
TORQUE 1 <input style="width: 150px;" type="text" value=".7LB-FT"/>	TORQUE 2 <input style="width: 150px;" type="text" value=".7-.35LB-FT"/>
VFD LOAD TYPE 1 <input style="width: 150px;" type="text" value="CT/VEC"/>	VFD LOAD TYPE 2 <input style="width: 150px;" type="text" value="CHP/VEC"/>
VFD HERTZ RANGE 1 <input style="width: 150px;" type="text" value="0-60"/>	VFD HERTZ RANGE 2 <input style="width: 150px;" type="text" value="60-120"/>
VFD SPEED RANGE 1 <input style="width: 150px;" type="text" value="0-1800"/>	VFD SPEED RANGE 2 <input style="width: 150px;" type="text" value="1800-3600"/>
SERVICE FACTOR <input style="width: 150px;" type="text" value="1.00"/>	FL SLIP <input style="width: 150px;" type="text" value="35"/>
NO. POLES <input style="width: 150px;" type="text" value="4"/>	MAGNETIZING AMPS <input style="width: 150px;" type="text" value=".4"/>
VECTOR MAX RPM <input style="width: 150px;" type="text" value="3600"/>	Encoder PPR <input style="width: 150px;" type="text"/>
Radians / Seconds <input style="width: 150px;" type="text" value="7.35"/>	Encoder Volts <input style="width: 150px;" type="text"/>

TEAO DATA (IF APPLICABLE):

HP (AIR OVER) <input style="width: 100px;" type="text"/>	HP (AIR OVER M/S) <input style="width: 100px;" type="text"/>	RPM (AIR OVER) <input style="width: 100px;" type="text"/>	RPM (AIR OVER M/S) <input style="width: 100px;" type="text"/>
FPM AIR VELOCITY <input style="width: 100px;" type="text"/>	FPM AIR VELOCITY M/S <input style="width: 100px;" type="text"/>	FPM AIR VELOCITY SEC <input style="width: 100px;" type="text"/>	

ADDITIONAL NAMEPLATE DATA:

Decal / Plate	WD=344136	Customer PN	
Notes		Non Rev Ratchet	
Max Temp Rise		OPP/Upper Oil Cap	GREASE
Thermal (WDG)	OVER TEMP PROT 2	SHAFT/Lower Oil Cap	GREASE
Altitude		Usable At	
Regulatory Notes		Regulatory Compliance	
COS		Marine Duty	
Balance	0.08 IN/SEC	Arctic Duty	
3/4 Load Eff.	75.3	Inrush Limit	
Motor Weight (LBS)	30	Direction of Rotation	
Sound Level		Special Note 1	
Vertical Thrust (LBS)		Special Note 2	
Thrust Percentage		Special Note 3	
Bearing Life		Special Note 4	
Starting Method		Special Note 5	
Number of Starts		Special Note 6	
200/208V 60Hz Max Amps		SH Max. Temp.	
190V 50 hz Max Amps		SH Voltage	
380V 50 Hz Max Amps		SH Watts	
NEMA Inertia		Load Inertia	
Sumpheater Voltage		Sumpheater Wattage	
Special Accessory Note 1		Special Accessory Note 16	
Special Accessory Note 2		Special Accessory Note 17	
Special Accessory Note 3		Special Accessory Note 18	
Special Accessory Note 4		Special Accessory Note 19	
Special Accessory Note 5		Special Accessory Note 20	
Special Accessory Note 6		Special Accessory Note 21	
Special Accessory Note 7		Special Accessory Note 22	
Special Accessory Note 8		Special Accessory Note 23	
Special Accessory Note 9		Special Accessory Note 24	
Special Accessory Note 10		Special Accessory Note 25	
Special Accessory Note 11		Special Accessory Note 26	
Special Accessory Note 12		Special Accessory Note 27	
Special Accessory Note 13		Special Accessory Note 28	
Special Accessory Note 14		Special Accessory Note 29	
Special Accessory Note 15		Special Accessory Note 30	
Heater in C/B Voltage		Heater in C/B Watts	
Zone 2 Group		Division 2 Service Factor	
Note 1		Note 2	
Note 3		Note 4	
Note 5		Note 6	
Note 7		Note 8	
Note 9		Note 10	
Note 11		Note 12	
Note 13		Note 14	
Note 15		Note 16	
Note 17		Note 18	
Note 19		Note 20	
Note 21		Note 22	

**NIDEC MOTOR CORPORATION
ST. LOUIS, MO**

TYPICAL NAMEPLATE DATA
ACTUAL MOTOR NAMEPLATE LAYOUT MAY VARY
SOME FIELDS MAY BE OMITTED



Nidec trademarks followed by the ® symbol are registered with the U.S. Patent and Trademark Office.

MOTOR PERFORMANCE

MODEL NO.	CATALOG NO.	PHASE	TYPE	FRAME
FD87	UN14T2BC	3	UTNX	56C
ORDER NO.		23234		LINE NO.
MPI:			147107	147108
HP:			0.25	0.25
POLES:			4	4
VOLTS:			460	230
HZ:			60	60
SERVICE FACTOR:			1	1
EFFICIENCY (%):				
S.F.				
FULL			77	77
3/4			75.3	75.3
1/2			68.9	68.9
1/4			53.9	53.9
POWER FACTOR (%):				
S.F.				
FULL			61.1	61.1
3/4			52	52
1/2			40.9	40.9
1/4			27.4	27.4
NO LOAD			11.6	11.6
LOCKED ROTOR			67.7	67.7
AMPS:				
S.F.				
FULL			0.5	1
3/4			0.4	0.9
1/2			0.4	0.8
1/4			0.4	0.8
NO LOAD			0.4	0.8
LOCKED ROTOR			4.1	8.2
NEMA CODE LETTER			P	P
NEMA DESIGN LETTER			A	A
FULL LOAD RPM			1765	1765
NEMA NOMINAL / EFFICIENCY (%)			77	77
GUARANTEED EFFICIENCY (%)			74	74
MAX KVAR			0.3	0.3
AMBIENT (°C)			40	40
ALTITUDE (FASL)			3300	3300
SAFE STALL TIME-HOT (SEC)			30	30
SOUND PRESSURE (DBA @ 1M)			0	0
TORQUES:				
BREAKDOWN{% F.L.}			586	586
LOCKED ROTOR{% F.L.}			419	419
FULL LOAD{LB-FT}			0.7	0.7

NEMA Nominal and Guaranteed Efficiencies are up to 3,300 feet above sea level and 25 ° C ambient.

The Above Data Is Typical, Sinewave Power Unless Noted Otherwise

NIDEC MOTOR CORPORATION
ST. LOUIS, MO





B109144

Motor Wiring Diagram 9 Lead, Dual Voltage (WYE Conn.)

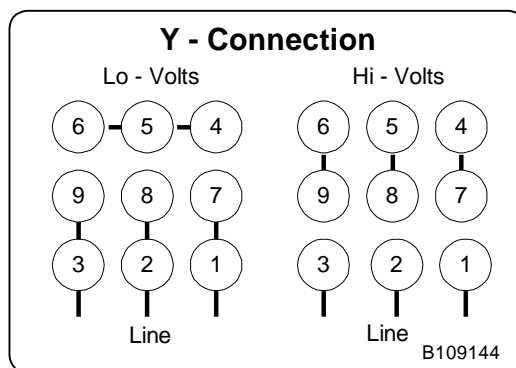
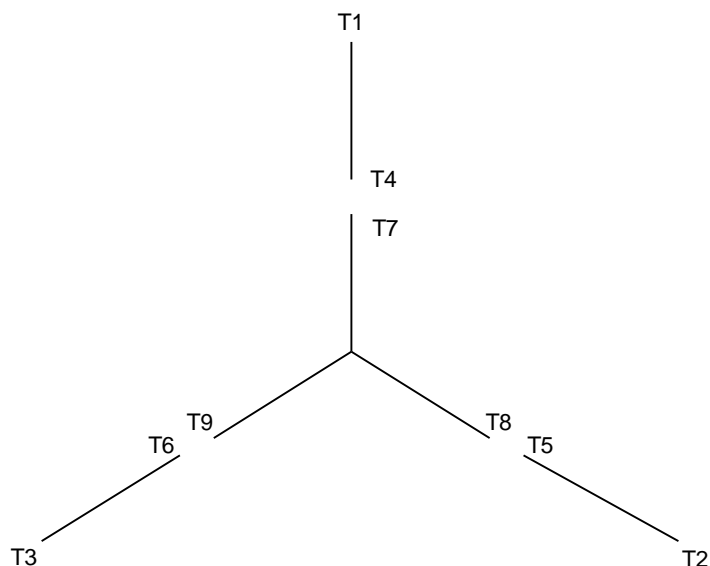

To reverse direction of rotation interchange connections L1 and L2.

Each lead may have one or more cables comprising that lead.
In such case each cable will be marked with the appropriate lead number.

THERMOSTATS

1. MOTOR IS EQUIPPED WITH QTY-3 (1 PER PHASE) NORMALLY CLOSED THERMOSTATS. THERMOSTATS ARE SET TO OPEN AT HIGH TEMPERATURE.
2. CONTACT RATINGS FOR THERMOSTATS: 120-600 VAC, 720 VA

N. C. THERMOSTATS

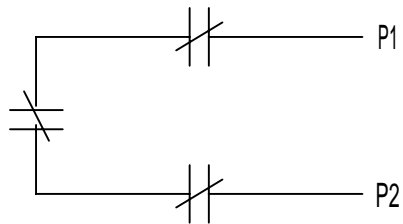

NOTE: THERMOSTATS LEADS MAY BE LOCATED IN EITHER THE MAIN OUTLET BOX OR IF SO EQUIPPED, AN AUXILIARY BOX.

ACCESSORY LISTING
QTY-3 N.C. THERMOSTATS

REVISION DESCRIPTION FOR: MISC	SCALE	UNITS	TITLE		NIDEC MOTOR CORPORATION
STL0211 - UPDATED FORMAT .	NONE	IN	CUSTOMER CONNECTION DIAGRAM		
	TOLERANCES ON DIMENSIONS (UNLESS OTHERWISE SPECIFIED)		ISSUED BY	APPROVED BY	REVISION DATE
MATERIAL:	<u>INCHES</u>	<u>mm</u>	R. KING	C. CADE	24-FEB-11
---	ANGLES X°= ±1°		CODE	DWG NO.	REV
				0834066	G
					SHEET NUMBER
					1 OF 1
					DWG SIZE
					A