



Installation, Use and Maintenance



(Original instructions)



MZERO

STAND ALONE PROGRAMMABLE SAFETY CONTROLLER

STAND ALONE PROGRAMMABLE SAFETY CONTROLLER

TABLE OF CONTENTS

INTRODUCTION	6
Contents of this handbook.....	6
Important safety instructions.....	6
Abbreviations and symbols	7
Applicable standards.....	7
OVERVIEW.....	8
Hardware description	8
Optional external relay units.....	8
Software description	8
PRODUCT COMPOSITION	8
INSTALLATION.....	9
Mechanical fastening	9
Calculation of safety distance of an ESPE connected to MZERO	9
Electrical connections	10
Instructions concerning connection cables.....	10
MZERO 16.4 PINOUT.....	11
USB input	12
Example of connection of MZERO to the machine control system.....	12
CHECKLIST AFTER INSTALLATION.....	13
OPERATING DIAGRAM.....	14
SIGNALS	15
INPUTS	15
RESTART_FBK.....	15
Digital INPUTS.....	15
OUTPUTS.....	16
OUT STATUS (SIL 1/PL c)	16
OUT TEST	16
OSSD SAFETY OUTPUTS	17
IMPORTANT NOTE CONCERNING OSSD SAFETY OUTPUTS	17
OSSD	17
OSSD OUTPUTS CONFIGURATION	18
TECHNICAL FEATURES	19
MZERO GENERAL SYSTEM CHARACTERISTICS	19
Safety level parameters.....	19
Enclosure parameters	19
Electric parameters.....	19
Environmental parameters	20
MECHANICAL DIMENSIONS	20
LED INDICATORS (Normal Operation)	21
LED INDICATORS (Diagnostic)	22
MZERO (Figure 12)	22
MZERO SAFETY DESIGNER SOFTWARE	23
Installing the software.....	23
PC HARDWARE requirements	23
PC SOFTWARE requirements	23
Installation of MZD software.....	23
Fundamentals.....	24
Standard tool bar.....	25

Textual tool bar.....	26
Create a new project (configure the MZERO system).....	26
Change user parameters	26
OBJECTS - OPERATOR - CONFIGURATION tool bars	27
Creating the diagram	28
USE OF MOUSE RIGHT BUTTON	28
Example of a project	30
Project validation	30
Resources Allocation	31
Project report.....	31
Connect to MZERO	35
Sending the configuration to MZERO	35
Download a configuration file (project) from MZERO	35
Configuration LOG	36
Disconnecting System	36
MONITOR (I/O status in real time - textual)	37
MONITOR (I/O status in real time - textual - graphic)	38
Password protection.....	39
Level 1 password	39
Level 2 password	39
Password Change	39
TESTING the system.....	40
OBJECT FUNCTION BLOCKS.....	41
OUTPUT OBJECTS	41
OSSD (safety outputs).....	41
STATUS (SIL 1/PL c output)	42
INPUT OBJECTS	43
E-STOP (emergency stop).....	43
E-GATE (safety gate device).....	44
SINGLE E-GATE (safety gate device)	45
LOCK FEEDBACK	46
ENABLE (enable key)	47
ESPE (optoelectronic safety light curtain / laser scanner).....	48
FOOTSWITCH (safety pedal).....	49
MOD-SEL (safety selector)	51
PHOTOCELL (safety photocell).....	51
TWO-HAND (bimanual control)	52
NETWORK_IN	53
SENSOR.....	53
S-MAT (safety mat).....	54
SWITCH	55
ENABLING GRIP SWITCH.....	56
TESTABLE SAFETY DEVICE.....	57
SOLID STATE DEVICE.....	58
RESTART INPUT	59
LL0-LL1	59
COMMENTS.....	59
TITLE	59
OPERATOR FUNCTION BLOCKS.....	60
LOGICAL OPERATORS	60
AND	60

NAND.....	60
NOT.....	61
OR.....	61
NOR.....	61
XOR.....	62
XNOR.....	62
LOGICAL MACRO.....	63
MULTIPLEXER.....	63
DIGITAL COMPARATOR.....	64
MEMORY OPERATORS.....	66
D FLIP FLOP (max number = 16).....	66
T FLIP FLOP (max number = 16).....	66
SR FLIP FLOP.....	66
USER RESTART MANUAL (max number = 16).....	67
USER RESTART MONITORED (max number = 16).....	68
MACRO RESTART MANUAL (max number = 16).....	68
MACRO RESTART MONITORED (max number = 16).....	69
PRE-RESET (max number = 32 with other RESTART operators).....	70
GUARD LOCK OPERATORS (max number = 4).....	71
GUARD LOCK.....	71
COUNTER OPERATORS.....	83
COUNTER (max number = 16).....	83
COUNTER COMPARATOR.....	84
TIMER OPERATORS (max number = 32).....	85
MONOSTABLE.....	85
MONOSTABLE_B.....	86
PASSING MAKE CONTACT.....	87
DELAY.....	88
LONG DELAY.....	89
DELAY COMPARATOR.....	90
DELAY LINE.....	90
CLOCKING.....	92
MUTING FUNCTION.....	93
MUTING OPERATORS (max number = 4).....	93
"Concurrent" MUTING.....	93
MUTING "L".....	94
"Sequential" MUTING.....	95
MUTING "T".....	96
MUTING OVERRIDE (max number = 4).....	97
MISCELLANEOUS FUNCTION BLOCKS.....	99
SERIAL OUTPUT (max number = 8).....	99
NETWORK (max number = 1).....	100
Example of application in Category 2 according to ISO 13849-1:.....	103
Logical block diagram of a safety function using the network.....	104
Example of application in Category 4 according to ISO 13849-1:.....	104
Logical block diagram of a safety function using the network.....	105
RESET.....	105
OSSD EDM (max number = 32).....	105
INTERPAGE IN/OUT.....	106
INTFBK_IN / INTFBK_OUT (max number = 8).....	107
SPECIAL APPLICATIONS.....	108

Output delay with manual	108
SIMULATOR FEATURE.....	109
Schematic Simulation.....	110
How to use graphic simulation.....	112
MZERO FAIL CODES.....	115
ACCESSORIES AND SPARE PARTS.....	116
WARRANTY	117
CE DECLARATION OF CONFORMITY	118
UKCA DECLARATION OF CONFORMITY.....	119

INTRODUCTION

Contents of this handbook











This handbook describes how to use the MZERO Stand Alone Programmable Safety Controller; it includes:

- a description of the system
- method of installation
- connections
- signals
- troubleshooting
- use of the MZD configuration SW

Important safety instructions

 This safety alert symbol indicates a potential **personal safety hazard**. Failure to comply with instructions bearing this symbol could pose a very serious risk to personnel.

 This symbol indicates an important instruction.

-  The MZERO is built to the following safety levels: SIL 3, SILCL 3, PL e, Cat. 4, Type 4 in accordance with the applicable standards. However, the definitive SIL and PL of the application will depend on the number of safety components, their parameters and the connections that are made, as per the risk analysis.
-  Read the "Applicable Standards" section carefully.
-  Perform an in-depth risk analysis to determine the appropriate safety level for your specific application, on the basis of all the applicable standards.
-  Programming/configuration of the MZERO is the sole responsibility of the installer or user.
-  The device must be programmed/configured in accordance with the application-specific risk analysis and all the applicable standards.
-  Once you have programmed/configured and installed the MZERO and all the relative devices, run a complete application safety test (see the "TESTING the system" section, page 40).
-  Always test the complete system whenever new safety components are added (see the "TESTING the system" page 40).
-  ReeR is not responsible for these operations or any risks in connection therewith.
-  Reference should be made to the handbooks and the relative product and/or application standards to ensure correct use of devices connected to the MZERO within the specific application.
-  The ambient temperature in the place where the system is installed must be compatible with the operating temperature parameters stated on the product label and in the specifications.
-  For all matters concerning safety, if necessary, contact your country's competent safety authorities or the competent trade association.

Abbreviations and symbols

MZD =	MZERO Safety Designer: <i>MZERO configuration SW running in Windows</i>
LL0, LL1 =	Logic Level 0, Logic Level 1
OSSD =	Output Signal Switching Device: <i>solid state safety output</i>
MTTF_d =	Mean Time to Dangerous Failure
PL =	Performance Level
PFH_d =	Probability of a dangerous failure per Hour
SIL =	Safety Integrity Level
SILCL =	Safety Integrity Level Claim Limit
SW =	Software

Applicable standards

MZERO complies with the following European Directives:

- **2006/42/EC** "Machinery Directive"
- **2014/30/EU** "Electromagnetic Compatibility Directive"
- **2014/35/EU** "Low Voltage Directive"

and is built to the following standards:

CEI EN 61131-2	Programmable controllers, part 2: Equipment requirements and tests
EN ISO 13489-1	Safety of machinery: Safety related parts of control systems. General principles for design
EN 61496-1	Safety of machinery: Electro-sensitive protective equipment. Part 1: General requirements and tests.
EN 61508-1	Functional safety of electrical/electronic/programmable electronic safety-related systems: General requirements.
EN 61508-2	Functional safety of electrical/electronic/programmable electronic safety-related systems: Requirements for electrical/electronic/programmable electronic safety-related systems.
EN 61508-3	Functional safety of electrical/electronic/programmable electronic safety-related systems: Software requirements.
EN 61508-4	Functional safety of electrical/electronic programmable electronic safety related systems: Definitions and abbreviations.
IEC 61784-3	Digital data communication for measurement and control: Functional safety fieldbuses.
EN 62061	Safety of machinery. Functional safety of safety-related electrical, electronic and programmable electronic control systems
EN 81-20	Safety rules for the construction and installation of lifts. Lifts for the transport of persons and goods. Passenger and goods passenger lifts
EN 81-50	Safety rules for the construction and installation of lifts. Examinations and tests. Design rules, calculations, examinations and tests of lift components

Table 1

OVERVIEW

Hardware description

MZERO is a Stand Alone Programmable Safety Controller.

It can be configured using the MZD graphic interface and is equipped with:

- 16 Safety Inputs
- 4 independent programmable Restart/EDM Inputs
- 4 independent dual channel Safety Outputs (OSSD)
- 4 SIL 1/PL c - Status outputs
- 4 Test Outputs

MZERO is capable of monitoring the following safety sensors and commands:

- optoelectronic sensors (safety light curtains, scanners, safety photocells)
- mechanical switches
- safety mats
- emergency stops
- two-hand controls
- RFID safety sensors

Optional external relay units

The **MR2**, **MR4** and **MR8** expansion units provide MZERO with 2, 4 and 8 N.O. guided contact safety relay outputs, respectively, with the related external relay feedback (N.C. contact).

➔ Refer to the specific description of this units on the relative technical sheet.

Software description

MZD software is capable of creating complex logics, using logical operators and safety functions such as muting, timer, counters, etc.

All this is performed through an easy and intuitive graphic interface.

The configuration performed on the PC is sent to the controller via USB connection; the file resides in the MZERO memory.

➔ MZERO is certified to the maximum safety level envisaged by the applicable industrial safety standards (SIL 3, SILCL 3, PL e, Cat. 4).

PRODUCT COMPOSITION

MZERO is supplied with:

- 1) MZERO Stand Alone Programmable Safety Controller.
- 2) Multi-language installation sheet containing QR-code concerning:
 - a) Link to the ReeR safety website area containing this multi-language installation manual.
 - b) Link to ReeR safety website area containing th MZD Intallation Software.

INSTALLATION

Mechanical fastening

Fix the MZERO system unit to a 35mm DIN rail as follows:

1. Fasten the controller to the rail. Press the unit gently until you feel it snap into place.
2. To remove the unit, use a screwdriver to pull down the locking latch on the back of the unit; then lift the unit upwards and pull.

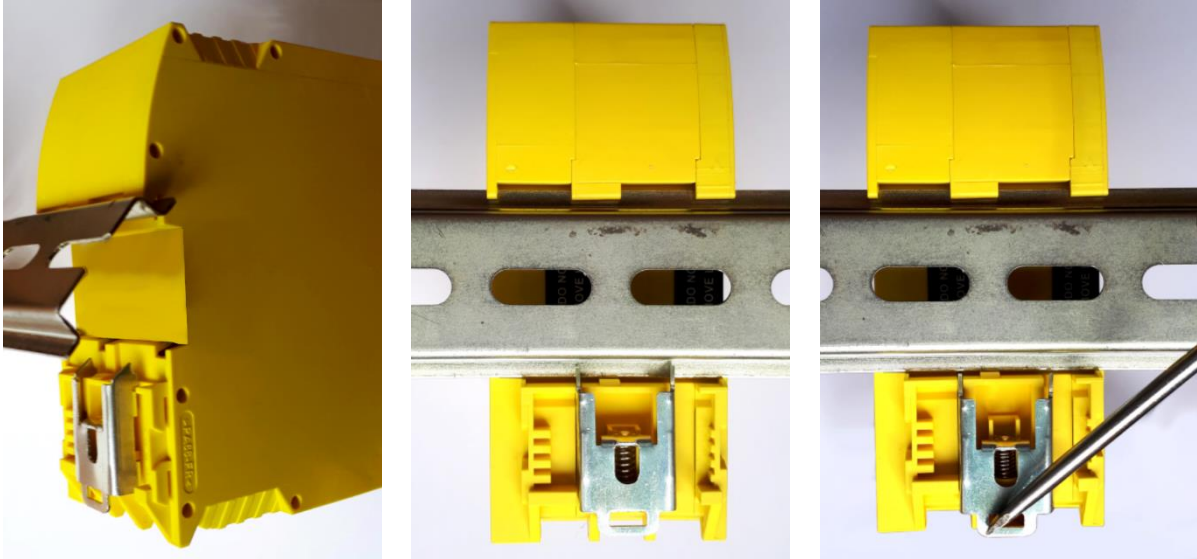

Figure 1

Calculation of safety distance of an ESPE connected to MZERO

Any Electro-sensitive Protective Equipment device connected to MZERO, must be positioned at a distance equal to or greater than the minimum safety distance **S** so that the dangerous point can be reached only after stopping the dangerous movement of the machine.

- The european standard:
 - ISO 13855:2010- (EN 999:2008) "*Safety of machinery - Positioning of safeguards with respect to the approach speeds of parts of the human body.*"¹
 provides the elements to calculate the proper safety distance.
- Carefully read the installation manual of each device for specific information on the correct positioning.
- Remember that the total response time depends on:
 MZERO response time + ESPE response time + response time of the machine (i.e. the time taken by the machine to stop the dangerous movement from the moment in which the stop signal is transmitted).

¹ "Describe the methods that designers can use to calculate the minimum safety distance from a specific dangerous point for the safety devices, particularly Electro-sensitive devices (eg. light curtains), safety-mats or pressure sensitive floors and bimanual control. It contains a rule to determine the placement of safety devices based on approach speed and the stopping time of the machine, which can reasonably be extrapolated so that it also includes the interlocking guards without guard locking."

Electrical connections

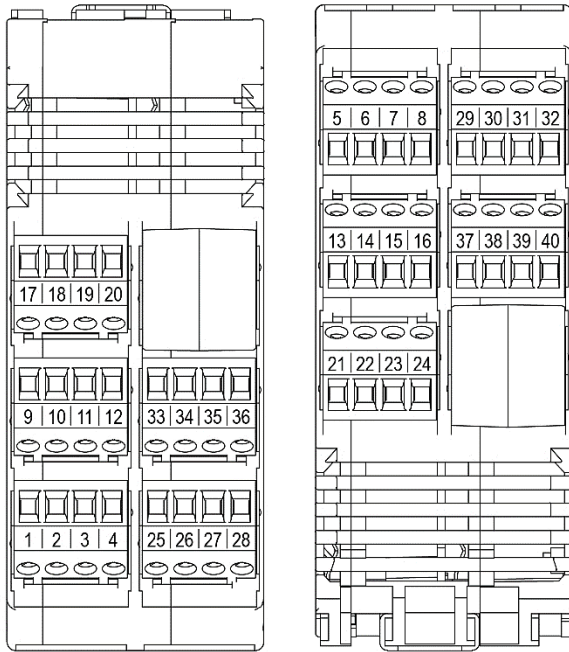

Figure 2

The MZERO controller is provided with terminal blocks for the electrical connections.
The unit provides 40 terminals.

→ Terminal tightening torque: 5...7lb-in (0,6...0,7 Nm).

- Install the safety controller in an enclosure with a protection class of at least IP54.
- Connect the module when it is not powered.
- The supply voltage to the units must be 24Vdc \pm 20% (PELV, in compliance with the standard EN 60204-1 (Chapter 6.4)).
- Do not use the MZERO to supply external devices.
- The same ground connection (0VDC) must be used for all system components.

Instructions concerning connection cables.

- Wire size range: AWG 12...30, (solid/stranded) (UL).
- Use 60/75°C copper (Cu) conductor only.
- We recommend the use of separate power supplies for the safety controller and for other electrical power equipment (electric motors, inverters, frequency converters) or other sources of disturbance.
- Cables used for connections longer than 50m must have a cross-section of at least 1mm² (AWG16).

MZERO 16.4 PINOUT

TERMINAL	SIGNAL	TYPE	DESCRIPTION	OPERATION
1	24VDC	-	24VDC power supply	-
2	24VDC	-	24VDC power supply	-
3	NC	-	-	-
4	0VDC	-	0VDC power supply	-
5	OSSD1_A	Output	Static output 1	PNP active high
6	OSSD1_B	Output		PNP active high
7	RESTART_FBK1	Input	Feedback/Restart 1	Input (type 2) according to EN 61131-2
8	OUT_STATUS1	Output	SIL 1/PL c output	PNP active high
9	OSSD2_A	Output	Static output 2	PNP active high
10	OSSD2_B	Output		PNP active high
11	RESTART_FBK2	Input	Feedback/Restart 2	Input (type 2) according to EN 61131-2
12	OUT_STATUS2	Output	SIL 1/PL c output	PNP active high
13	OSSD3_A	Output	Static output 1	PNP active high
14	OSSD3_B	Output		PNP active high
15	RESTART_FBK3	Input	Feedback/Restart 1	Input (type 2) according to EN 61131-2
16	OUT_STATUS3	Output	SIL 1/PL c output	PNP active high
17	OSSD4_A	Output	Static output 2	PNP active high
18	OSSD4_B	Output		PNP active high
19	RESTART_FBK4	Input	Feedback/Restart 2	Input (type 2) according to EN 61131-2
20	OUT_STATUS4	Output	SIL 1/PL c output	PNP active high
21	OUT_TEST1	Output	Short circuit detection output	PNP active high
22	OUT_TEST2	Output	Short circuit detection output	PNP active high
23	OUT_TEST3	Output	Short circuit detection output	PNP active high
24	OUT_TEST4	Output	Short circuit detection output	PNP active high
25	INPUT1	Input	Digital input 1	Input (type 3) according to EN 61131-2
26	INPUT2	Input	Digital input 2	Input (type 3) according to EN 61131-2
27	INPUT3	Input	Digital input 3	Input (type 3) according to EN 61131-2
28	INPUT4	Input	Digital input 4	Input (type 3) according to EN 61131-2
29	INPUT5	Input	Digital input 5	Input (type 3) according to EN 61131-2
30	INPUT6	Input	Digital input 6	Input (type 3) according to EN 61131-2
31	INPUT7	Input	Digital input 7	Input (type 3) according to EN 61131-2
32	INPUT8	Input	Digital input 8	Input (type 3) according to EN 61131-2
33	INPUT9	Input	Digital input 9	Input (type 3) according to EN 61131-2
34	INPUT10	Input	Digital input 10	Input (type 3) according to EN 61131-2
35	INPUT11	Input	Digital input 11	Input (type 3) according to EN 61131-2
36	INPUT12	Input	Digital input 12	Input (type 3) according to EN 61131-2
37	INPUT13	Input	Digital input 13	Input (type 3) according to EN 61131-2
38	INPUT14	Input	Digital input 14	Input (type 3) according to EN 61131-2
39	INPUT15	Input	Digital input 15	Input (type 3) according to EN 61131-2
40	INPUT16	Input	Digital input 16	Input (type 3) according to EN 61131-2

Table 2

USB input

MZERO Stand Alone Programmable Safety Controller includes a mini USB 2.0 connector for connection to a Personal Computer with **MZD** (MZERO Designer) configuration SW installed. A USB cable of the correct size is available as an accessory (**CSU**).

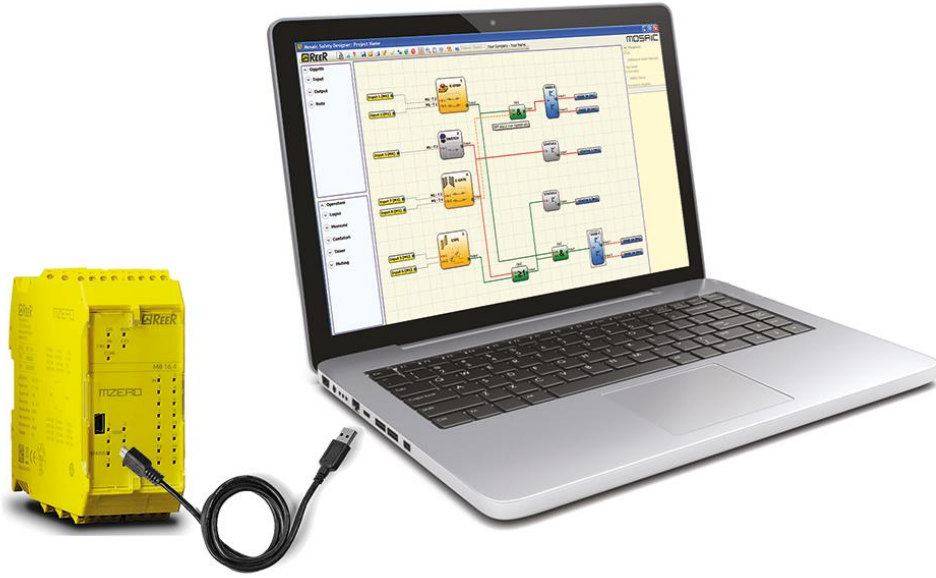

Figure 3 - USB 2.0 front panel connector for PC

Example of connection of MZERO to the machine control system

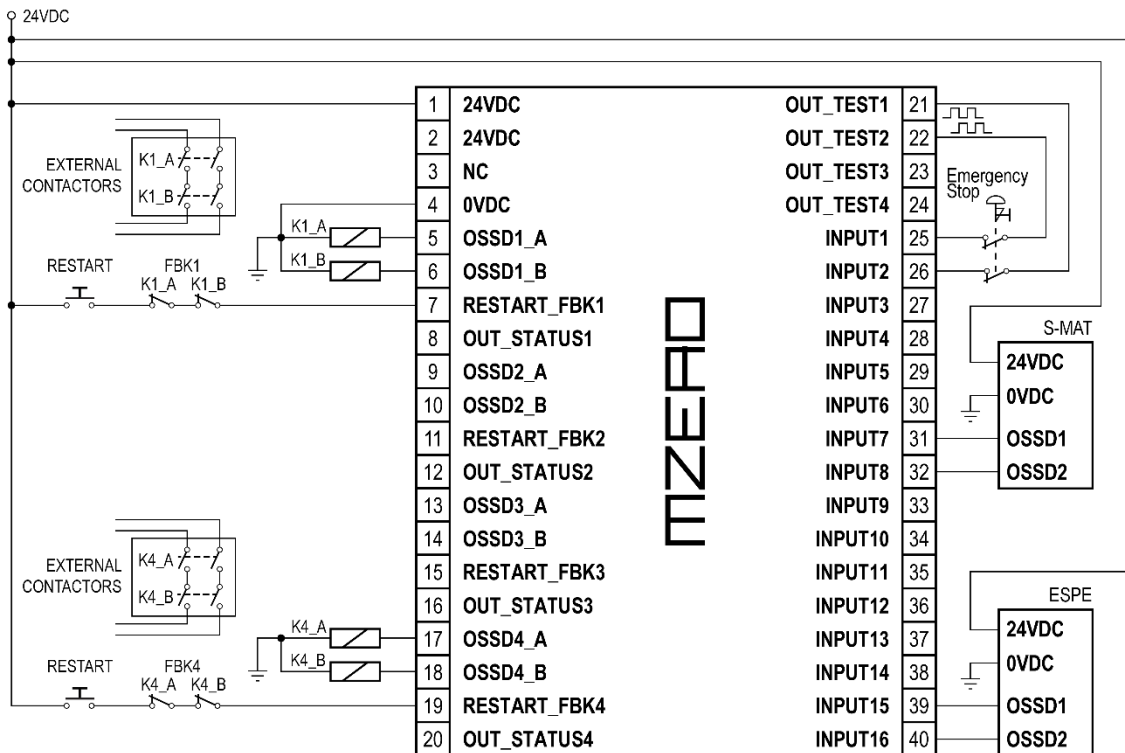

Figure 4 - Example of connection

CHECKLIST AFTER INSTALLATION

The MZERO unit is able to detect in real time the faults.

Anyway to have the system perfect operation perform the following checks at start up and at least every one year:

OPERATION / CONTROL	COMPLETE
1. Operate a complete system TEST (see "TESTING the system")	<input type="checkbox"/>
2. Verify that all the cables are correctly inserted and the terminal blocks well screwed.	<input type="checkbox"/>
3. Verify that all the leds (indicators) light on correctly.	<input type="checkbox"/>
4. Verify the positioning of all the sensors connected to MZERO.	<input type="checkbox"/>
5. Verify the correct fixing of MZERO to the Omega rail.	<input type="checkbox"/>
6. Verify that all the external indicators (lamps) work properly.	<input type="checkbox"/>

➔ After installation, maintenance and after any eventual configuration change perform a System TEST as described in the paragraph "TESTING the system".

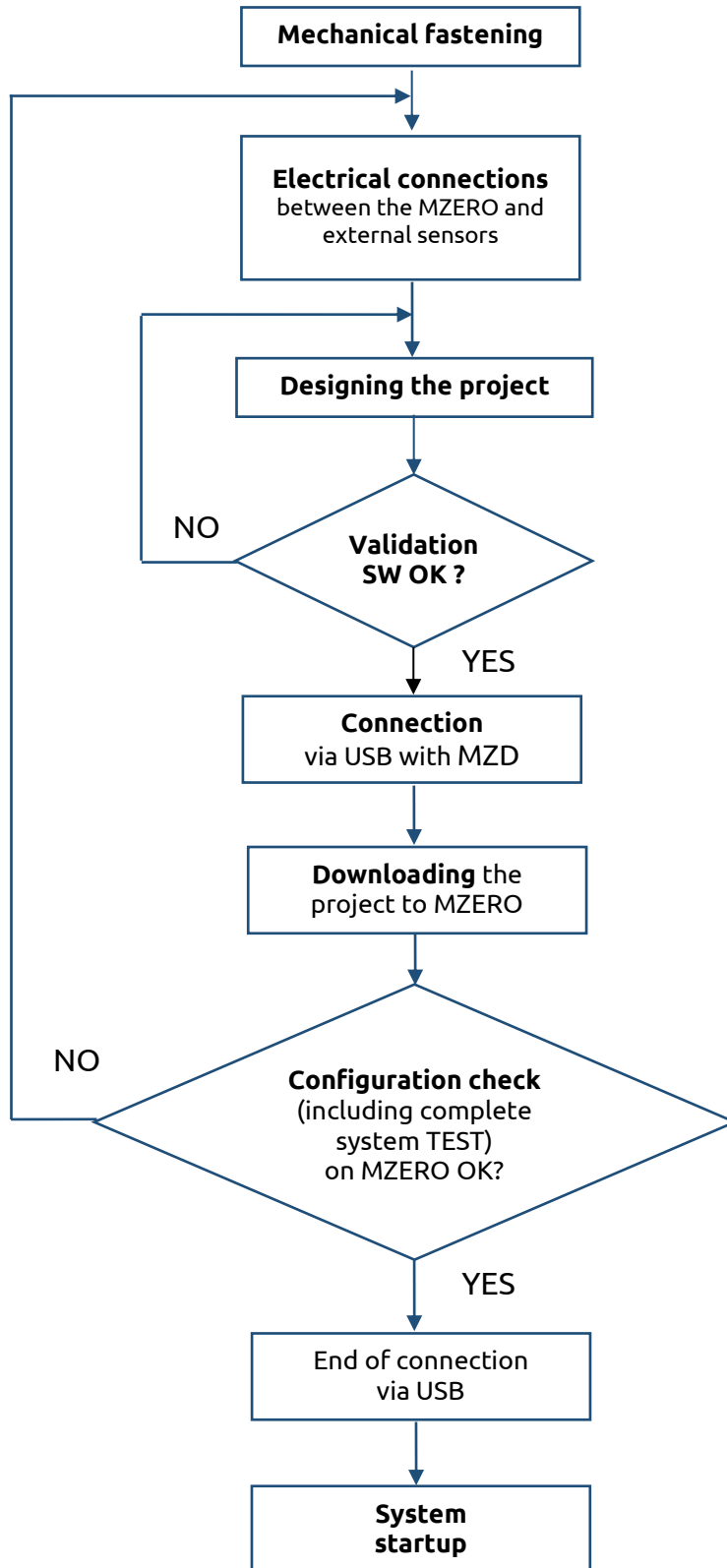
OPERATING DIAGRAM

SIGNALS

INPUTS

RESTART_FBK

The four RESTART_FBK (EN 61131-2, Type 2) signal inputs allow MZERO to verify an EDM (External Device Monitoring) feedback signal (series of contacts) from the external contactors and to monitor Manual/Automatic operation (RESTART function). (See the list of possible connections in Table 3).

- If the application requires it, the response time of the external contactors must be verified by an additional device.
- The RESTART command must be installed outside the danger area in a position where the danger area and the entire work area concerned are clearly visible.
- It must not be possible to reach the control from inside the danger area.

MODE OF OPERATION	EDM	RESTART_FBK
AUTOMATIC	With K1_K2 control	
	Without K1_K2 control	
MANUAL	With K1_K2 control	
	Without K1_K2 control	

Table 3

➔ RESTART_FBK inputs can also be used as Digital INPUTS (del manuale istruzioni scaricabile dal sito web Reer) when not used in Restart_Fbk mode.

Digital INPUTS

- MZERO provides 16 high active PNP digital inputs (terminals 25...40) that allow connection to project hardware components. These inputs are designed according to EN 61131-2 Type 3.
- In addition to the 16 digital inputs, MZERO can also use the 4 RESTART_FBK inputs (terminals 7, 11, 15, 19) as individual digital inputs. These inputs do not have all the possible configurations of the 16 digital inputs and can only use the RESTART INPUT function block (see RESTART INPUT section on page 59).

OUTPUTS

OUT STATUS (SIL 1/PL c)

The OUT STATUS signal is a Programmable SIL 1/PL c output that can indicate the status of:

- An input.
- An output.
- A node of the logic diagram designed using the MZD.

OUT TEST

The OUT TEST signals must be used to monitor the presence of short-circuits or overloads on the inputs (Figure 5).

- ➔ The maximum number of controllable inputs for each output OUT TEST is 4 INPUTs (parallel connection).
- ➔ The maximum allowed length for OUT TEST signal connections is = 100m.

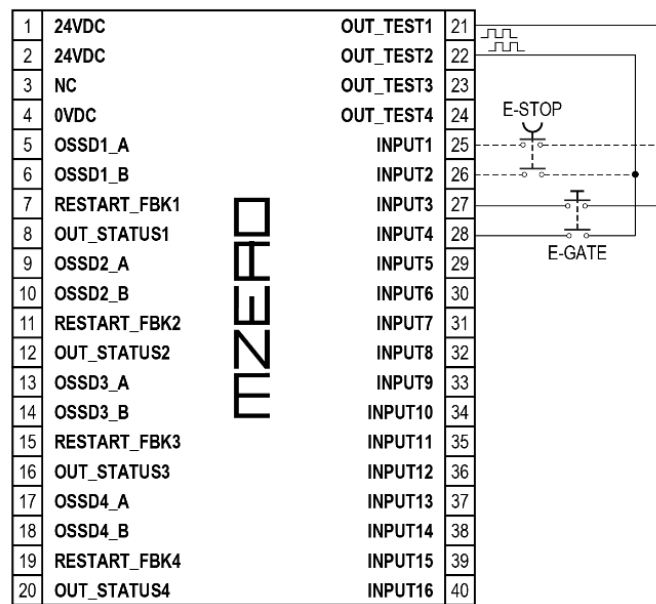

Figure 5

OSSD SAFETY OUTPUTS

IMPORTANT NOTE CONCERNING OSSD SAFETY OUTPUTS

➔ OSSD safety outputs are periodically tested against possible stuck to 0V or +24VDC or against bad cabling (e.g. two OSSD outputs shorted together). The test method chosen to perform this safety check is the “voltage dip” test: periodically (every 120 ms) and for a very short time (< 120 μs) each OSSD output is forced to 0VDC and if the test results are not consistent the system goes in fail and into a safe state.

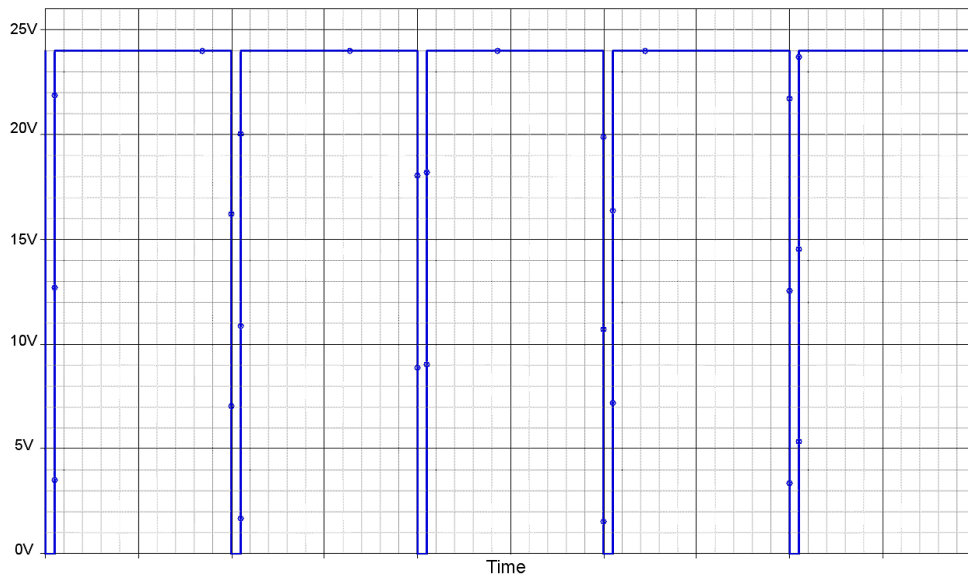

Figure 6 – Voltage dip test

OSSD

MZERO is equipped with OSSD (*static semiconductor safety outputs*) dual channel.

These outputs are short circuit protected, cross circuit monitored and supply:

- In the ON condition: **(Uv-1,2V)...Uv** ($Uv = 24VDC \pm 20\%$)
- In the OFF condition: **0V...2V r.m.s.**

The maximum load is 400mA@24V and corresponds to a minimum resistive load of 60Ω.

The maximum capacitive load is 0.68 μF. The maximum inductive load is 2 mH.

➔ External devices cannot be connected to the outputs unless explicitly planned in the MZD program configuration project.

- ⚠ Common cause failures between OSSD outputs must be excluded by observing an appropriate cable installation (i.e. separate cable paths).
- ⚠ In conditions of active outputs the module provides on both outputs a voltage equal to 24V referred to 0VDC. The load must therefore be connected between the output terminals and 0VDC.

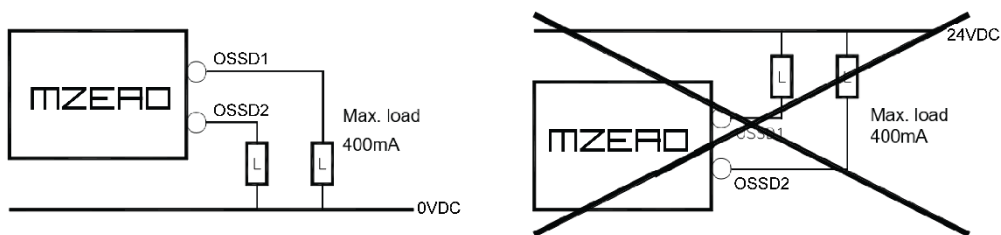

Figure 7 – OSSD correct wiring

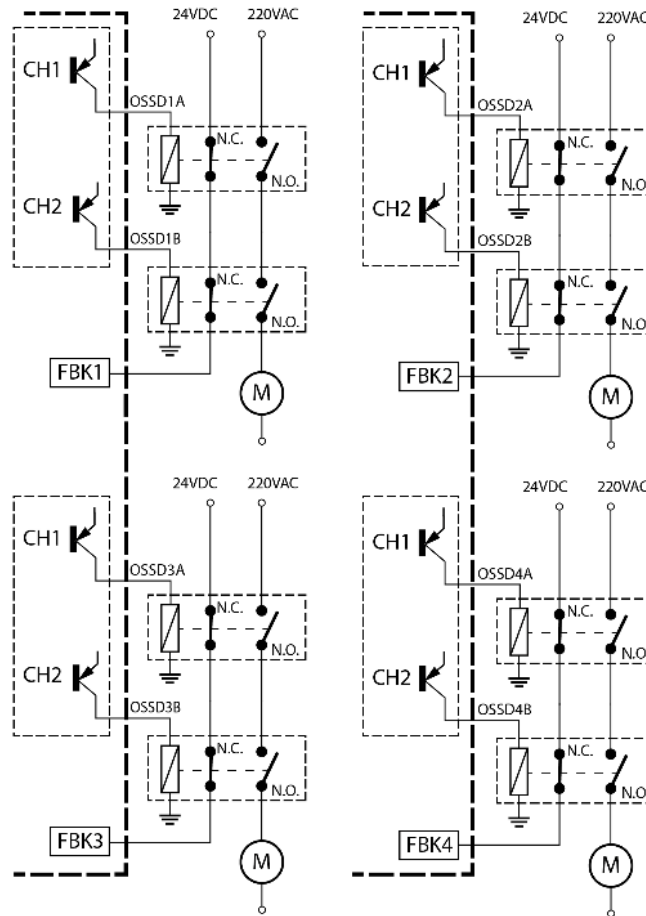

Figure 8 - Configuration with dual channel OSSD outputs (safety category SIL3/Pl e)

OSSD OUTPUTS CONFIGURATION

Each OSSD output can be configured as shown in Table 4:

Automatic	The output is activated according to the configurations set by the MZD SW only if the corresponding RESTART_FBK input is connected to 24VDC.
Manual	The output is activated according to the configurations set by the MZD SW only if corresponding RESTART_FBK input FOLLOWS A LOGIC TRANSITION OF 0-->1.
Monitored	The output is activated according to the configurations set by the MZD SW only if the corresponding RESTART_FBK input FOLLOWS A LOGIC TRANSITION OF 0-->1-->0.

Table 4

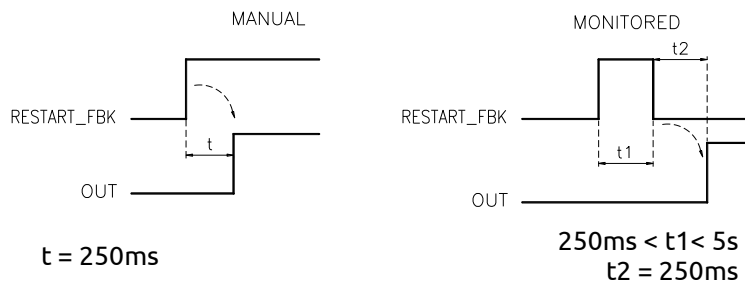

Figure 9

➔ It is not allowed the connection of external devices to the outputs, except as expected in the configuration performed with the MZD software.

TECHNICAL FEATURES

MZERO GENERAL SYSTEM CHARACTERISTICS

Safety level parameters

Parameter	Value	Standard
PFH _d	1,50E-8	EN 61508:2010
SIL	3	
SFF	99,7%	
HFT	1	
Safety standard	Type B	
SILCL	3	EN 62061:2005 / A2:2015
Type	4	EN 61496-1:2013
PL	E	EN ISO 13849-1:2015 EN 62061:2005 / A2:2015
Dc _{avg}	98,9%	
MTTF _d (years)	160,81	
Category	4	
Device lifetime	20 years	
Pollution degree	2	

Enclosure parameters

Description	Electronic housing 40 pole, with locking latch mounting
Enclosure material	Polyamide
Enclosure protection class	IP 20
Terminal blocks protection class	IP 2X
Fastening	Quick coupling to rail according to EN 60715
Dimensions (h x l x d)	108 x 45 x 114.5

Electric parameters

Rated voltage	24VDC ± 20% / PELV, Protective Class III; UL: Supply from class 2 (LVLE)
Dissipated power	6W max
Response time	22...24 ms
Digital INPUTS (No./description)	16 / PNP active high according to EN 61131-2 (type 3)
INPUT FBK/RESTART (No./description)	4 / possible Automatic or Manual operation with RESTART button, PNP active high according to EN 61131-2 (type 2)
Test OUTPUT (No./description)	4 / to check for short-circuits - overloads
SIL 1/PL c OUTPUTS (No./description)	4 / programmable - PNP active high
OSSD (No./description)	4 pairs / solid state safety outputs PNP active high 400mA@24VDC max Interface type C class 3 (ZVEI CB24I)
Connection to PC	USB 2.0 (Hi Speed) - Max cable length: 3m
Connection cable cross-section	0,5...2,5 mm ² / AWG 12...30 (solid/stranded)
Max length of connections	100m

Environmental parameters

Operating temperature	-10...55°C
Max surrounding air temperature	55°C (UL)
Storage temperature	-20...85°C
Relative humidity	10%...95%
Max. altitude (above sea level)	2000 m

MECHANICAL DIMENSIONS

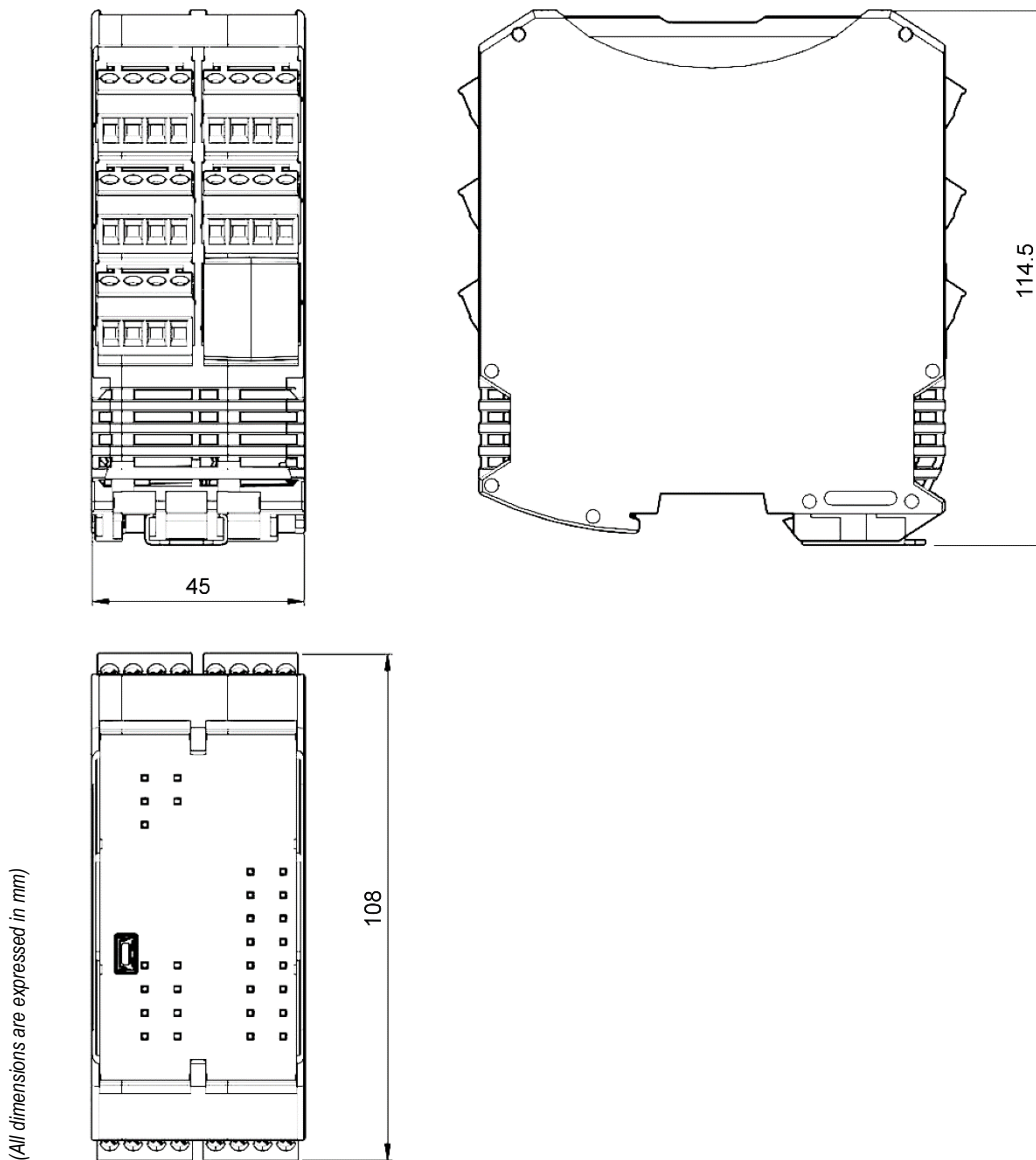
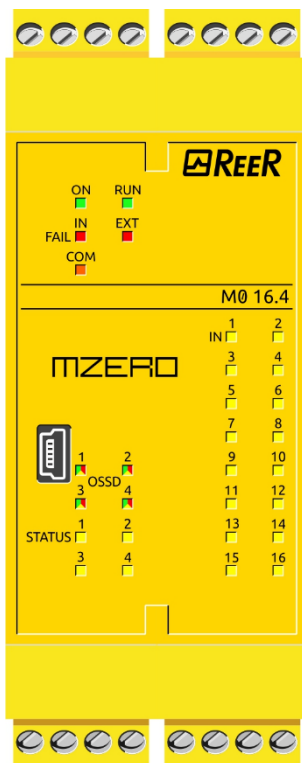

Figure 10

LED INDICATORS (Normal Operation)



MEANING	LED						
	RUN GREEN	IN FAIL RED	EXT FAIL RED	COM ORANGE	IN1÷16 YELLOW	OSSD1÷4 RED/GREEN	STATUS1÷4 YELLOW
Power on - initial TEST	ON	ON	ON	ON	ON	Red	ON
MZD requesting connection: MZERO internal configuration not present	OFF	OFF	OFF	Flashes slowly	OFF	Red	OFF
MZD connected - MZERO stopped	OFF	OFF	OFF	ON	OFF	Red	OFF

Table 5 - Opening Screen

MEANING	LED						
	RUN GREEN	IN FAIL RED	EXT FAIL RED	COM ORANGE	IN1÷16 YELLOW	OSSD1÷4 RED/GREEN/YELLOW	STATUS1÷4 YELLOW
NORMAL OPERATION	ON	OFF	OFF operation OK	<ul style="list-style-type: none"> ON = MZERO connected to PC OFF = otherwise 	INPUT condition	<ul style="list-style-type: none"> RED with output OFF GREEN with output ON YELLOW waiting for restart BLINKING YELLOW with inconsistent feedback (when required) 	OUTPUT condition
EXTERNAL FAULT DETECTED	ON	OFF	ON incorrect external connection detected	<ul style="list-style-type: none"> ON = MZERO connected to PC OFF = otherwise 	only the number of the INPUT with the incorrect connection flashes		

Table 6 - Dynamic Screen

Figure 11 - Signals

LED INDICATORS (Diagnostic)

MZERO (Figure 12)

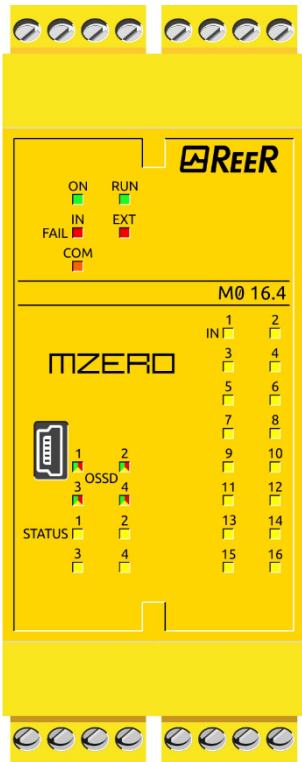

Figure 12 - Diagnostic

MEANING	LED									SOLUTION
	RUN GREEN	IN FAIL RED	EXT FAIL RED	COM ORANGE	IN1÷8 YELLOW	ENA BLUE	OSSD1/2 RED/GREEN	CLEAR1/2 YELLOW	STATUS1/2 YELLOW	
Internal fault	OFF	2 or 3 flashes	OFF	OFF	OFF	OFF	Red	OFF	OFF	Return the unit to ReeR to be repaired
OSSD output error	OFF	4 flashes	OFF	OFF	OFF	OFF	4 flashes (only the LED corresponding to the output in FAIL mode)	OFF	OFF	<ul style="list-style-type: none"> Check the OSSD1/2 connections If the problem persists return the MZERO to ReeR to be repaired

Table 7 - Dynamic Screen

MZERO SAFETY DESIGNER SOFTWARE

The "**MZERO SAFETY DESIGNER**" (**MZD**) application software can be used to configure a logic diagram of the connections between MZERO and the components of the system being developed. The MZERO will thus monitor and control the connected safety components.

The MZD uses a versatile graphic interface to establish the connections between the various components, as described below.

Installing the software

PC HARDWARE requirements

- RAM: 2 MB (minimum to run 7 with Service Pack 1 + Framework 4.8)
- Hard disk: \geq 500 MB free space
- USB port: 2.0 or greater
- Internet connection for installation program download

PC SOFTWARE requirements

- Windows 7 with Service Pack 1 installed (or higher OS)
- Microsoft Framework 4.8 must be installed on the PC

Installation of MZD software

- Run the "SetupDesigner.exe" file downloading the last available version from the Download section of the Reer website:
<https://www.reersafety.com/it/en/download/configuration-software>.
- Follow the indications of the setup.

➔ When the installation procedure is complete a window is displayed asking you to close the setup program.

Fundamentals

- Once the MZD has been correctly installed it creates an icon on the desktop. To launch the program: double-click on this icon. => 
- The opening screen shown below is displayed:

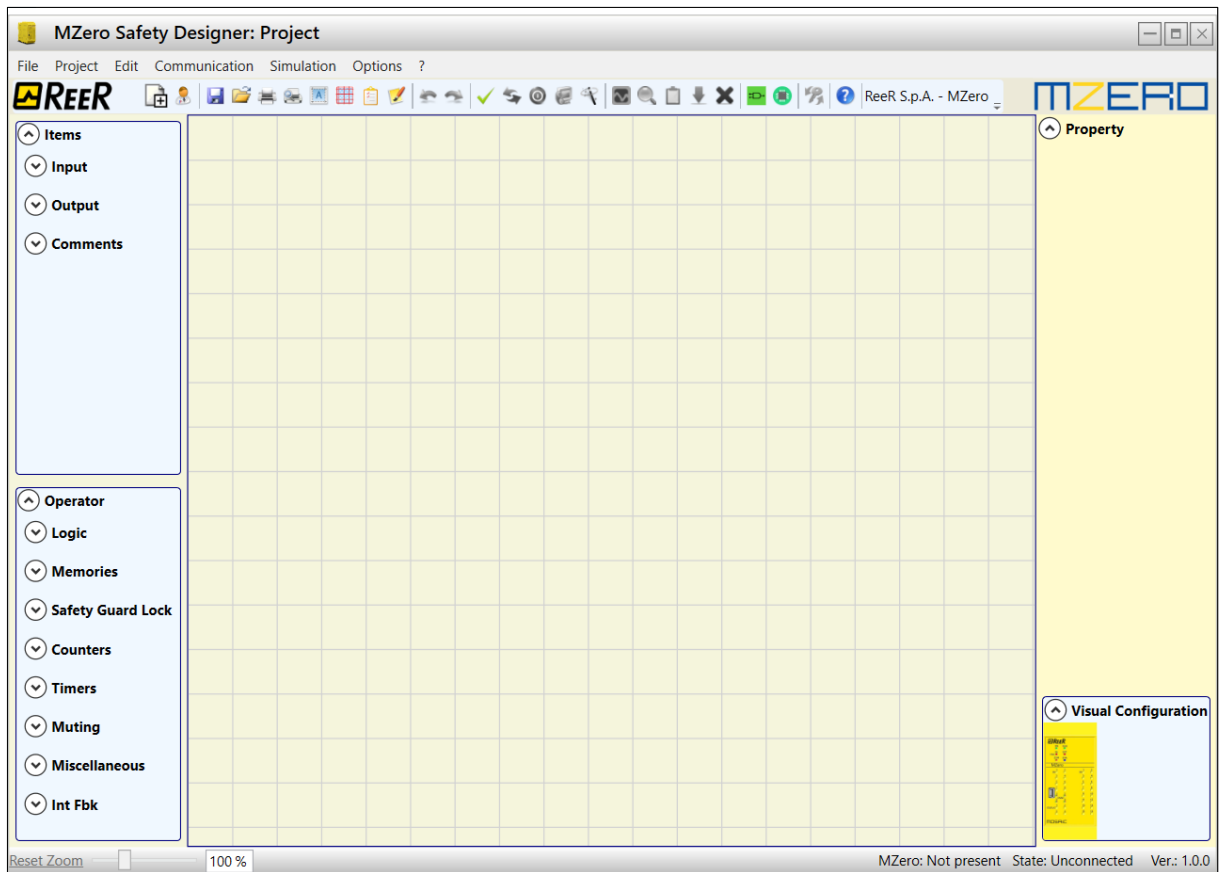

Figure 13

You are now ready to create your project.

Standard tool bar

The standard tool bar is shown in Figure 14. The meanings of the icons are listed below:



Figure 14

1		CREATE A NEW PROJECT
2		CHANGE USER PARAMETERS (name, company, etc)
3		SAVE THE ACTUAL PROJECT
4		LOAD AN EXISTING PROJECT (FROM THE PC)
5		PRINT THE PROJECT SCHEMATIC
6		PRINT PREVIEW
7		PRINTING AREA
8		SNAP TO GRID
9		RESOURCES ALLOCATION
10		PRINT THE PROJECT REPORT
11		UNDO (CANCEL THE LAST COMMAND)
12		REDO (RESTORE THE LAST CANCELLATION)
13		VALIDATE THE PROJECT
14		CONNECT TO MZERO
15		SEND PROJECT TO MZERO
16		DISCONNECT FROM MZERO
17		DOWNLOAD AN EXISTING PROJECT (FROM MZERO)
18		MONITOR (Real time I/O status - graphic)
19		MONITOR (Real time I/O status - textual)
20		DOWNLOAD LOG FILE
21		SHOW SYSTEM CONFIGURATION
22		DOWNLOAD ERRORS LOG
23		DELETE ERRORS LOG
24		SCHEMATIC SIMULATION
25		GRAPHIC SIMULATION
26		CHANGE PASSWORD
27		HELP ON-LINE
28		PASSWORD RECOVERY (only with the unlock file, see Level 2 password)

Textual tool bar

Optionally the textual tool bar shown below is also available (drop down).

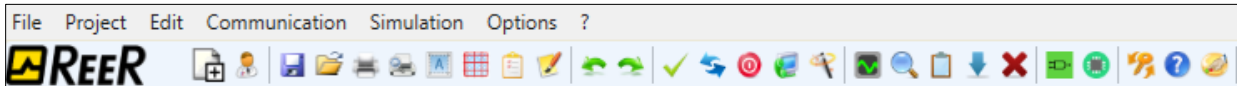

Figure 15

Create a new project (configure the MZERO system)

- Select icon CREATE (Figure 14) from the standard tool bar to start a new project. The user authentication window is displayed (Figure 16).

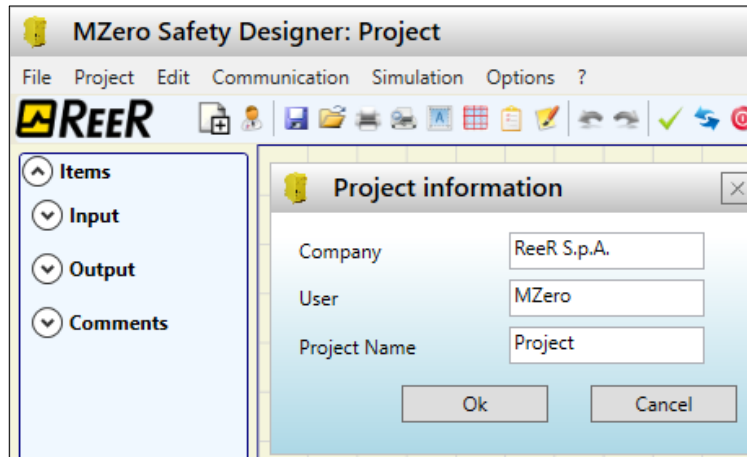

Figure 16

- Next the MZD displays a window showing the MZERO controller on the right-bottom angle.

Change user parameters

The change of user parameters is obtained with the icon .

The dialog user identification request appears (Figure 17). To accomplish this operation is not necessary to Log out from MZERO. Generally it serves when the-user must create a new project (even using a previously created).

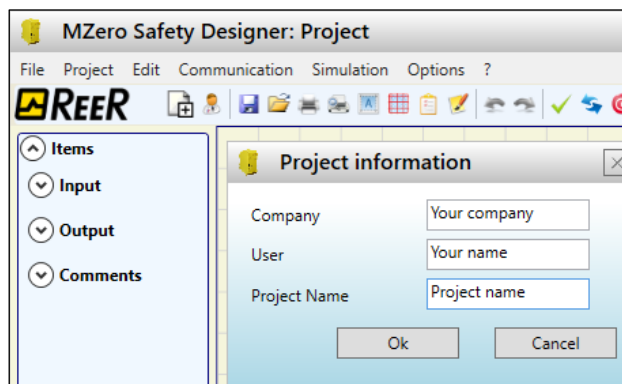

Figure 17

OBJECTS - OPERATOR - CONFIGURATION tool bars

Three large tool windows are displayed to the left and right of the main window (shown in Figure 18):

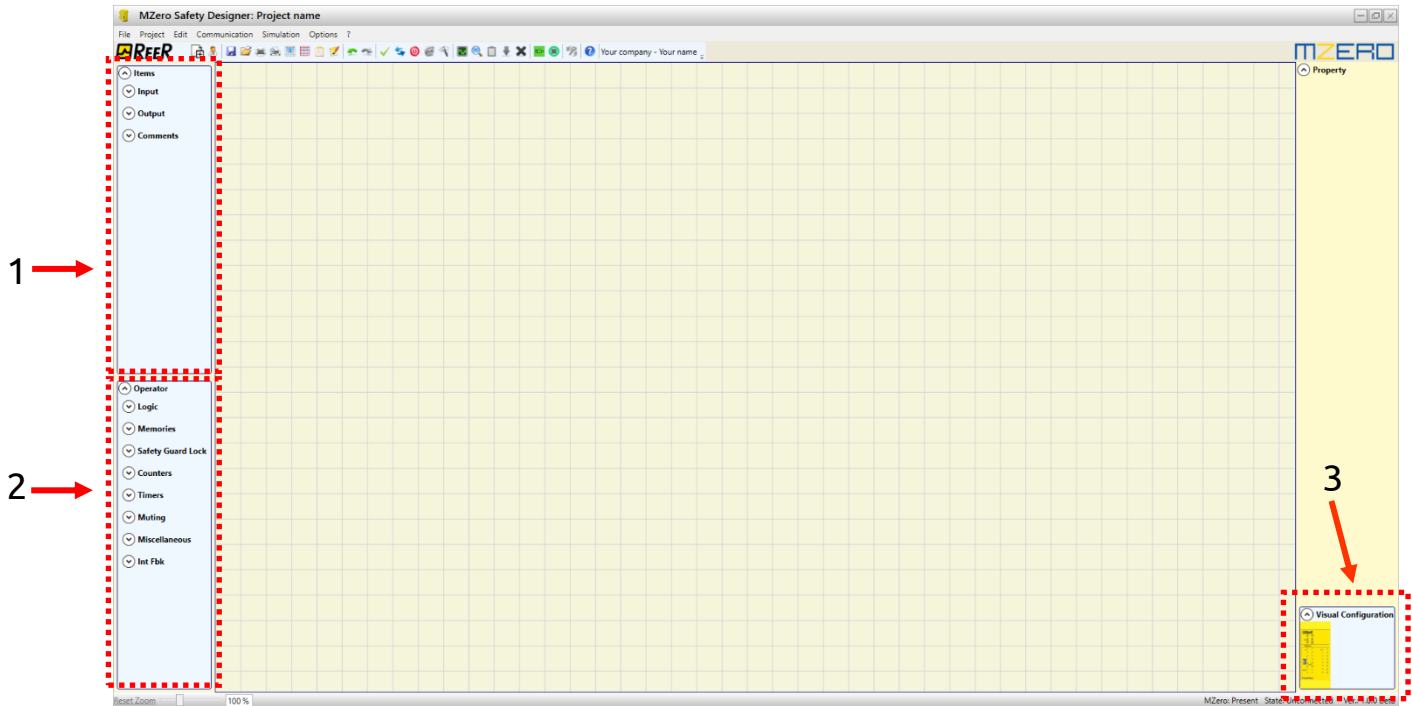

Figure 18

1 > OBJECT TOOL WINDOW

This window contains the various function blocks that will make up your project; these blocks are divided into three different types:

- Inputs
- Outputs
- Comments

2 > OPERATOR TOOL WINDOW

This window contains the various function blocks for connecting the objects in point 1; these blocks are divided into eight different types:

- Logic
- Memories
- Safety Guard Lock
- Counters
- Timers
- Muting
- Miscellaneous
- Int Fbk

3 > CONFIGURATION TOOL WINDOW (view)

This window contains the graphic representation of your MZERO composition.

Creating the diagram

Once you have selected your system composition, you are ready to configure the project.

The logic diagram is created using a **DRAG&DROP** function:

- Select the objects as required from the windows described previously (each single object is described in detail in the following sections) and drag it into the design area.
- Now when you select the object the **PROPERTIES** window is enabled, where you must fill in the fields as required.
- When you need to set a specific numerical value with a slide (eg filter) use the left and right arrows on your keyboard or click the sides of the slider.
- Connect the objects by moving the mouse over the required pin and then dragging it onto the pin to be connected.
- If the scheme requires the PAN function (moving working area in the window), select the object to move and use the arrow keys on your keyboard.
- If the scheme is very complicated and requires a connection between two elements very far, use the "Interpage" component. The element "Interpage out" must have a name which, invoked by the corresponding "Interpage in", allows the desired link.

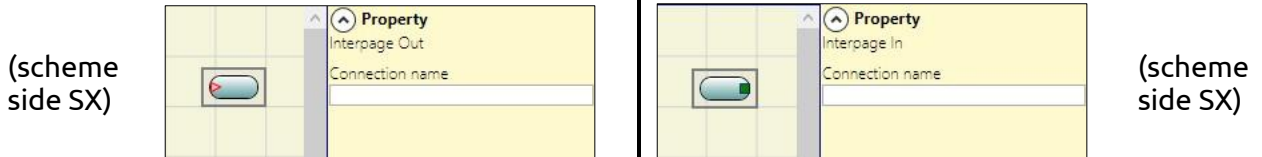

- When you need to duplicate an object, select it and press CTRL+C / CTRL+V keys on your keyboard or click at the right mouse button and select context menu "Copy" and then "Paste".
- Wires position: it is possible to move the wires for a better graphic visibility of the scheme. To activate the function, simply place the mouse pointer and left click on the wire to be moved.

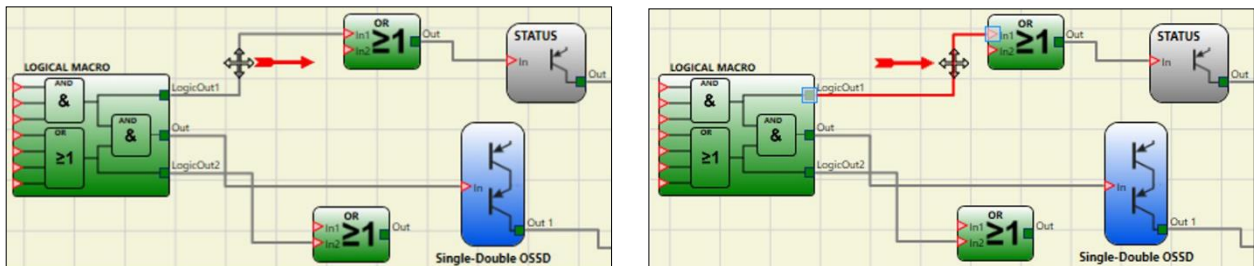

- When you need to delete an object or a link, select it and press DEL key on your keyboard.
- Find function: (press CTRL + F) allows you to make search within the scheme based on a search parameter. Research does not distinguish among upper and lower case.

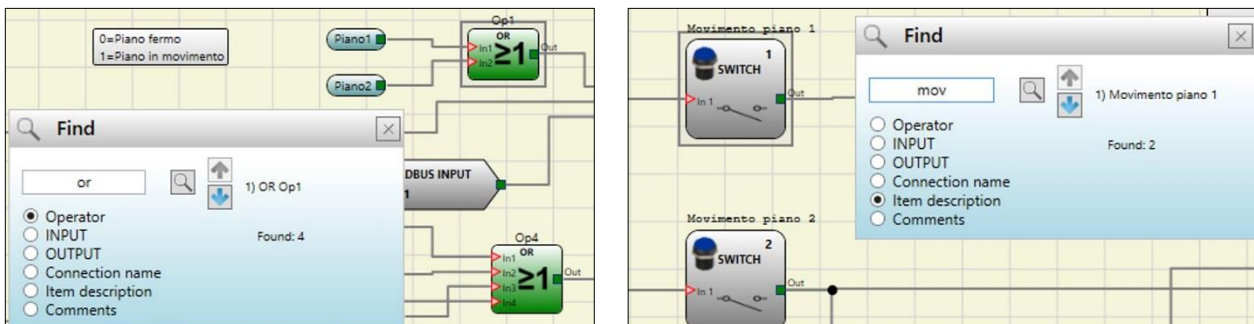

Find Operator

Find item description

USE OF MOUSE RIGHT BUTTON

ON BLOCK INPUT / OUTPUT

- Copy / Paste
- Delete
- Delete all the assigned pins
- Alignment with other functional blocks (multiple selection)
- On-line Help
- Monitor Mode: Show / Hide Properties window
- The block Status: pin input enable / disable logical negation

ON BLOCK OPERATORS

- Copy / Paste
- Delete
- Alignment with other functional blocks (multiple selection)
- On-line Help
- On input pin: activate / deactivate logical negation
- Monitor Mode: Show / Hide Properties window

ON TERMINALS

- Alignment with other blocks

ON CONNECTION (WIRES)

- Delete
- Display full path of the connection (network)

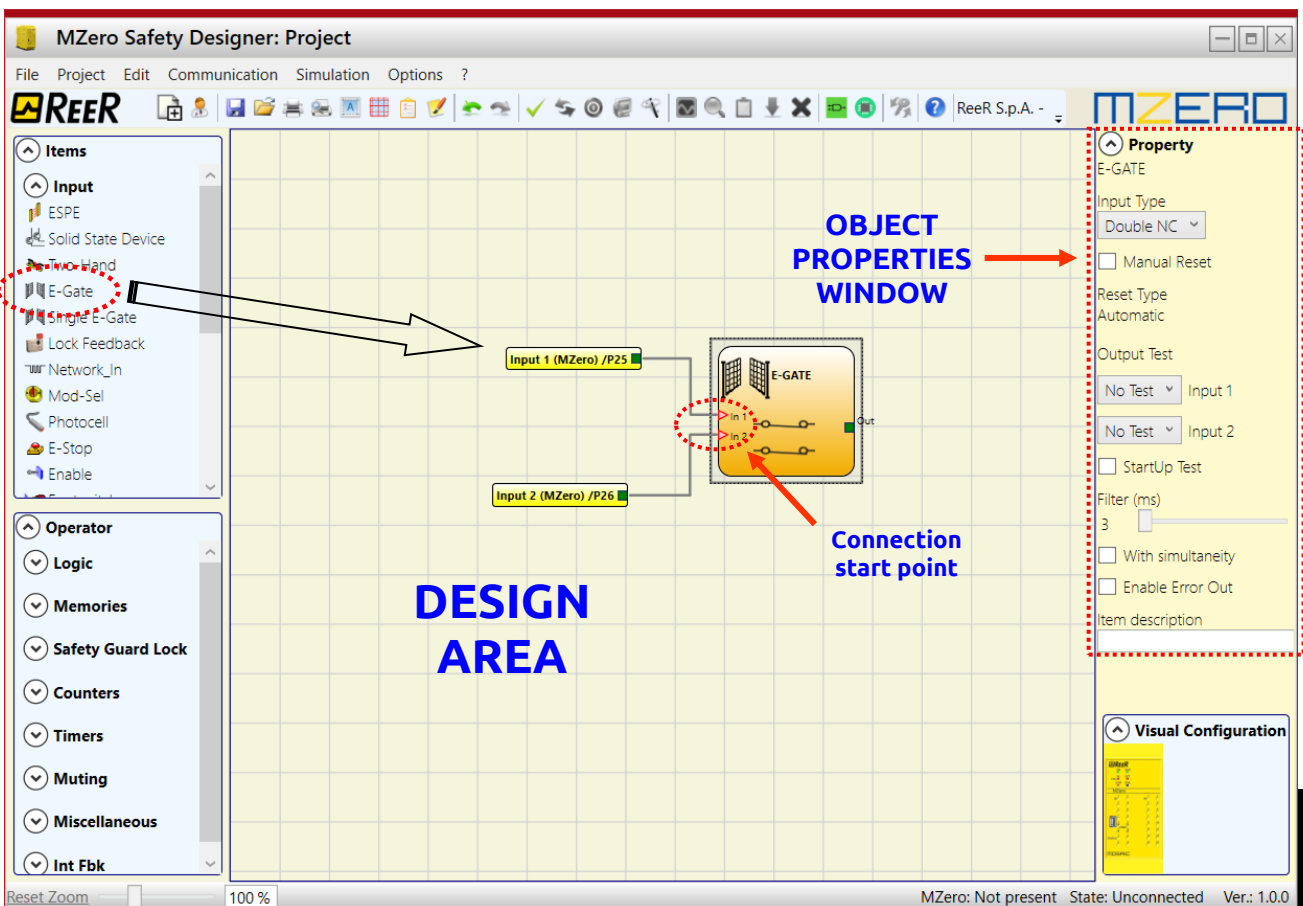

Figure 19

Example of a project

Figure 20 shows an example of a project in which the MZERO controller is connected to two safety blocks (E-GATE and E-STOP).

- MZERO inputs (1,2,3) for connecting the contacts of the safety components are shown on the left, in yellow.
- MZERO outputs (from 1 to 2) are activated according to the conditions defined in E-GATE and E-STOP (see the *E-GATE - E-STOP* sections).

By clicking on a block to select it, you enable the PROPERTIES WINDOW on the right, which you can use to configure the block activation and test parameters (see the *E-GATE - E-STOP* sections).

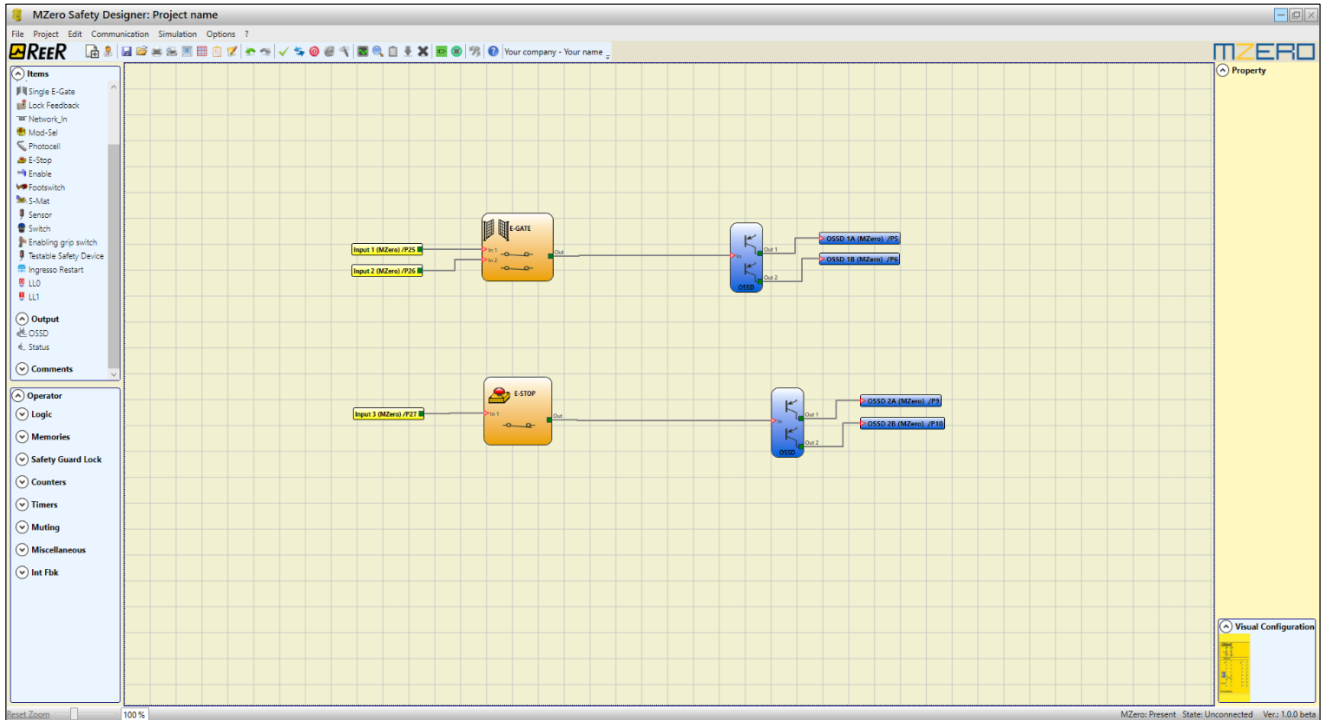



Figure 20

- At the end of the project design stage (or at intermediate steps) you can save the current configuration using the icon SAVE  on the standard tool bar.

Project validation

➔ Now the finished project must be verified. Execute the VALIDATE command (Icon  on the standard toolbar).

If the validation is successful, a sequential number is assigned to the input and output of the project. Then, this number is also listed in the REPORT and in the MONITOR of MZD.

Only if the validation is successful we will proceed to send the configuration.

 The validation function only verifies the consistency of programming with respect to the characteristics of the MZERO system. It does not guarantee that the device has been programmed to meet all the safety requirements for the application.

Resources Allocation

To activate the RESOURCES ALLOCATION function use the icon .

Executing this command, all the used elements among Inputs, OSSD Outputs, Status are visible, see the example in figure.

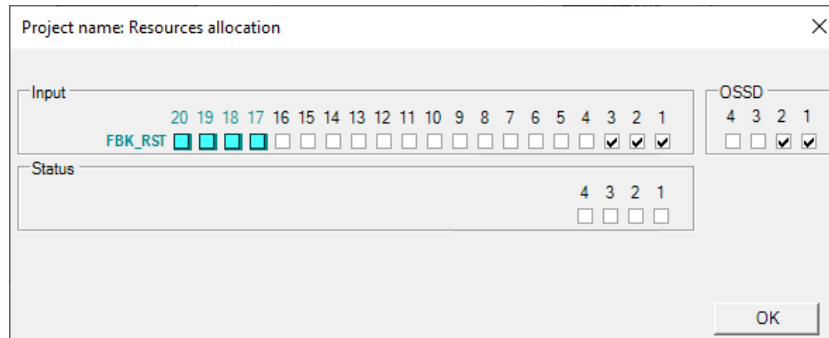

Figure 21

Project report

Print of the System composition with properties of each block. (Icon  on the standard toolbar).

MZERO**REER**

MZero stand alone programmable safety controller

Project Report generated by MZero
Safety Designer Ver.: 1.0.0

1. [Project Report](#)
2. [Cycle Time](#)
3. [Safety Information](#)
4. [Resources used](#)
5. [Electrical diagram](#)

MZero: Project Report

Project Name: Project
User: MZero
Company: Reer S.p.A.
Date: 09/11/2020 13:51:08
Schematic CRC:: F9C7
File Name: C:\Project.m0x

MZero: Cycle Time

Cycle Time (ms) = 4,72

MZero: Safety Information

PFHd (according to IEC 61508): 0,00E+000 (1/h)
MTTFd (according to EN ISO 13849-1): 2500 years
DCavg (according to EN ISO 13849-1): NaN

Attention!

This definition of PL and of the other related parameters as set forth in EN ISO 13849-1 only refers to the functions implemented in the MZero system by the MSD configuration software, assuming configuration has been performed correctly. The actual PL of the entire application and the relative parameters must consider data for all the devices connected to the MZero system within the scope of the application. This task and any other aspect of system configuration are the exclusive responsibility of the user/installer. The final MTTFd value, taking in account data for all the devices connected to the system, must always be saturated to 100 years if over.

1/3

Figure 22

MZero: Resources used

INPUT	11/16	69 %
Total number blocks	3/64	5 %
OSSD	3/4	75 %
STATUS	2/4	50 %

MZero: Electrical diagram

Function Block 01 Enable ▼

Lista Blocchi Funzionali

	Function Block 01 Enable	Filter (ms): 3 Single Reset Type: Automatic StartUp Test: False	Connections: In1: MZero 1/Terminal25
	Function Block 02 E-Stop	Filter (ms): 3 Single Reset Type: Automatic StartUp Test: False	Connections: In1: MZero 2/Terminal26
	Function Block 03 Single E-Gate	Filter (ms): 3 Reset Type: Automatic StartUp Test: False	Connections: In1: MZero 3/Terminal27
	Function Block 04 Photocell	Filter (ms): 3 DC = 90% (according to EN ISO 13849-1) Reset Type: Automatic StartUp Test: False	Connections: In1: MZero 4/Terminal28 Test: In1 -> MZero T1/Terminal21
	Function Block 05 Footswitch	Filter (ms): 3 Reset Type: Automatic StartUp Test: False Single NC	Connections: MZero 5/Terminal29 Test: In1 -> MZero T2/Terminal22
	Function Block 06 Switch	Filter (ms): 3 Reset Type: Automatic StartUp Test: False	Connections: In1: MZero 6/Terminal30
	Function Block 07 Testable Safety Device	Filter (ms): 3 Single NC Reset Type: Automatic StartUp Test: False	Connections: In1: MZero 7/Terminal31

2/3

Figure 23

	<p>Function Block 08 Enabling grip switch</p>	<p>Filter (ms): 3 Simultaneity (ms): 200 Double NO DC = 90% (according to EN ISO 13849-1) Reset Type: Automatic StartUp Test: False</p>	<p>Connections: In1: MZero 8/Terminal32 In2: MZero 9/Terminal33</p>
	<p>Function Block 09 Sensor</p>	<p>Filter (ms): 3 Reset Type: Automatic StartUp Test: False</p>	<p>Connections: In1: MZero 10/Terminal34 Test: In1 -> MZero T2/Terminal22</p>
	<p>Function Block 10 Lock Feedback</p>	<p>Filter (ms): 3 Single NC Reset Type: Automatic StartUp Test: False</p>	<p>Connections: In1: MZero 11/Terminal35</p>
	<p>Op01 Or</p>	<p>Connections: 2</p>	
	<p>Op02 NAnd</p>		
	<p>Op03 Logical Macro</p>	<p>And (3) Or (2) And</p>	
	<p>OUTPUT 01 OSSD SIL3/PL e</p>	<p>Reset Type: Manual Response time: 17,31 ms Dependence on inputs : <u>1</u></p>	<p>Connections: MZero OSSD1A/Terminal5 MZero OSSD1B/Terminal6 MZero Restart_Fbk: Terminal7</p>
	<p>OUTPUT 02 OSSD SIL3/PL e</p>	<p>Reset Type: Manual Response time: 17,31 ms Dependence on inputs : <u>1</u></p>	<p>Connections: MZero OSSD2A/Terminal9 MZero OSSD2B/Terminal10 MZero Restart_Fbk: Terminal11</p>
	<p>OUTPUT 03 OSSD SIL3/PL e</p>	<p>Reset Type: Automatic Response time: 17,31 ms Dependence on inputs : <u>6 ; 7 ; 8 ; 9 ; 10</u></p>	<p>Connections: MZero OSSD3A/Terminal13 MZero OSSD3B/Terminal14</p>
	<p>Status 01 SIL1/PL c</p>	<p>Connections: MZero Terminal8</p>	
	<p>Status 02 SIL1/PL c</p>	<p>Connections: MZero Terminal12</p>	

Signature _____

Figure 24

- ✦ This definition of PL and of the other related parameters as set forth in ISO 13849-1 only refers to the functions implemented in the MZERO system by the MZD configuration software, assuming configuration has been performed correctly.
- ✦ The actual PL of the entire application and the relative parameters must consider data for all the devices connected to the MZERO system within the scope of the application.
- ✦ This must only be performed by the user/installer.

Connect to MZERO

After connecting MZERO to the PC via CSU cable (USB) use the icon  for the connection. A window appears to request the password. Enter the password (see "Password protection").

- ➔ With the eye "visible/not visible" icon you can select to see/hide the entered password.
- ➔ If a remote connection (via internet) is needed MZERO can connect to the appropriate devices through its USB port.
- ➔ In this case select "Remote connection".

Select here if the connection is from a PC **not** directly connected to MZERO via USB (remote connection)



Figure 25

Sending the configuration to MZERO

To send the saved configuration from a PC to MZERO use the icon  on the standard toolbar and wait the execution. MZERO will save the project in its internal memory. (Password Required: level 2).

- ➔ This function is possible only after project validation with OK result.

Download a configuration file (project) from MZERO

To download a project from MZERO to MZD use the icon  on the Standard toolbar. MZD will display the project residing in MZERO. (Level 1 password is enough).

- ➔ If the project must be used on other MZERO system perform a "Project Validation" (page 30) and a "Testing the System" (page 40).

Configuration LOG

- ➔ Within the configuration file (project), are included the **creation date** and **CRC (4-digit hexadecimal identification)** of a project that are stored in MZERO.
- ➔ This logbook can record up to 5 consecutive events, after which these are overwritten, starting from the least recent event.

The log file can be visualized using the icon  in the standard tool bar. (Password Required: level 1).

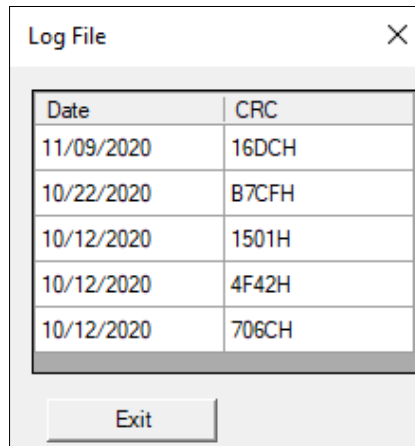

Date	CRC
11/09/2020	16DCH
10/22/2020	B7CFH
10/12/2020	1501H
10/12/2020	4F42H
10/12/2020	706CH

Exit

Figure 26

Disconnecting System

To disconnect the PC from MZERO use the icon  ; when the system is disconnected it is resetted and it starts with the sent project.

MONITOR (I/O status in real time - textual)

To activate the MONITOR function use the icon . (Password Required: level 1). A pop-up window will appear with (all in real time):

- input's state (when the object has two or more input connections to MZERO, the MONITOR will show as active only the first), see the example in figure;
- Input's/Out_test Diagnostics;
- OSSD's State;
- OSSD's Diagnostics;
- Signaling OUTPUT's state;

Monitor
- □ ×

MZero

INPUT

#	Block	Notes	Terminal	State	Diagnostic
1	1	Enable	IN1	OFF	
2	2	ESPE	IN2	OFF	
3			IN3		
4	3	Solid State Device	IN4	OFF	
5			IN5		
6	4	Two-Hand	IN6	OFF	
7			IN7		
8	5	E-Gate	IN8	OFF	
9			IN9		
10	6	Photocell	IN10	OFF	
11	7	E-Stop	IN11	OFF	
12	8	Enable	IN12	OFF	
13	9	S-Mat	IN13	OFF	S-MAT disconnected
14			IN14		
15	10	Sensor	IN15	OFF	
16	11	Switch	IN16	OFF	

RESTART INPUT

#	Terminal	State	Diagnostic
1	X		
2	Restart Input2	OFF	
3	X		
4	X		

OSSD

#	Terminal	State	Diagnostic
1	OSSD1	OFF	
2	OSSD2	OFF	
3	X		
4	X		

STATUS

#	Terminal	State	Diagnostic
1	STATUS1	OFF	
2	STATUS2	OFF	
3	STATUS3	OFF	
4	X		

Figure 27 - textual monitor

MONITOR (I/O status in real time - textual - graphic)

To activate/deactivate the monitor use the icon . (Password Required: level 1).
 The color of links (Figure 33) allows you to view the diagnostics (**in real time**) with:

- RED** = OFF
- GREEN** = ON
- DASHED ORANGE** = Connection Error
- DASHED RED** = Pending enable (for example RESTART)

➔ Placing the mouse pointer over the link, you can display the diagnostics.

PARTICULAR CASES

- ➔ NETWORK OPERATOR, signals NETWORK IN, OUT:
 - RED CONTINUOUS LINE** = STOP
 - GREEN CONTINUOUS LINE** = RUN
 - ORANGE CONTINUOUS LINE** = START
- ➔ SERIAL OUTPUT OPERATOR:
 - BLACK CONTINUOUS LINE** = data in transmission

The schematic cannot be changed during the monitor. It is possible to display the parameters of a component by clicking on it with the right mouse button, choosing "Show/Hide Properties".

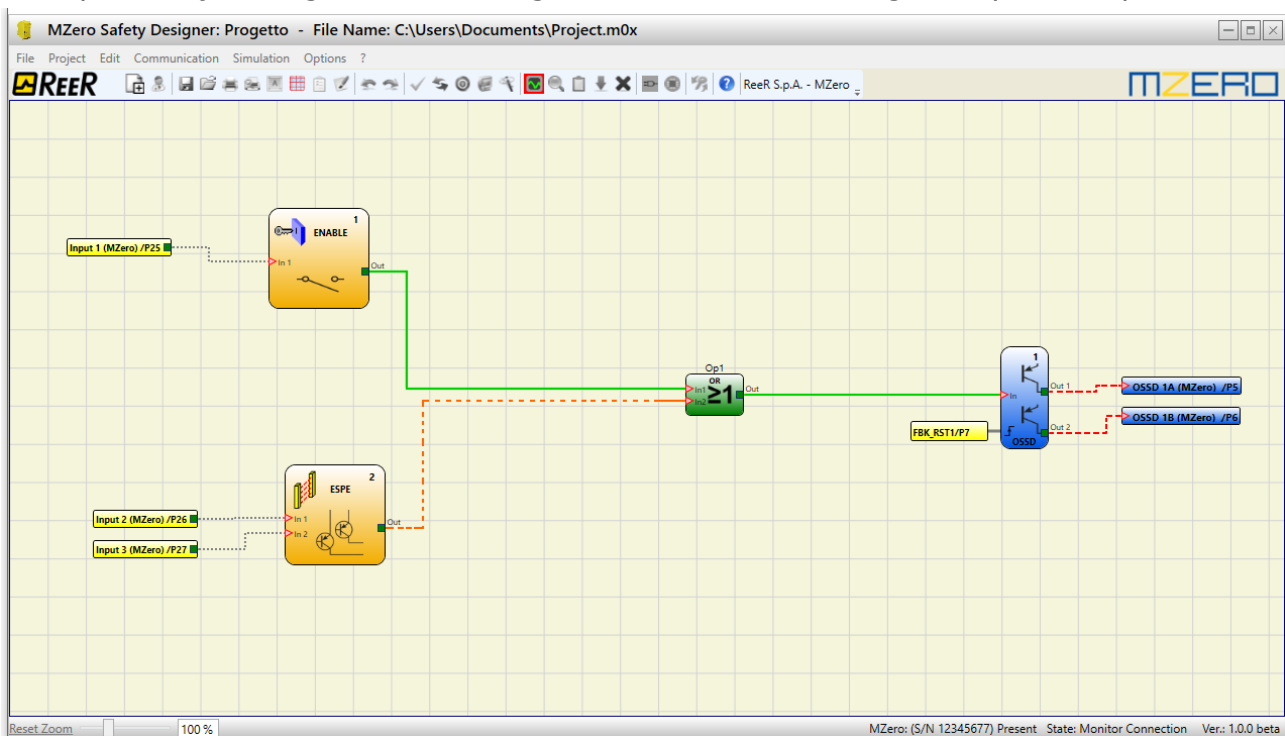

Figure 28 - graphical monitor

Password protection

The MZD requests a password in order to upload and save the project.

➔ The password entered as default must be modified to avoid manipulation (level 2 password) or so that the configuration loaded on MZERO (level 1 password) is not visible.

Level 1 password

All operators using the MZERO system must have a Level 1 PASSWORD.

This password allows only to view the configuration and error LOGs, composition of the system and MONITOR in real time and upload operations.

For the first time the password is "" (ENTER key).

Designers who know the level 2 password can enter a new level 1 password (alphanumerical, max 8 characters).

➔ Operators who know this password **are enabled** to upload (from MZERO to PC), the project.

Level 2 password

Designers authorised to work on the creation of the project must know a Level 2 PASSWORD. The first time the system is initialised the operator must use the password "**SAFEPASS**" (all capital letters).

Designers who know the level 2 password can enter a new level 2 password (alphanumerical, max 8 characters).

With the Level 2 password, the designers authorized has available all the functions of Level plus the ability to download the project from PC to MZERO and change the passwords.

➔ This password **enables** the project to be uploaded (from PC to MZERO), modified and saved. In other words, it allows total control of the PC => MZERO system.

➔ When a new project is UPLOADED the level 2 password could be changed.

➔ Should you forget either of these passwords, please contact ReeR which will provide an unlock file (when the unlock file is saved in the right directory the icon  will appear on the toolbar). When the icon is activated, the password level 1 and level 2 are restored to their original values. This password is only given to the designer and can only be used once.

Password Change

To activate the PASSWORD Change use icon , after connecting with Level 2 Password.

A window appears (Figure 29) allowing the choice of the new password; insert the old and new passwords in the appropriate fields (max 8 characters). Click OK.

At the end of the operation disconnect to restart the system.



Figure 29

TESTING the system

After validating and uploading the project to the MZERO and connecting all the safety devices, you must test the system to verify its correct operation.

- This is done by forcing a change of status for each safety device connected to the MZERO to check that the status of the outputs actually changes.
- The following example is helpful for understanding the TEST procedure.

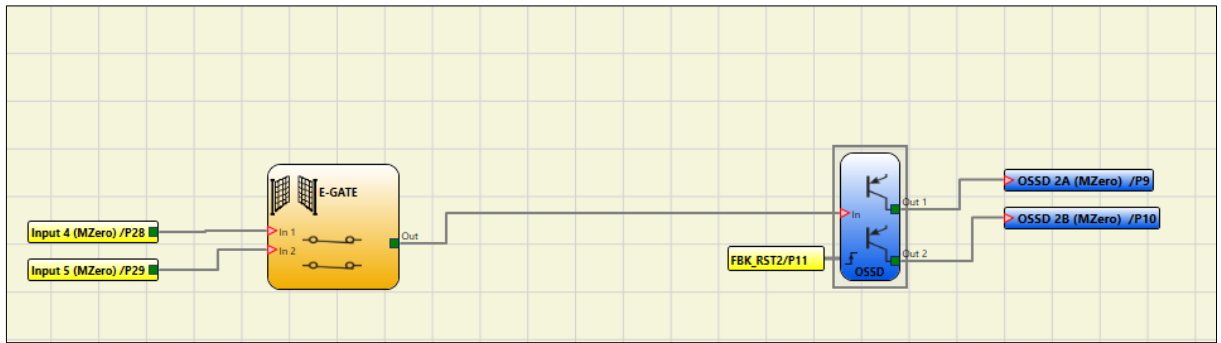

Figure 30

(t1) In the normal operating condition (E-GATE closed) Input1 is closed, Input2 is open and the output of the E-GATE block is set to high logic level; in this mode the safety outputs (OSSD1/2) are active and the power supply to the relative terminals is 24VDC.

(t2) When the E-GATE is **physically** opened, the condition of the inputs and thus of the outputs of the E-GATE block will change: (OUT= 0VDC--->24VDC); **the condition of the OSSD1-OSSD2 safety outputs will change from 24VDC to 0VDC**. If this change is detected the mobile E-GATE is connected correctly.

In1	24vdc		0vdc
In2	0vdc		24vdc
OUT	24vdc		
OSSD1	24vdc		0vdc

For the correct installation of each external sensor/component refer to their installation manual.

This test must be performed for each safety component in the project.

OBJECT FUNCTION BLOCKS

OUTPUT OBJECTS

OSSD (safety outputs)

OSSD safety outputs use semiconductor technology, if the input "In" is at logic level 1 (TRUE) then the "Out1" and "Out2" will be set at 24 VDC (module power supply). If the input "In" is at logic level 0 (FALSE) then the "Out1" and "Out2" will be set at 0 VDC.

➔ Each pair of OSSD outputs has a relative RESTART_FBK input.

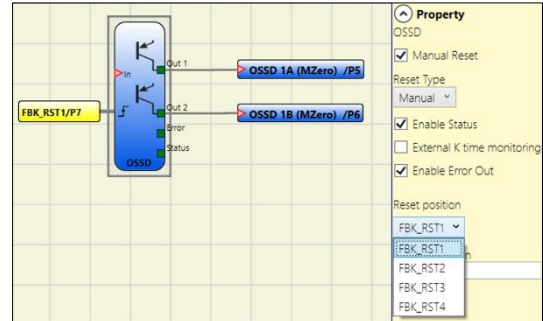

Parameters

Manual Reset: If selected this enables the request to reset each time the input signal falls. Otherwise, output Follows directly In input Signal level.

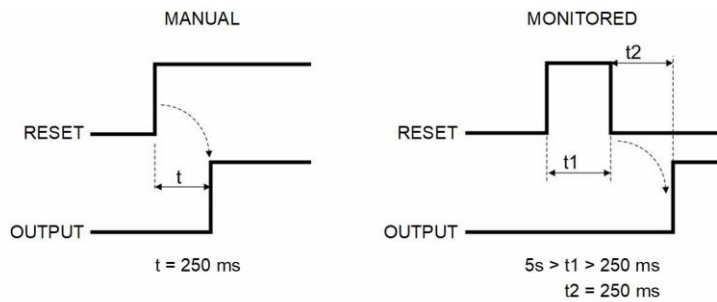

There are two types of reset: Manual and Monitored. In selecting the Manual option only signal transition from 0 to 1 is verified. If the Monitored option is selected, the double transition from 0 to 1 and back to 0 is verified.

Enable Status: If selected, enables the connection of the current OSSD state to any point on the schematic.

External K time monitoring: If selected, enables the setting of the time window within which the external feedback signal is to be monitored (according to following output conditions).

OUTPUT	FBK	ERROR	MZERO OSSD LED
1	0	0	0
0	1	1	Flashing

With high level (TRUE) OUTPUT, the FBK signal must be at low level (FALSE) within the set time. Otherwise, OUTPUT is set to low level (FALSE) and the error is indicated on the MZERO by the flashing OSSD LED corresponding to the OSSD in error.

Reset position: allows to select the physical terminal of MZERO to give the reset command. You can also use the same terminal for different OSSD outputs.

Enable Error Out If selected, enables the ERROR OUT output. **This output is set to high level (TRUE) when an external FBK error is detected.**

The **Error Out** signal is reset in case of one of the following events:

1. Switching on and switching off of system.
2. Activation of the RESET MZERO operator.

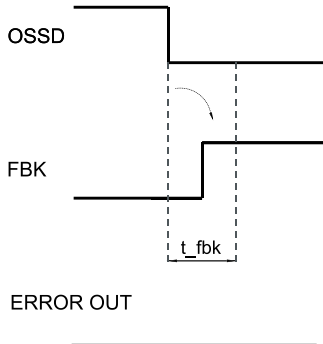

Example of OSSD with correct Feedback signal:
In this case **ERROR OUT=FALSE**

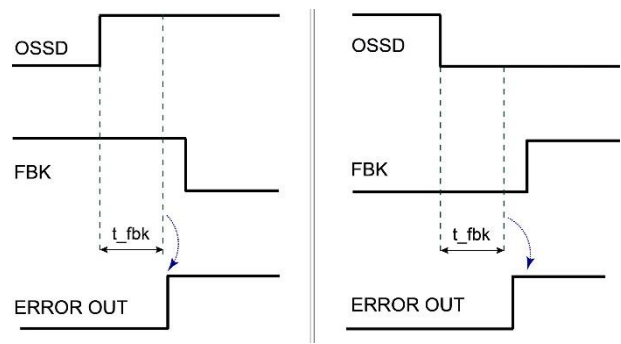

Example of OSSD with incorrect Feedback signal (k external time exceeded):
In this case **ERROR OUT=TRUE**

STATUS (SIL 1/PL c output)

STATUS output (SIL 1/PL c output) makes it possible to monitor any point on the diagram by connecting it to the input.

The output is set at 24Vdc if the input is 1 (TRUE), or it is set at 0Vdc if the input is 0 (FALSE).

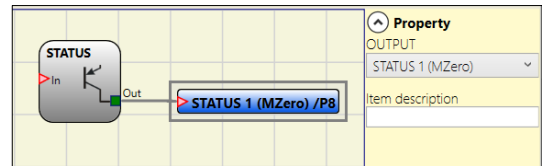

The STATUS output attains only the SIL 1/PL c safety level.

INPUT OBJECTS

E-STOP (emergency stop)

E-STOP function block verifies an emergency stop device inputs status. If the emergency stop button has been pressed the output is 0 (FALSE). If not the output is 1 (TRUE).

Parameters

Input type:

- Single NC – allows connection of one-way emergency stops
- Double NC – allows connection of two-way emergency stops.

Manual reset: If selected this enables the request to reset each time the emergency stop is activated. Otherwise, enabling of the output directly follows the input conditions. There are two types of reset: Manual and Monitored. When Manual is selected the system only verifies the signal's transition from 0 to 1. If Monitored is selected the double transition from 0 to 1 and then back to 0 is verified.

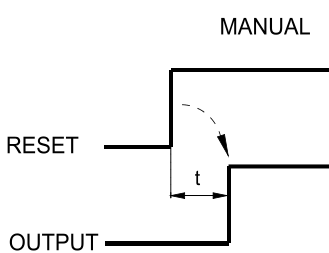
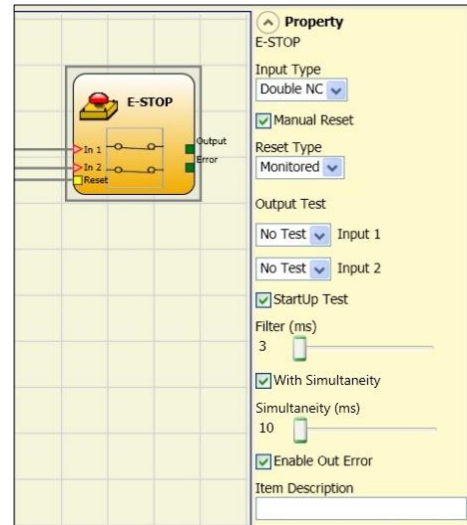

$t = 250\text{ms}$

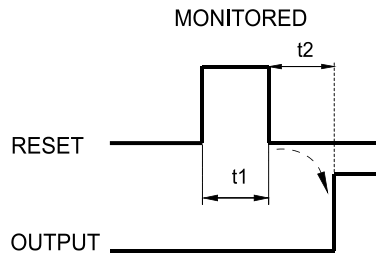

$t1 > 250\text{ms}$
 $t2 = 250\text{ms}$

CONNECTION SAMPLE (1 CONTACT)

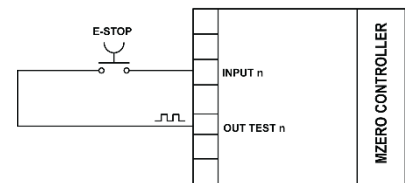

CONNECTION SAMPLE (2 CONTACTS)

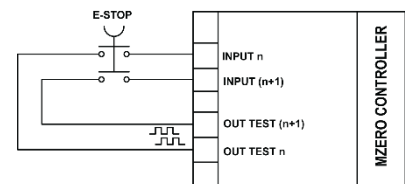

➔ If the Manual Reset is active, a consecutive Input have to be used. Example: Input 1 and Input 2 are used for the functional block, then Input 3 have to be used for the Reset Input.

Output test: This is used to select which test output signals are to be sent to the emergency stop (mushroom pushbutton). This additional test makes it possible to detect and manage any short-circuits between the lines. This additional control permits detection and management of any short-circuits between the lines. To enable this control, the test output signals must be configured (amongst those available).

Test at start-up: If selected this enables the test at start-up of the external component (emergency stop). This test is performed by pressing and releasing the pushbutton to run a complete function test and enable the output. This test is only requested at machine start-up (when the unit is switched on).

Filter (ms): This is used to filter the signals coming from the emergency stop. The filter can be configured to between 3 and 250 ms and eliminates any bouncing on the contacts. The length of the filter affects the calculation of the unit's total response time.

With Simultaneity (only with Double_NC Input type): If selected this activates the test to verify concurrent switching of the signals coming from the emergency stop.

Simultaneity (only with Double_NC Input type) (ms): This is only active if the previous parameter is enabled. It defines the maximum time (in ms) between the switching of two different signals from the emergency stop.

Enable Error Out: If selected reports a fault detected by the function block.

Item description: This allows a description of the component's function to be entered. The text is displayed in the top part of the symbol.

E-GATE (safety gate device)

E-GATE function block verifies a mobile guard or safety gate device input status. If the mobile guard or safety gate is open, the output is 0 (FALSE). Otherwise the output is 1 (TRUE).

Parameters

Input type:

- Double NC – Allows connection of components with two NC contacts
- Double NC/NO – Allows connection of components with one NO contact and one NC.

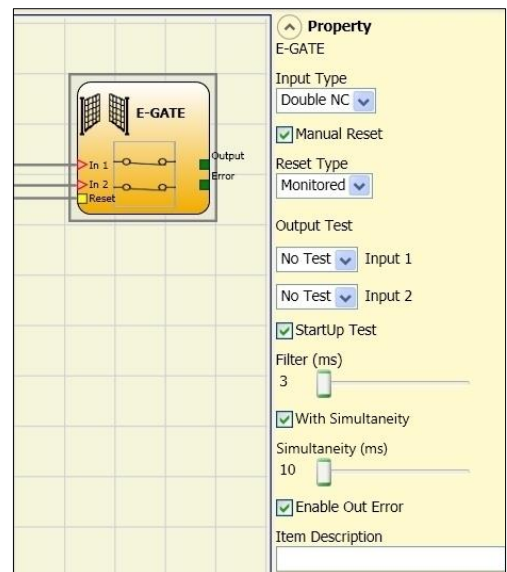

➔ With inactive input (block with Output FALSE), connect:

- Contact NO to terminal corresponding to IN1.
- Contact NC to terminal corresponding to IN2.

Enable reset: If selected this enables the request to reset each time the mobile guard/safety gate is activated. Otherwise, enabling of the output directly follows the input conditions.

There are two types of reset: Manual and Monitored.

When **Manual** is selected the system only verifies the signal's transition from 0 to 1.

If **Monitored** is selected the double transition from 0 to 1 and then back to 0 is verified.

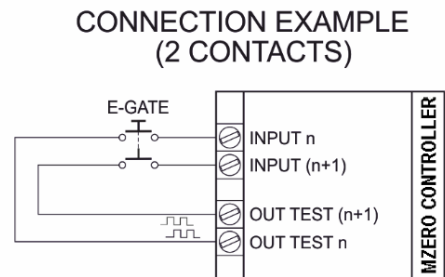
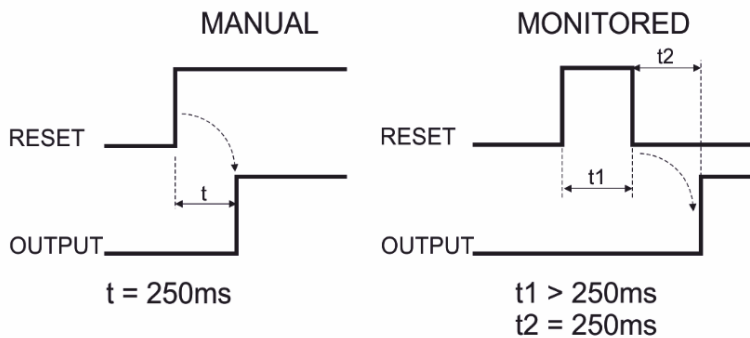

→ If the Manual Reset is active, a consecutive Input have to be used. Example: Input 1 and Input 2 are used for the fuctional block, then Input 3 have to be used for the Reset Input.

Output test: This is used to select which test output signals are to be sent to the component contacts. This additional control permits detection and management of any short-circuits between the lines. To enable this control, the test output signals must be configured (amongst those available).

Test at start-up: If selected this enables the test at start-up of the external component. This test is performed by opening the mobile guard or safety gate to run a complete function test and enable the output. This test is only requested at machine start-up (when the unit is switched on).

Filter (ms): This is used to filter the signals coming from the external contacts. The filter can be configured to between 3 and 250 ms and eliminates any bouncing on the contacts. The length of the filter affects the calculation of the unit's total response time.

With Simultaneity: If selected this activates the test to verify concurrent switching of the signals coming from the external contacts.

Simultaneity (ms): This is only active if the previous parameter is enabled. It defines the maximum time (in ms) between the switching of two different signals from the external contacts.

Enable Error Out: If selected reports a fault detected by the function block.

Item description: This allows a description of the component's function to be entered. The text is displayed in the top part of the symbol.

SINGLE E-GATE (safety gate device)

SINGLE E-GATE function block verifies a mobile guard or safety gate device input status. If the mobile guard or safety gate is open, the output is 0 (FALSE). Otherwise the output is 1 (TRUE).

Parameters

Enable reset: If selected this enables the request to reset each time the mobile guard/safety gate is activated. Otherwise, enabling of the output directly follows the input conditions. There are two types of reset: Manual and Monitored. When **Manual** is selected the system only verifies the signal's transition from 0 to 1.

If **Monitored** is selected the double transition from 0 to 1 and then back to 0 is verified.

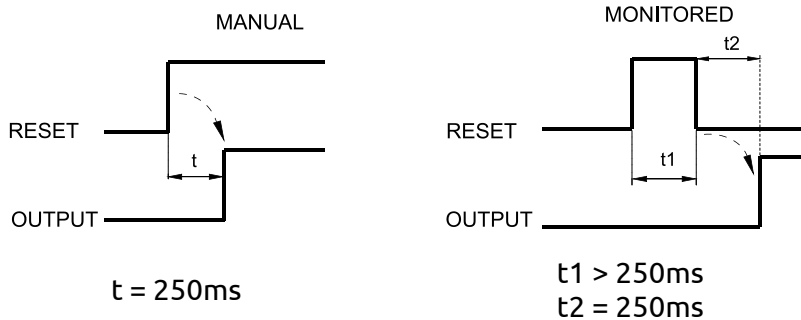
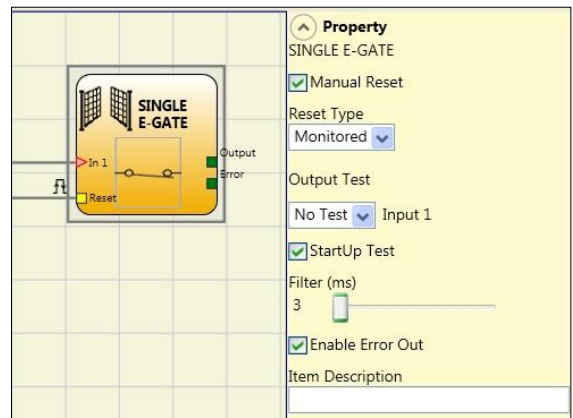

→ If the Manual Reset is active, a consecutive Input have to be used. Example: Input 1 and Input 2 are used for the fuctional block, then Input 3 have to be used for the Reset Input.

Output test: This is used to select which test output signals are to be sent to the component contacts. This additional control permits detection and management of any short-circuits between the lines. To enable this control, the test output signals must be configured (amongst those available).

Test at start-up: If selected this enables the test at start-up of the external component. This test is performed by opening the mobile guard or safety gate to run a complete function test and enable the output. This test is only requested at machine start-up (when the unit is switched on).

Filter (ms): This is used to filter the signals coming from the external contacts. The filter can be configured to between 3 and 250 ms and eliminates any bouncing on the contacts. The length of the filter affects the calculation of the unit's total response time.

Enable Error Out: If selected reports a fault detected by the function block.

Item description: This allows a description of the component's function to be entered. The text is displayed in the top part of the symbol.

LOCK FEEDBACK

The function block LOCK FEEDBACK verifies the lock status of the guard lock device for mobile guard or safety gate. In the case where the inputs indicate that the guard is locked the Output will be 1 (TRUE). Otherwise the output is 0 (FALSE).

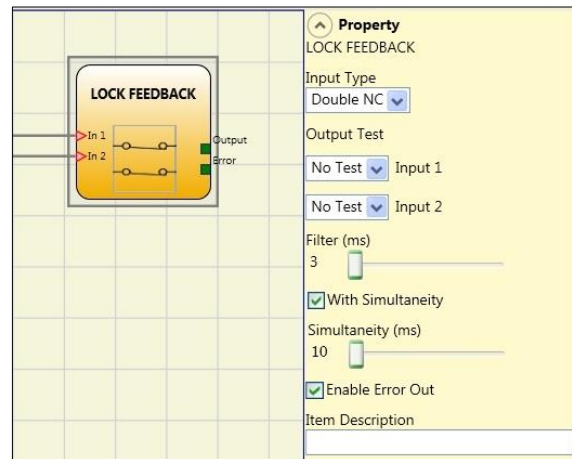

Parameters

Input type

- Single NC – Allows connection of components with one NC contact;
- Double NC – Allows connection of components with two NC contacts.
- Double NC/NO – Allows connection of components with one NO contact and one NC.

- ➔ With inactive input (guard unlocked), connect:
- Contact NO to terminal corresponding to IN1.
 - Contact NC to terminal corresponding to IN2.

Output test: This is used to select which test output signals are to be sent to the component contacts. This additional control permits detection and management of any short-circuits between the lines. To enable this control, the test output signals must be configured (amongst those available).

Filter (ms): This is used to filter the signals coming from the external contacts. The filter can be configured to between 3 and 250 ms and eliminates any bouncing on the contacts. The length of the filter affects the calculation of the unit's total response time.

With Simultaneity (only with Double_NC or Double NC/NO Input type): If selected this activates the test to verify concurrent switching of the signals coming from the external contacts.

Simultaneity (ms) (only with Double_NC or Double NC/NO Input type): This is only active if the previous parameter is enabled. It defines the maximum time (in ms) between the switching of two different signals from the external contacts.

Enable Error Out: If selected reports a fault detected by the function block.

Item description: This allows a description of the component's function to be entered. The text is displayed in the top part of the symbol.

ENABLE (enable key)

ENABLE function block verifies a manual key device Input status. If the key is not turned the output is 0 (FALSE). Otherwise the output is 1 (TRUE).

Parameters

Input type

- Single NO – Allows connection of components with one NO contact;
- Double NO – Allows connection of components with two NO contacts.

Enable reset: If selected this enables the request to reset each time the command is activated. Otherwise, enabling of the output directly follows the input conditions.

There are two types of reset: Manual and Monitored. When **Manual** is selected the system only verifies the signal's transition from 0 to 1.

If **Monitored** is selected the double transition from 0 to 1 and then back to 0 is verified.

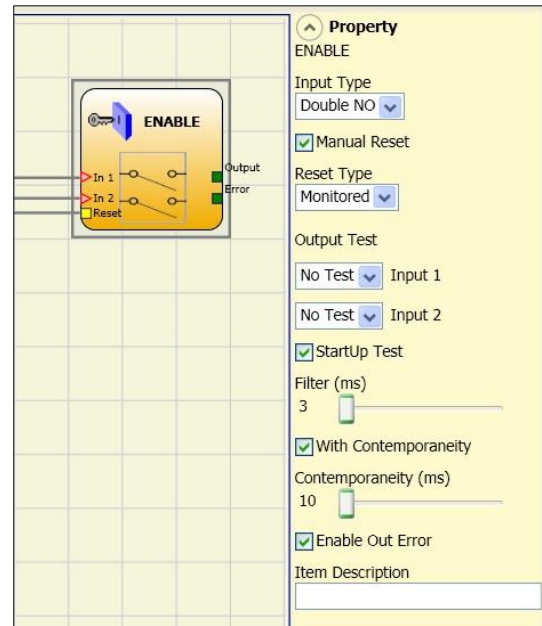

➔ If the Manual Reset is active, a consecutive Input have to be used.
 Example: Input 1 and Input 2 are used for the functional block, then Input 3 have to be used for the Reset Input.

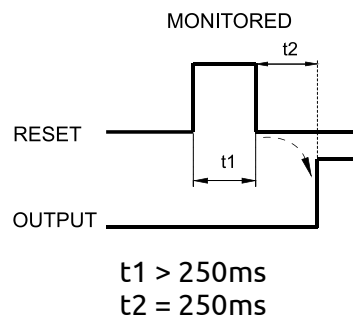
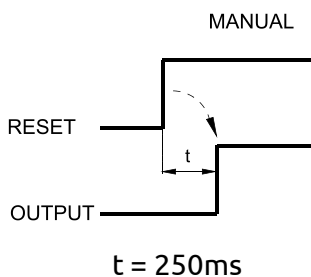
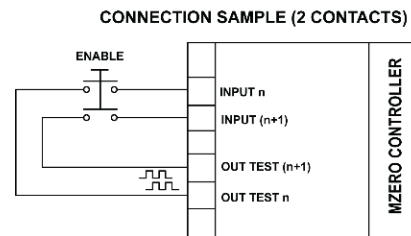
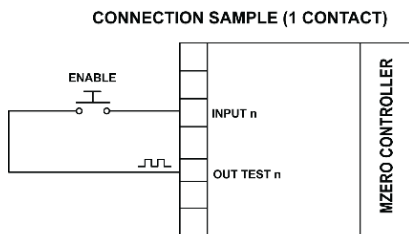

Output test: This is used to select which test output signals are to be sent to the component contacts. This additional control permits detection and management of any short-circuits between the lines. To enable this control, the test output signals must be configured (amongst those available).

Test at start-up: If selected this enables the test at start-up of the external component. This test is performed by opening and activating the enable key to run a complete function test and enable the output. This test is only requested at machine start-up (when the unit is switched on).

Filter (ms): This is used to filter the signals coming from the external contacts. The filter can be configured to between 3 and 250 ms and eliminates any bouncing on the contacts. The length of the filter affects the calculation of the unit's total response time.

With Simultaneity (only with Double NO Input type): If selected this activates the test to verify concurrent switching of the signals coming from the external contacts.

Simultaneity (ms) (only with Double NO Input type): This is only active if the previous parameter is enabled. It defines the maximum time (in ms) between the switching of two different signals from the external contacts.

Enable Error Out: If selected reports a fault detected by the function block.

Item description: This allows a description of the component's function to be entered. The text is displayed in the top part of the symbol.

ESPE (optoelectronic safety light curtain / laser scanner)

ESPE function block verifies an optoelectronic safety light curtain (or laser scanner) inputs state. If the area protected by the light curtain is occupied, (light curtain outputs FALSE) the output is 0 (FALSE). Otherwise, with the area clear and outputs to 1 (TRUE) the output is 1 (TRUE).

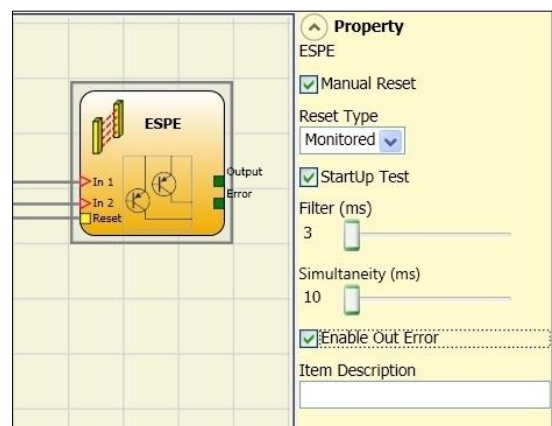

Parameters

Enable reset: If selected this enables the request to reset each time the area protected by the safety light curtain is occupied. Otherwise, enabling of the output directly follows the input conditions.

There are two types of reset: Manual and Monitored.

When **Manual** is selected the system only verifies the signal's transition from 0 to 1.

If **Monitored** is selected the double transition from 0 to 1 and then back to 0 is verified.

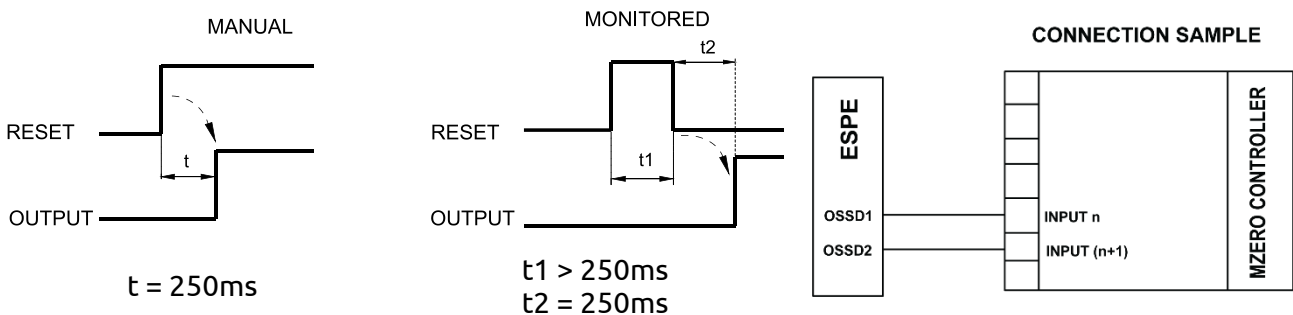

➔ If the Manual Reset is active, a consecutive Input have to be used. Example: Input 1 and Input 2 are used for the functional block, then Input 3 have to be used for the Reset Input.

OUT TEST signals cannot be used in case of safety static output ESPE because the control is carried out from the ESPE.

Test at start-up: If selected this enables the test at start-up of the safety light curtain. This test is performed by occupying and clearing the area protected by the safety light curtain to run a complete function test and enable the output. This test is only requested at machine start-up (when the unit is switched on).

Filter (ms): This is used to filter the signals coming from the safety light curtain. The filter can be configured to between 3 and 250 ms and eliminates any bouncing on the contacts. The length of the filter affects the calculation of the unit's total response time.

Simultaneity (ms): always active. Determines the maximum permissible time (ms) between switching of the various signals from the external contacts of the device.

Enable Error Out: If selected reports a fault detected by the function block.

Item description: This allows a description of the component's function to be entered. The text is displayed in the top part of the symbol.

FOOTSWITCH (safety pedal)

The FOOTSWITCH function block verifies the status of the inputs of a safety pedal device. If the pedal is not pressed the output is 0 (FALSE). Otherwise the output is 1 (TRUE).

Parameters

Input type:

- Single NC – Allows connection of pedals with one NC contact
- Single NO – Allows connection of pedals with one NO contact.
- Double NC – Allows connection of pedals with two NC contacts
- Double NC/NO – Allows connection of pedals with one NO contact and one NC.

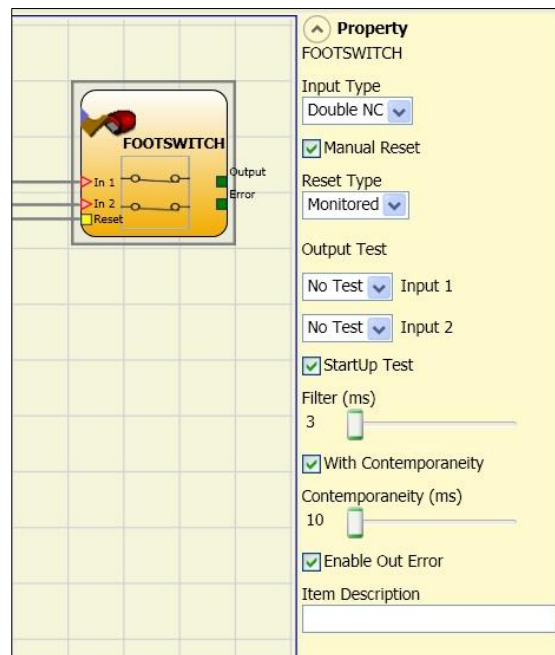

Double NC/NO correct connection

- Contact NC to terminal corresponding to IN1
- Contact NO to terminal corresponding to IN2

Manual reset: If selected this enables the request to reset each time the safety pedal is activated. Otherwise, enabling of the output directly follows the input conditions.

There are two types of reset: Manual and Monitored. When Manual is selected the system only verifies the signal's transition from 0 to 1. If Monitored is selected the double transition from 0 to 1 and then back to 0 is verified.

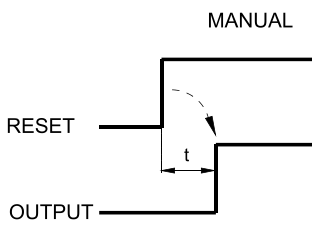

$t = 250\text{ms}$

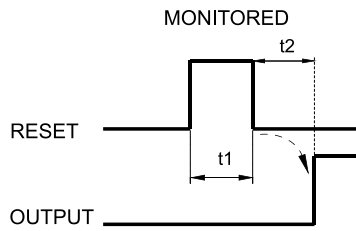

$t1 > 250\text{ms}$
 $t2 = 250\text{ms}$

CONNECTION SAMPLE (1 CONTACT)

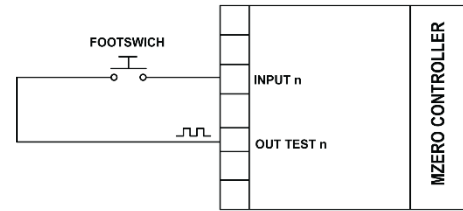

CONNECTION SAMPLE (2 CONTACTS)

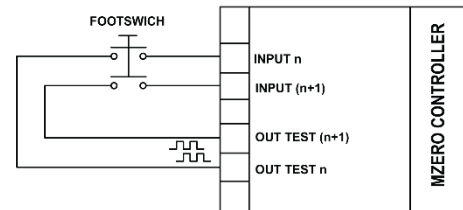

➔ If the Manual Reset is active, a consecutive Input have to be used. Example: Input 1 and Input 2 are used for the functional block, then Input 3 have to be used for the Reset Input.

Output test: This is used to select which test output signals are to be sent to the component contacts. This additional control permits detection and management of any short-circuits between the lines. To enable this control, the test output signals must be configured (amongst those available).

Test at start-up: If selected this enables the test at start-up of the external component. This test is performed by pressing and releasing the footswitch to run a complete function test and enable the output. This test is only requested at machine start-up (when the unit is switched on).

Filter (ms): This is used to filter the signals coming from the external contacts. The filter can be configured to between 3 and 250 ms and eliminates any bouncing on the contacts. The length of the filter affects the calculation of the unit's total response time.

With Simultaneity (only with Double NC or Double NC-NO Input type): If selected this activates the test to verify concurrent switching of the signals coming from the external contacts.

Simultaneity (ms): This is only active if the previous parameter is enabled. It defines the maximum time (in ms) between the switching of two different signals from the external contacts.

Enable Error Out: If selected reports a fault detected by the function block.

Item description: This allows a description of the component's function to be entered. The text is displayed in the top part of the symbol.

MOD-SEL (safety selector)

The MOD-SEL function block verifies the status of the inputs from a mode selector (up to 4 inputs): If only one input is 1 (TRUE) the corresponding output is also 1 (TRUE). In all other cases, and thus when all inputs are 0 (FALSE) or more than one input is 1 (TRUE) all the outputs are 0 (FALSE).

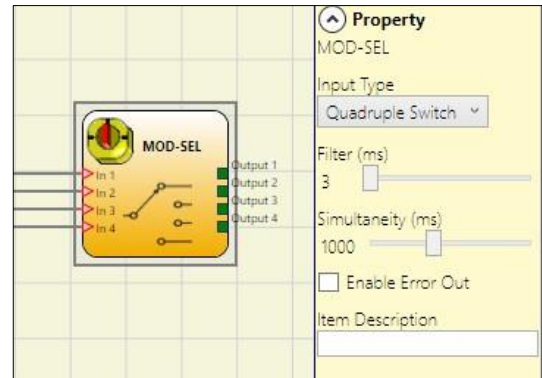

Parameters

Input type:

- Double selector – Allows connection of two-way mode selectors.
- Triple selector – Allows connection of three-way mode selectors.
- Quadruple selector - Allows connection of four-way mode selectors.

Filter (ms): This is used to filter the signals coming from the mode selector. The filter can be configured to between 3 and 250 ms and eliminates any bouncing on the contacts. The length of the filter affects the calculation of the unit's total response time.

Simultaneity (ms): always active. Determines the maximum permissible time (ms) between switching of the various signals from the external contacts of the device.

Enable Error Out: If selected reports a fault detected by the function block.

Item description: This allows a description of the component's function to be entered. The text is displayed in the top part of the symbol.

PHOTOCELL (safety photocell)

The PHOTOCELL function block verifies the status of the inputs of an optoelectronic safety photocell. If the beam of the photocell is occupied (photocell output FALSE) the output is 0 (FALSE). Otherwise with the beam clear and an output of 1 (TRUE) the output is 1 (TRUE).

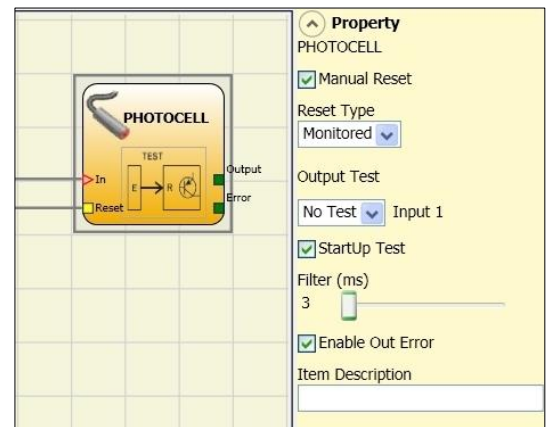

Parameters

Manual reset: If selected this enables the request to reset each time safety photocell is activated. Otherwise, enabling of the output directly follows the input conditions.

There are two types of reset: Manual and Monitored.

When Manual is selected the system only verifies the signal's transition from 0 to 1. If Monitored is selected the double transition from 0 to 1 and then back to 0 is verified.

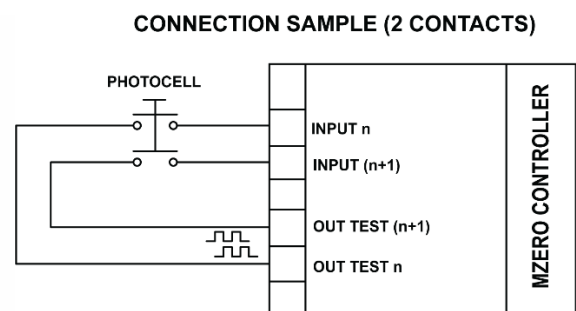
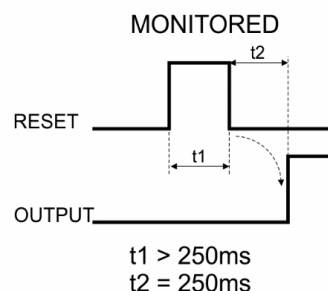
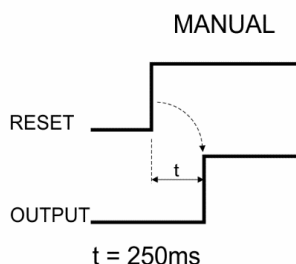

- ➔ An output test signal is mandatory and can be selected from the 4 possible Test Output 1...4.
- ➔ If the Manual Reset is active, a consecutive Input have to be used. Example: Input 1 is used for the functional block, then Input 2 have to be used for the Reset Input.
- ➔ The response time of the photocell must be >2ms and <20ms.

Output test: This is used to select which test output are to be sent to the photocell test input. This additional control permits detection and management of any short-circuits between the lines. To enable this control, the test output signals must be configured (amongst those available).

Test at start-up: If selected this enables the test at start-up of the external component. This test is performed by occupying and clearing the photocell to run a complete function test and enable the output. This test is only requested at machine start-up (when the unit is switched on).

Filter (ms): This is used to filter the signals coming from the external contacts. The filter can be configured to between 3 and 250 ms and eliminates any bouncing on the contacts. The length of the filter affects the calculation of the unit's total response time.

Enable Error Out: If selected reports a fault detected by the function block.

Item description: This allows a description of the component's function to be entered. The text is displayed in the top part of the symbol.

TWO-HAND (bimanual control)

The TWO HAND function block verifies the status of the inputs of a two hand control switch. Only if both the press-buttons are pressed within 500 ms the output is 1 (TRUE). Otherwise the output is 0 (FALSE).

Input type:

- Double NO – Allows connection of two-hand switch with one NO contact for each button (EN 574 III A).
- Quadruple NC-NO - Allows connection of two-hand switch with a double NO/NC contact for each button (EN 574 III C).

Quadruple NC/NO correct connection

- Contacts NO to terminal corresponding to IN1, IN3
- Contacts NC to terminal corresponding to IN2, IN4

Parameters

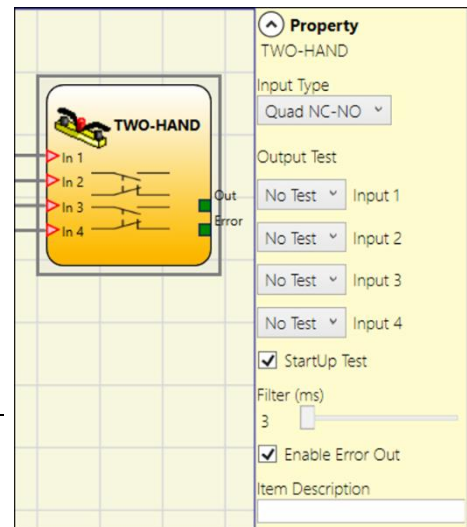

Output test: This is used to select which test output signals are to be sent to the component contacts. This additional control permits detection and management of any short-circuits between the lines. To enable this control, the test output signals must be configured (amongst those available).

Test at start-up: If selected this enables the test at start-up of the external component. This test is performed by pressing the two buttons (within 500 ms) and releasing them to run a complete function test and enable the output. This test is only requested at machine start-up (when the unit is switched on).

Filter (ms): This is used to filter the signals coming from the mode selector. The filter can be configured to between 3 and 250 ms and eliminates any bouncing on the contacts. The length of the filter affects the calculation of the unit's total response time.

Enable Error Out: If selected reports a fault detected by the function block.

Item description: This allows a description of the component's function to be entered. The text is displayed in the top part of the symbol.

NETWORK_IN

This functional block implements a Network connection input interface; it generates an LL1 in the OUT output when the line is high, otherwise an LL0.

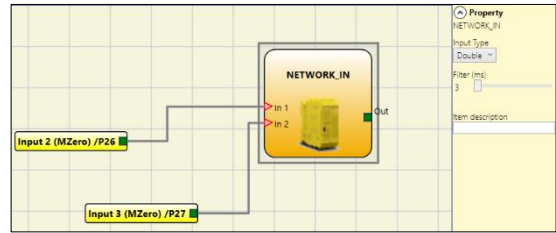

Parameters

Type of input:

- Single - enables the connection of Signalling outputs of an external MZERO unit.
- Double - enables the connection of OSSD outputs of an external MZERO unit.

Filter (ms): Enables the filtering of signals from an external MZERO unit.

This filter can be set to between 3 and 250ms. The length of the filter affects the calculation of the unit's total response time.

➔ This input must be used when MZERO OSSD outputs are connected to the inputs of a second downstream MZERO or together with the NETWORK operator.

SENSOR

The SENSOR function block verifies the status of the input of a sensor (not a safety sensor). If the beam of the sensor is occupied (sensor output FALSE) the output is 0. Otherwise, with the beam clear and an output of 1 (TRUE) then the output is 1.

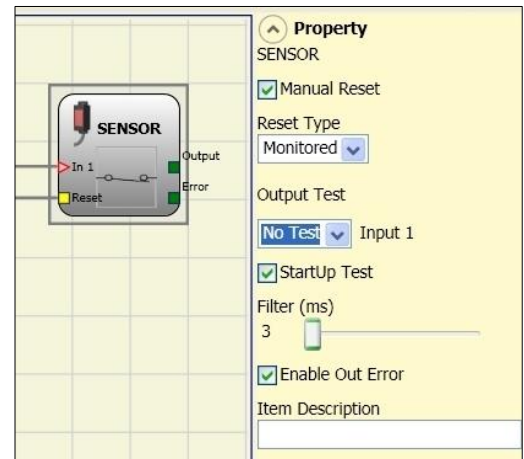

Parameters

Manual reset: If selected this enables the request to reset each time the area protected by the sensor is occupied. Otherwise, enabling of the output directly follows the input conditions.

There are two types of reset: Manual and Monitored. When Manual is selected the system only verifies the signal's transition from 0 to 1. If Monitored is selected the double transition from 0 to 1 and then back to 0 is verified.

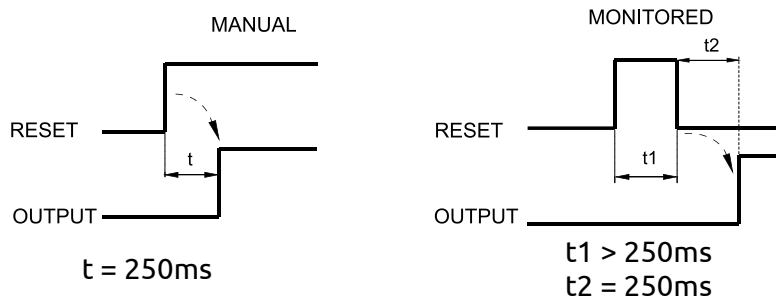

➔ If the Manual Reset is active, a consecutive Input have to be used. Example: Input 1 is used for the functional block, then Input 2 have to be used for the Reset Input.

Output test: This is used to select which test output signals are to be sent to the sensor. This additional control permits detection and management of any short-circuits between the lines. To enable this control, the test output signals must be configured (amongst those available).

Test at start-up: If selected this enables the test at start-up of the sensor. This test is performed by occupying and clearing the area protected by the sensor to run a complete function test and enable the output. This test is only requested at machine start-up (when the unit is switched on).

Filter (ms): This is used to filter the signals coming from the sensor. The filter can be configured to between 3 and 250 ms and eliminates any bouncing on the contacts. The length of the filter affects the calculation of the unit's total response time.

Enable Error Out: If selected reports a fault detected by the function block.

Item description: This allows a description of the component's function to be entered. The text is displayed in the top part of the symbol.

S-MAT (safety mat)

The S-MAT function block verifies the status of the inputs of a safety mat. If a person stands on the mat the output is 0 (FALSE). Otherwise, with the mat clear, the output is 1 (TRUE).

Parameters

Manual reset: If selected this enables the request to reset each time the mobile guard/safety gate is activated. Otherwise, enabling of the output directly follows the input conditions.

There are two types of reset: Manual and Monitored. When Manual is selected the system only verifies the signal's transition from 0 to 1. If Monitored is selected the double transition from 0 to 1 and then back to 0 is verified.

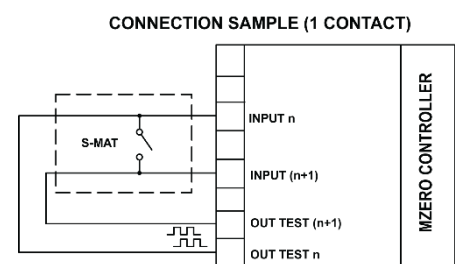
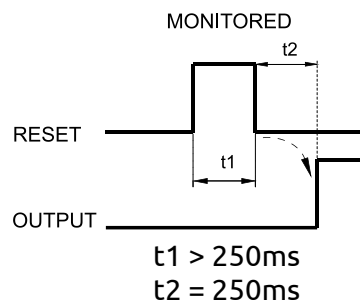
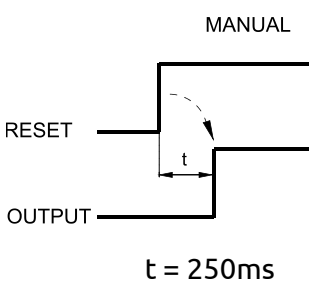
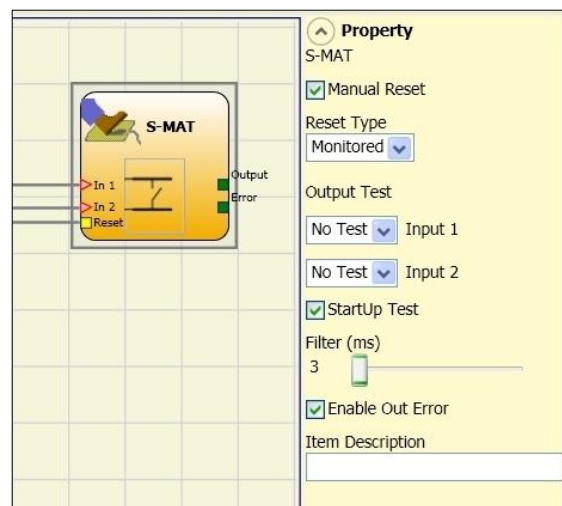

- ➔ If the Manual Reset is active, a consecutive Input have to be used. Example: Input 1 and Input 2 are used for the functional block, then Input 3 have to be used for the Reset Input.
- ➔ Two output test signals are mandatory. Each output OUT TEST can be connected to only one input S-MAT (it is not allowed parallel connection of 2 inputs).
- ➔ The function block S-MAT cannot be used with 2-wire components and termination resistance.

English

Output test: This is used to select which test output signals are to be sent to the s-mat contact. This additional control permits detection and management of any short-circuits between the lines.

To enable this control, the test output signals must be configured (amongst those available). Test signals are mandatory.

Test at start-up: If selected this enables the test at start-up of the external component. This test is performed by pressing and releasing the safety mat to run a complete function test and enable the output. This test is only requested at machine start-up (when the unit is switched on).

Filter (ms): This is used to filter the signals coming from the external contacts. The filter can be configured to between 3 and 250 ms and eliminates any bouncing on the contacts. The length of the filter affects the calculation of the unit's total response time.

Enable Error Out: If selected reports a fault detected by the function block.

Item description: This allows a description of the component's function to be entered. The text is displayed in the top part of the symbol.

SWITCH

SWITCH function block verifies the input status of a pushbutton or switch (NOT SAFETY SWITCHES). If the pushbutton is pressed the output is 1 (TRUE). Otherwise, the output is 0 (FALSE).

Parameters

Manual reset: If selected this enables the request to reset each time the device is activated. Otherwise, enabling of the output directly follows the input conditions.

There are two types of reset: Manual and Monitored. When Manual is selected the system only verifies the signal's transition from 0 to 1.

If Monitored is selected the double transition from 0 to 1 and then back to 0 is verified.

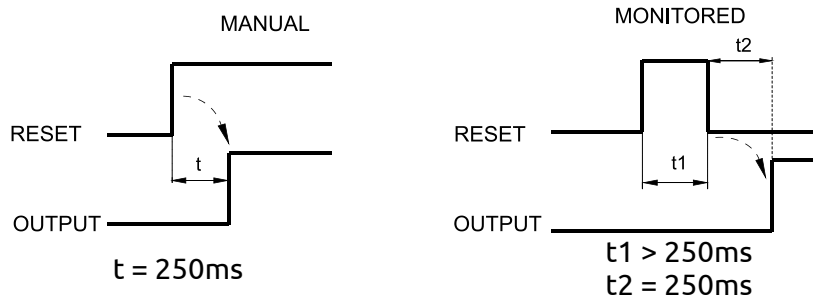
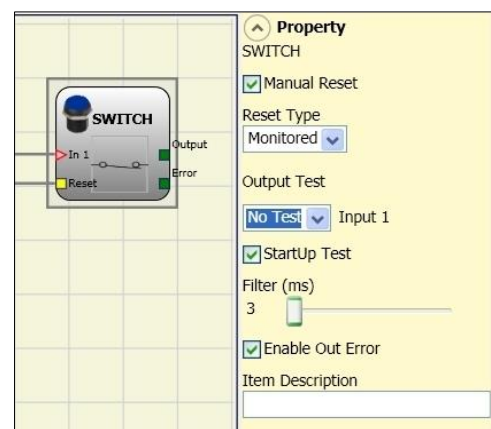

➔ If the Manual Reset is active, a consecutive Input have to be used. Example: Input 1 is used for the functional block, then Input 2 have to be used for the Reset Input.

Output test: This is used to select which test output signals are to be sent to the switch.

This additional control permits detection and management of any short-circuits between the lines. To enable this control, the test output signals must be configured (amongst those available).

Test at start-up: If selected this enables the test at start-up of the switch. This test is performed by opening and closing the switch contact to run a complete function test and enable the output. This test is only requested at machine start-up (when the unit is switched on).

Filter (ms): This is used to filter the signals coming from the switch. The filter can be configured to between 3 and 250ms and eliminates any bouncing on the contacts. The length of the filter affects the calculation of the unit's total response time.

Enable Error Out: If selected reports a fault detected by the function block.

Item description: This allows a description of the component's function to be entered. The text is displayed in the top part of the symbol.

ENABLING GRIP SWITCH

The ENABLING GRIP functional block checks the status of the IN_x inputs of an enabling grip. If this is not gripped (position 1) or is gripped completely (position 3), the OUTPUT will be 0 (FALSE). If it is gripped to middle position (position 2), the OUTPUT will be 1 (TRUE).

Refer to truth tables at the bottom of the page.

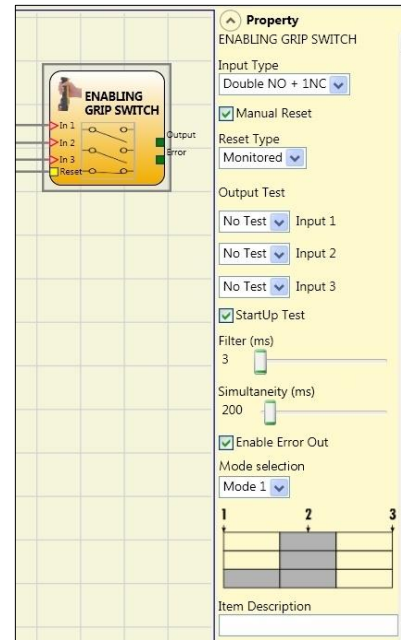

Parameters

Type of inputs:

- with 2 NO contacts.
- Double NO+1NC – Permits connection of an enabling grip switch with 2 NO contacts + 1 NC contact.

Test outputs: Permits selection of the test output signals to be sent to the enabling grip.

This additional control permits detection and management of any short-circuits between the lines. To enable this control, the test output signals must be configured (amongst those available).

Power-on test: If selected, enables the power-on test of the external component (Enabling Grip). To run the test, the device must be gripped and released to carry out a complete functional check and enable the Output terminal. This control is required only at machine start-up (power-on of the module).

Simultaneity (ms): always active. Determines the maximum permissible time (ms) between switching of the various signals from the external contacts of the device.

Filter (ms): Permits filtering of signals from the device control. This filter can be set to between 3 and 250ms and eliminates any rebounds on the contacts. The duration of the filter affects calculation of module total response time.

Table mode 1 (device 2NO + 1NC)

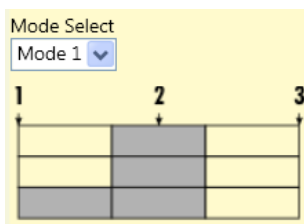

POSITION 1: enabling grip fully released
 POSITION 2: enabling grip pressed to middle position
 POSITION 3: enabling grip fully pressed

	Position		
Input	1	2	3
IN1	0	1	0
IN2	0	1	0
IN3	1	1	0
OUT	0	1	0

Table mode 1 (device 2NO + 1NC)

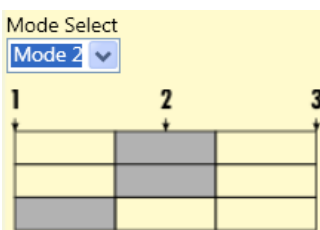

POSITION 1: enabling grip fully released
 POSITION 2: enabling grip pressed to middle position
 POSITION 3: enabling grip fully pressed

	Position	
Input	1	1
IN1	0	1
IN2	0	1
IN3	1	0
OUT	0	1

Enable Error Out: If selected reports a fault detected by the function block.

Item description: Permits insertion of a descriptive text of the function of the component. This text will be displayed in the top part of the symbol.

TESTABLE SAFETY DEVICE

The TESTABLE SAFETY DEVICE functional block checks the status of the Inx inputs of a single or double safety sensor, both NO and NC. Refer to the tables below to check type of sensor and behaviour.

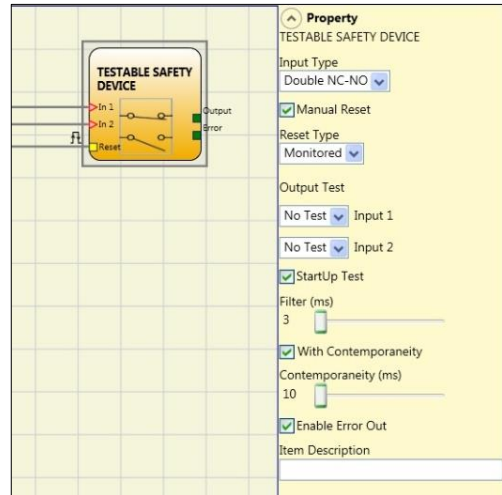

(single NC)



IN1	OUT
0	0
1	1

(single NO)

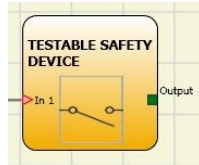

IN1	OUT
0	0
1	1

(double NC)

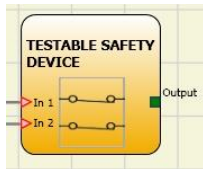

IN1	IN2	OUT	Simultaneity error *
0	0	0	-
0	1	0	X
1	0	0	X
1	1	1	-

(double NC-NO)



IN1	IN2	OUT	Simultaneity error *
0	0	0	X
0	1	0	-
1	0	1	-
1	1	0	X

* Simultaneity error = the maximum time between switching of the single contacts has been exceeded.

Parameters

Manual Reset: If selected, enables the reset request after each activation of the device. Otherwise, enabling of the output follows directly the conditions of the inputs. Reset may be of two types: Manual and Monitored. Selecting the Manual option, only transition of the signal from 0 to 1 is checked. If Monitored is selected, double transition from 0 to 1 and return to 0 is checked.

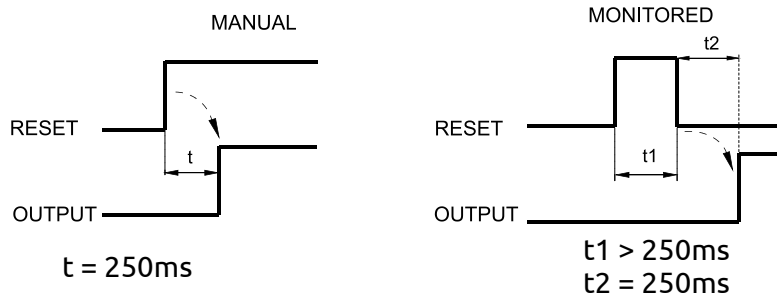

➔ If Reset is enabled, the input consecutive to those used by the functional block must be used. For example: If inputs 1 and 2 are used for the functional block, input 3 must be used for Reset.

Power-on test: If selected, enables the power-on test of the device. This test requires activation and de-activation of the device in order to run a complete functional check and enable the Output terminal. This test is required only at machine start-up (power-on of the module).

Filter (ms): Permits filtering of signals from the device. This filter can be set to between 3 and 250 ms and eliminates any rebounds on the contacts. The duration of the filter affects calculation of module total response time.

With simultaneity: If selected, activates control of simultaneity between switching of signals from the device.

Simultaneity (ms): Is active only if the previous parameter is enabled. Determines the maximum permissible time (ms) between switching of two different signals from the sensor.

Enable Error Out: If selected reports a fault detected by the function block.

Item description: Permits insertion of a descriptive text of the function of the component. This text will be displayed in the top part of the symbol.

SOLID STATE DEVICE

The SOLID STATE DEVICE functional block checks the status of the Inx inputs. If the inputs are at 24VDC, the Output will be 1 (TRUE), otherwise the OUTPUT will be 0 (FALSE).

Parameters

Manual Reset: If selected, enables the reset request after each safety function activation. Otherwise, enabling of the output follows directly the conditions of the inputs. Reset may be of two types: Manual and Monitored. Selecting the Manual option, only transition of the signal from 0 to 1 is checked. If Monitored is selected, double transition from 0 to 1 and return to 0 is checked.

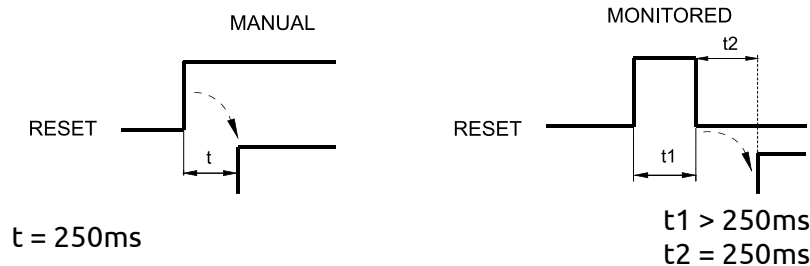
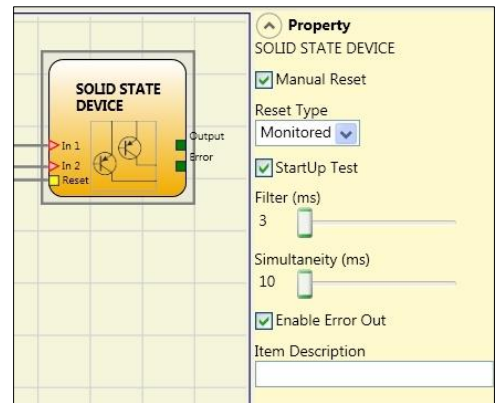

⚠ If Reset is enabled, the input consecutive to those used by the functional block must be used. For example: if inputs 1 and 2 are used for the functional block, input 3 must be used for Reset.

Power-on test: If selected, enables the power-on test of the safety device. This test requires activation and de-activation of the device in order to run a complete functional check and enable the Output terminal. This test is required only at machine start-up (power-on of the module).

Filter (ms): Permits filtering of signals from the safety device. This filter can be set to between 3 and 250 ms and eliminates any rebounds on the contacts. The duration of the filter affects calculation of module total response time.

Simultaneity (ms): always active. Determines the maximum permissible time (ms) between switching of the various signals from the external contacts of the device.

Enable Error Out: If selected reports a fault detected by the function block.

Item description: Permits insertion of a descriptive text of the function of the component. This text will be displayed in the top part of the symbol.

RESTART INPUT

The element can be used as a digital input (in addition to the 16 available on MZERO) and connected to any external device.

The usable inputs are referred to RESTART_FBK signals of MZERO (TERMINALS 7, 11, 15, 19).

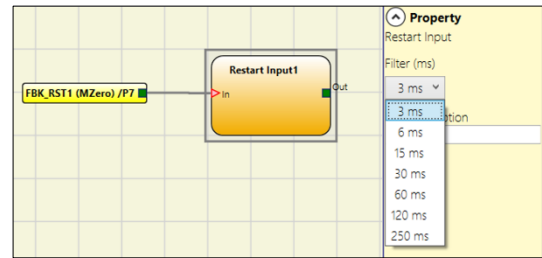

Parameters

Filter (ms): Permits filtering of signals from the external device. This filter can be set to between 3 and 250 ms and eliminates any rebounds on the contacts. The duration of the filter affects calculation of module total response time.

LL0-LL1

These items allow a predefined logical level to be entered on a component's input.

LL0 -> logical level 0

LL1 -> logical level 1



LL0 and LL1 cannot be used to disable the logical ports in the diagram.

COMMENTS

This item allows a description to be entered and placed in any point of the diagram.

Parameters

Comment: If selected, it can be filled with the desired comment.

Color: select the color of the comment text.

Height: select the dimension of the comment text.

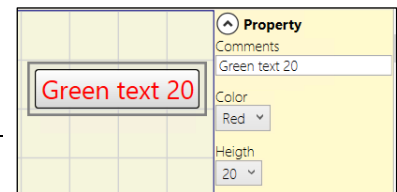

TITLE

Automatically adds the name of the manufacturer, the designer, the project name and the CRC.

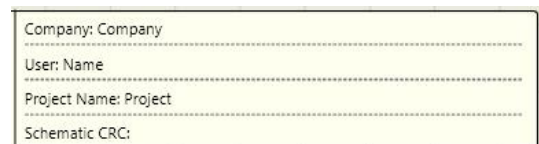

OPERATOR FUNCTION BLOCKS

All the input of these operators could be inverted (logical NOT). It could be done clicking with the right mouse key on the input to be inverted. A little circle will be showed on the inverted input. To cancel the inversion, simply click another time on the same input pin.

→ The maximum number of functional blocks is 64.

LOGICAL OPERATORS

AND

Logical AND returns an output of 1 (TRUE) if all the inputs are 1 (TRUE).

In ₁	In ₂	In _x	Out
0	0	0	0
1	0	0	0
0	1	0	0
1	1	0	0
0	0	1	0
1	0	1	0
0	1	1	0
1	1	1	1



Parameters

Number of inputs: this is used to set between 2 and 8 inputs.

NAND

Logical NAND returns an output of 0 (FALSE) if all the inputs are 1 (TRUE).

In ₁	In ₂	In _x	Out
0	0	0	1
1	0	0	1
0	1	0	1
1	1	0	1
0	0	1	1
1	0	1	1
0	1	1	1
1	1	1	0



Parameters

Number of inputs: this is used to set between 2 and 8 inputs.

NOT

Logical NOT inverts the logical status of the input.

In	Out
0	1
1	0

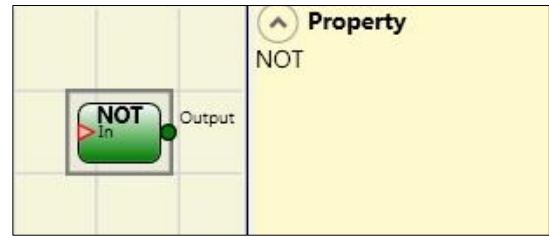

OR

Logical OR returns an output of 1 (TRUE) if at least one of the inputs is 1 (TRUE).

In ₁	In ₂	In _x	Out
0	0	0	0
1	0	0	1
0	1	0	1
1	1	0	1
0	0	1	1
1	0	1	1
0	1	1	1
1	1	1	1

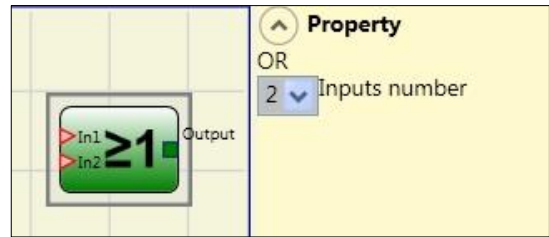

Parameters

Number of inputs: this is used to set between 2 and 8 inputs.

NOR

Logical NOR returns an output of 0 (FALSE) if at least one of the inputs is 1 (TRUE).

In ₁	In ₂	In _x	Out
0	0	0	1
1	0	0	0
0	1	0	0
1	1	0	0
0	0	1	0
1	0	1	0
0	1	1	0
1	1	1	0

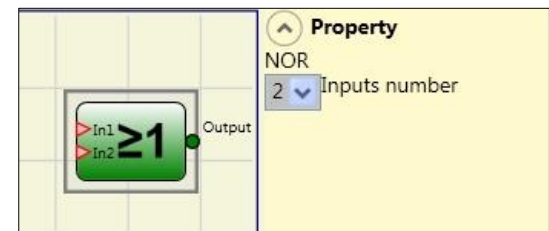

Parameters

Number of inputs: this is used to set between 2 and 8 inputs.

XOR

Logical XOR returns an output 0 (FALSE) if the input's number at 1 (TRUE) is even or the inputs are all 0 (FALSE).

In1	In2	Inx	Out
0	0	0	0
1	0	0	1
0	1	0	1
1	1	0	0
0	0	1	1
1	0	1	0
0	1	1	0
1	1	1	1



Parameters

Number of inputs: this is used to set between 2 and 8 inputs.

XNOR

Logical XNOR returns an output 1 (TRUE) if the input's number at 1 (TRUE) is even or the inputs are all 0 (FALSE).

In1	In2	Inx	Out
0	0	0	1
1	0	0	0
0	1	0	0
1	1	0	1
0	0	1	0
1	0	1	1
0	1	1	1
1	1	1	0

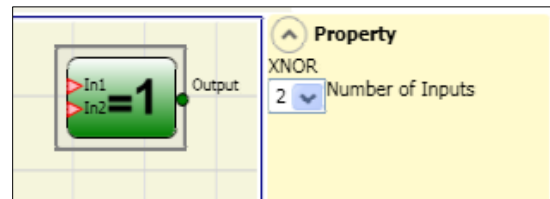

Parameters

Number of inputs: this is used to set between 2 and 8 inputs.

LOGICAL MACRO

This operator enables the grouping together of two or three logic gates.

A maximum of 8 inputs is foreseen.

The result of the first two operators converges into a third operator, the result of which is the OUTPUT.

Parameters

Logic inputs 1, 2: enables the selection of the number of logic inputs (from 1 to 7).

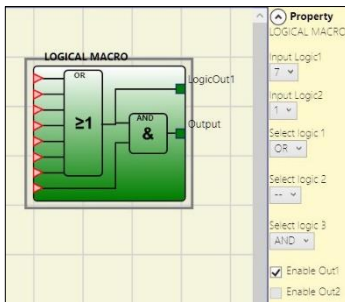

If one of the Logic Inputs equals "1", the corresponding logic is disabled and the input is directly connected to the end logic (e.g. see diagram on the left).

Select Logic 1, 2, 3: enables the selection of one of the following types of operator: AND, NAND, OR, NOR, XOR, XNOR, SR Flip-Flop (the latter only for logic 3).

Disable OUT: If selected, it deactivates the main output allowing to use only logics 1 and/or 2 enabling their respective outputs

Enable (OUT1, OUT2): If selected, it activates an output with the result of logics 1 and/or 2.

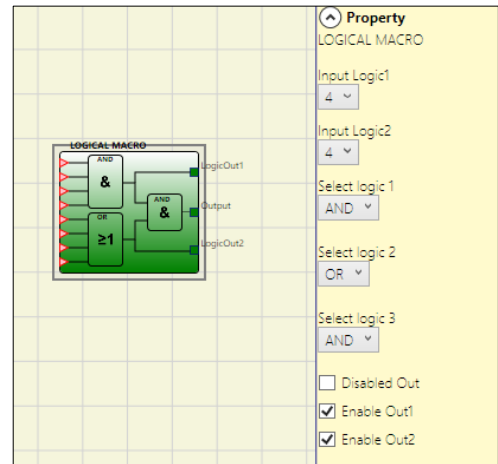

MULTIPLEXER

Logical MULTIPLEXER forwards the signal of the inputs to the output according to the Sel selection. If the SEL1...SEL4 have only one bit set, the selected *In n* is connected to the Output. As an example if "Sel2" is set to 1 then the "In 2" is forwarded to the "Output" the SEL inputs are:

- more than one = 1 (TRUE)
- none = 1 (TRUE)

the output is set to 0 (FALSE) independently from the *In n* values.

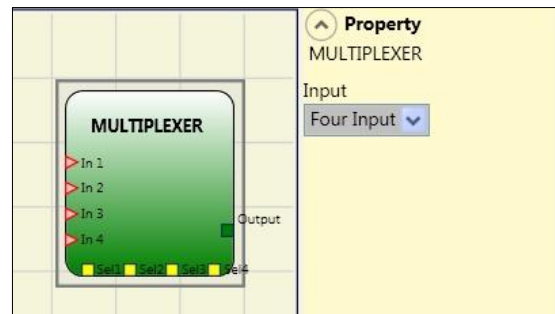

Parameters

Number of inputs: this is used to set between 2 and 4 inputs.

DIGITAL COMPARATOR

The digital comparator allows to compare (in binary format) a group of signals with a constant or two groups of signals to each other

Comparison with constant

In this case the Signal Comparator check must not be activated.

The DIGITAL COMPARATOR block allows to compare a series of input signals (from 2 to a maximum of 8). The integer constant could be inputted directly as Decimal number or as a combination of binary values. In the latter In1 is the LSB (least significant bit) while input In8 (or less if the number of inputs selected is less than 8) is the MSB (most significant bit).

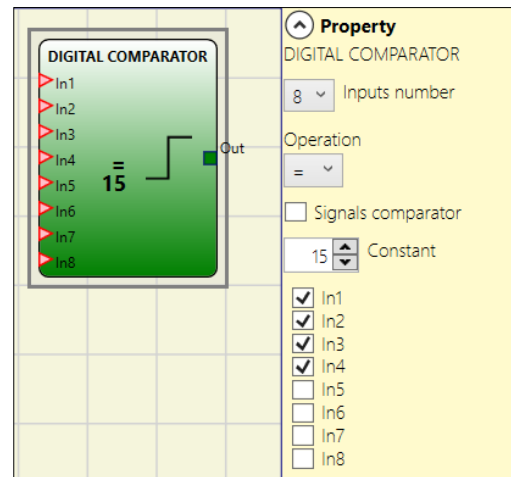

Example of operator with 8 inputs:

In1 → 0
 In2 → 1
 In3 → 1
 In4 → 0
 In5 → 1
 In6 → 0
 In7 → 0
 In8 → 1

Decimal value equal to 150.

Example of operator with 5 inputs:

In1 → 0
 In2 → 1
 In3 → 0
 In4 → 1
 In5 → 1

Decimal value equal to 26.

The user could choice among various operation listed below:

- **< (Lower)** The OUT output will be 1 (TRUE) as long as the input value is less than the decimal value set as constant. The OUT output will be set to 0 (FALSE) when the input value is higher than or equal to the decimal value set as constant.
- **>= (Higher) or equal** The OUT output will be 1 (TRUE) as long as the input value is higher than or equal to the decimal value set as constant. The OUT output will be set to 0 (FALSE) when the input value is lower than the decimal value set as constant.
- **> (Higher)** The OUT output will be 1 (TRUE) as long as the input value is higher than the decimal value set as constant. The OUT output will be set to 0 (FALSE) when the input value is lower than or equal to the decimal value set as constant.
- **<= (Lower or equal)** The OUT output will be 1 (TRUE) as long as the input value is lower than or equal to the decimal value set as constant. The OUT output will be set to 0 (FALSE) when the input value is higher than the decimal value set as constant.
- **= (Equal)** The OUT output will be 1 (TRUE) as long as the input value is equal to the decimal value set as constant. The OUT output will be set to 0 (FALSE) when the input value is different from the decimal value set as constant.
- **!= (Different)** The OUT output will be 1 (TRUE) as long as the input value is different from the decimal value set as constant. The OUT output will be set to 0 (FALSE) when the input value is equal to the decimal value set as constant.

Signal comparison

Signal comparison: Selecting this item will allow the DIGITAL COMPARATOR operator to compare the first four A inputs (In1_A...In4_A) with the second four B inputs (In1_B...In4_B). Depending on the value of the inputs and the operation selected, the following results will be obtained:

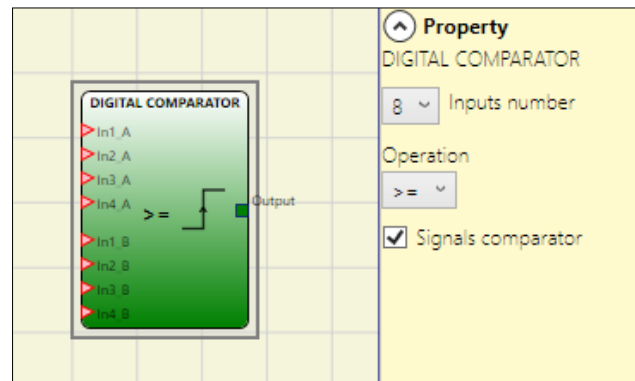

- < (Lower): The OUT output will be 1 (TRUE) as long as the value of A inputs is lower than the value of B inputs. The OUT output will be set to 0 (FALSE) when the value of A inputs is higher than or equal to the value of B inputs.
- >= (Higher or equal): The OUT output will be 1 (TRUE) as long as the value of A inputs is higher than or equal to the value of B inputs. The OUT output will be set to 0 (FALSE) when the value of A inputs is lower than the value of B inputs.
- > (Higher): The OUT output will be 1 (TRUE) as long as the value of A inputs is higher than the value of B inputs. The OUT output will be set to 0 (FALSE) when the value of A inputs is lower than or equal to the value of B inputs.
- <= (Lower or equal): The OUT output will be 1 (TRUE) as long as the value of A inputs is lower than or equal to the value of B inputs. The OUT output will be set to 0 (FALSE) when the value of A inputs is higher than the value of B inputs.
- = (Equal): The OUT output will be 1 (TRUE) as long as the value of A inputs is equal to the value of B inputs. The OUT output will be set to 0 (FALSE) when the value of A inputs is different from the value of B inputs.
- != (Different): The OUT output will be 1 (TRUE) as long as the value of A inputs is different from the value of B inputs. The OUT output will be set to 0 (FALSE) when the value of A inputs is equal to the value of B inputs.

MEMORY OPERATORS

MEMORY operators can be used if you decide to save any data (TRUE or FALSE) from other project components.

Status changes are performed according to the truth tables shown for each operator.

D FLIP FLOP (max number = 16)

The D FLIP FLOP operator saves the previously set status on output Q according to the following truth table.

Preset	Clear	Ck	D	Q
1	0	X	X	1
0	1	X	X	0
1	1	X	X	0
0	0	L	X	Keep memory
0	0	Rising edge	1	1
0	0	Rising edge	0	0

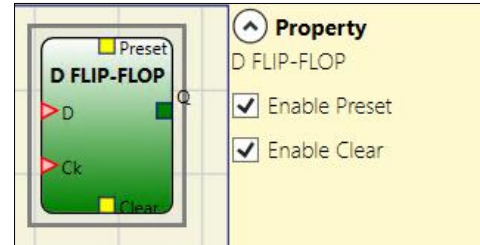

Parameters

Preset: If selected enables output Q to be set to 1 (TRUE).

Clear: If selected enables the saving process to be reset.

T FLIP FLOP (max number = 16)

This operator switches the Q output at each rising edge of the T input (Toggle).

Parameters

Enable Clear: If selected enables the saving process to be reset.

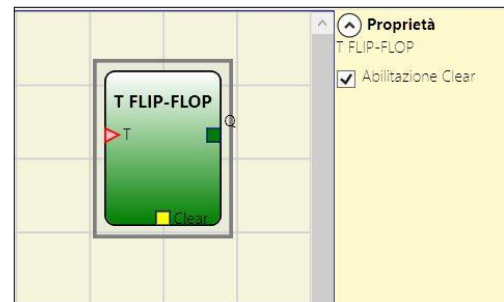

SR FLIP FLOP

SR FLIP FLOP operator brings output Q at 1 with Set, 0 with Reset.

See the following truth table.

SET	RESET	Q
0	0	Keep memory
0	1	0
1	0	1
1	1	0

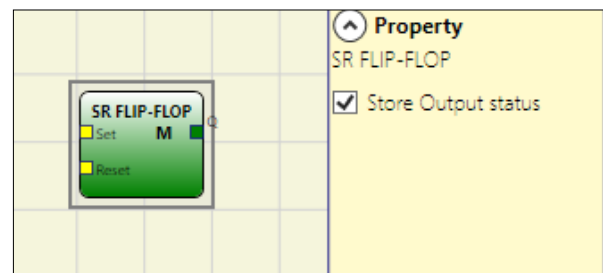

Parameters

Store output status: If selected, it stores the output status of the Flip-flop in non-volatile memory every time it is changed. When the system is turned on, the last stored value is restored. It is possible to have up to 8 Flip-Flops with output status storage that will be distinguishable by an 'M'.

- ➔ Some limitations to the use of this storage. The maximum time required for a single storage is estimated at 50ms and the maximum number of possible storages is set at 100000.
- ➔ The total number of storages must not exceed the set limit, otherwise the operational life of the product will be reduced, and the frequency of such storages must be sufficiently low to enable them to be stored safely.

Mandatory: do not use this storage for safety-related purposes.

USER RESTART MANUAL
(max number = 16)

The USER RESTART MANUAL operator saves the restart signal (coming from a RESTART command device) according to the following truth table.

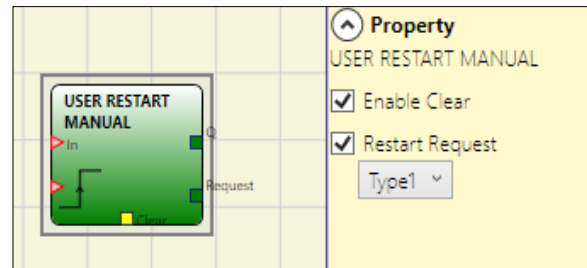

Clear	Restart	In	Q	Restart Request Type 1	Restart Request Type 2*
1	X	X	0	0	1
X	X	0	0	0	1
0	0	1	Keep Memory	1	Blinking 1Hz
0	Rising Edge	1	1	0	0

Parameters

Clear enable: If selected, enables an input to reset the memorization.



Restart request: If selected, it enables an output that can be used to signal the possibility of performing the Restart. The behaviour can be of **type 1** or **type 2** as represented in the truth table.

* Restart Request Type 2 uses a system timer

USER RESTART MONITORED (max number = 16)

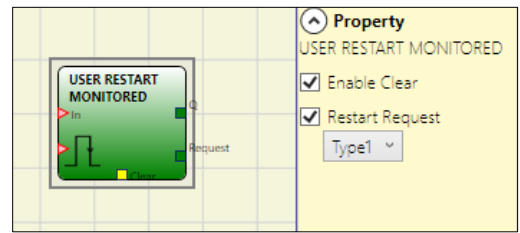
The USER RESTART MONITORED operator is used to save the restart signal (coming from a RESTART command device) according to the following truth table.



Clear	Restart 	In	Q	Restart Request Type 1	Restart Request Type 2*
1	X	X	0	0	1
X	X	0	0	0	1
0	0	1	Keep Memory	1	Blinking 1Hz
0		1	1	0	0

Parameters

Clear enable: If selected, enables an input to reset the memorization.



Restart request: If selected, it enables an output that can be used to signal the possibility of performing the Restart. The behaviour can be of **type 1** or **type 2** as represented in the truth table.

*This output uses a system timer

MACRO RESTART MANUAL (max number = 16)

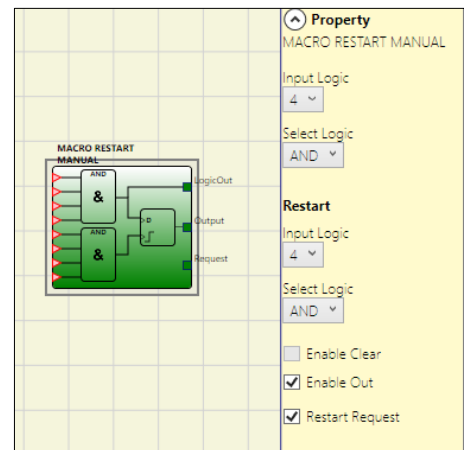
The MACRO RESTART MANUAL operator is used to combine a logic gate chosen by the user with the Restart Manual functional block ("USER RESTART MANUAL") in accordance with the following truth table.



Clear	Restart Logic Out 	Input Logic Out	Output	Restart Request
1	X	X	0	0
X	X	0	0	0
0	0	1	Keep memory	1
0	Rising Edge 	1	1	0

Parameters

Input Logic: enables the selection of the number of logic inputs (from 1 to 7). Selecting 1 the logic will not be considered.

Select Logic: enables the selection of one of the following types of operator: AND, NAND, OR, NOR, XOR, XNOR.

Restart Input Logic: enables the selection of the number of inputs for restart logic (from 1 to 7). If you select 1 the logic will not be considered.

Restart Select Logic: enables the selection of one of the following types of operator for restart logic: AND, NAND, OR, NOR, XOR, XNOR.

Enable Clear: If selected, enables an input to reset the memorization.

Enable Out: If selected activates an output with the result of the calculation done by the input logic.

Restart request: If selected, it enables an output that can be used to signal the possibility of performing the Restart. The behaviour is represented in the truth table.

MACRO RESTART MONITORED (max number = 16)

The MACRO RESTART MONITORED operator is used to combine a logic gate chosen by the user with the Restart Manual functional block ("USER RESTART MONITORED") in accordance with the following truth table.

Clear	Restart Logic Out	Input Logic Out	Output	Restart Request
1	X	X	0	0
X	X	0	0	0
0	0	1	Keep memory	1
0		1	1	0

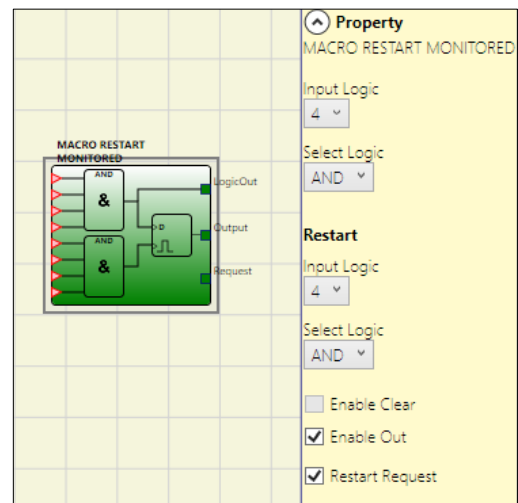

Parameters

Input Logic: enables the selection of the number of logic inputs (from 1 to 7). Selecting 1 the logic will not be considered.

Select Logic: enables the selection of one of the following types of operator: AND, NAND, OR, NOR, XOR, XNOR.

Restart Input Logic: enables the selection of the number of inputs for restart logic (from 1 to 7). If you select 1 the logic will not be considered.

Restart Select Logic: enables the selection of one of the following types of operator for restart logic: AND, NAND, OR, NOR, XOR, XNOR.

Enable Clear: If selected, enables an input to reset the memorization.

Enable Out: If selected activates an output with the result of the calculation done by the input logic.

Restart request: If selected, it enables an output that can be used to signal the possibility of performing the Restart. The behaviour is represented in the truth table.

PRE-RESET (max number = 32 with other RESTART operators)

The PRE-RESET operator can be used when there is no possibility of having a single reset button in a position from which a complete visibility of the hazardous area is available.

In this case it is necessary to use a PRE-RESET button inside a zone of operation with a complete visibility and a RESET button outside the zone of operation to activate the Q output.

For both Pre-reset and Reset inputs the transition 0->1->0 is considered a valid signal. It is mandatory that the pulse 0->1->0 has a maximum duration of 5s.

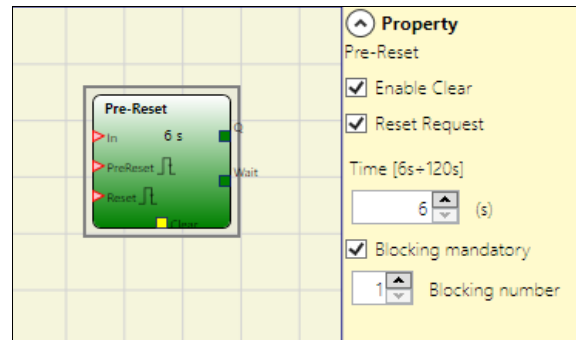

Parameters

Time: The external reset is operative if pressed within a preset time configurable by the user in the range 6...120s

Blocking Mandatory: If selected, the minimum number of interruptions (of the light curtain or similar) is 1 before the RESET signal can be activated.

If you specify a BLOCKING NUMBER other than 1, this number corresponds to the maximum permissible number of interruptions.

Blocking number: Blocking number has the range from 1 to 7.

Reset Request: Enabling this item will make available an output from this operator. This signal is 1 from the PreReset signal transition to the end of the allowable time or to the next Reset signal transition.

Enable Clear: If selected, enables an input to reset the memorization.

The behavior of the PRE-RESET operator is shown in the following timings:

WITHOUT BLOCKING MANDATORY

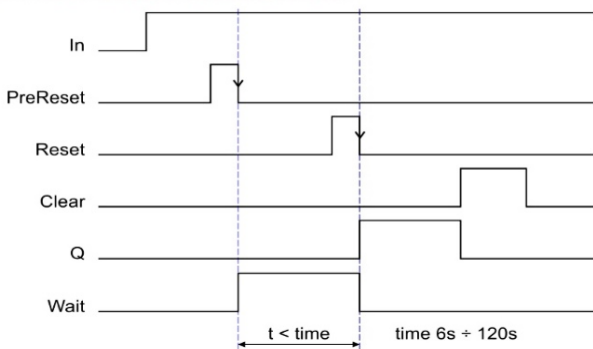

WITH BLOCKING MANDATORY (Blocking number = 2)

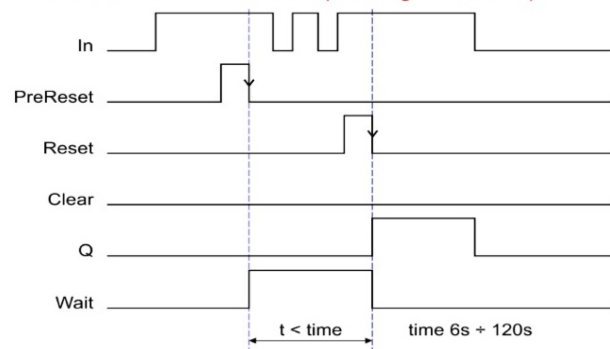

GUARD LOCK OPERATORS (max number = 4)

GUARD LOCK

The “**GUARD LOCK**” operator is designed to control locking/unlocking of an **ELECTROMECHANICAL GUARD LOCK** in a variety of operating contexts.

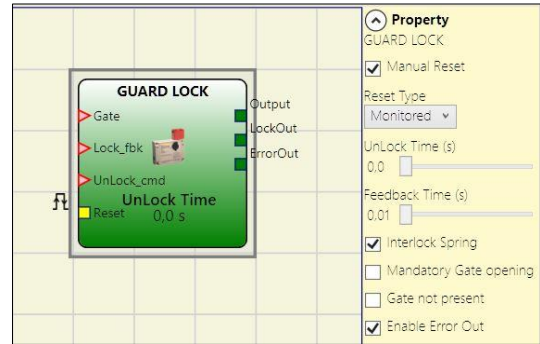

Parameters

Manual Reset:

There are two types of reset: Manual and Monitored. When Manual is selected the system only verifies the signal's transition from 0 to 1. If Monitored is selected the double transition from 0 to 1 and then back to 0 is verified.

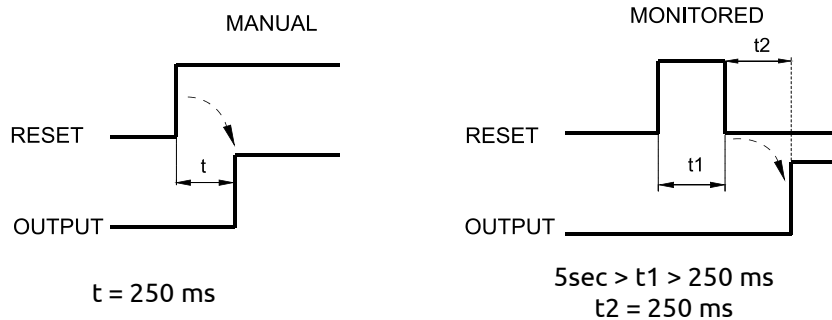

Unlock Time (s):

The time that must pass between the **UnLock_cmd** input reaching and the real guard unlock (**Lockout output**).

- 0ms...1 s Step 100 ms
- 1.5 s...10 s Step 0.5 s
- 15 s...25 s Step 5 s

Feedback Time (s):

Maximum delay accepted between **LockOut** output and **Lock_fbk** input (must be the one shown on the lock data sheet with appropriate gap decided by the operator).

- 10ms...100 s Step 10 ms
- 150ms...1 s Step 50 ms
- 1.5 s...3 s Step 0.5 s

Interlock Spring: The guard is locked passively and released actively, i.e. the mechanical force of the spring keeps it locked. *The guard thus continues to be locked even when the power supply is disconnected.*

Mandatory gate opening: Only with door opening and subsequent confirmation of input GATE, the cycle proceeds.

Gate not present: If selected, enables configuration without Gate but only with LOCK FEEDBACK (feedback coil lock).

Enable error out: This can be selected to enable a signal (Error Out) to indicate a lock malfunction. When Error Out = 1 (TRUE) there is a fault in the lock. (e.g. open door with guard lock locked, Feedback Time exceeding the maximum allowed, etc.).

Description of "GUARD LOCK" operator inputs/outputs

"Lock_fbk" input

The "Lock_fbk" input is used to detect the status (feedback) of the electromagnet that unlocks/locks the guard lock.

Electromechanical guard locks are unlocked/locked via an electric control that energises/de-energises an electromagnet. Its status (energised/de-energised) is indicated by appropriate contacts. For example, the status of the electromagnet may be indicated by a normally open contact that is closed when the electromagnet is energised, as in the case shown in Figure 31.

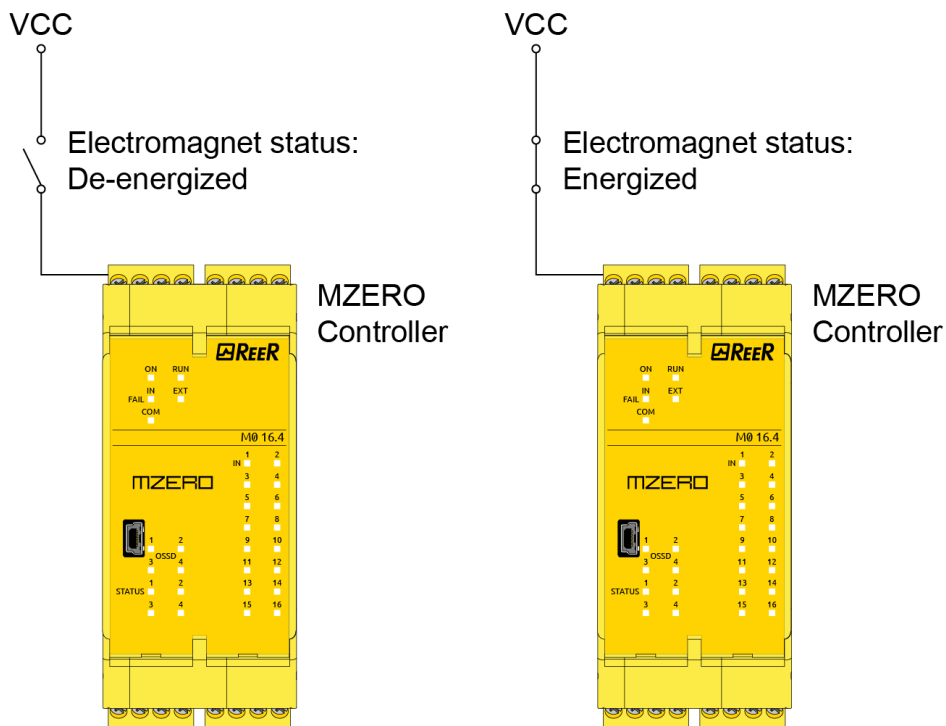

Figure 31 - Example of feedback of the status of the electromagnet of a guard lock. The signal received by the module is processed by the "Guard Lock" operator.

"Gate" input

When the "Gate" input is present, it detects the status (feedback) of the door/gate connected to the guard lock.

The status of the door/gate (GATE) is detected using specific contacts. For example, the status of the door/gate may be indicated by a normally open contact that is closed when the door/gate is closed, as in the case in Figure 32.

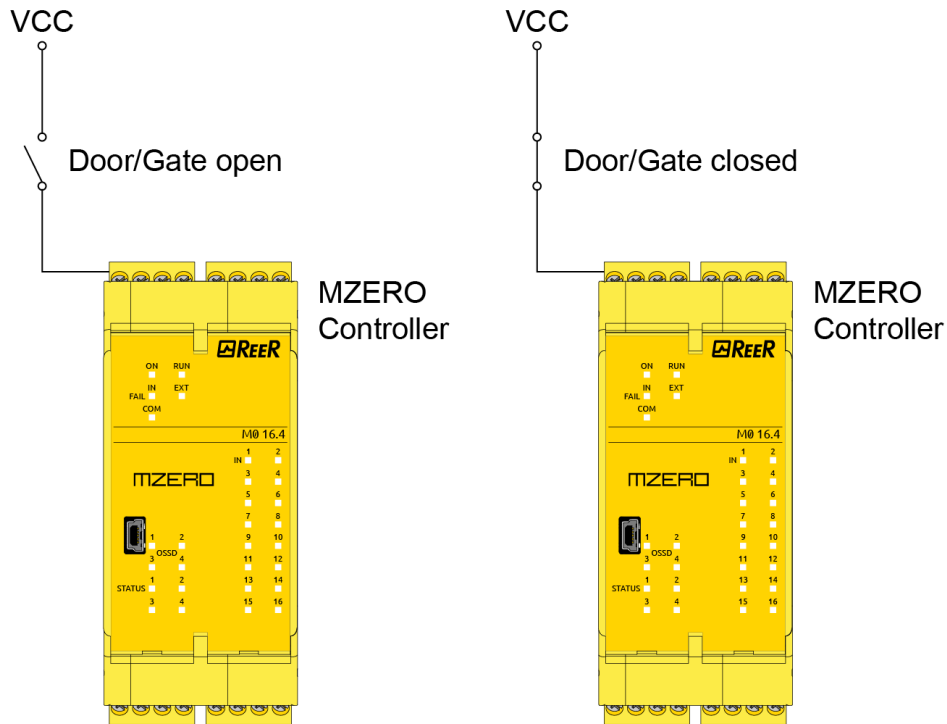

Figure 32 - Example of feedback of the status of a door/gate connected to the guard lock. The signal received by the module is processed by the "Guard Lock" operator.

"Unlock_cmd" input

The "Unlock_cmd" input detects the command sent by the user to lock or unlock the guard lock. In detail:

- Request to unlock: the Unlock_cmd signal must be set to LL1
- Request to lock: the Unlock_cmd signal must be set to LL0

The command signal may be sent via a key, for example.

"Output" out

This signal indicates the information shown in the table below, depending on its value.

	Value	Meaning
Output	LL1	<ul style="list-style-type: none"> • Door/Gate closed • Guard lock locked
Output	LL0	<ul style="list-style-type: none"> • User request to unlock the guard lock • Error condition

“LockOut” output

This signal controls the guard lock electromagnet and can assume LL0 and LL1 value.

“ErrorOut” output

If enabled, when this signal is set to LL1 it indicates an error in the control of the guard lock. It is set to LL0 when no errors have occurred.

Operation: general description

The “Guard Lock” operator analyses consistency between the status of the “Unlock_cmd” signal, the status of a door/gate (E-GATE), if present, via the “Gate” signal, and the status of the electromagnet via the “Lock_fbk” signal. The main output, “Output”, is LL1 (TRUE) when the guard lock is closed and locked.

Operation in the “no Gate” mode

In this case, the user must select the “Gate not present” parameter.

The **Lock_Fbk** input must always be connected to a “LOCK FEEDBACK” input element (see the LOCK FEEDBACK section on page 46) that verifies the status of the guard lock electromagnet.

The **UnLock_cmd** input can be connected freely in the diagram and determines the request to unlock the guard lock (when set to LL1).

The **Output** signal is LL1 (TRUE) if the safety guard is locked. When an unlock command is applied to the **UnLock_cmd** input, the **Output** signal is set to LL0 and the guard lock is unlocked via the **LockOut** signal.

The **Output** signal can also be set to LL0 (FALSE) when error conditions are present. (e.g. *Feedback Time* exceeding the maximum allowed, etc.).

When the **UnLock_cmd** signal is detected, the **LockOut** signal unlocks the guard lock after the *UnLock Time*, a parameter that can be defined by the user.

The time after which the electromagnet is activated depends entirely on the technical/physical characteristics of the specific device and may therefore vary according to the type of guard lock used. Thus, since the **LockOut** signal controls the activation of this device, the status of the **Lock_Fbk** feedback signal will change at different times, depending on the type of guard lock. This variability can be avoided by changing the value of the *Feedback Time* parameter, which is the maximum delay accepted by the “Guard_Lock” operator before the **Lock_Fbk** signal switches status following a request to activate the electromagnet. Clearly, the following condition must be met:

$$Feedback\ Time \geq Electromagnet\ activation\ time$$

This will now be explained using a practical example.



Example of operation in the "no Gate" mode

The guard lock used in the example continues to be locked when the electromagnet is not energised. Hence the "Interlock spring" option must be selected.

The user unlocks the guard lock with the "SWITCH" block. The "LockOut" signal controls a "STATUS" SIL 1/PL c output block that controls the guard lock electromagnet, the status of which is detected by the "Lock_fbK" input via the "LOCK FEEDBACK" input block. "Output1" indicates the status of the operations.

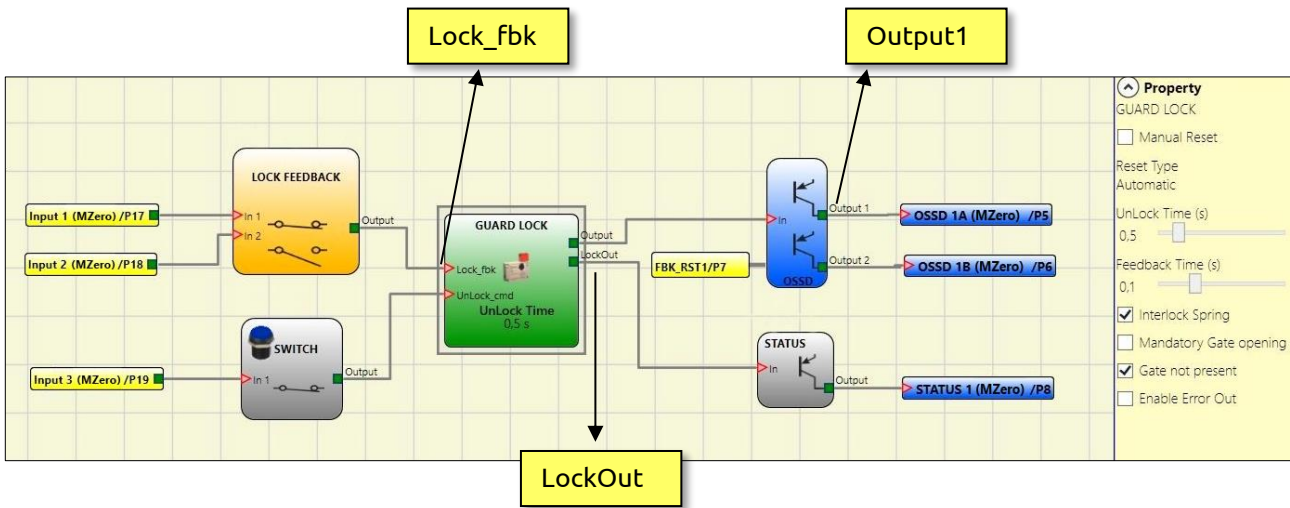

Figure 33 – Example of operation in the no Gate mode

➔ The Guard Lock operator parameters are shown on the right. On the left there is an example of an application diagram. The electromagnet feedback consists of two contacts, one normally closed and one normally open. When the electromagnet is energised the two contacts switch status.

Figure 34 shows the traces relative to the operation. These are described in detail below:

- (1) At this time the user requests to unlock the guard lock. The "COMMAND" signal switches from LL0 to LL1, and the "OUTPUT1" signal switches from LL1 to LL0.
- (2) At this time the electromagnet is activated with a delay of "Unlock Time", after the command is sent. This delay has been set to 0.5 seconds. The "ACTIV." signal switches from LL0 to LL1.
- (3) At this time the electromagnet is actually activated, 95ms after the command was sent. This delay is due to the technical characteristics of the electromagnet. In any case, 95ms is less than 100ms ("Feedback Time") and so no errors have occurred.
- (4) At this time the user releases the unlock command and the "COMMAND" signal switches from LL1 to LL0 as does the "ACTIV." activation signal.
- (5) At this time the electromagnet is actually deactivated, approx. 95ms after the command was sent due to the technical characteristics of the device. The guard lock is now locked.
- (6) As soon as the "Guard Lock" operator detects that the guard lock is locked, the "OUTPUT1" signal switches to LL1.

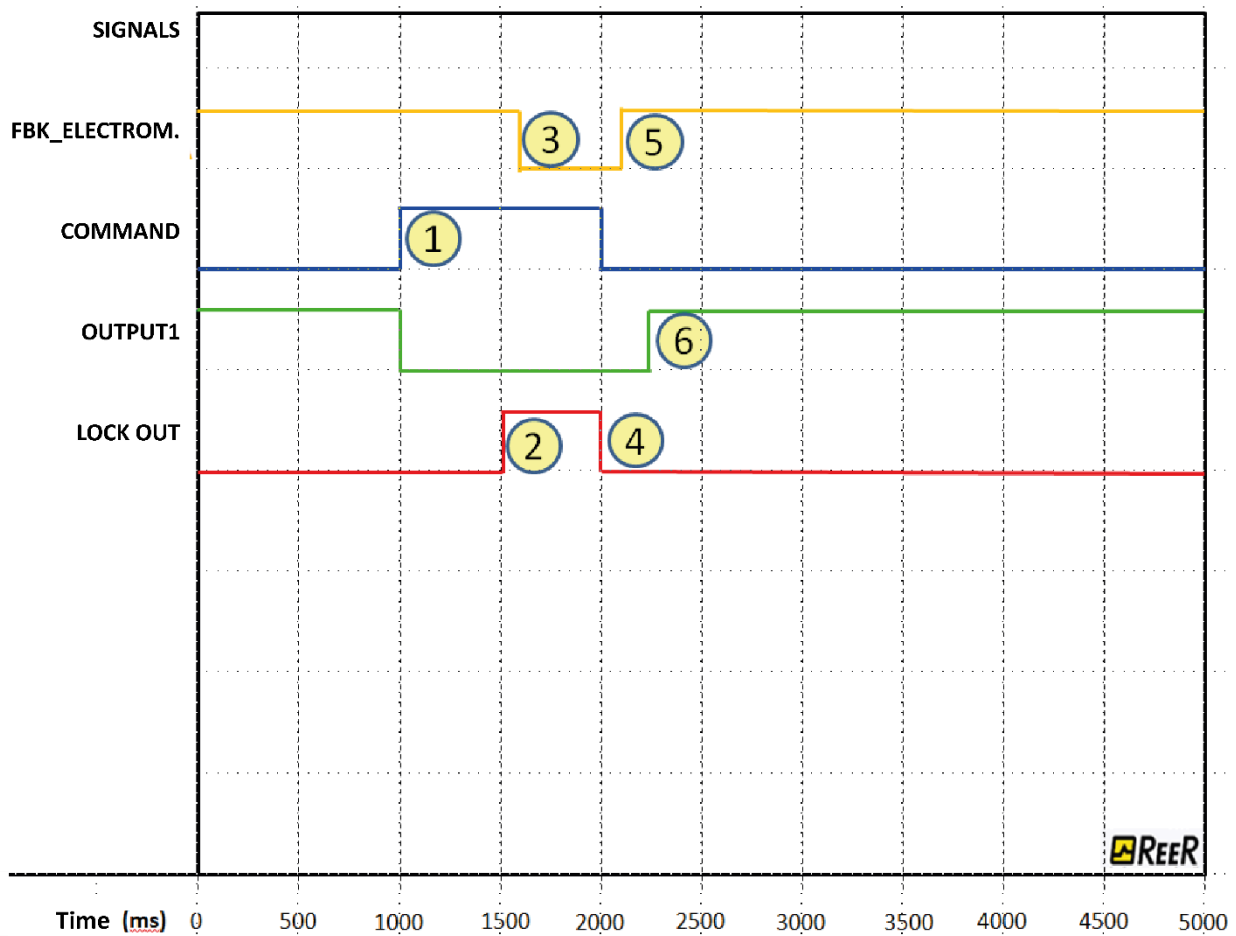

Figure 34 - Traces relative to "Guard Lock" block operation in the no gate mode.

Operation in the "with Gate" mode

In this case, the user must **NOT** select the "Gate not present" parameter.

The **Gate** input must always be connected to an "E-GATE" input element (see the E-GATE (safety gate device) section on page 44) that verifies the status of the door/gate.

The **Lock_Fbk** input must always be connected to a "LOCK FEEDBACK" input element (see the LOCK FEEDBACK section on page 46) that verifies the status of the guard lock electromagnet.

The **UnLock_cmd** input can be connected freely in the diagram and determines the request to unlock the guard lock (when set to LL1).



The **Output** signal is LL1 (TRUE) if the safety guard is closed and locked. When an unlock command is applied to the **UnLock_cmd** input, the **Output** signal is set to LL0 and the guard lock is unlocked via the **LockOut** signal. The **Output** signal can also be set to LL0 (FALSE) when error conditions are present (e.g. open door with guard lock locked, **Feedback Time** exceeding the maximum allowed, etc.).

When the **UnLock_cmd** signal is detected, the **LockOut** signal unlocks the guard lock after the **UnLock Time**, a parameter that can be defined by the user.

The time after which the electromagnet is activated depends entirely on the technical/physical characteristics of the specific device and may therefore vary according to the type of guard lock used. Thus, since the **LockOut** signal controls the activation of this device, the status of the **Lock_Fbk** feedback signal will change at different times, depending on the type of guard lock. This variability can be avoided by changing the value of the *Feedback Time* parameter, which is the maximum delay accepted by the "Guard_Lock" operator before the **Lock_Fbk** signal switches status following a request to activate the electromagnet. Clearly, the following condition must be met:

$$\text{Feedback Time} \geq \text{Electromagnet activation time}$$

This will now be explained using a practical example.

Example of operation in the "with Gate" mode

In this example the user unlocks the guard lock with the "SWITCH" block. The "LockOut" signal controls an "STATUS" SIL 1/PL c output that controls the guard lock electromagnet, the status of which is detected by the "Lock_fbk" input via the "LOCK FEEDBACK" input block. "Output1" indicates the status of the operations.

The status of the safety gate is monitored by the "Gate" input via the "E_GATE" input. The guard lock used in the example continues to be locked when the electromagnet is not energised. Hence the "Interlock spring" option must be selected.

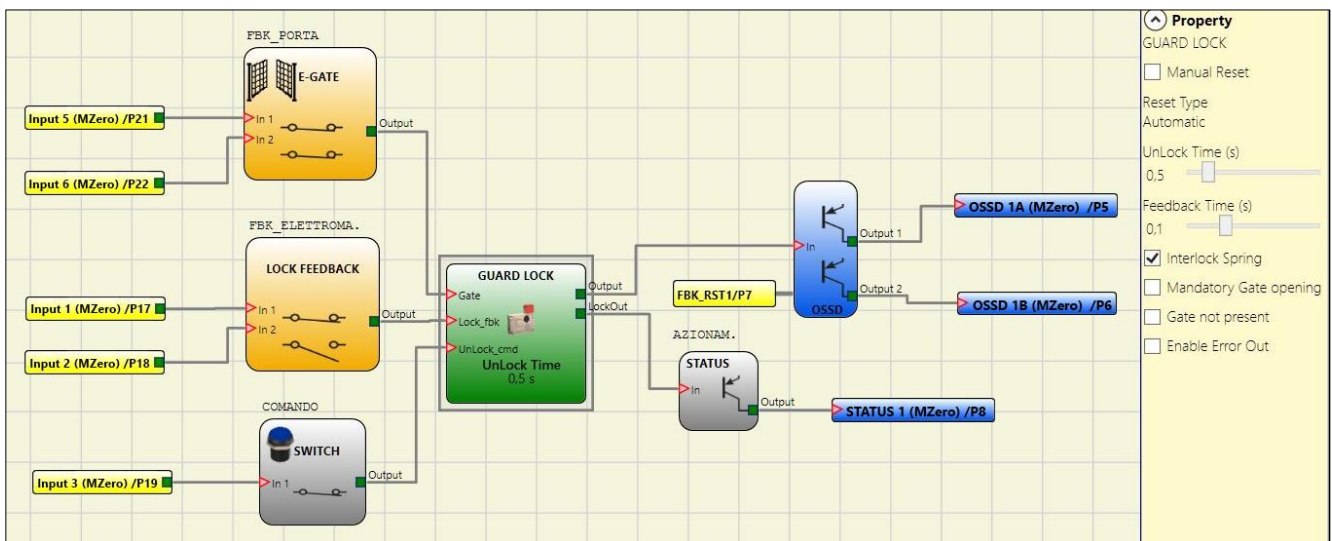

Figure 35 – Example of operation in the with Gate mode

➔ The Guard Lock operator parameters are shown on the right. On the left there is an example of an application diagram. The electromagnet feedback consists of two contacts, one normally closed and one normally open. When the electromagnet is energised the two contacts switch status. The gate feedback consists of two normally closed contacts.

Figure 36 shows the traces relative to the operation. These are described in detail below:

- (1) At this time the user requests to unlock the guard lock. The "COMMAND" signal switches from LL0 to LL1, and the "OUTPUT1" signal switches from LL1 to LL0.
- (2) At this time the electromagnet is activated with a delay of "Unlock Time", after the command is sent. This delay has been set to 0.5 seconds. The "ACTIV." signal switches from LL0 to LL1.
- (3) At this time the electromagnet is actually activated, 95ms after the command was sent. This delay is due to the technical characteristics of the electromagnet. In any case, 95ms is less than 100ms ("Feedback Time") and so no errors have occurred.
- (4) At this time the guard lock is unlocked and the user opens the gate, the FBK_GATE signal switches from LL1 to LL0.
- (5) At this time the user closes the gate and the FBK_GATE signal thus switches from LL0 to LL1.
- (6) At this time the user releases the unlock gate command. The "Guard Lock" detects the gate closed condition, via the FBK_GATE signal, and sends a command to lock the guard lock. The "ACTIV." signal switches from LL1 to LL0.
- (7) At this time the electromagnet is actually deactivated, approx. 95ms after the command was sent due to the technical characteristics of the device. The guard lock is now locked.
- (8) As soon as the "Guard Lock" operator detects that the guard lock is locked and the gate is closed, the "OUTPUT1" signal switches to LL1.

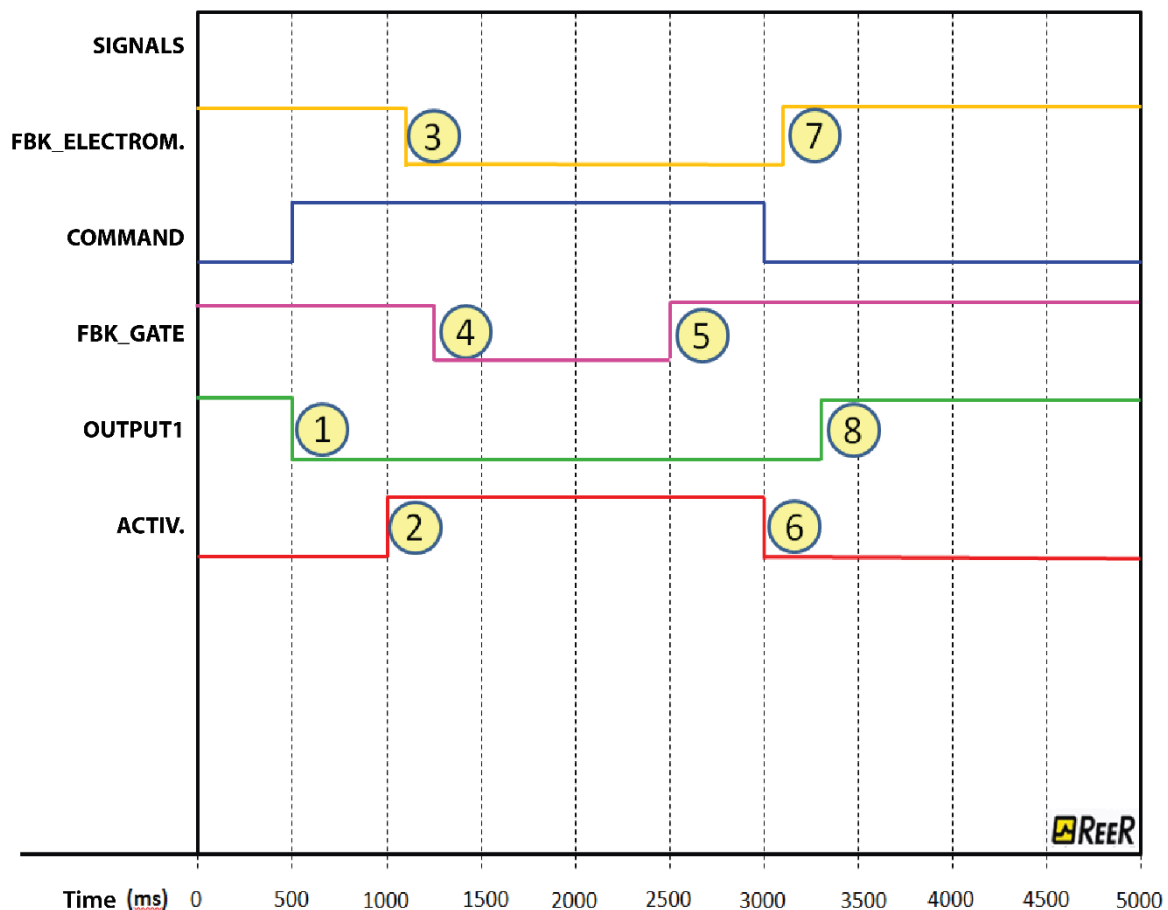

Figure 36 - Traces relative to "Guard Lock" block operation in the with gate mode.

Operation in the "Mandatory Gate Opening" mode

In this case, the user must **NOT** select the "Gate not present" parameter and must select the "Mandatory Gate opening" parameter.

The **Gate** input must always be connected to an "E-GATE" input element (see the E-GATE (safety gate device) section on page 44) that verifies the status of the door/gate. NB: IN THIS OPERATING MODE THE "GATE" INPUT MUST CONFIRM THE OPENING OF THE GATE.



The **Lock_Fbk** input must always be connected to a "LOCK FEEDBACK" input element (see the LOCK FEEDBACK section on page 46) that verifies the status of the guard lock electromagnet.

The **UnLock_cmd** input can be connected freely in the diagram and determines the request to unlock the guard lock (when set to LL1).

The **Output** signal is LL1 (TRUE) if the safety guard is closed and locked. When an unlock command is applied to the **UnLock_cmd** input, the **Output** signal is set to LL0 and the guard lock is unlocked via the **LockOut** signal.

The **Output** signal can also be set to LL0 (FALSE) when error conditions are present (e.g. open door with guard lock locked, **Feedback Time** exceeding the maximum allowed, etc.).

When the **UnLock_cmd** signal is detected, the **LockOut** signal unlocks the guard lock after the *UnLock Time*, a parameter that can be defined by the user.

The time after which the electromagnet is activated depends entirely on the technical/physical characteristics of the specific device and may therefore vary according to the type of guard lock used. Thus, since the the **LockOut** signal controls the activation of this device, the status of the **Lock_Fbk** feedback signal will change at different times, depending on the type of guard lock. This variability can be avoided by changing the value of the *Feedback Time* parameter, which is the maximum delay accepted by the "Guard_Lock" operator before the **Lock_Fbk** signal switches status following a request to activate the electromagnet. Clearly, the following condition must be met:

$$Feedback\ Time \geq Electromagnet\ activation\ time$$

This will now be explained using a practical example.

Example of operation in the "Mandatory Gate Opening" mode

In this example the user unlocks the guard lock with the "SWITCH" block. The "LockOut" signal controls a "STATUS" SIL 1/PL c output that controls the guard lock electromagnet, the status of which is detected by the "LOCK FEEDBACK" input block. "Output1" indicates the status of the operations.

The status of the safety gate is monitored by the "Gate" input via the "E_GATE" input block, the "Mandatory Gate opening" parameter is selected.

The guard lock used in the example continues to be locked when the electromagnet is not energised. Hence the "Interlock spring" option must be selected.

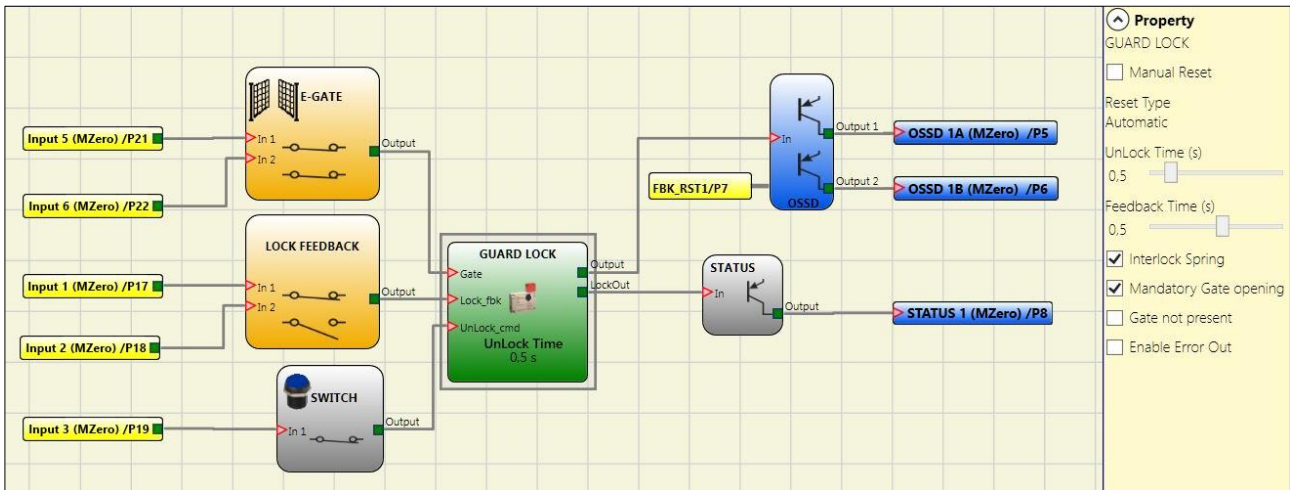

Figure 37 Example of operation in the Mandatory Gate Opening mode

➔ The Guard Lock operator parameters are shown on the right. On the left there is an example of an application diagram. The electromagnet feedback consists of two contacts, one normally closed and one normally open. When the electromagnet is energised the two contacts switch status. The gate feedback consists of two normally closed contacts.

Figure 38 shows the traces relative to the operation. These are described in detail below:

- (1) At this time the user requests to unlock the guard lock. The "COMMAND" signal switches from LL0 to LL1, and the "Output1" signal switches from LL1 to LL0.
- (2) At this time the electromagnet is activated with a delay of "Unlock Time", after the command is sent. This delay has been set to 0.5 seconds. The "ACTIV." signal switches from LL0 to LL1.
- (3) At this time the electromagnet is actually activated, 95ms after the command was sent. This delay is due to the technical characteristics of the electromagnet. In any case, 95ms is less than 100ms ("Feedback Time") and so no errors have occurred.
- (4) At this time the guard lock is unlocked and the user opens the gate. The FBK_GATE signal switches from LL1 to LL0.
- (5) At this time the user closes the gate and the FBK_GATE signal thus switches from LL0 to LL1.
- (6) At this time the user releases the unlock gate command. The "Guard Lock" detects the gate closed condition, via the FBK_GATE signal, and sends a command to lock the guard lock. The "ACTIV." signal switches from LL1 to LL0.
- (7) At this time the electromagnet is actually deactivated, approx. 95ms after the command was sent due to the technical characteristics of the device. The guard lock is now locked.
- (8) As soon as the "Guard Lock" operator detects that the guard lock is locked and the gate is closed, the "Output1" signal switches to LL1.

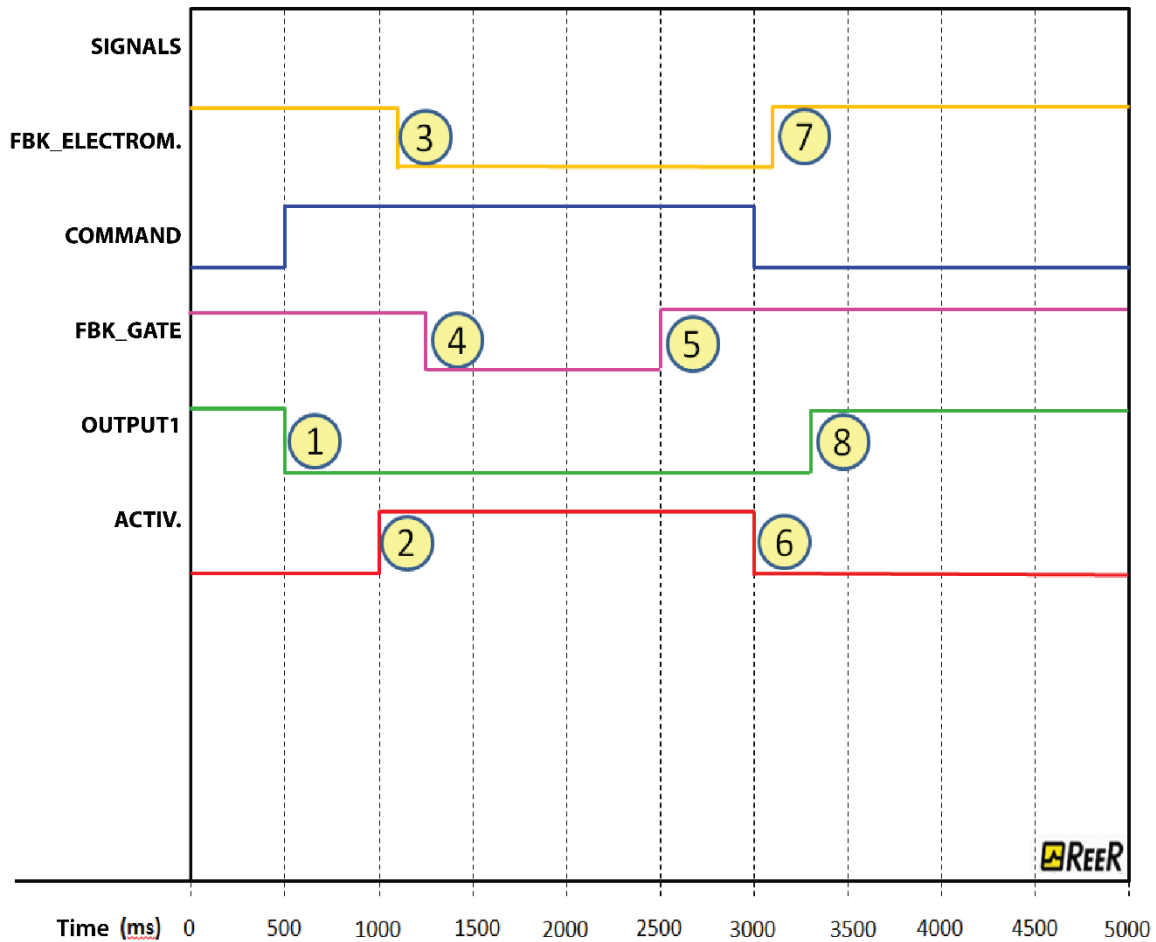

Figure 38 - Traces relative to "Guard Lock" block operation in the "Mandatory gate opening mode".

In "Mandatory gate opening" mode, the "Guard_lock" operator indicates an error condition if it does not detect that the gate has been opened following a request to unlock the guard lock. This concept is highlighted in the figure below (Figure 39). In this case, the "Enable Error out" option has been selected in the diagram in Figure 37, so that the error is shown in the graph.

As previously described, the operator requests unlocking of the guard lock, but the door is never opened, and this condition is indicated by the "FBK_GATE" signal, which stays at LL1. Thus, when the guard lock unlocking/locking cycle ends, at time "E", the "Guard_Lock" operator switches the status of the "ERROR" signal from LL0 to LL1.

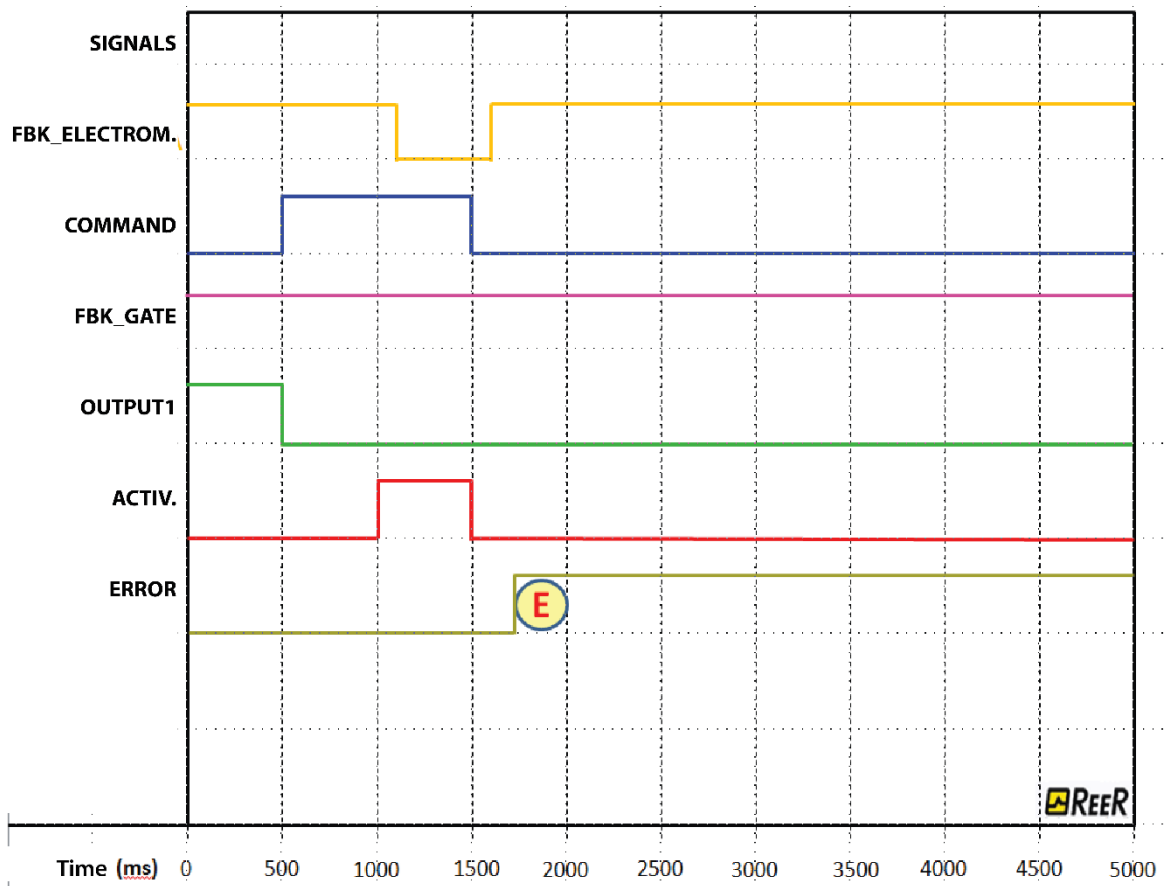

Figure 39 – Example of possible error condition in "Mandatory gate opening" mode. In this case the error condition is generated because the gate has not been opened, even though a request has been sent to unlock/lock the guard lock.

COUNTER OPERATORS

COUNTER (max number = 16)

COUNTER operator is a pulse counter that sets output Q to 1 (TRUE) as soon as the desired count is reached.

There are 3 operating modes:

- 1) AUTOMATIC
- 2) MANUAL
- 3) AUTOMATIC + MANUAL

Following are illustrated 3 examples for each operating mode. The counter value is 6 for all examples.

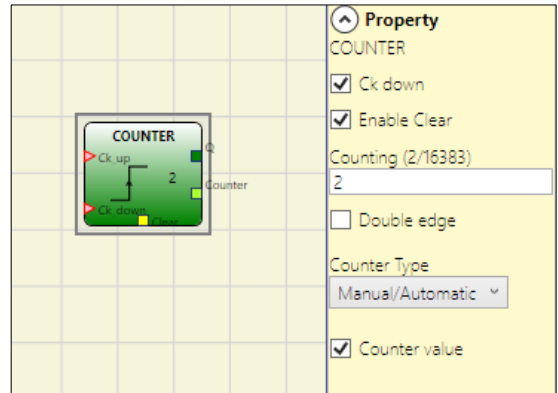

- 1) **AUTOMATIC:** The counter generates a pulse duration equal to $2 \times T_{\text{cycle}}$ (this value is indicated in the REPORT) as soon as the set count is reached. If the CLEAR pin is not enabled this is the default mode.

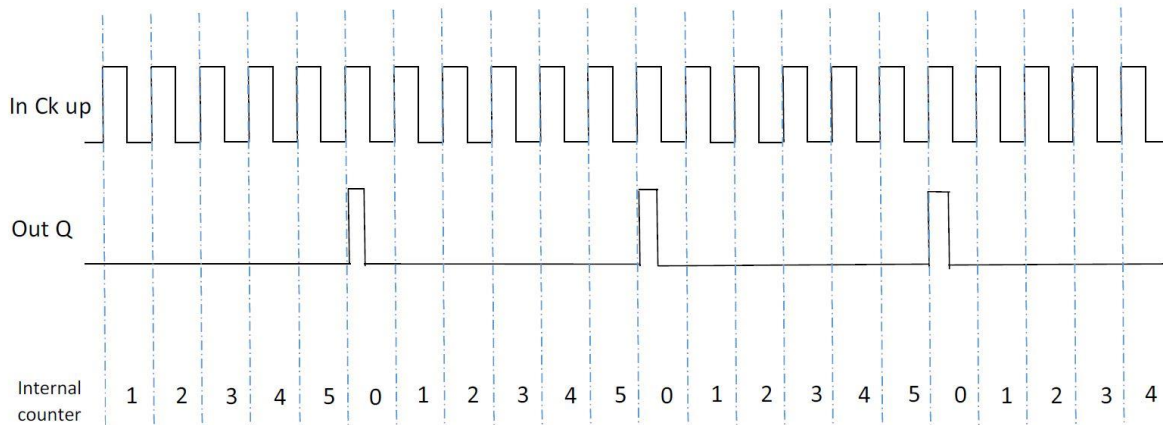

- 2) **MANUAL:** The counter leads to 1 (TRUE) the output Q as soon as it reaches the set count. The output Q goes to 0 (FALSE) when the signal CLEAR is activated.

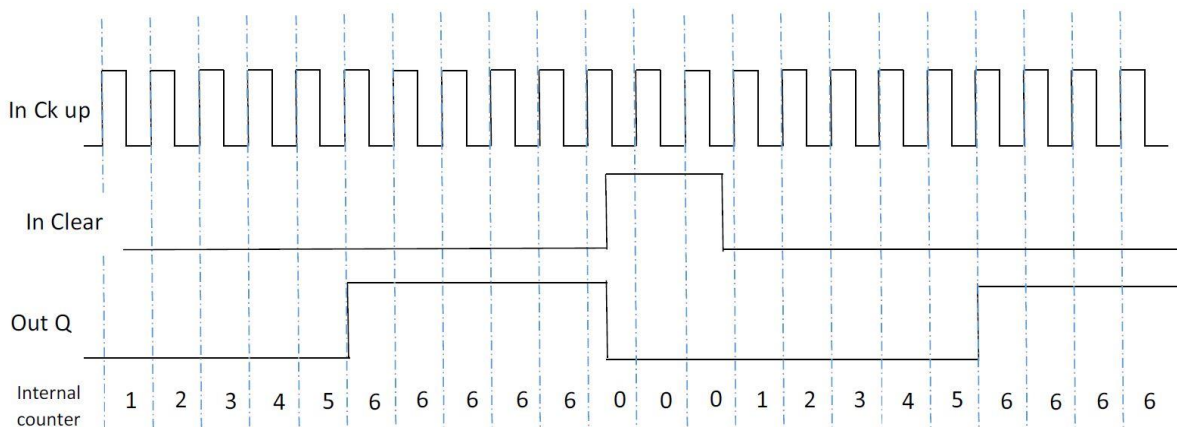

3) MANUAL/AUTOMATIC: The counter generates a pulse duration equal to the system response time as soon as the set count is reached. If the CLEAR signal is activated, the internal count goes back to 0.

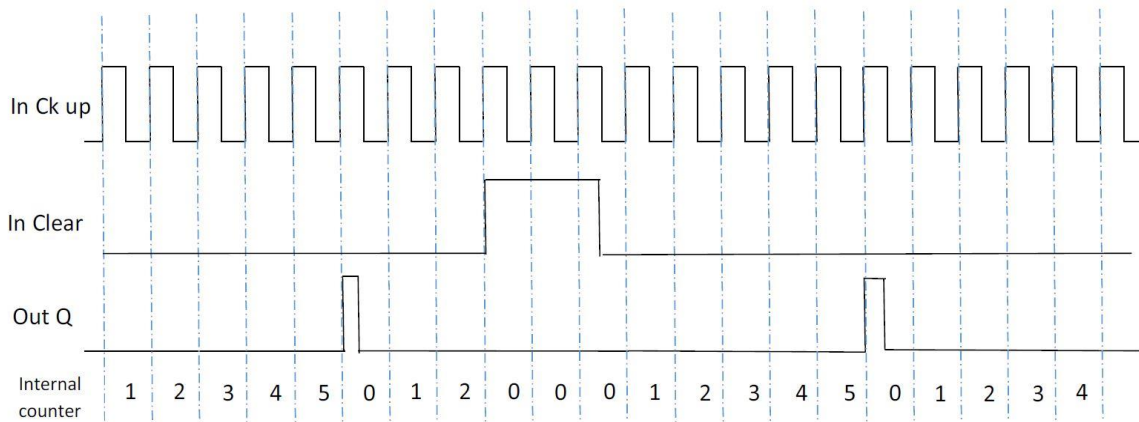

Parameters

Enable Clear: If selected enables the signal CLEAR in order to restart the counter setting output Q to 0 (FALSE). It also offers the possibility to select the operation mode.

Counter type: If ENABLE CLEAR is not selected operation is AUTOMATIC (example 1).

If ENABLE CLEAR is selected, operation is selectable between MANUAL (example 2) or MANUAL/AUTOMATIC (example 3).

Ck down: Enables counting down.

Two-way: If selected it enables counting on both the rising and falling edges.

Counter value: If selected, it allows the current counter value to be outputted from the delay block. This output can be sent as input to one or more COUNTER COMPARATOR blocks.

COUNTER COMPARATOR

Gets as an input the counter value of an operator COUNTER and compares the received value with a threshold set by the user. The OUT output will be 0 (FALSE) as long as the COUNTER value is lower than the threshold value. The OUT output will be set to 1 (TRUE) for COUNTER values equal to or higher than the threshold value.

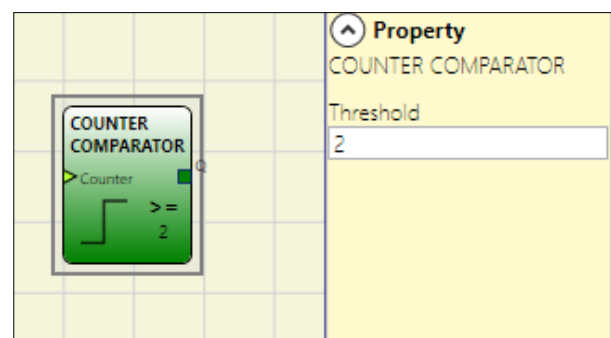

→ The COUNTER COMPARATOR operator can only be connected to the Counter value of a COUNTER operator. Multiple COUNTER COMPARATOR can be also connected to a single COUNTER operator.

TIMER OPERATORS (max number = 32)

TIMER operators allow you to generate a signal (TRUE or FALSE) for a user-definable period.

MONOSTABLE

The MONOSTABLE operator generates a level 1 (TRUE) output activated by the rising edge of the input and remains in this condition for the set time.

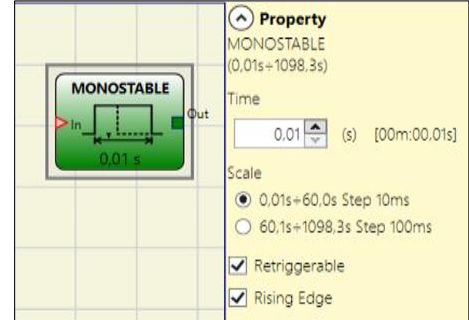

Parameters

Time: The delay can be set to between 10 ms and 1098,3 s.

Scale: The user can choose two different scales for the time T to be set.

- 10 ms...60 s, step 10 ms
- 60,1 s...1098,3 s, step 100 ms

Rising edge: If selected, the output is set to 1 (TRUE) on the input signal's rising edge where it remains for the set time, which can be extended for as long as the input stays at 1 (TRUE).

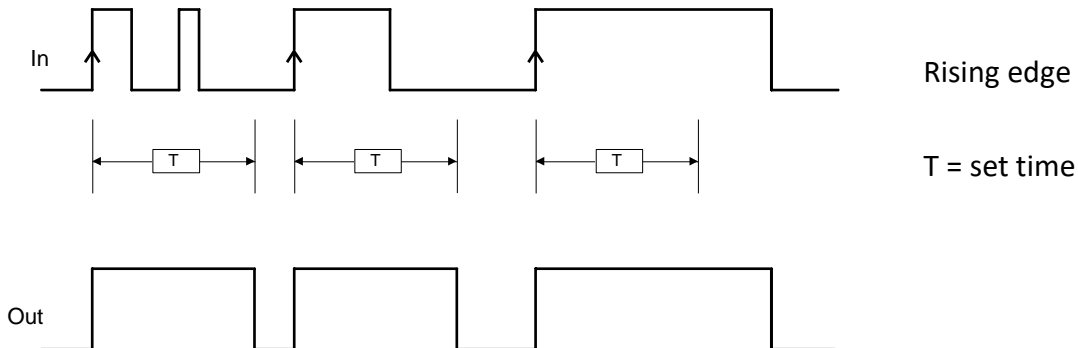

If not selected the logic is inverted, the output is set to 0 (FALSE) on the input signal's falling edge, where it remains for the set time, which can be extended for as long as the input stays at 0 (FALSE).

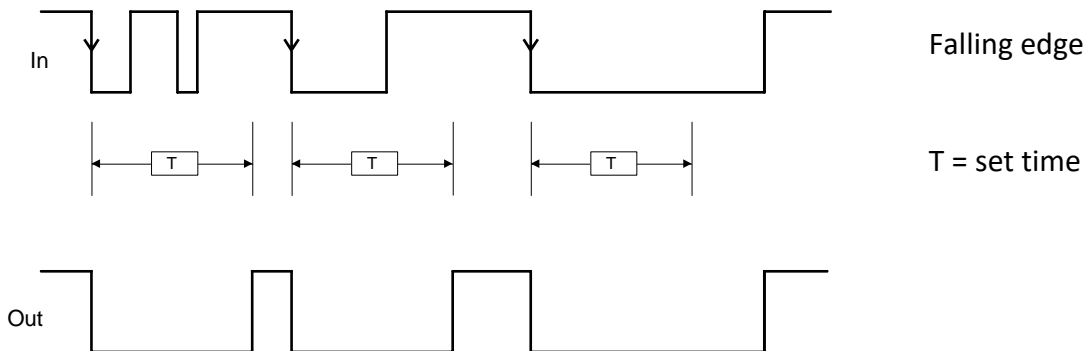

Retriggerable: If selected the time is reset each time the input status changes.

MONOSTABLE_B

This operator generates a level 1 (TRUE) output activated by the rising/falling edge of the input and remains in this condition for the set time t .

Parameters

Time: The delay can be set to between 10 ms and 1098,3 s.

Scale: The user can choose two different scales for the time T to be set.

- 10 ms...60 s, step 10 ms
- 60,1 s...1098,3 s, step 100 ms

Rising edge:

- If selected provides a level 1 (TRUE) in the OUT output if a **rising edge** is detected on the IN input.
- If not selected the logic is inverted, the OUT output is set to 0 (FALSE) on the IN signal's falling edge, where it remains for the set time.

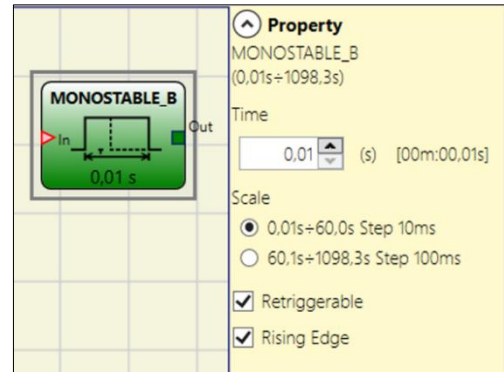

➔ Unlike the MONOSTABLE operator, the Out output of MONOSTABLE_B does not maintain a level 1 (TRUE) for a time which exceeds the set period T .

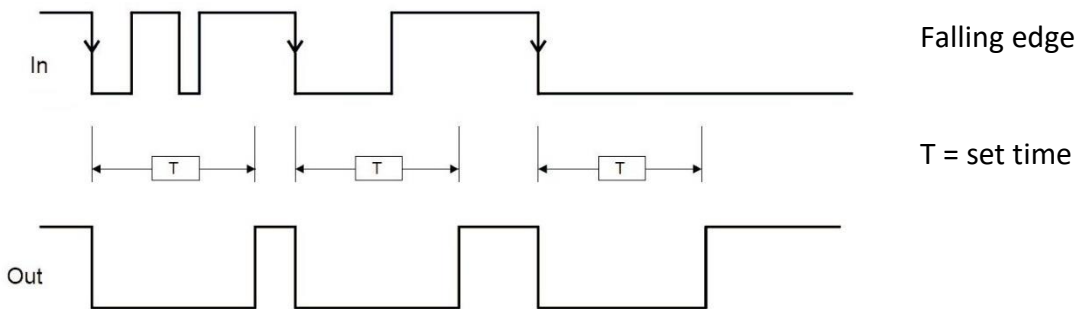
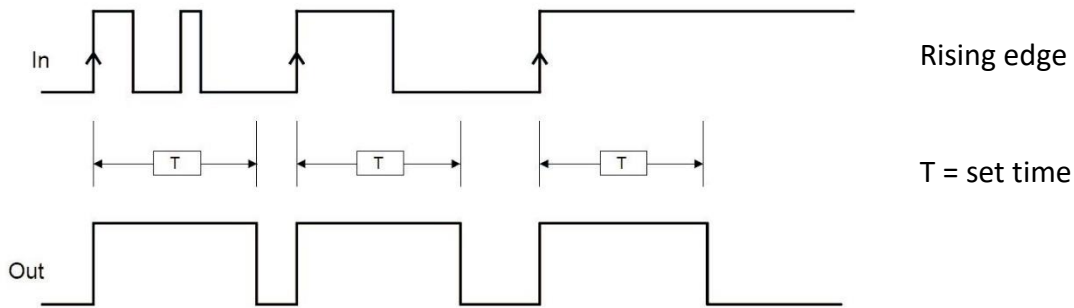

Retriggerable: If selected the time is reset each time the input status changes.

PASSING MAKE CONTACT

In the PASSING MAKE CONTACT operator the output follows the signal on the input. However, if this is 1 (TRUE) for longer than the set time, the output changes to 0 (FALSE). When there is an input falling edge, the timer is cleared.

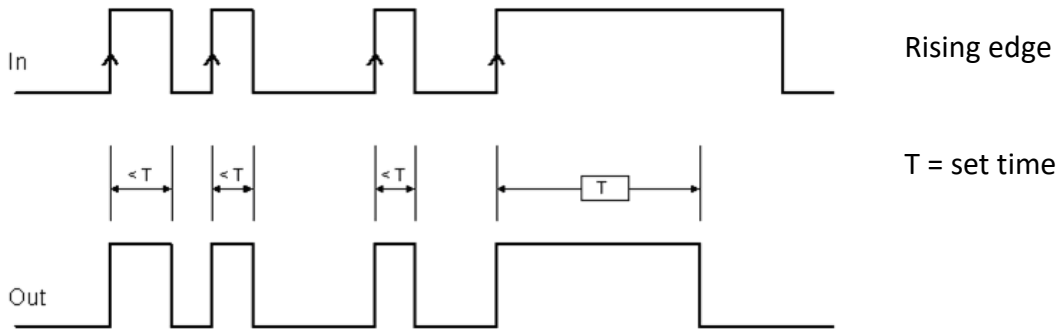
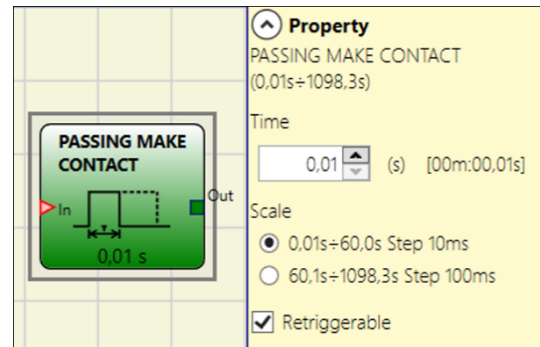

Parameters

Time: The delay can be set to between **10 ms and 1098,3 s**.

Scale: The user can choose two different scales for the time *T* to be set.

- 10 ms...60 s, step 10 ms
- 60,1 s...1098,3 s, step 100 ms

Retriggerable: If selected the time is not reset when there is an input falling edge. The output stays 1 (TRUE) for all the selected time. When there is a new input rising edge, the timer restart again.

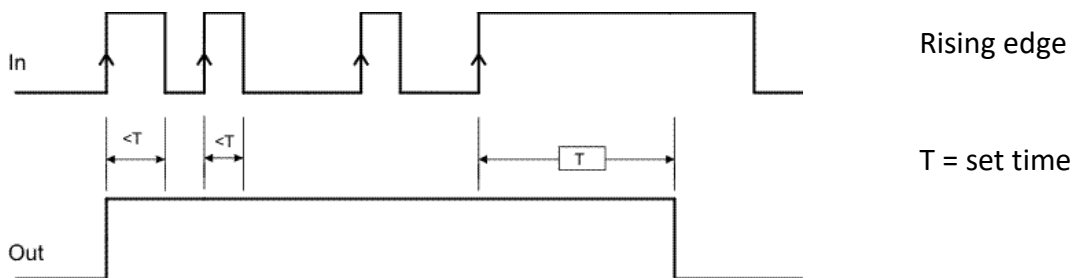

DELAY

DELAY operator applies a delay to a signal by setting the output to 1 (TRUE) after the set time, against a change in the level of the input signal.

Parameters

Time: The delay can be set to between **10 ms and 1098,3 s**.

Scale: The user can choose two different scales for the time T to be set.

- 10 ms...60 s, step 10 ms
- 60,1 s...1098,3 s, step 100 ms

Rising edge: If selected, the delay starts on the input signal's rising edge at the end of which the output changes to 1 (TRUE) if the input is 1 (TRUE) where it remains for as long as the input stays at 1 (TRUE).

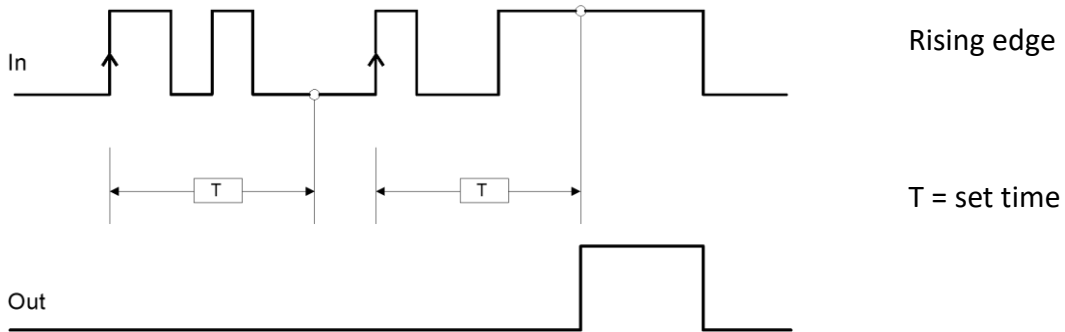

If not selected the logic is inverted, the output is set to 1 (TRUE) on the input signal's falling edge, at the end of the set time the output changes to 0 (FALSE) if the input is 0 (FALSE) otherwise it remains 1 TRUE.

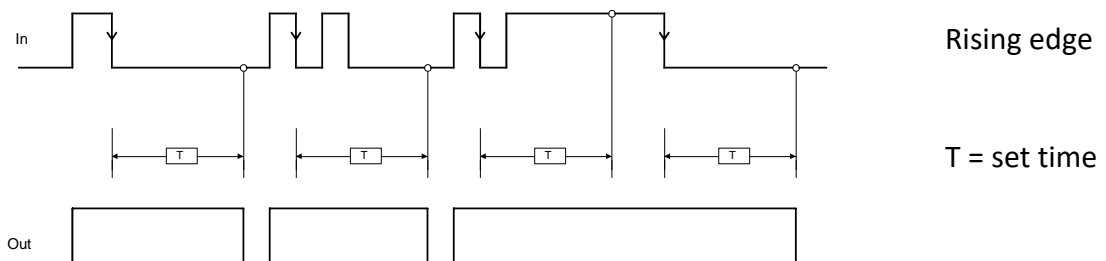

Retriggerable: If selected the time is reset each time the input status changes.

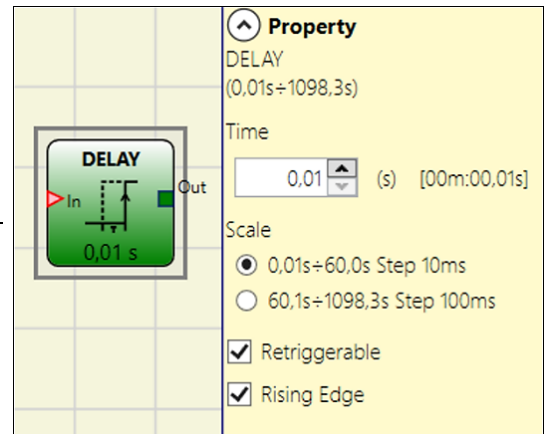

LONG DELAY

The LONG DELAY operator allows to apply a delay (up to more than 15 hours) to a signal bringing to 1 (TRUE) the Out output after the set time, in case of a level variation of the signal on the In input.

Parameters

Time: The delay can be set from 0.5 s to 54915 s.

Scale: The user can choose two different scales for the time T to be set.

- 0,5 s...3000 s, step 0,5 s
- 3005 s...54915 s, step 5 s

Rising edge: If selected, the delay starts on the input signal's rising edge at the end of which the output changes to 1 (TRUE) if the input is 1 (TRUE) where it remains for as long as the input stays at 1 (TRUE).

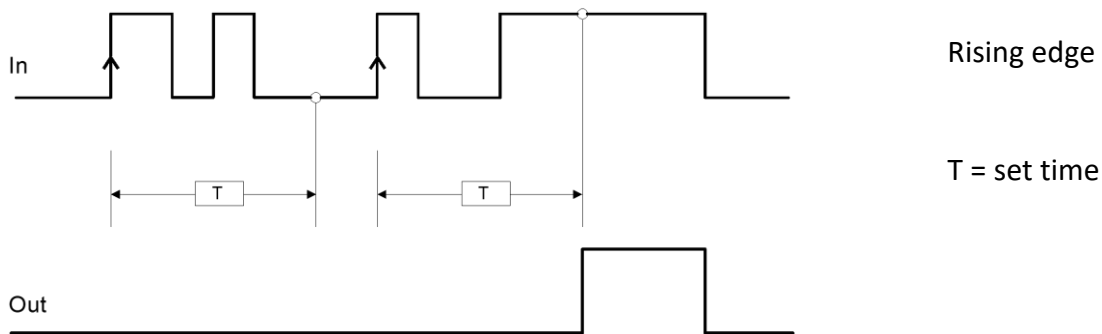

If not selected the logic is inverted, the output is set to 1 (TRUE) on the input signal's falling edge, at the end of the set time the output changes to 0 (FALSE) if the input is 0 (FALSE) otherwise it remains 1 TRUE.

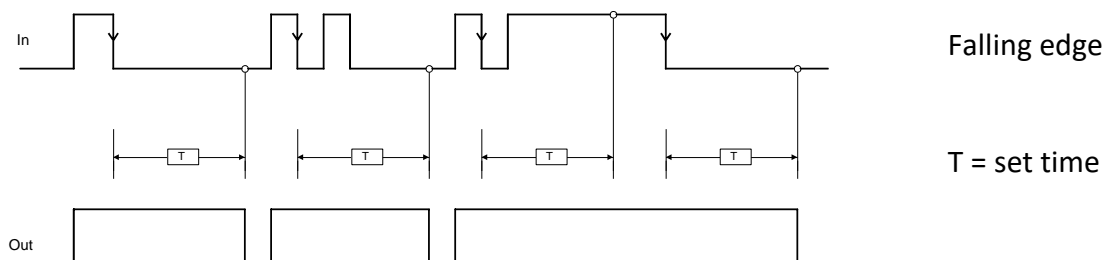

Retriggerable: If selected the time is resetted every time the input status changes.

Timer value: When selected the actual value of the timer is available as output which can be sent as input to a DELAY COMPARATOR block.

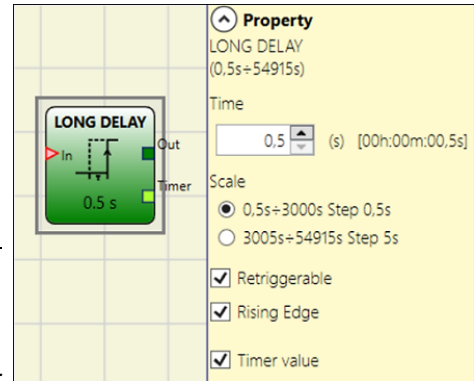

DELAY COMPARATOR

This operator compares the timer value outputted by a LONG DELAY timer and connected to the DELAY COMPARATOR "Timer" input with the set threshold value.

The OUT output will be 0 (FALSE) as long as the timer value is lower than the threshold value. The OUT output will be set to 1 (TRUE) for Timer values equal to or higher than the threshold value.

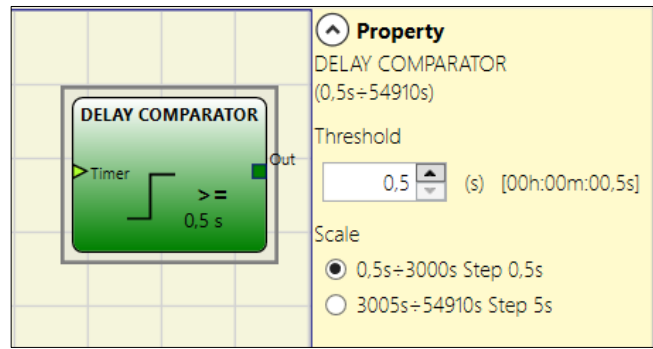

Parameters

Threshold: The threshold can be set from 0,5 s to 54910 s.

Scale: The user can choose two different scales for the time T to be set.

- 0,5 s...3000 s, step 0,5 ms
- 3005 s...54910 s, step 5 s

➔ The Delay Comparator operator can only be connected to the Timer value output of a LONG DELAY operator. Multiple DELAY COMPARATORS can be connected to each LONG DELAY operator.

DELAY LINE

This operator applies a delay to a signal by setting the "Out" output to 0 (FALSE) after the set time when a falling edge is detected on the "In" signal.

If "In" returns to 1(TRUE) before the end of the set time the "Out" output still generates a negative impulse lasting approximately twice the system response time and delayed by the set time.

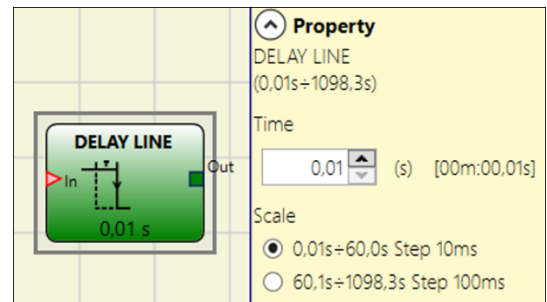

Parameters

Time: The delay can be set to between 10 ms and 1098,3 s.

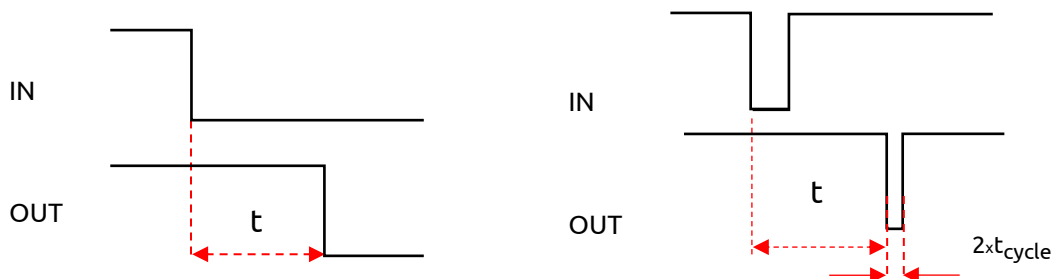

Scale: The user can choose two different scales for the time T to be set.

- 10 ms...60 s, step 10 ms
- 60 s...1098,3 s, step 100 ms

- ➔ Unlike the DELAY operator, the DELAY LINE operator does not filter any interruptions in the IN input which are shorter than the set time.
- ➔ This operator is recommended when using delayed OSSD (the OSSD must be programmed with RESTART MANUAL).

LONG DELAY LINE

This operator applies a delay to a signal by setting the "Out" output to 0 (FALSE) after the set time when a falling edge is detected on the "In" signal.

If In returns to 1 (TRUE) before the end of the set time the "Out" output still generates a negative impulse lasting approximately twice the system response time and delayed by the set time.

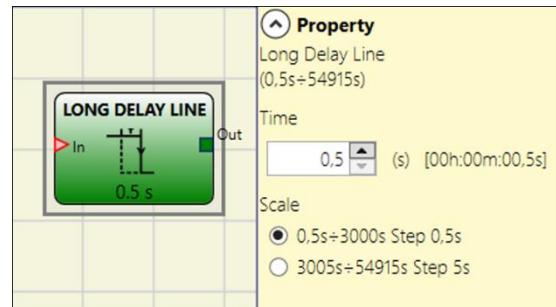

Parameters

Time: The delay can be set from 0.5 s to 54915 s.

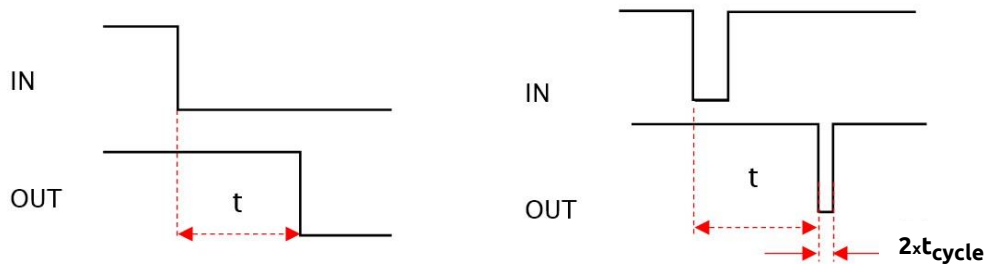

Scale: The user can choose two different scales for the time T to be set.

- 0,5 s...3000 s, step 0,5 s
- 3005 s...54915 s, step 5 s

- ➔ Unlike the DELAY operator, the LONG DELAY LINE operator does not filter out any interruptions to the IN input that are shorter than the set time.
- ➔ This operator is useful when using delayed OSSDs (the OSSD must be programmed with MANUAL RESTART).

CLOCKING

The CLOCKING operator generates a square wave output which period is set by the user. The output is enabled if the "En" input is set to 1 (TRUE). Clocking has up to 7 inputs to control output Duty Cycle.

Parameters

Time: The period can be set to between 100 ms and 1098,3 s.

Scale: The user can choose two different scales for the time *T* to be set.

- 100 ms...60 s, step 10 ms
- 60,1 s...1098,3 s, step 100 ms

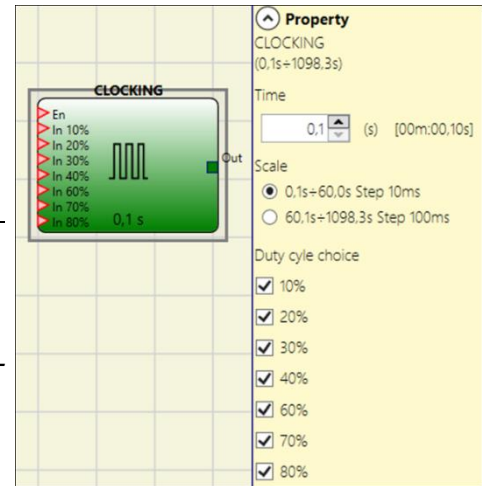

Duty cycle selection: Up to 7 inputs can be selected for 7 different output signal duty cycles. Depending on the active input, the OUT clock signal has its corresponding duty cycle. EN input must always be to 1 (TRUE).

Refer to the table below for all possible values of Duty cycle selectable by the user.

DUTY CYCLE CHOICE								
EN	10%	20%	30%	40%	60%	70%	80%	OUT
0	0	0	0	0	0	0	0	0
1	0	0	0	0	0	0	0	50%
1	1	0	0	0	0	0	0	10%
1	0	1	0	0	0	0	0	20%
1	0	0	1	0	0	0	0	30%
1	0	0	0	1	0	0	0	40%
1	0	0	0	0	1	0	0	60%
1	0	0	0	0	0	1	0	70%
1	0	0	0	0	0	0	1	80%
1	1	0	0	0	0	0	1	90%

- ➔ The circuit upstream clocking operator must ensure the presence of only one input signal in addition to enable EN (excluded the pair 10% 80%).
- ➔ The presence on EN input of high level (TRUE), generates an output signal with a duty cycle = 50%.

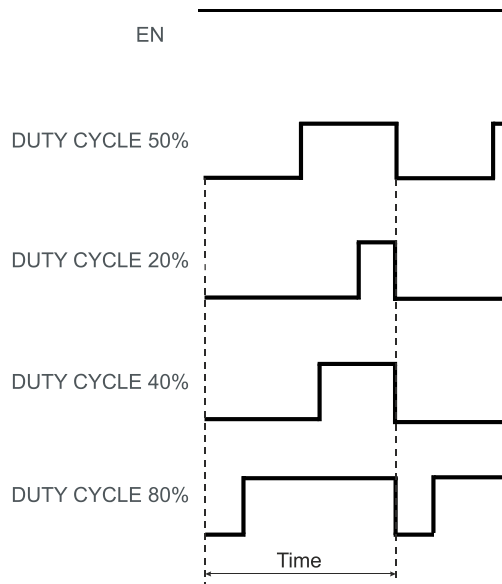

MUTING FUNCTION

The Muting function generates a temporary, automatic interruption of electro-sensitive protective device (ESPE) operation in order to permit normal transit of material through the guarded opening. In other words, when the system recognizes the material and distinguishes between this and any operator (in a potentially dangerous situation), it is enabled to bypass the safety device temporarily, allowing the material to pass through the guarded opening.

MUTING OPERATORS (max number = 4)

"Concurrent" MUTING

The activation of the Muting function occurs following interruption of the sensors S1 and S2 beam (the order does not matter) within a time range from 2s and 5s chosen by the operator (or S3 and S4 with material that is moving in the direction opposite).

The MUTING operator with "Concurrent" logic performs muting of the input signal through sensor inputs S1, S2, S3 and S4.

➔ Preliminary condition: The Muting cycle can only start if all the sensors are 0 (FALSE) and inputs are 1 (TRUE) (safety curtain free).

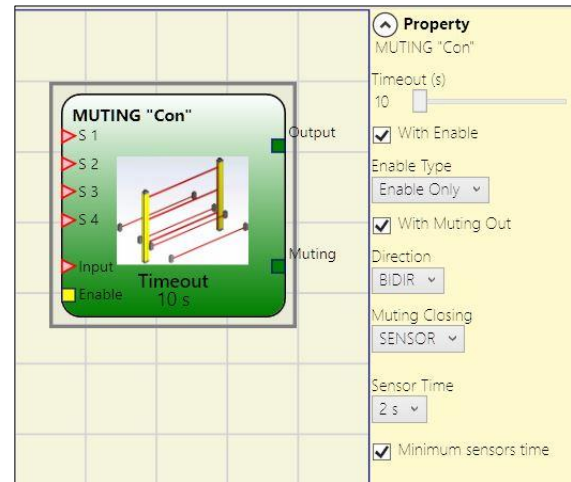

Parameters

Timeout (sec): Sets the time, between 10 secs and unlimited, within which the Muting cycle must end. If the cycle is not complete at the end of this time, Muting is immediately discontinued.

With Enable: When checked let the user the possibility of enabling or not enabling the Muting function. Otherwise the Muting function is always enabled.

Enable Type:

There are two Enable modes: Enable/Disable and Enable Only.

- If "Enable/Disable" is selected the Muting cycle cannot start if Enable is stucked at 1 (TRUE) or 0 (FALSE). It is only activated with a rising edge of the signal. On the other hand the falling edge disables Muting regardless of the current condition.
- If "Enable Only" is selected the Muting function cannot be disabled. It is mandatory to set the "Enable" input to 0 (FALSE) in order to reset this command for a new Muting cycle.

Direction: This let the user to choose the order in which the sensors are occupied. If set to BIDIR they can be occupied in both directions, from S1&S2 to S3&S4 and from S3&S4 to S1&S2, if set to UP they can be occupied from S1&S2 to S3&S4 and if set to DOWN from S3&S4 to S1&S2.

Muting Closing: There are two types, CURTAIN and SENSOR. If you select CURTAIN muting closes when the input signal rises, if you select SENSOR it closes when the third sensor has been cleared.

Select CURTAIN

S1	S2	Input	S3	S4	Muting
0	0	1	0	0	0
1	0	1	0	0	0
1	1	1	0	0	1
1	1	X	0	0	1
1	1	X	1	1	1
0	0	0	1	1	1
0	0	1	1	1	0
0	0	1	0	0	0

Muting active

Select SENSOR

S1	S2	Input	S3	S4	Muting
0	0	1	0	0	0
1	0	1	0	0	0
1	1	1	0	0	1
1	1	X	0	0	1
1	1	X	1	1	1
0	0	0	1	1	1
0	0	1	1	1	1
0	0	1	0	1	0
0	0	1	0	0	0

Muting active

Blind Time: Only with Muting Close=Curtain, blind time is enabled when it is known that after a complete transition of the pallet (muting cycle close) some protruding objects could still occupy the light curtain and send the input to 0 (FALSE). During blind time the input remains 1 (TRUE). Blind Time can range from 250 ms to 1 second.

Sensors Time: Sets the **maximum time** (between 2 and 5 seconds) between activating two muting sensors.

Minimum sensors time: If selected, allows the activation of Muting cycle only if a time ≥ 150 ms elaps between the activation of the sensor 1 and sensor 2 (or sensor 4 and 3).

MUTING "L"

The activation of the Muting function occurs following interruption of the sensors S1 and S2 beam (the order does not matter) within a time range from 2s and 5s decided by the operator. The state of the Muting ends after the liberation of the guarded opening.

The MUTING operator with "L" logic performs muting of the input signal through sensor inputs S1 and S2.

➔ Preliminary condition: The Muting cycle can only start if S1 and S2 are 0 (FALSE) and the input = 1 (TRUE) (safety curtain free).

Parameters

Timeout (sec): Sets the time, between 10 secs and unlimited, within which the Muting cycle must end. If the cycle is not complete at the end of this time, Muting is immediately discontinued.

With Enable: When checked let the user the possibility of enabling or not enabling the Muting function. Otherwise the Muting function is always enabled.

Enable Type:

There are two Enable modes: Enable/Disable and Enable Only.

- If "Enable/Disable" is selected the Muting cycle cannot start if Enable is stucked at 1 (TRUE) or 0 (FALSE). It is only activated with a rising edge of the signal. On the other hand the falling edge disables Muting regardless of the current condition.
- If "Enable Only" is selected the Muting function cannot be disabled. It is mandatory to set the "Enable" input to 0 (FALSE) in order to reset this command for a new Muting cycle.

Sensors Time: Sets the **maximum time** (between 2 and 5 seconds) between activating two muting sensors.

End of Muting time: sets the **maximum time** (from 2.5 to 6 seconds) that must elapse between the release of the first sensor and the release of guarded opening. The end of this time determines the end of the Muting function.

Blind Time: enabled when it is known that after a complete transition of the pallet (muting cycle close) some protruding objects could still occupy the light curtain and send the input to 0 (FALSE). During blind time the input remains 1 (TRUE). Blind Time can range from 250 ms to 1 second.

"Sequential" MUTING

The activation of the Muting function occurs following sequential interruption of the sensors S1 and S2, subsequently S3 and S4 sensors (without time limit). If the pallet proceeds in the opposite direction the correct sequence is: S4, S3, S2, S1.

The MUTING operator with "Sequential" logic performs muting of the input signal through sensor inputs S1, S2, S3 and S4.

➔ Preliminary condition: The Muting cycle can only start if all the sensors are 0 (FALSE) and the input = 1 (TRUE) (safety curtain free).

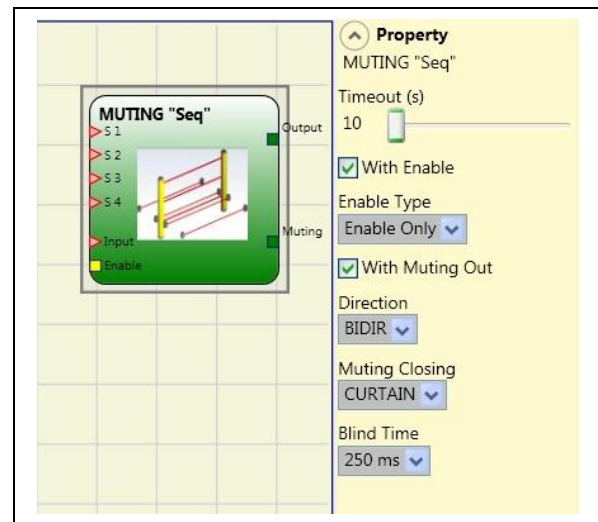

Parameters

Timeout (sec): Sets the time, between 10 secs and unlimited, within which the Muting cycle must end. If the cycle is not complete at the end of this time, Muting is immediately discontinued.

With Enable: When checked let the user the possibility of enabling or not enabling the Muting function. Otherwise the Muting function is always enabled.

Enable Type:

There are two Enable modes: Enable/Disable and Enable Only.

- If "Enable/Disable" is selected the Muting cycle cannot start if Enable is stucked at 1 (TRUE) or 0 (FALSE). It is only activated with a rising edge of the signal. On the other hand the falling edge disables Muting regardless of the current condition.
- If "Enable Only" is selected the Muting function cannot be disabled. It is mandatory to set the "Enable" input to 0 (FALSE) in order to reset this command for a new Muting cycle.

Direction: This let the user to choose the order in which the sensors are occupied. If set to BIDIR they can be occupied in both directions, from S1 to S4 and from S4 to S1, if set to UP they can be occupied from S1 to S4 and if set to DOWN from S4 to S1.

Muting Closing: There are two types, CURTAIN and SENSOR. If you select CURTAIN muting closes when the input signal rises, if you select SENSOR it closes when the third sensor has been cleared.

Select CURTAIN

S1	S2	Input	S3	S4	Muting
0	0	1	0	0	0
1	0	1	0	0	0
1	1	1	0	0	1
1	1	X	0	0	1
1	1	X	1	0	1
1	1	X	1	1	1
0	1	X	1	1	1
0	0	0	1	1	1
0	0	1	1	1	0
0	0	1	0	1	0
0	0	1	0	0	0

Muting active

Select SENSOR

S1	S2	Input	S3	S4	Muting
0	0	1	0	0	0
1	0	1	0	0	0
1	1	1	0	0	1
1	1	X	0	0	1
1	1	X	1	0	1
1	1	X	1	1	1
0	1	X	1	1	1
0	0	0	1	1	1
0	0	1	1	1	1
0	0	1	0	1	0
0	0	1	0	0	0

Muting active

Blind Time: **Only with Muting Close=Curtain**, blind time is enabled when it is known that after a complete transition of the pallet (muting cycle close) some protruding objects could still occupy the light curtain and send the input to 0 (FALSE). During blind time the input remains 1 (TRUE). Blind Time can range from 250 ms to 1 second.

MUTING "T"

The activation of the Muting function occurs following interruption of the sensors S1 and S2 beam (the order does not matter) within a time range from 2s and 5s decided by the operator. The state of the Muting ends after the liberation of at least one of the two sensors.

The MUTING operator with "T" logic performs muting of the input signal through sensor inputs S1 and S2.

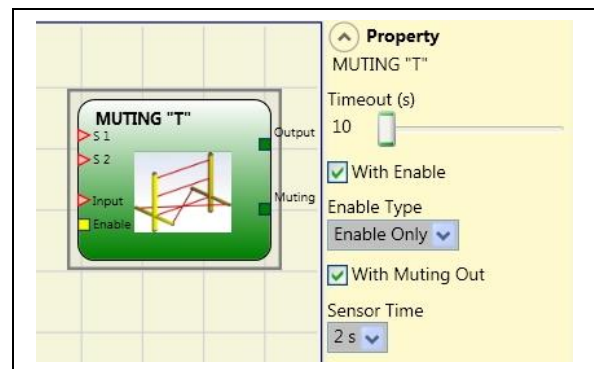

➔ Preliminary condition: The Muting cycle can only start if S1 and S2 are 0 (FALSE) and the inputs are 1 (TRUE) (safety curtain free).

Parameters

Timeout (sec): Sets the time, between 10 secs and unlimited, within which the Muting cycle must end. If the cycle is not complete at the end of this time, Muting is immediately discontinued.

With Enable: When checked let the user the possibility of enabling or not enabling the Muting function. Otherwise the Muting function is always enabled.

Enable Type:

There are two Enable modes: Enable/Disable and Enable Only.

- If "Enable/Disable" is selected the Muting cycle cannot start if Enable is stuck at 1 (TRUE) or 0 (FALSE). It is only activated with a rising edge of the signal. On the other hand the falling edge disables Muting regardless of the current condition.
- If "Enable Only" is selected the Muting function cannot be disabled. It is mandatory to set the "Enable" input to 0 (FALSE) in order to reset this command for a new Muting cycle.

Sensors Time: Sets the **maximum time** (between 2 and 5 seconds) between activating two muting sensors.

MUTING OVERRIDE (max number = 4)

The **OVERRIDE** function must be used when the machine stops due to incorrect Muting activation sequences with the material obstructing the guarded opening. This function activates the OSSD outputs making it possible to remove the material that is obstructing the guarded opening.

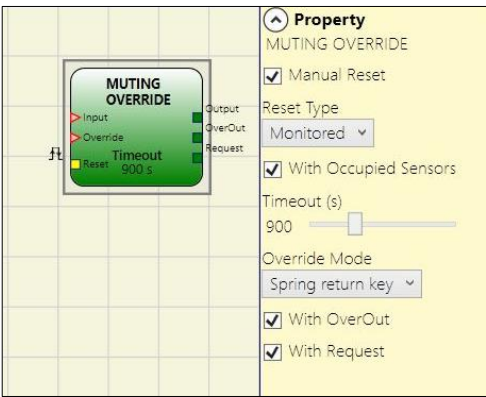

The operator must be connected after the Muting operator (Muting OUTPUT directly to the Override INPUT). It permits override of the directly connected Muting Input.

Override can be activated only if Muting is not active (INPUT=0) and at least one Muting sensor is occupied (or the safety curtain is occupied).

Override ends when the light curtain and sensors are cleared and the OverOut switches to logical 0 (FALSE).

Override can be set to *Spring Return Key* or *Pushbutton*.

Override with spring return key.

This function must be activated maintaining the Override command active (OVERRIDE=1) during all subsequent operations. However, a new Override can be activated, de-activating and re-activating the command.

When the light curtain and sensors are cleared (gap free) or on expiry of the timeout, Override ends without the need for further commands.

Override with pushbutton

This function is enabled activating the Override command (OVERRIDE=1).

Override ends when the light curtain and sensors are cleared (gap free) or on expiry of the timeout. The function can be restarted only if the Override command is reactivated (OVERRIDE=1).

Parameters

With sensors occupied: Must be selected with "T" sequential, simultaneous muting; with "L" muting, must not be selected.

- ➔ Otherwise, a Warning is displayed in the compilation phase and in the report.
- ➔ The user must adopt additional safety measures during the Override phase.

Conditions to be checked for activation of Override

"With occupied sensors" selected	Occupied sensor	Light curtain occupied	Input	Override request	Override output
X	X	-	0	1	1
-	-	X	0	1	1
	X	-	0	1	1
	X	X	0	1	1

Timeout (sec): Used to set the time, between 10 sec and infinity, by which the Override function must end.

Override mode: Used to configure the type of Override (pulsed or maintained action).

With OverOut: Used to activate an Override active Signaling output (active when high).

With Request: Used to activate a Signaling output (active when high) indicating that the Override function can be activated.

Manual Reset:

- Should the INPUT be active (TRUE), the reset enables the output of the function block.
- Should the INPUT be not active (FALSE), the output of the function block follows the OVERRIDE request.

There are two types of reset: Manual and Monitored. When Manual is selected the system only verifies the signal's transition from 0 to 1. If Monitored is selected the double transition from 0 to 1 and then back to 0 is verified.

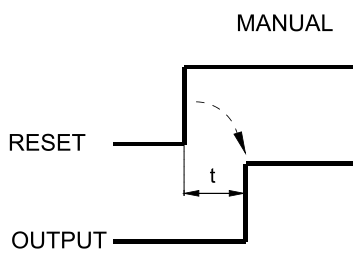

$t = 250 \text{ ms}$

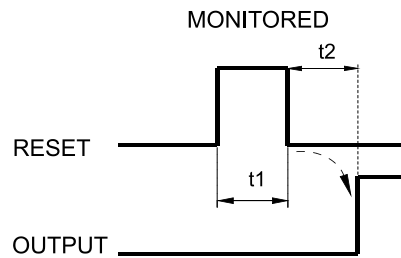

$5s > t1 > 250 \text{ ms}$
 $t2 = 250 \text{ ms}$

MISCELLANEOUS FUNCTION BLOCKS

SERIAL OUTPUT (max number = 8)

The **Serial Output** operator outputs the status of up to 8 inputs, serialising the information.

Operating principles.

This operator outputs the status of all the connected inputs in two different ways:

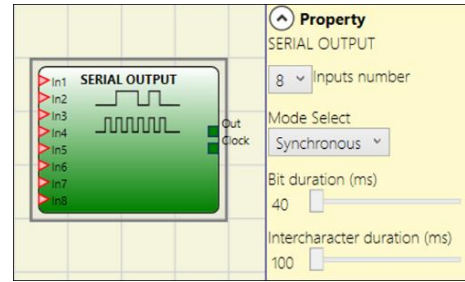

Asynchronous serialisation:

- 1) The status of the line in the idle condition is 1 (TRUE);
- 2) The start data transmission signal is 1 bit = 0 (FALSE);
- 3) Transmission of n bits with the status of the connected inputs encoded using the *Manchester* method:
 - Status 0: rising edge of the signal at the centre of the bit
 - Status 1: falling edge of the signal at the centre of the bit
- 4) Intercharacter interval is 1 (TRUE) to allow synchronisation of an external device.

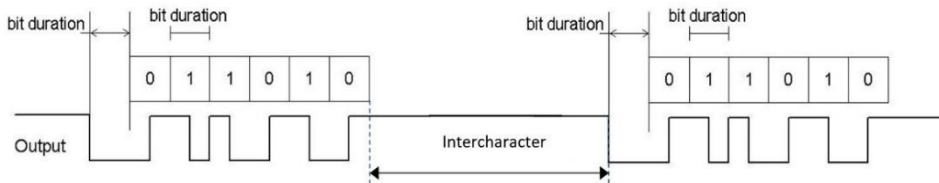

➔ With the Asynchronous method the *Clock* output is not present.

Synchronous serialisation:

- 1) The output and the clock in the idle condition are 0 (FALSE);
- 2) Transmission of n bits with the input status using OUTPUT as data, CLOCK as the timing base;
- 3) Intercharacter interval is 0 (FALSE) to allow synchronisation of an external device.

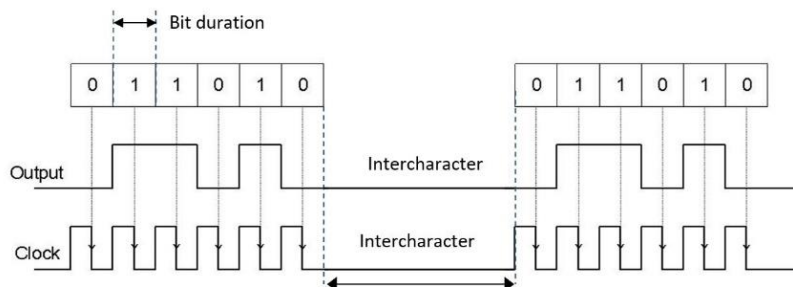

Parameters

Inputs number: Defines the number of inputs of the function block, which may be 2...8 (*asynchronous*) or 3...8 (*synchronous*).

Mode select: The user can choose two ways of transmission: Asynchronous and Synchronous. Please refer to "Operating principles" at the top of this page.

Bit length (ms): Enter the value corresponding to the length of each single bit (input n) in the pulse train that makes up the transmission.

- 40 ms...200 ms (Step 10 ms)
- 250 ms...0.95 s (Step 50 ms)

Intercharacter interval (ms): Enter the time that must pass between the transmission of one pulse train and the next.

- 100 ms...2.5 s (Step 100 ms)
- 3 s...6 s (Step 500 ms)

NETWORK (max number = 1)

The **Network** operator is used to distribute Stop and Reset commands via a simple local network. Use **Network_in** and **Network_out** to exchange **START**, **STOP** and **RUN** signals between the different nodes.

Operating principles.

This operator allows stop and reset commands to be simply distributed in a local MZERO network.

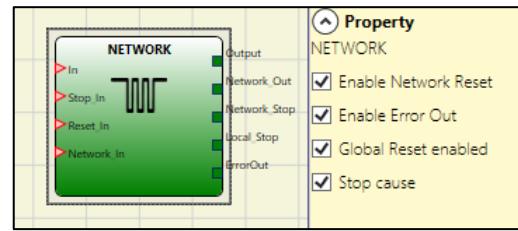

The Network operator requires the following:

- 1) the **Network_In** input (single or double) must be connected to the **Network_Out** output of the preceding unit in the local network.
- 2) the **Network_Out** (could be a STATUS or OSSD output), must be connected to the **Network_in** input of the next unit in the local network.
- 3) the **Stop_In** and **Reset_In** inputs must be connected to input devices that act as Stop (e.g. E-STOP) and Reset (e.g. SWITCH), respectively.
- 4) the **In** input can be connected freely in the diagram (e.g. input function blocks or results of logical combinations).
- 5) **Output** can be connected freely in the diagram. **Output** is 1 (TRUE) when the IN input is 1 (TRUE) and the function block has been restarted.

Parameters

Enable Reset Network: when selected allows the distribution network to reset the function block. If not enabled, the function block can only be reset via the local **Reset_In** input.

Enable error out: if selected, it enables the **Error_Out** output that can be used to signal, with a logic 1 (TRUE), the presence of a failure.

Global Reset Enable: if selected, the operator can restart the entire system with the reset button from any node in the network. If deselected the operator can restart all the nodes **that have been not caused the stop** from anywhere in the network, except the node that has caused the stop (this node has to be restarted with its own reset).

Stop cause: if selected, it enables the **Network_stop** and **Local_stop** outputs and indicates the cause of the STOP status. These outputs are normally at 0 with the system in RUN and the Output at 1 (TRUE). If a network stop is requested, the Network_stop output increases to 1 (TRUE). If the Output output goes to 0 due to the In input or the Stop_in input, the Local_stop output goes to 1 (TRUE). The outputs will remain in this status until the next main reset.

The RESET command must be installed outside the zone of operation in a position where the zone of operation and the entire work area concerned are clearly visible.

The maximum number of MZERO modules that can be connected in network configuration is equal to 10.

Condition 1:

With reference to the Figure 42 and Figure 43, at power-on:

1. The Net_out of the various nodes are in the 0 (FALSE) condition;
2. The STOP signal is sent via the Net_out line;
3. When the RESET command is pressed on one of the nodes all the nodes that are present are started when the START signal is sent;
4. As the end result, the Net_out of all the connected nodes is in condition 1 (TRUE) if the various Net_in inputs are in condition 1 (TRUE);
5. The RUN signal is sent via the network of the 4 nodes present.

Condition 2:

With reference to the Figure 42 and Figure 43, when the emergency stop is pressed in one of the four nodes:

1. The Net_out moves to condition 0 (FALSE);
2. The STOP signal is sent via the Net_out line;
3. The next node receives the stop code and deactivates the output;
4. The stop command generates the stop code for all Net_in and Net_out lines;
5. As the end result, the Net_out of all the connected nodes is in condition 0 (FALSE).
6. When the emergency stop is restored to the normal position, all the nodes can be restarted by sending the START signal with a single reset. The latter condition does not occur when ENABLE RESET NETWORK is not enabled. In that case, the local reset method must be used. The system will employ about 4s to restore all the outputs of the blocks that make up the network.

➔ Perform a local reset of the module which caused the network shutdown, to restore its safety output.

Response Time

The max response time of the network starting from emergency stop is given by the formula:

$$MZero t_r = 22 ms + [186ms \times (number\ of\ controllers - 1)]$$

Emergency Stop Pressing	MZERO n°1	MZERO n°2	MZERO n°3	MZERO n°4
	$t_{rMZERO1}$	$t_{rMZERO2}$	$t_{rMZERO3}$	$t_{rMZERO4}$
MZERO	22 ms	208 ms	394 ms	580 ms

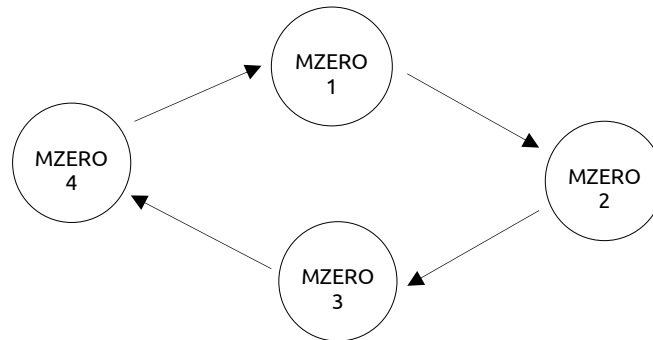

Condition 3:

With reference to the Figure 40 and Figure 41, when the IN input of the NETWORK function block of one of the 4 nodes moves to condition 0 (FALSE):

1. The local OUTPUT moves to condition 0 (FALSE);
2. The RUN signal continues to be sent via the Network_out lines;
3. The states of the remaining nodes remain unchanged;
4. In that case, local reset must be used. The Reset-in LED flashes to indicate this condition. This condition is signaled by the corresponding LED flashing Reset_In entrance. The affected node will be restarted with its own reset (if 'Reset Global Reset' is not selected).

The **Network_in** input and the **Network_out** output can only be mapped to the I/O pins of the MZERO.

MZERO signals with Network operative

NETWORK FUNCTIONAL BLOCK SIGNALS						
		Network in		Network out (OSSD)	Network out (STATUS)	Reset in
LED	FAIL EXT	IN (1)		OSSD (2)	STATUS	IN (3)
STATUS	STOP	OFF	OFF	RED	OFF	OFF
	CLEAR	OFF	BLINKING	RED/GREEN (BLINKING)	BLINKING	BLINKING
	RUN	OFF	ON	GREEN	ON	ON
	FAIL	ON	BLINKING	-	-	-

(1) Corresponding to the input where is wired Network IN
 (2) Corresponding to the input where is wired Network OUT
 (3) Corresponding to the input where is wired Reset IN

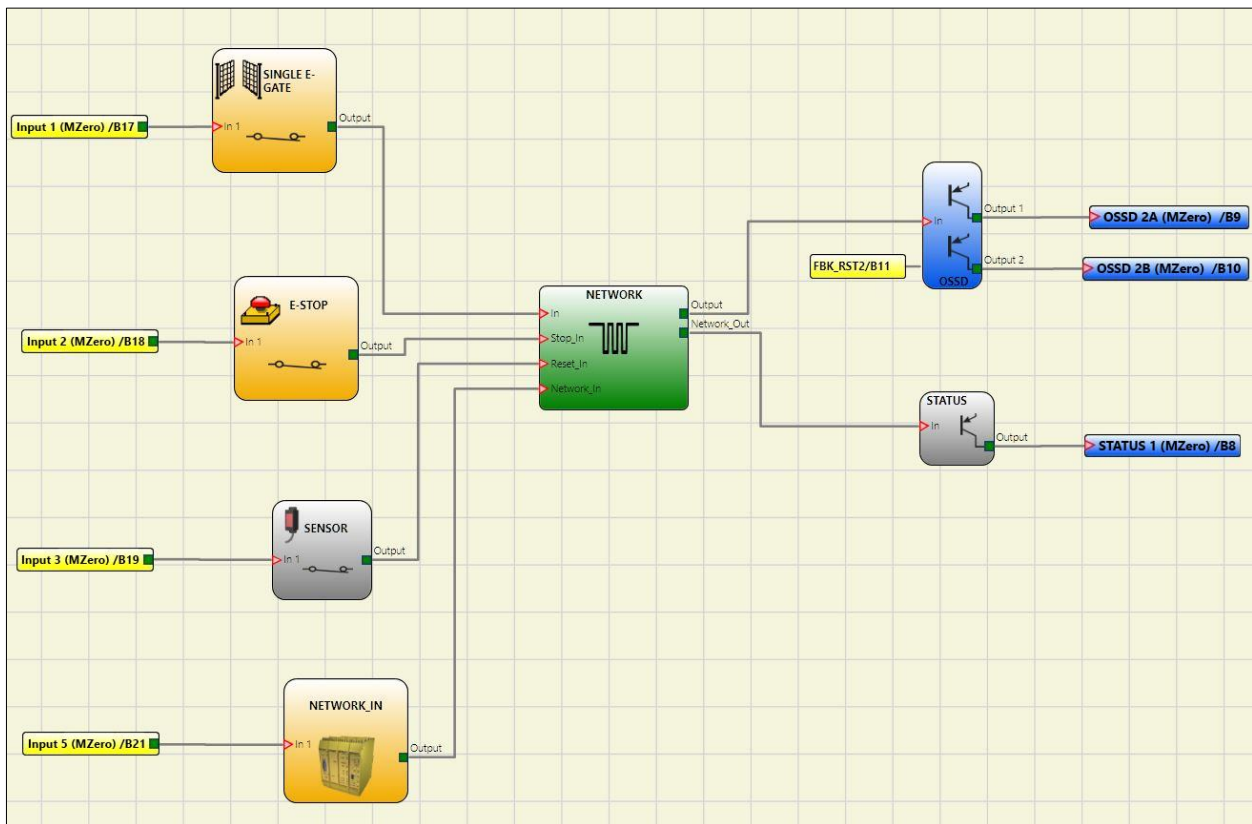

Figure 40 - NETWORK function block scheme example (Category 2)

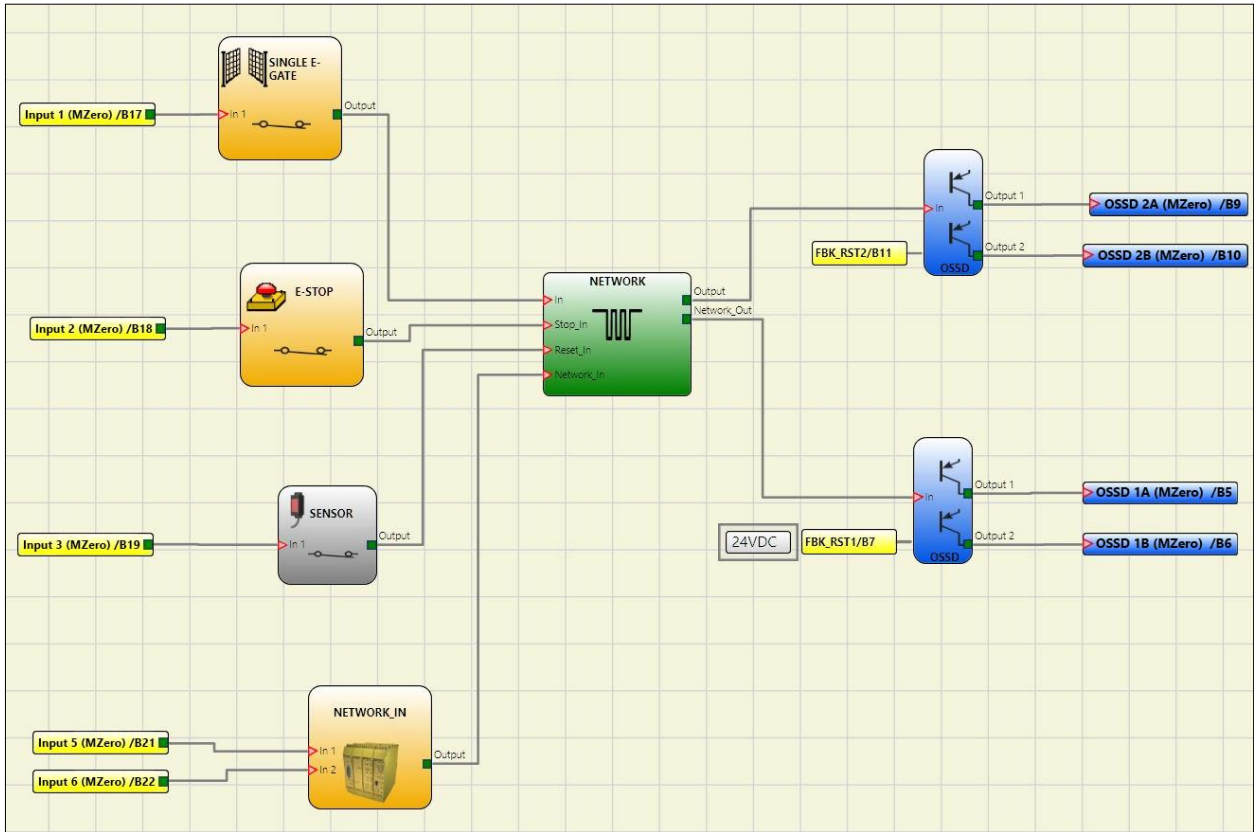
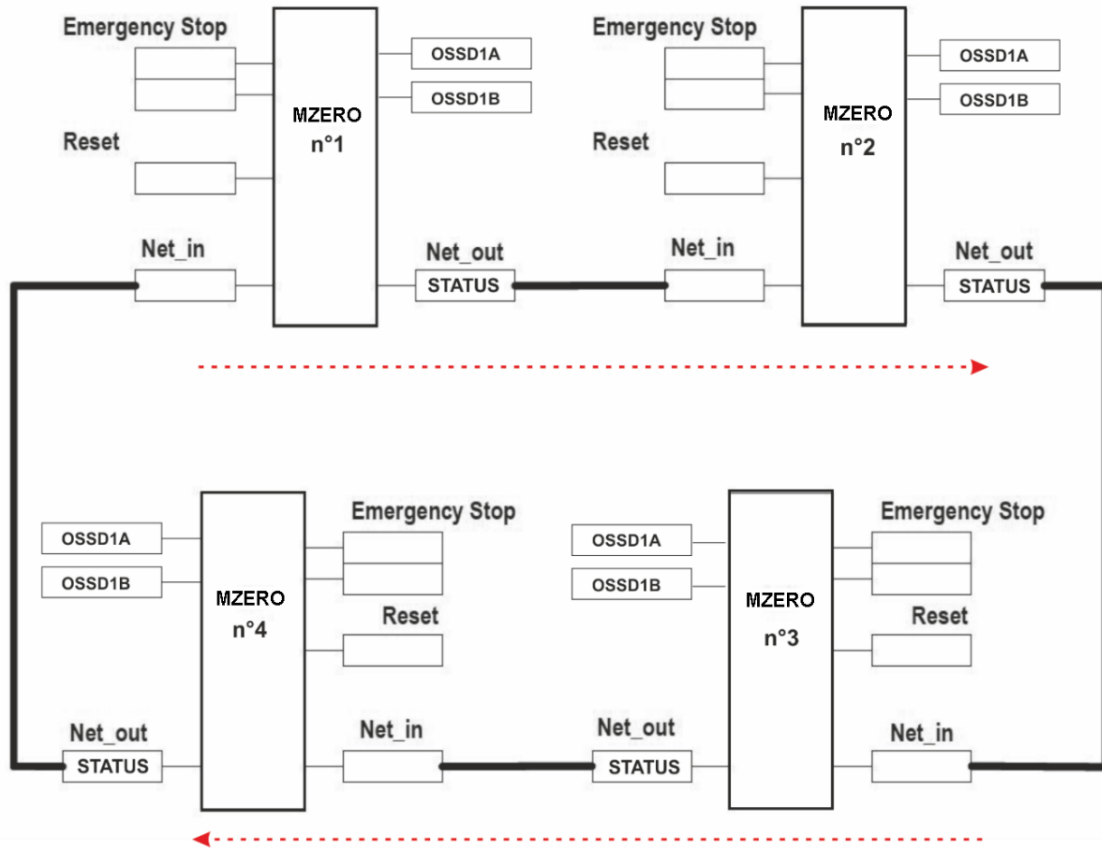

Figure 41 - NETWORK function block scheme example (Category 4)

Example of application in Category 2 according to ISO 13849-1:



Network data flow

Figure 42

Network parameters for the PL calculation

Architecture:	Cat.2
Diagnostic coverage:	DC = 90%
Reliability of Module MZERO:	MTTF _d = 154,51 (years)

Logical block diagram of a safety function using the network

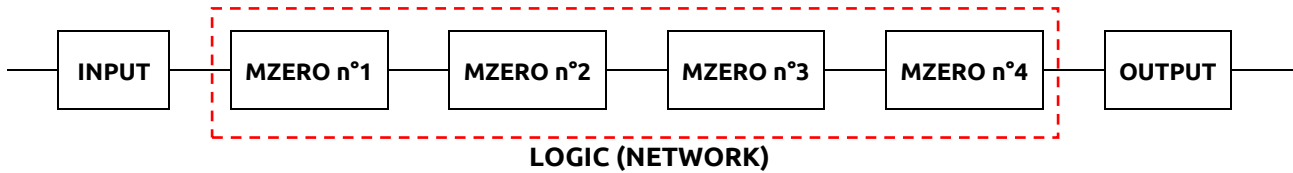

Example of application in Category 4 according to ISO 13849-1:

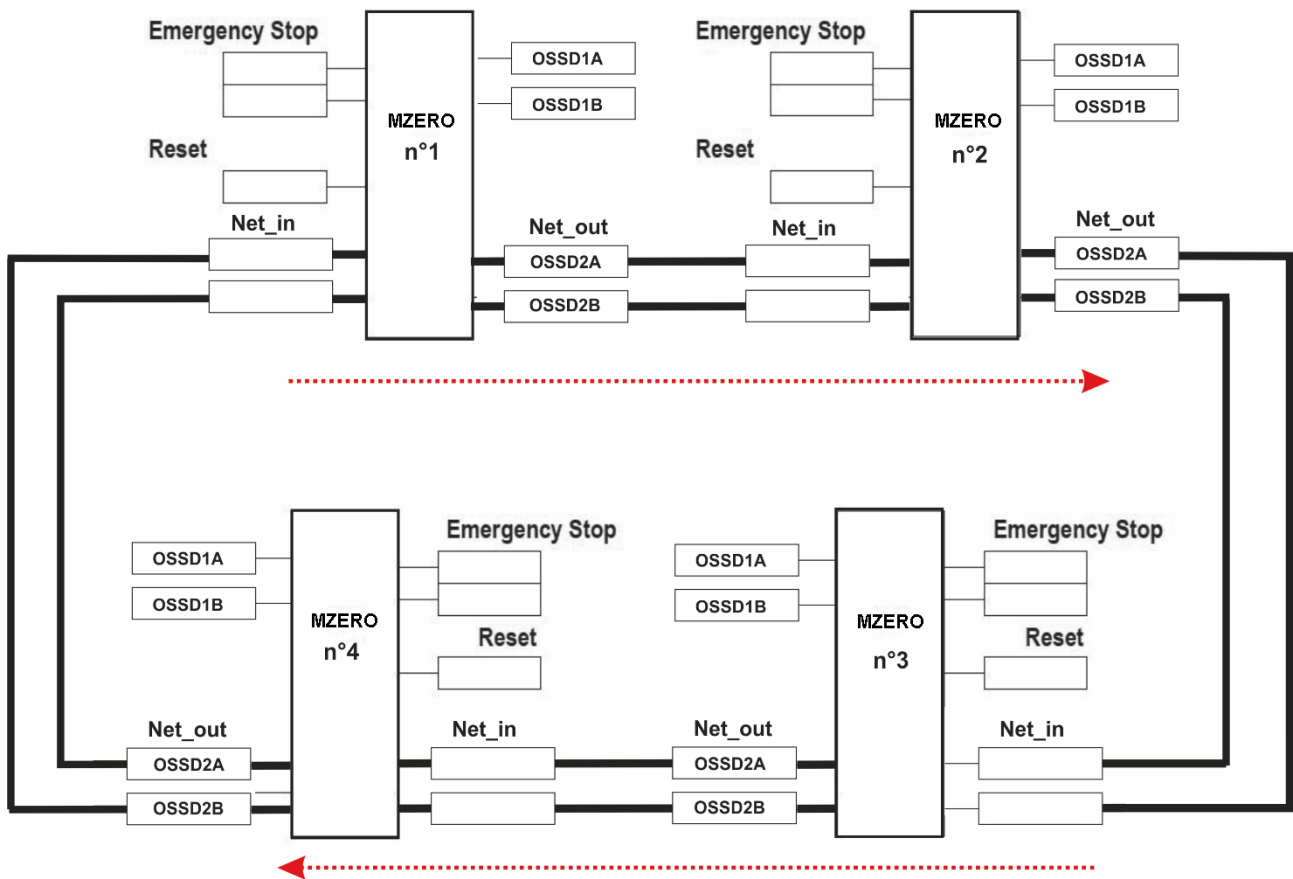

Network data flow

Figure 43

Network parameters for the PL calculation

Architecture:	Cat.4
Diagnostic coverage:	DC = 99%
PFH Module MZERO:	PFH _d = 1,53E-8 (hour ⁻¹)

Logical block diagram of a safety function using the network

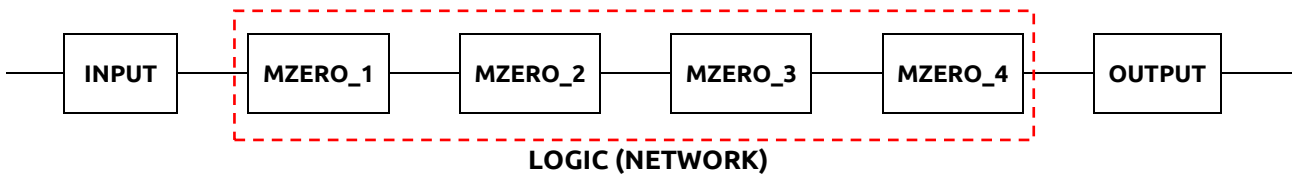

RESET

This operator generates a system Reset when there is a double OFF-ON-OFF transition on the corresponding input which lasts less than 5 s.

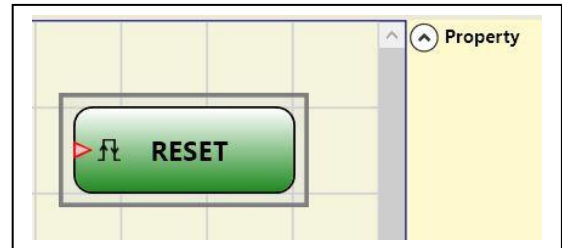
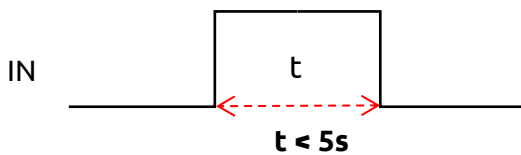

- ➔ If > 5s, RESET is not generated.
- ➔ It can be used to reset faults without disconnecting system power.

OSSD EDM (max number = 32)

The **OSSD EDM** (External Device Monitoring) operator allows to control an EDM feedback related to a safety output using a generic MZERO input.

The **Output** can only be connected to one safety output functional block (OSSD).

This output functional block must have the K external time monitor deactivated.

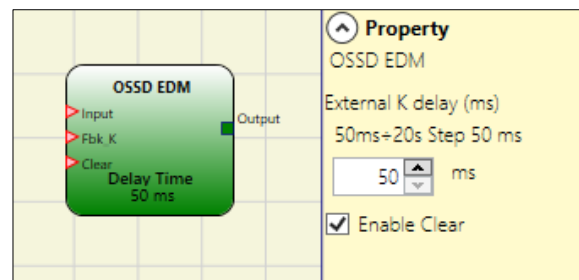

- OSSD output connected downstream is at high level (TRUE) -> the *Fbk_K* signal must be at low level (FALSE) (within the set delay) and vice versa.
- If the delay is not respected, the *Output* of the OSSD EDM block goes to low level (FALSE) and the anomaly is signaled by the flashing of the CLEAR led corresponding to the OSSD in error.

If *Enable Error Out* of the connected output is selected, this output is set to high level (TRUE) when an external FBK error is detected (example: exceeded the external time K).

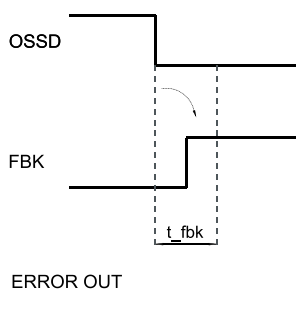

**Example of OSSD with correct Fbk signal:
In this case ERROR OUT=FALSE**

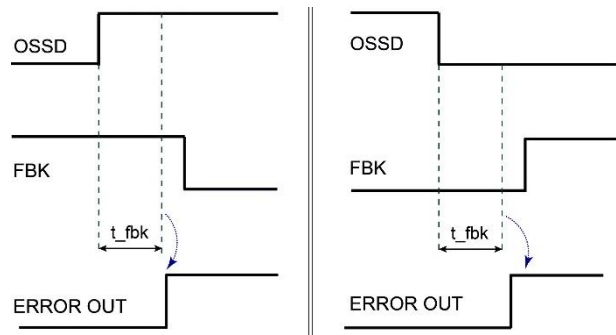

**Example of OSSD with incorrect Fbk signal
(External K delay exceeded):
In this case ERROR OUT=TRUE**

Parameters

External K delay: allows the operator to set the time window within which the external feedback signal (Fbk_K) is to be monitored (according to output conditions).

Enable Clear: if checked enables input Clear.

With this input at 1 it is possible to clear the error when the fault has been repaired. Using this input it is no longer necessary to reset MZERO or turn off the system.

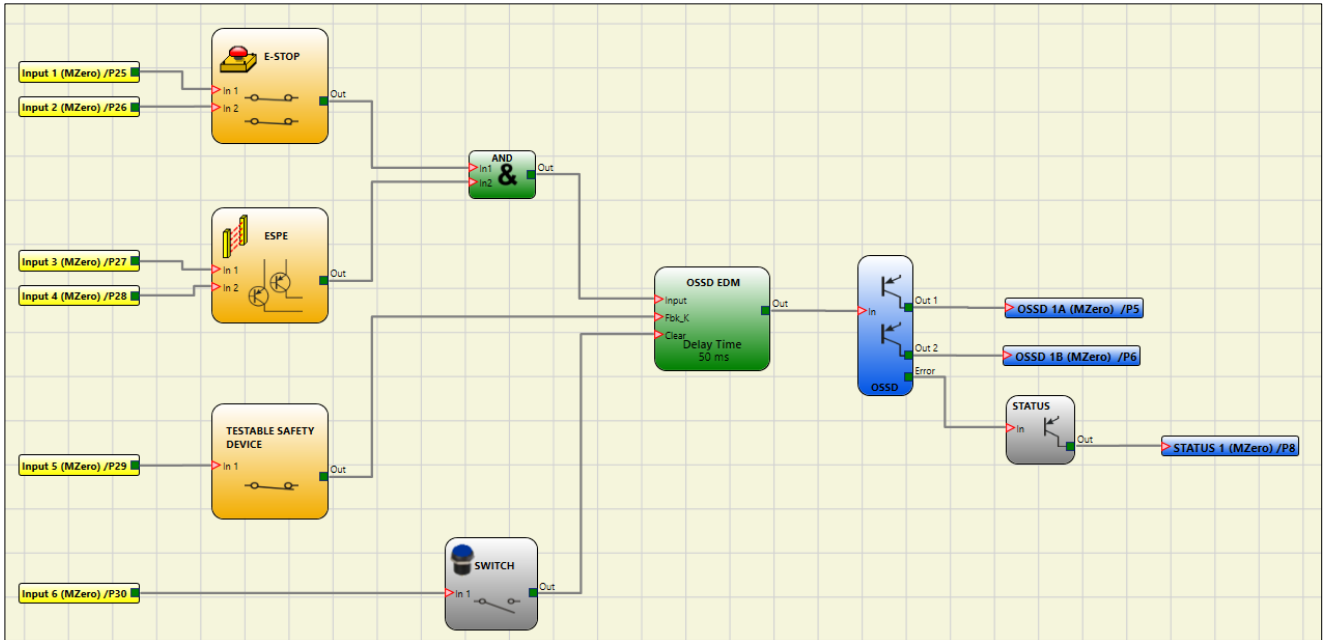
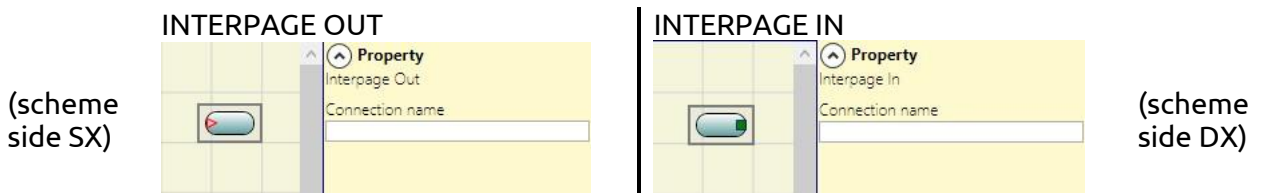

Figure 44 – OSSD EDM operator scheme example

INTERPAGE IN/OUT

If the scheme is very complicated and requires a connection between two elements very far, use the "Interpage" component.



The element "Interpage out" must have a name which, invoked by the corresponding "Interpage in", allows the desired link.

INTFBK_IN / INTFBK_OUT (max number = 8)

This operator can be used to create logical loops or to connect the output of a function block to the input of another function block. **IntFbk** consist of *IntFbk_In* and *IntFbk_Out*; after one MZERO logical cycle delay, every *IntFbk_In* assumes the same logical value of the corresponding *IntFbk_Out*.

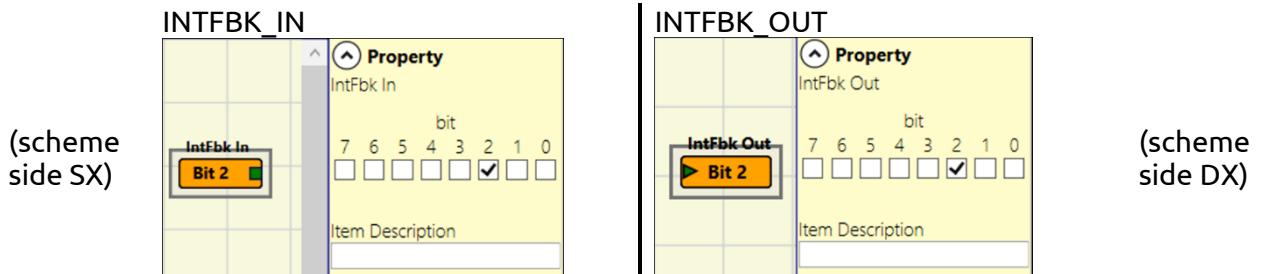

The element "*IntFbk_Out*" must have a number which, invoked by the corresponding "*IntFbk_In*", allows the desired link.

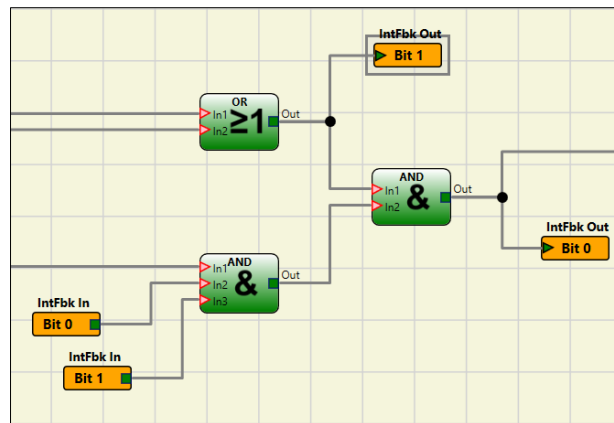

Figure 45 – INTFBK_IN / INTFBK_OUT operator scheme example

If not carefully designed feedback loops could trigger dangerous system oscillations and as a consequence makes the system unstable. An unstable system may have severe consequence to the user like severe injuries or death.

SPECIAL APPLICATIONS

Output delay with manual

If the operator needs to have two OSSD output with one of them delayed (in MANUAL mode) use the following scheme:

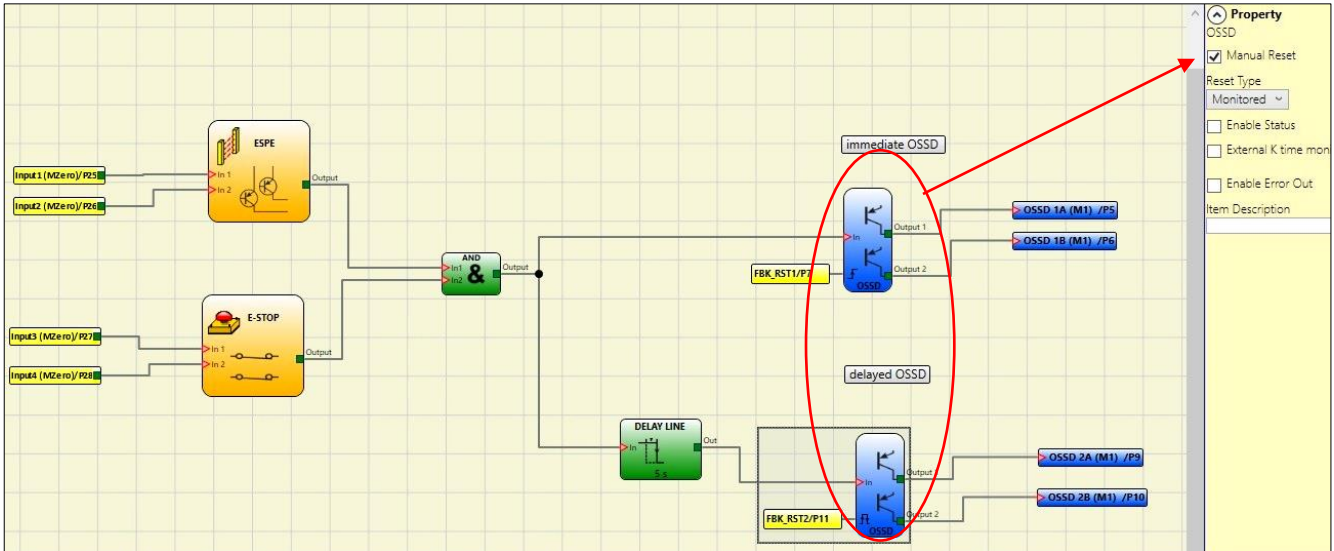

Figure 46 - Two outputs with one delayed (in MANUAL mode)

SIMULATOR FEATURE

- This simulator is only designed to assist in the design of safety functions.
- The results of the simulation do not constitute validation of the project.
- The resulting safety function must always be validated, from the point of view of both hardware and software, under actual usage conditions in accordance with the applicable regulations, such as ISO/EN 13849-2: validation or IEC/EN 62061: Chapter 8 - Validation of the safety-related electrical control system.
- MZERO configuration safety parameters are provided in the MZD software report.
- Simulator feature is available only if MZERO controller is disconnected from the PC.

The top toolbar features two new green icons:

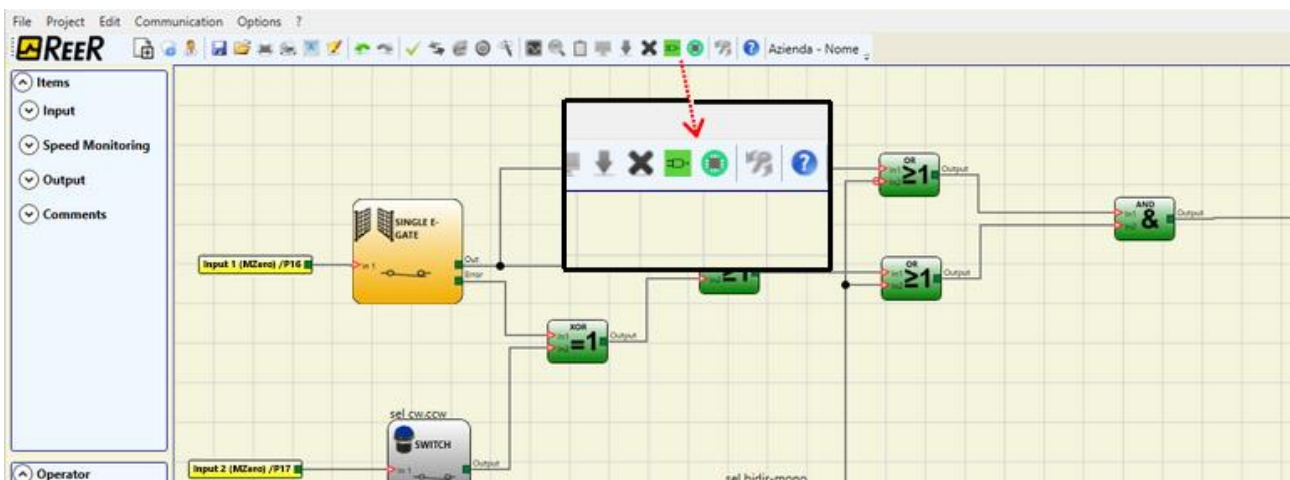

Figure 47 – Simulator icons

These icons refer to the new Simulator function.

- The first icon indicates "Schematic Simulation". It enables the schematic simulator (both static and dynamic) in which you can activate the input to verify the diagram that is loaded.
- The second icon indicates "Graphic Simulation". It enables the simulator guided by the stimuli file which also allows the desired traces to be displayed in a specific graph.

Schematic Simulation

Click on the  icon to start the schematic simulation.

Schematic simulation can be used to check/guide the output signals of the various function blocks in real-time, even during the actual simulation. You may choose the block outputs you wish to control and check the response of the various elements of the schematic model according to the colors of the different lines.

As with the monitor function, the color of the line (or of the actual key) indicates the signal status: green means the signal is set to LL1, red means the signal is set to LL0.

With "Schematic Simulation", some new keys appear in the toolbar. These can be used to control the simulation: the "Play" and "Stop" keys to start and stop the simulation, the "PlayStep" key for step-by-step operation and the "Reset" key. When the simulation is reset, the Time value is reset to 0 ms.

When you press "Play" to start the simulation, the amount of time that has elapsed is displayed next to the word "Time". This time is measured in "Step" units of time multiplied by the user-defined "KT" factor.

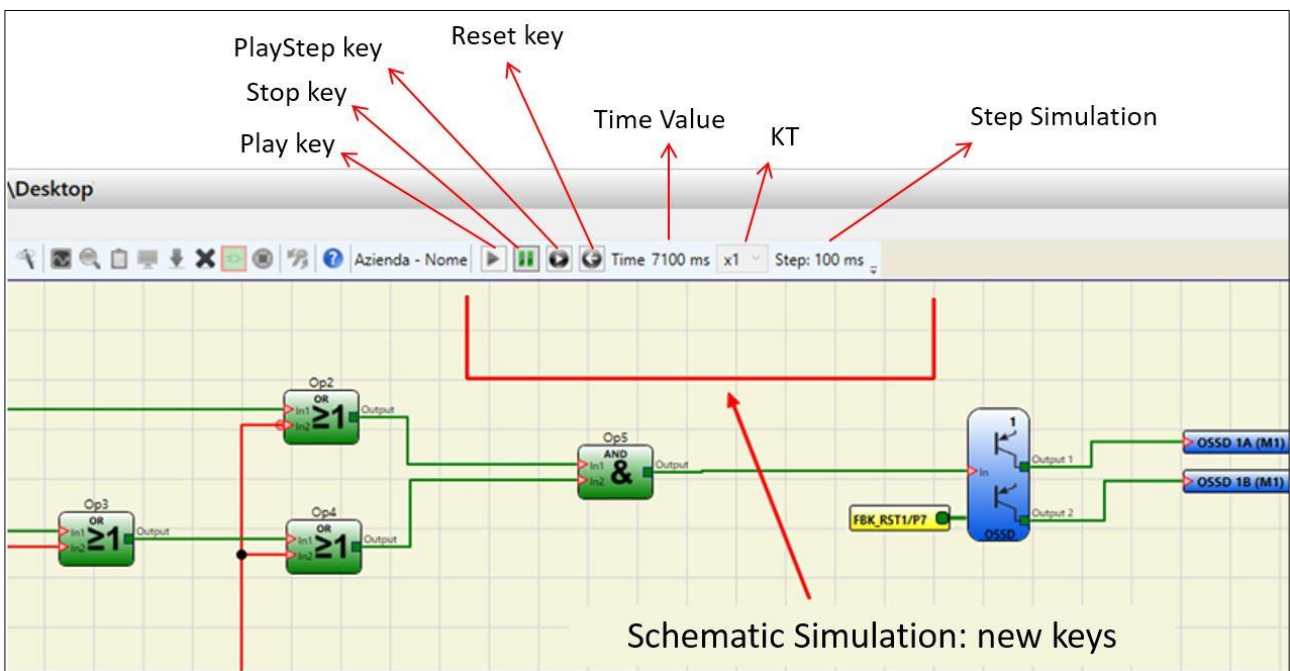
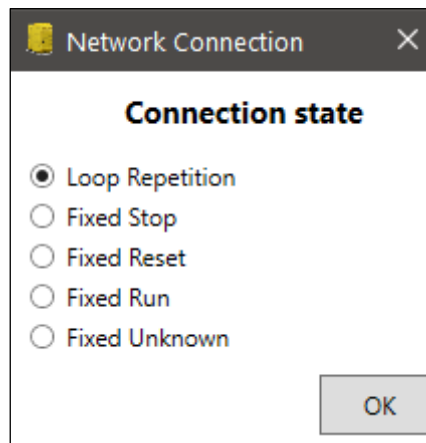
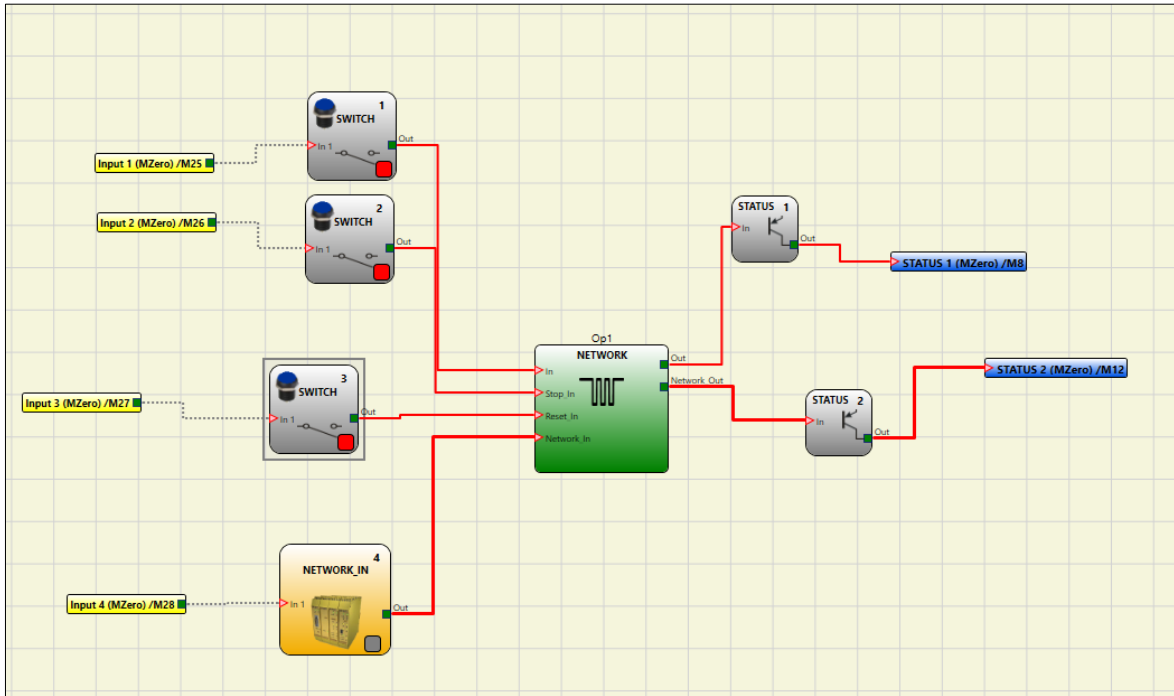

Figure 48 – Schematic Simulation

Click on the bottom right key of each input block to activate the respective output status (even when the simulator is not running, i.e. when the time is not elapsing: in this case the simulation is "static"). If the key turns red when you click on it, the output will be set to level LL0. If it turns green, the output will be set to level LL1.

In the Network in operator the key is grey. This indicates that the value must be entered manually in a specific pop-up window.



➔ The keys for enabling block outputs are shown at the top, an example of a pop-up window for entering, the connection state.

How to use graphic simulation

Click on the  icon to start the graphic simulation.

Graphic simulation can be used to display the signal pattern over time in a graph. First you must define the stimuli in a specific text file: this means defining the trend over time in the waveforms used as inputs (stimuli). Based on the stimuli file created, the simulator injects these into the diagram and displays the traces required in order to perform the simulation.

When the simulation is complete, a graph like the one shown below is automatically displayed. From the graph you can print the traces displayed ("Print"), save the results in order to load them again later (Save) or display other traces ("Change visibility").

The names of the traces match the description of the function blocks.

Click the "X" key (top right) to exit the graphic simulation environment.

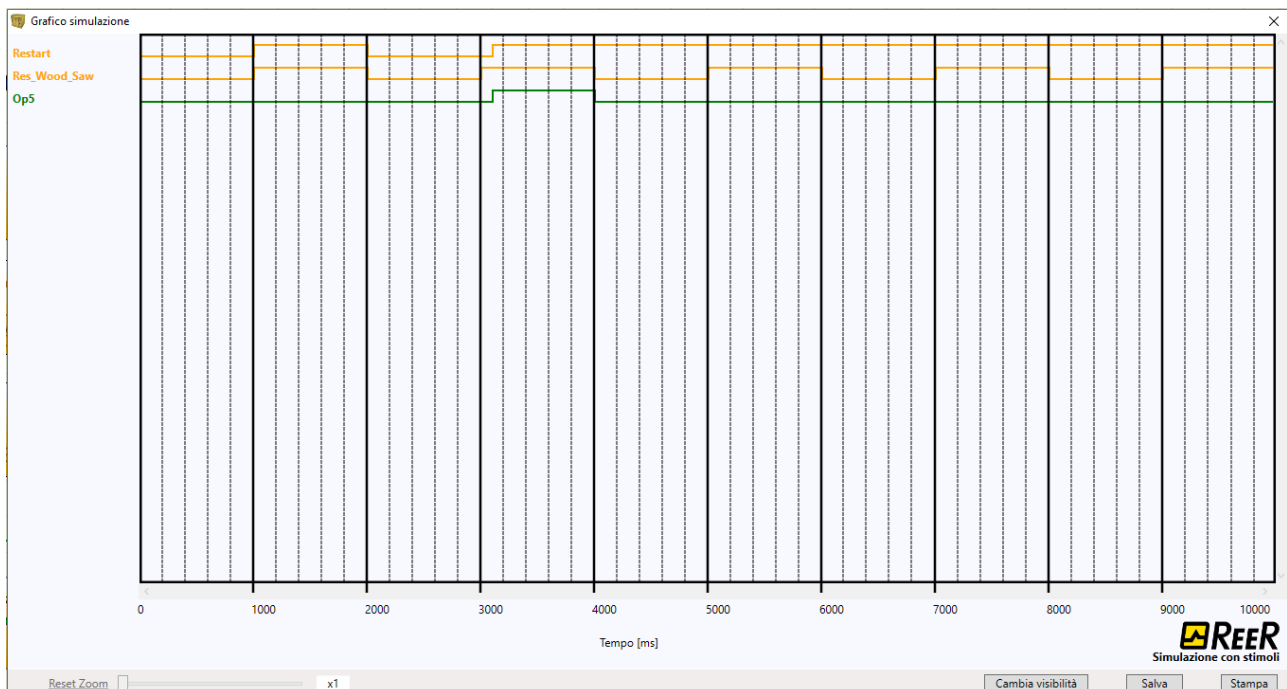

Figure 49 – Example of a result of the graphic simulation.

➔ It shows the traces and the three keys in the bottom right corner for selecting the traces, saving and printing.

The simulation can only be carried out after performing at least the following steps.

1. Create a stimuli file to suit your needs.
2. Upload the stimuli file and wait until the simulation finishes.

Click on the icon to display the page shown below.

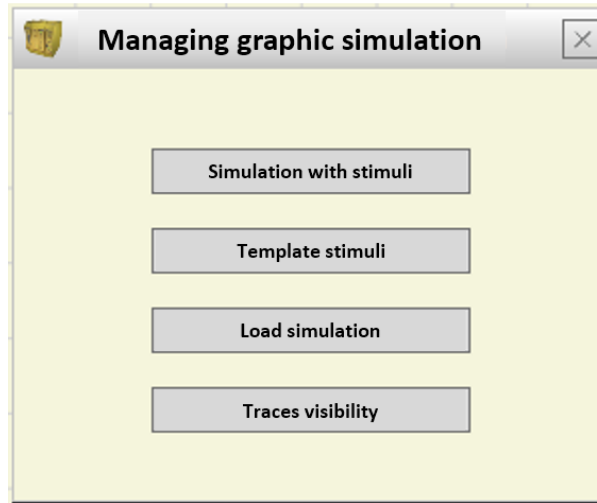

Figure 50 – Menu for selecting the graphic simulation mode

The functions of each key in the menu shown in Figure 50 will now be described:

Template Stimuli: used to save the template file with the desired name and disk location. This file will contain the names of the signals as shown in Figure 51 and Figure 52. You may use a text editor to enter the status of the input signals at a certain time as well as the duration of the simulation and the time step to be used.

```

esempio.sti - Blocco note
File Modifica Formato Visualizza ?
// Stimulus Template
//Sim 0:EndTime:Step (time unit ms)
Sim 0:10000:100

// Switch
Input1
0:0
Time1:1
Time2:0

// Switch
Input2
0:0
Time1:1
Time2:0

// OSSD
Fbk_rst1
0:0
Time1:1
Time2:0
    
```

Figure 51 – Template file immediately after saving

```

esempio.sti - Blocco note
File Modifica Formato Visualizza ?
// Stimulus Template
//Sim 0:EndTime:Step (time unit ms)
Sim 0:10000:100

// Switch
Input1
0:0
800:1
2000:0
2500:1
2900:0

// Switch
Input2
0:0
1800:1
2300:0
2900:1
3900:0

// OSSD
Fbk_rst1
0:1
    
```

Figure 52 –Example of complete template file

Simulation with Stimuli: used to load a template file (suitably completed) and, once loaded, to immediately start the simulation.

At the end of the simulation, a graph is displayed with the resulting signals.

Load simulation: used to load a previously completed simulation provided at least one has been saved.

Traces visibility: used to select the traces (signal waveforms) to be displayed in the graph. When you press this key, it opens a pop-up window as shown in Figure 53 from which you can add or remove traces to or from the graph.

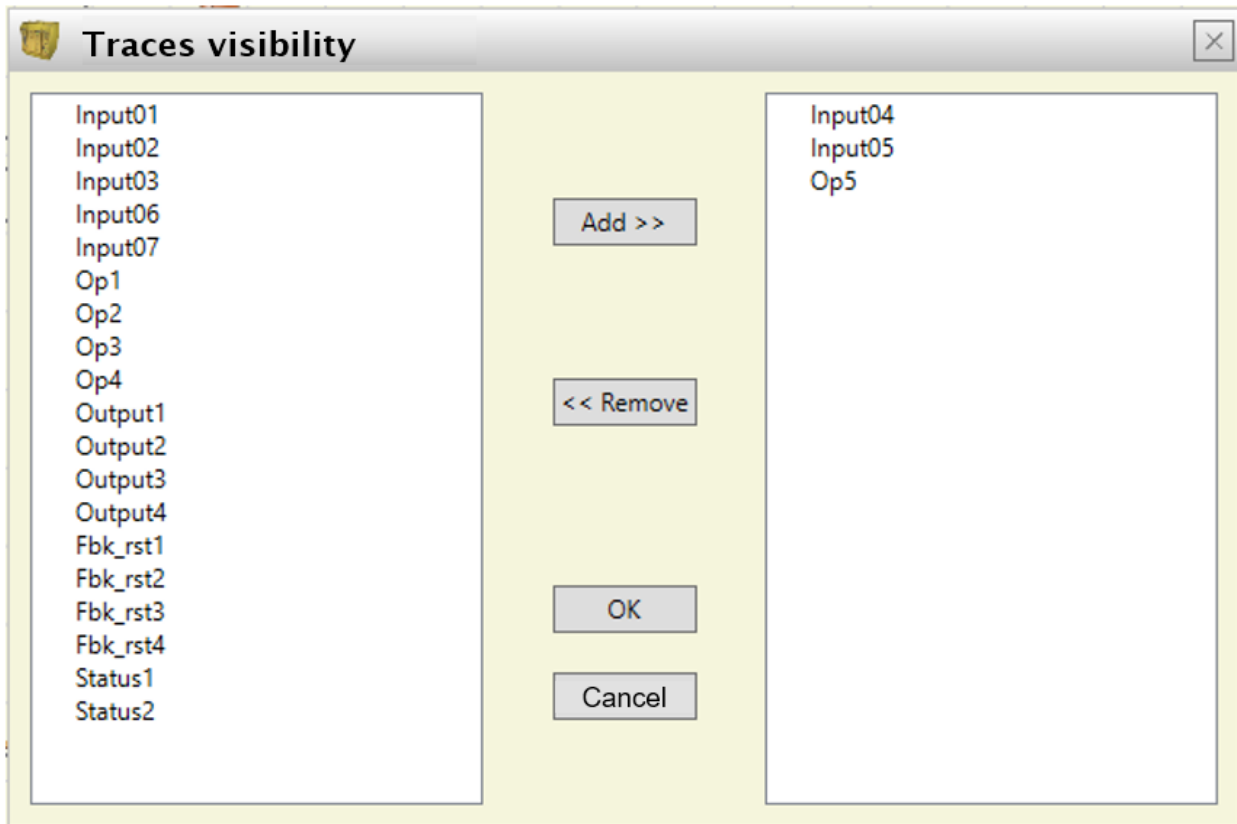

Figure 53 - Traces visibility.

➔ The traces that can be added to the graph are shown in the box on the left. The traces currently displayed and which can be removed from the graph are shown in the box on the right.

MZERO FAIL CODES

In case of malfunction the MZERO system transmits to the MZD software a code corresponding to the error detected by the MZERO.

To read the code, proceed as follows:

connect the MZERO (indicating FAIL by led) to the PC using the USB cable;

- launch the software MZD;
- use the icon  for the connection; a window appears to request the password; enter the password; a window appears with the error code occurred.

The following table lists all possible errors detected and their solution.

CODE	FAIL	SOLUTION
19D, 20D	<i>The two MZERO microcontrollers do not see the same hw/sw configuration</i>	CHECK CONNECTIONS
130D 135D 137D 138D 140D 194D 197D 198D 199D 201D 202D 203D 205D	<i>Errors solid state output OSSD1</i>	CHECK THE OSSD1 CONNECTIONS
144D 149D 151D 152D 154D 208D 211D 212D 213D 215D 216D 217D 219D	<i>Errors solid state output OSSD2</i>	CHECK THE OSSD2 CONNECTIONS
158D 163D 165D 166D 168D 222D 225D 226D 227D 229D 230D 232D 233D	<i>Errors solid state output OSSD3</i>	CHECK THE OSSD3 CONNECTIONS
172D 177D 179D 180D 182D 236D 239D 240D 241D 243D 244D 245D 247D	<i>Errors solid state output OSSD4</i>	CHECK THE OSSD4 CONNECTIONS
All other codes are related to errors or an internal malfunction. Please replace MZERO that gave the error or return to Reer for repair and/or debugging and inform REER at the time of shipment.		

The following table lists all internal errors.

CODE	FAIL	SOLUTION
1D...31D	<i>Microcontroller Error</i>	TRY TO RESTART SYSTEM. IF ERROR PERSISTS, SEND UNIT TO REER LABORATORY FOR REPAIR.
32D...63D	<i>Mainboard Error</i>	
128D...143D 192D...205D	<i>OSSD1 Error</i>	TRY TO RESTART SYSTEM. IF ERROR PERSISTS, SEND UNIT TO REER LABORATORY FOR REPAIR.
144D...159D 206D...219D	<i>OSSD2 Error</i>	
160D...173D 220D...233D	<i>OSSD3 Error</i>	
174D...188D 234D...247D	<i>OSSD4 Error</i>	

ERRORS LOG DOWNLOAD

The errors log file can be visualized using the icon  in the standard tool bar.
(Password Required: level 1).

A table will appear with the last 5 errors occurred from the date when the schema was sent to MZERO or from the date of error log cancellation (icon .

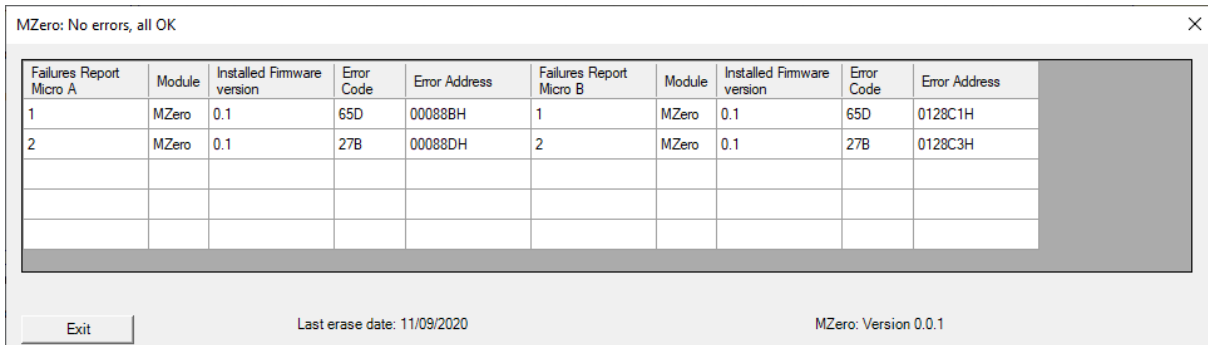

Failures Report Micro A	Module	Installed Firmware version	Error Code	Error Address	Failures Report Micro B	Module	Installed Firmware version	Error Code	Error Address
1	MZero	0.1	65D	00088BH	1	MZero	0.1	65D	0128C1H
2	MZero	0.1	27B	00088DH	2	MZero	0.1	27B	0128C3H

Exit Last erase date: 11/09/2020 MZero: Version 0.0.1

Figure 54 – MZERO Errors Log Table

ACCESSORIES AND SPARE PARTS

MODEL	DESCRIPTION	CODE
MZERO	Stand Alone Programmable Safety controller (16 inputs / 4 double OSSD)	1100005
MR2	Safety relay unit (2 relays)	1100040
MR4	Safety relay unit (4 relays)	1100041
MR8	Safety relay unit (8 relays)	1100049
CSU	USB cable for connection to PC	1100062

WARRANTY

ReeR warrants that all of its MZERO units shall be free from defects in material or workmanship for a period of 12 (twelve) months from the date of shipment. This warranty applies to the products under normal conditions of use.

If the product proves to be defective during the warranty period, ReeR will repair or replace any faulty parts without any charge for material or labour.

ReeR S.p.A. may, at its discretion, replace the defective equipment with the same type of equipment or with equipment having the same characteristics, rather than repair it.

This warranty is subject to the conditions listed below:

The customer must inform ReeR of the fault within twelve months from the date of delivery of the product.

The equipment and all components must be in the condition as they were at the time of delivery by ReeR.

The fault or defect must not be caused either directly or indirectly by:

- Improper use;
- Failure to comply with the instructions for use;
- Carelessness, misuse, incorrect maintenance;
- Repairs, modifications, adaptations not performed by ReeR, tampering, etc.;
- Accidents or collisions (also during transportation and as a result of force majeure);
- Other causes for which ReeR cannot be held liable.

The defective equipment must be delivered or shipped to ReeR's works to be repaired: the warranty does not cover costs of transport or the risk of damage to or loss of the equipment during shipment, which shall be borne by the customer.

All products and components that are replaced become the property of ReeR.

ReeR shall not be held liable under any other warranties or rights except for those expressly indicated above. ReeR shall not therefore accept claims to pay damages for expenses, interruption of work or other factors or circumstances in any way related to failure of the product or any parts thereof.

Please, visit the website www.reersafety.com for the list of the authorised representative of each Country.



Precise, complete compliance with all standards, instructions and warnings in this handbook is essential for the correct operation of the device. ReeR therefore declines any responsibility for all and anything resulting from failure to comply with all or some of the aforesaid instructions.

Characteristics are subject to change without prior notice. No part of this document may be reproduced unless authorised by ReeR.

CE DECLARATION OF CONFORMITY



Dichiarazione CE di conformità / EC declaration of conformity

Torino, 26/09/2022

 REER SpA - via Carcano 32
 10153 - Torino - Italy

dichiara che il **Controllore I/O Programmabile MZERO** è un dispositivo di sicurezza realizzato in conformità alle seguenti Direttive Europee:
 declares that the **MZERO Stand Alone Programmable Safety I/O Controller** is a safety device complying with the following European Directives:

2006/42/EC	"Direttiva Macchine" "Machine Directive"
2014/30/EU	"Direttiva Compatibilità Elettromagnetica" "Electromagnetic Compatibility Directive"
2014/35/EU	"Direttiva Bassa Tensione" "Low Voltage Directive"
2011/65/EU	"Limitazioni sull'uso di sostanze pericolose nelle Apparecchiature Elettriche ed Elettroniche" "Restriction of the use of certain hazardous substances in Electrical and Electronic Equipment"

ed è conforme alle seguenti norme:
 and complies with the following standards:

EN 61131-2 (2007)	Controllori programmabili - Parte 2: Specifiche e prove delle apparecchiature. Programmable controllers - Part 2. Equipment requirements and tests.
EN ISO 13849-1 (2015)	Sicurezza del macchinario: Parti dei sistemi di comando legate alla sicurezza. Parte 1: Principi generali per la progettazione. Safety of machinery: Safety-related parts of control systems - Part 1: General principles for design.
EN 61496-1 (2020)	Sicurezza del macchinario: Dispositivi Elettrosensibili di protezione, Parte 1: Requisiti generali e tests. Safety of machinery: Electro sensitive protective equipment, Part 1: General requirements and tests.
EN 61508-1 (2010)	Sicurezza funzionale di impianti elettrici/elettronici/programmabili legati alla sicurezza: Requisiti generali. Functional safety of electrical/electronic programmable electronic safety related systems: General requirements.
EN 61508-2 (2010)	Sicurezza funzionale di impianti elettrici/elettronici/programmabili legati alla sicurezza: Requisiti per impianti elettrici/elettronici/programmabili legati alla sicurezza. Functional safety of electrical/electronic/programmable electronic safety related systems: Requirements for electrical/electronic/programmable electronic safety-related systems.
EN 61508-3 (2010)	Sicurezza funzionale di impianti elettrici/elettronici/programmabili legati alla sicurezza: Requisiti Software. Functional safety of electrical/electronic programmable electronic safety related systems: Software requirements.
EN 61508-4 (2010)	Sicurezza funzionale di impianti elettrici/elettronici/programmabili legati alla sicurezza: Definizioni e abbreviazioni. Functional safety of electrical/electronic/programmable electronic safety related systems: Definitions and abbreviations.
IEC 61784-3 (2008)	Reti di comunicazione industriali - Profili - Parte 3: Sicurezza funzionale dei bus di campo - Norme generali e profilo definizioni. Industrial communication networks - Profiles - Part 3: Functional safety fieldbuses - General rules and profile definitions.
EN 62061 (2021)	Sicurezza del macchinario. Sicurezza funzionale dei sistemi di comando e controllo elettrici, elettronici e programmabili correlati alla sicurezza. Safety of machinery - Functional safety of safety-related electrical, electronic and programmable electronic control systems.
EN 81-20 (2020)	Regole di sicurezza per la costruzione e l'installazione di Ascensori. Ascensori per il trasporto di persone e cose. Parte 20: Ascensori per persone e cose accompagnate da persone. Safety rules for the construction and installation of lifts. Lifts for the transport of persons and goods. Passenger and goods passenger lifts.
EN 81-50 (2020)	Regole di sicurezza per la costruzione e l'installazione di Ascensori. Verifiche e prove. Parte 50: Regole di progettazione, calcoli, verifiche e prove dei componenti degli ascensori. Safety rules for the construction and installation of lifts. Examinations and tests. Design rules, calculations, examinations and tests of lift components

raggiungendo il livello di sicurezza pari a: **SIL 3 / SILCL 3 / PL e/ Cat. 4 / Tipo 4 (v. standard corrispondenti)**
 reaching a safety level corresponding to: **SIL 3 / SILCL 3 / PL e / Cat. 4 / Type 4 (see related standards)**

ed è identico all'esemplare esaminato ed approvato con esame di tipo CE da:
 and is identical to the specimen examined and approved with a CE - type approval by:

TÜV SÜD Product Service GmbH – Zertifizierstelle – Ridlerstraße 65 – 80339 – München – Germany
N.B. number: 0123 – Certificate No. Z10 024820 0077 Rev. 01

Responsabile per la documentazione tecnica:
 Responsible person for technical documentation:

Carlo Pautasso

Carlo Pautasso
 Direttore Tecnico
 Technical Director

Simone Scaravelli
 Amministratore Delegato
 Managing Director

UKCA DECLARATION OF CONFORMITY

ReeR declares that the stand alone programmable safety controller MZERO complies with following UK legislation:

- S.I. 2008 No. 1597 - The Supply of Machinery (Safety) Regulations
- S.I. 2016 No. 1101 - Electrical Equipment (Safety) Regulations
- S.I. 2016 No. 1091 - Electromagnetic Compatibility Regulations
- S.I. 2012 No. 3032 - The Restriction of the Use of Certain Hazardous Substances in Electrical and Electronic Equipment Regulations

➔ Please refer to the link <https://www.reersafety.com/certifications/> to download the complete UKCA Declaration of Conformity.



Via Carcano, 32
10153 Torino, Italy
T +39 011 248 2215
F +39 011 859 867
www.reersafety.com
info@reer.it