

**Installation Instructions for Shunt Trip for LDB, LD, HLD, LDC, LW, HLW, LWC
Circuit Breakers, Series C Molded Case Switches, and Motor Circuit Protectors (HMCP)**



WARNING

CONTACT WITH ENERGIZED EQUIPMENT CAN RESULT IN DEATH, SEVERE PERSONAL INJURY, OR SUBSTANTIAL PROPERTY DAMAGE. DO NOT ATTEMPT TO INSTALL OR PERFORM MAINTENANCE ON EQUIPMENT WHILE IT IS ENERGIZED. ALWAYS VERIFY THAT NO VOLTAGE IS PRESENT BEFORE PROCEEDING WITH THE TASK, AND ALWAYS FOLLOW GENERALLY ACCEPTED SAFETY PROCEDURES.

CUTLER-HAMMER IS NOT LIABLE FOR THE MISAPPLICATION OR MISINSTALLATION OF ITS PRODUCTS.

The user is cautioned to observe all recommendations, warnings, and cautions relating to the safety of personnel and equipment as well as all general and local health and safety laws, codes, and procedures.

The recommendations and information contained herein are based on Cutler-Hammer experience and judgement, but should not be considered to be all-inclusive or covering every application or circumstance which may arise. If any questions arise, contact Cutler-Hammer for further information or instructions.

1. INTRODUCTION

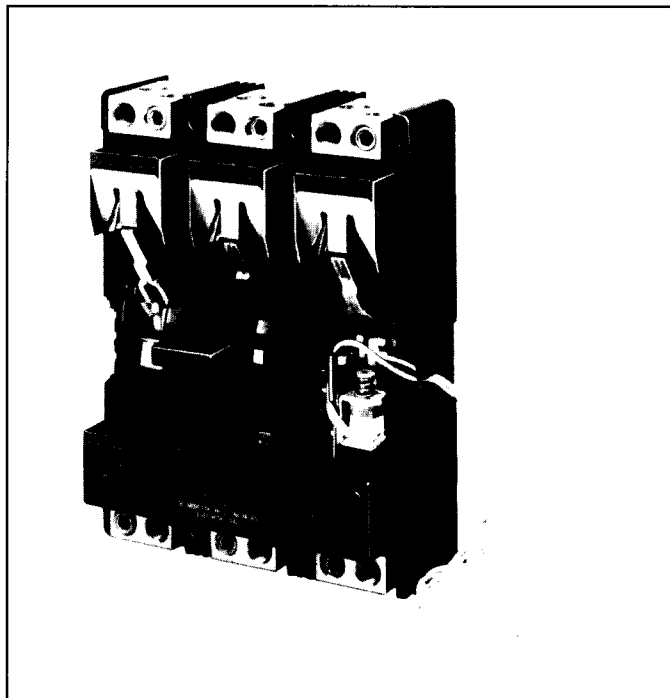

Fig. 1-1 Shunt Trip Installed in L-Frame Circuit Breaker

GENERAL INFORMATION

The shunt trip (Fig. 1-1) provides remote controlled electrical tripping for the circuit breaker. It consists of an intermittent rated solenoid with a tripping plunger and a cutoff switch attached to a plug-in module. The plug-in module is mounted in slots in the top of the trip unit and occupies the accessory cavity in the circuit breaker frame. When the solenoid is energized, the plunger extends and presses against an intermediate plunger which operates the trip bar in the trip unit. As the circuit breaker trips, the molded crossbar presses against the cutoff switch operating arm to open the cutoff switch, disconnecting power to the solenoid and preventing coil burn out.



WARNING

IF ENERGY IS APPLIED TO SHUNT TRIP LEADS, DO NOT ATTEMPT TO RESET AND CLOSE THE CIRCUIT BREAKER. ATTEMPTING TO CLOSE THE CIRCUIT BREAKER WHILE ENERGIZED WILL RESULT IN A "SHOCKOUT" CONDITION.

Table 1-1 lists application and electrical operating rating data for the shunt trip.

For this publication, the term circuit breaker shall also include molded case switch and motor circuit protector.

Depending on the model ordered, connections for the shunt trip are in one of four forms. The standard wiring configuration is pigtail leads exiting the rear of the base directly behind the shunt trip. Optional configurations include a terminal block mounted on the same side of the base as the accessory, leads exiting the side of the base where the accessory is mounted, and leads exiting the rear of the base on the side opposite the accessory. The 18-inch long pigtail leads are color coded for identification; identification labels are provided for pigtail leads and terminal block points. For allowable locations of all accessories, refer to Frame Book 29-104.

Note: When the walking beam interlock is used with the circuit breaker, the rear trough cannot be used for accessory pigtail leads.

This instruction leaflet (I.L.) gives detailed procedures for installing the shunt trip.

2. INSTALLATION

Note: The shunt trip can be field-installed in LD, HLD, and LDC circuit breakers under UL File E64983.

The shunt trip can be field-installed in LW, HLW, and LWC circuit breakers.

The shunt trip is listed for factory installation under UL File E7819.

For sealed circuit breakers (LDB), Underwriters Laboratories Inc. UL 489 requires that internal accessories be installed at the factory. The shunt trip is listed for factory installation under UL File E7819.

Where local codes and standards permit and UL listing is not required, internal accessories can be field installed in sealed circuit breakers. In this case, UL listing becomes invalid and the label should be removed.

Before attempting to install the shunt trip, check that the catalog number is correct as ordered and that the rating of the accessory satisfies job requirements.

The shunt trip, shown in kit form in Fig. 2-1, is installed in the right or left accessory mounting cavity of a 2-, 3-, or 4-pole circuit breaker with an LT (fixed thermal) or LTA (adjustable thermal) trip unit; and, in the left pole only of a circuit breaker with an LS (electronic) trip unit. A shunt trip must be installed in the circuit breaker before the circuit breaker is mounted in an electrical system. To install the shunt trip, perform the following procedures:

Note: A circuit breaker that is mounted in an electrical system must be removed to install the accessory. To ensure correct accessory installation, the circuit breaker must be placed on a horizontal surface.



WARNING

THE VOLTAGES IN ENERGIZED EQUIPMENT CAN CAUSE DEATH OR SEVERE PERSONAL INJURY. BEFORE REMOVING A CIRCUIT BREAKER INSTALLED IN AN ELECTRICAL SYSTEM, MAKE SURE THE CIRCUIT BREAKER IS SWITCHED TO THE OFF POSITION AND THERE IS NO VOLTAGE PRESENT WHERE WORK IS TO BE PERFORMED. SPECIAL ATTENTION SHOULD BE PAID TO REVERSE FEED APPLICATIONS TO ENSURE NO VOLTAGE IS PRESENT.

Note: For new circuit breaker installation, the trip unit must be installed in circuit breaker before attempting to install a shunt trip. Refer to I.L. 29C607, I.L. 29C608, I.L. 29C609 or I.L. 29C610 for instructions on how to install trip unit.

- 2-1. Switch circuit breaker to OFF position.
- 2-2. Disconnect and remove circuit breaker from installation and terminal connections.
- 2-3. Remove cover screws and covers

Note: For a shunt trip having rear or opposite-side exiting pigtail leads, thread leads through center trough in side of base before attempting to insert the mounting bracket. Pigtail leads exiting in this manner should be eased through trough as mounting bracket is inserted into trip unit retaining slots. Use center trough also for leads exiting the side of the circuit breaker.

- 2-4. Route wiring to meet installation requirements. (See Fig. 2-2.):

**CAUTION**

LEADS SHOULD BE FORMED AND ROUTED TO CLEAR ALL MOVING PARTS WHEN ACCESSORY IS PROPERLY INSTALLED. PIGTAIL WIRES COULD BE DAMAGED IF IN CONTACT WITH MOVING PARTS.

IF SHUNT TRIP IS REMOVED FROM CIRCUIT BREAKER, INTERMEDIATE PLUNGER MUST ALSO BE REMOVED. FAILURE TO REMOVE THE INTERMEDIATE PLUNGER CAN RESULT IN EQUIPMENT DAMAGE.

- 2-5. Insert shunt trip as described in the following steps (Fig. 2-3).

**WARNING**

FAILURE TO KEEP FINGERS AWAY FROM MOVING PARTS CAN CAUSE PERSONAL INJURY. WHEN INTERMEDIATE PLUNGER IS POSITIONED IN TRIP UNIT, CIRCUIT BREAKER WILL MOVE TO THE TRIP POSITION. CARE SHOULD BE TAKEN TO KEEP FINGERS CLEAR OF CIRCUIT BREAKER MECHANISM PARTS AND HANDLE.

- a. Remove barrier from trip unit accessory mounting slots in pole being used for accessory.
- b. Position intermediate plunger in trip unit (Fig. 2-3).
- c. Trip circuit breaker by pressing intermediate plunger into recess in top of trip unit, and hold plunger in position.
- d. Slide shunt trip plug-in module into slots until retaining clip snaps into trip unit. Cutoff switch actuator must be above the crossbar. For terminal block assemblies, slide terminal block into mounting slot on side of base as plug-in module is being positioned.
- e. If required, complete routing of leads to opposite side through rear wiring trough.

**WARNING**

CONTACT WITH MOVING PARTS CAN CAUSE PERSONAL INJURY. WHEN CHECKING ACCESSORY, DO NOT PUT FINGERS NEAR MOVING PARTS INSIDE CIRCUIT BREAKER CASE. SPRINGS CAUSE INTERNAL PARTS TO MOVE QUICKLY AND WITH FORCE.

- 2-6. Perform mechanical check of shunt trip after installation:

- a. With the circuit breaker still electrically isolated, reset the circuit breaker.
- b. Using a small flat-blade screwdriver, depress solenoid plunger (Fig. 2-4). Circuit breaker should move to trip position.
- c. If mechanical check does not trip circuit breaker, see if shunt trip and intermediate plunger are correctly installed. If shunt trip and intermediate plunger appear to be properly installed and problem persists, contact Cutler-Hammer.

**CAUTION**

WHEN INSTALLING CIRCUIT BREAKER MAIN COVER, MAKE SURE THAT ALL INTERNAL PARTS ARE IN PLACE:

- **SLIDING HANDLE BARRIER IS POSITIONED SO THAT THE HANDLE OPENING IS ALIGNED WITH THE HANDLE.**
 - **ALL LEADS ARE CLEAR OF THE COVER.**
- 2-7. With circuit breaker handle in TRIPPED position and accessory pigtail leads (if used) routed as required, install circuit breaker covers. Secure with pan-head cover screws. Torque to 20-22 lb-in (2.26-2.49 N.m).

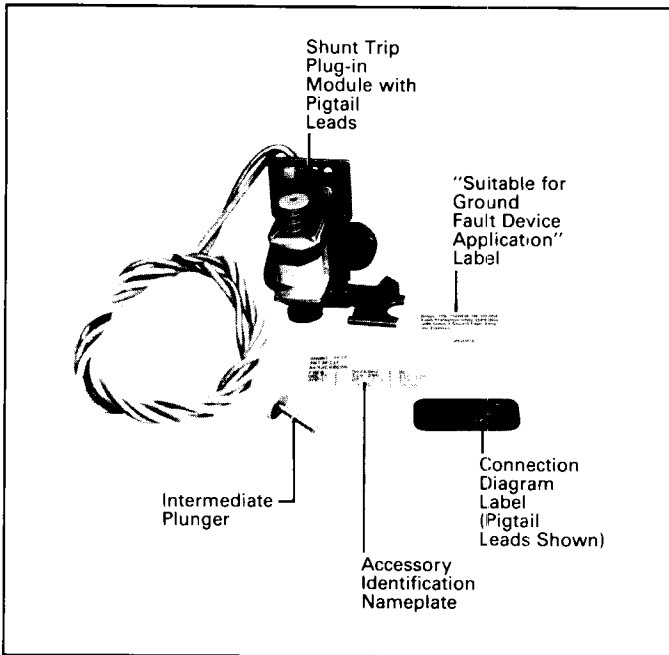

Fig. 2-1 Shunt Trip Kit

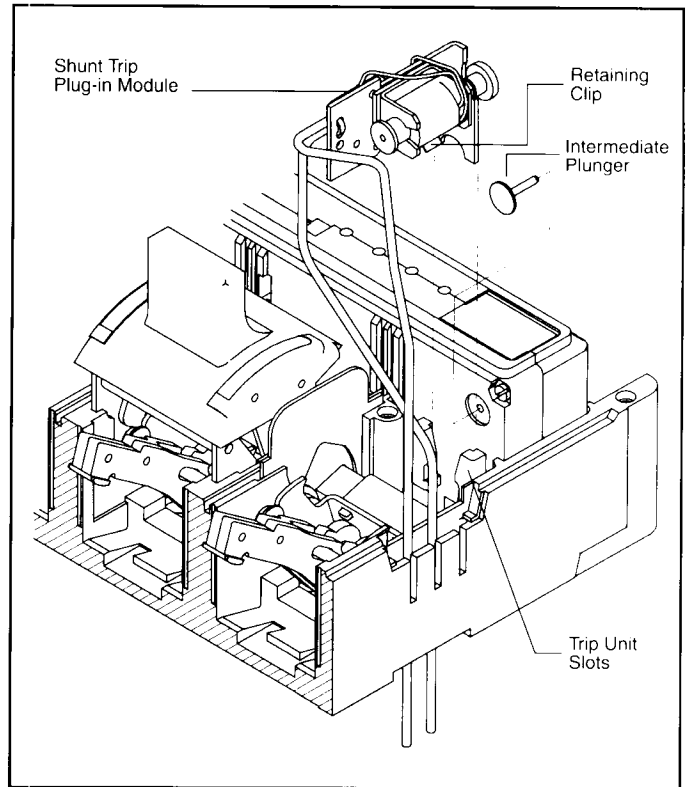

Fig. 2-3 Installing Intermediate Plunger and Shunt Trip

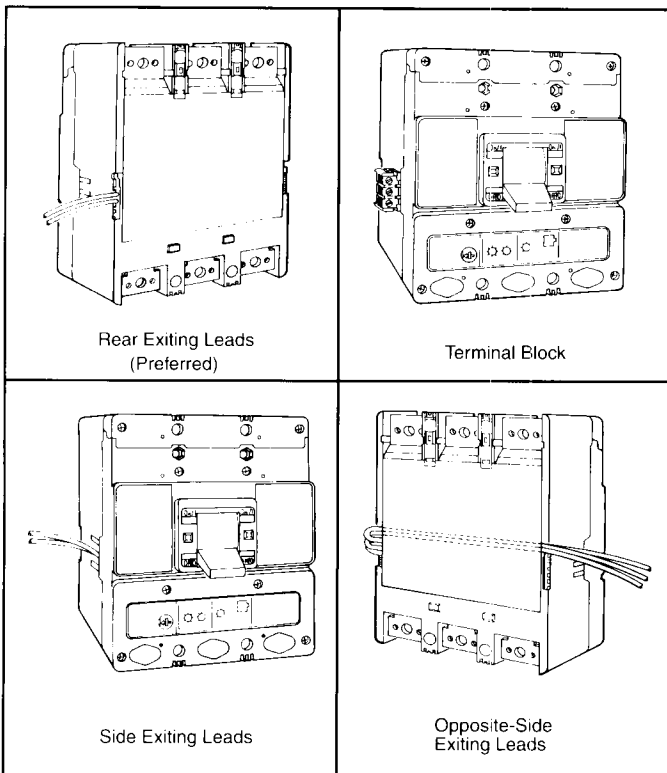

Fig. 2-2 Accessory Wiring Options

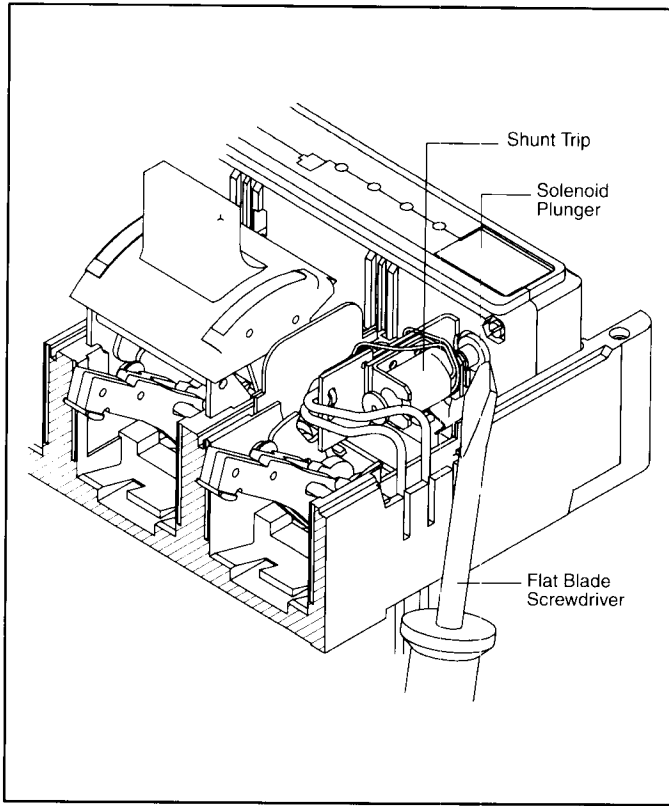

Fig. 2-4 Screwdriver Depressing Shunt Trip Solenoid Plunger

- 2-8. Remove and discard UL listing label on LDB circuit breakers only.
- 2-9. Place accessory labels (supplied with kit) on circuit breaker. (See Fig. 2-5.)

Note: Accessory labels show connection diagram for shunt trip. Pigtail leads are color coded white and yellow.

- 2-10. Test cutoff switch. Connect ohmmeter across pigtail leads or terminal block connections. Check continuity as follows:
 - a. Circuit breaker handle OFF – no continuity.
 - b. Circuit breaker handle ON – less than 9000 ohms.

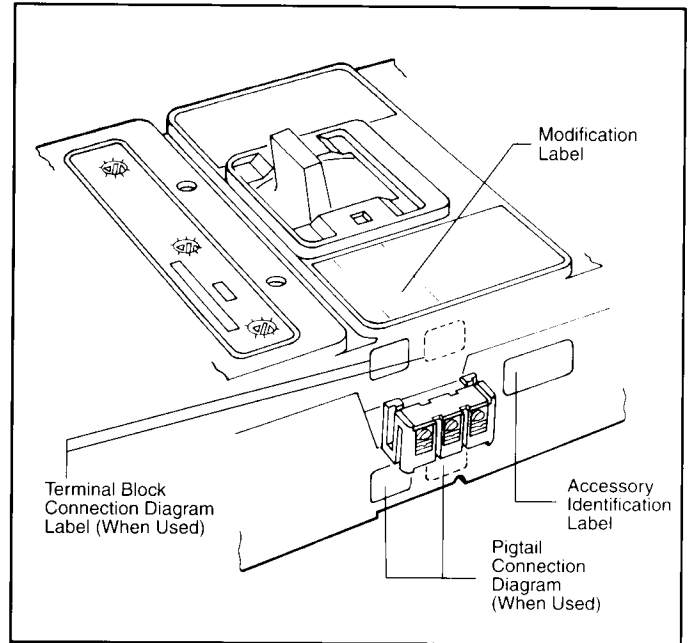

Fig. 2-5 Preferred Mounting Locations for Accessory Nameplate Labels

Note: For molded case switches, omit step c.

- c. Press PUSH-TO-TRIP button – no continuity.
- d. If cutoff switch fails test, make sure that shunt trip module is properly seated in trip unit slots. If problem persists, contact Cutler-Hammer.

2-11. Install circuit breaker.

2-12. Connect shunt trip as required (see Fig. 2-6).

Cutler-Hammer assumes no responsibility for malfunctioning accessories installed improperly by the customer.

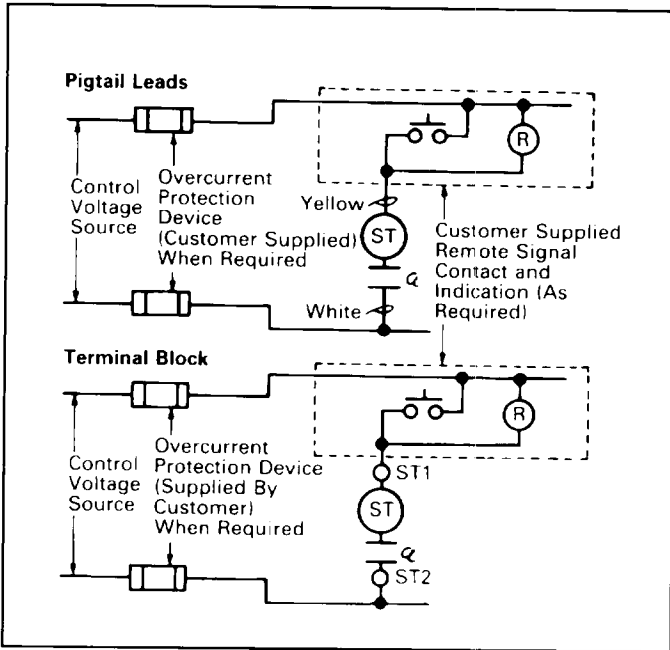

Fig. 2-6 Shunt Trip Connection Diagram

TABLE 1-1. SHUNT TRIP ELECTRICAL RATING DATA

- Average circuit breaker contact total opening time approximately 6 milliseconds, depending on voltage.
- Endurance – 400 electrical operations plus 5600 mechanical operations
- Shunt trip can be operated up to a maximum of six times per minute
- Maximum operating voltage – 110% of maximum voltage range rating
- Terminal block is approved for use with one or two No. 18 to No. 14 AWG solid or stranded copper wires.
Torque is 7 lb-in (0.8 Nm).

Catalog Suffix		Application Ratings		Electrical Operating Ratings							
Field Mounting Kit	Factory Installed	Voltage (V)	Frequency (Hz)	Supply Voltage (V)	Minimum Operating Voltage (V)	Ip (A)	Irms at 0.250s (A)	Irms at 0.033s (A)	VA	One Minute Dielectric Withstand Voltage (V)	
03K	03	12-24	50/60	9	6	7.2		5.1	46	1048	
				12		11.6		8.2			
				24		28.6		20.2			
		12-24	DC	9	6	8.5		75			
				12		8.6		103			
				24		17.4		418			
05K	05	48-60	50/60	48	34	0.72		0.51	25	1120	
				60		1.2		0.84			50
11K (1)	11(1)	110-240	50/60	110	77	0.89		0.63	69	1480	
				120		1.03		0.73			88
				127		1.1		0.80			102
				208		2.3		1.6			333
				220		2.4		1.7			374
				240		2.6		1.8			432
14K	14	380-440	50/60	380	266	0.30		0.21	80	1880	
				400		0.34		0.24			96
				415		0.35		0.25			104
				440		0.38		0.27			119
		220-250	DC	220	154	0.34		75			
				250		0.34		85			
18K	18	480-600	50/60	480	336	0.07		0.05	24	2200	
				525		0.07		0.05			26
				550		0.08		0.06			33
				600		0.11		0.08			48
23K	23	48-60	DC	48	34	0.76		0.36	36	1120	
				60		0.95		57			
26K	26	110-125	DC	110	77	0.42		46	46	1250	
				120		0.43		52			
				125		0.44		55			

Notes:

(1) Suitable for use with Class 1 GFP devices; marking label supplied with accessory kit.

Cutler-Hammer

Westinghouse & Cutler-Hammer Products

Distribution and Control Business Unit

Electrical Components Division

Pittsburgh, PA 15220

Style No. 6633C05H03