



This installation guide provides simple function information of PLC control. Please read carefully this data sheet and manuals before using products. Especially read safety precautions and handle the products properly.

1 Safety Precautions

■ Meaning of warning and caution inscription

	WARNING	WARNING indicates a potentially hazardous situation which, if not avoided, could result in death or serious injury.
	CAUTION	CAUTION indicates a potentially hazardous situation which, if not avoided, may result in minor or moderate injury. It may also be used to alert against unsafe practices.

⚠ WARNING	
①	Do not contact the terminals while the power is applied.
②	Protect the product from being gone into by foreign metallic matter.
③	Do not manipulate the battery(charge, disassemble, hitting, short, soldering).
⚠ CAUTION	
①	Be sure to check the rated voltage and terminal arrangement before wiring.
②	When wiring, tighten the screw of terminal block with the specified torque range.
③	Do not install the flammable things on surroundings.
④	Do not use the PLC in the environment of direct vibration.
⑤	Except expert service staff, do not disassemble or fix or modify the product.
⑥	Use the PLC in an environment that meets the general specifications contained in this datasheet.
⑦	Be sure that external load does not exceed the rating of output module.
⑧	When disposing of PLC and battery, treat it as industrial waste.

2 Use of Environment

■ To install, observe the below conditions.

No	Item	Specification	Standard			
1	Ambient temp.	0 ~ 55 °C	-			
2	Storage temp.	-25 ~ 70 °C	-			
3	Ambient humidity	5 ~ 95%RH, non-condensing	-			
4	Storage humidity	5 ~ 95%RH, non-condensing	-			
5	Vibration Resistance	Occasional vibration		10 times in each direction for X, Y, Z	IEC 61131-2	
		Frequency	Acceleration			Amplitude
		5≤f<8.4Hz	-			3.5mm
		8.4≤f≤150Hz	9.8m/s ² (1g)			-
		Continuous vibration				
		Frequency	Acceleration			Amplitude
5≤f<8.4Hz	-	1.75mm				
8.4≤f≤150Hz	4.9m/s ² (0.5g)	-				

3 Applicable Version

■ For system configuration, the following version is necessary.

- XBC Type : H(V2.2 or above), SU(V1.3 or above), U(V1.0 or above)
- XEC Type : H(V1.5 or above), SU(V1.1 or above), U(V1.0 or above)
- XG5000 Software : V4.0 or above

4 Parts Name and Dimension (mm)

■ This is front part of the Module. Refer to each name when driving the system. For more information, refer to user manual.

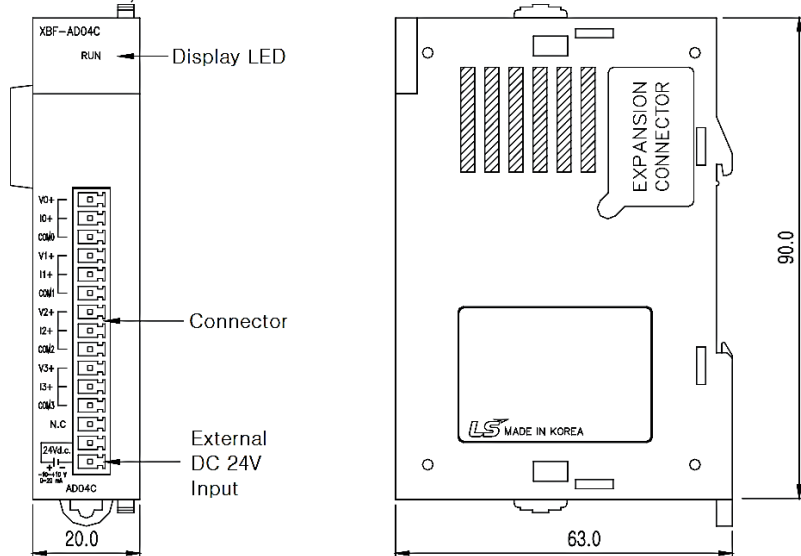

5 Mounting & Installation

■ Here describes the method to attach each product each product.

1) Attachment of product

- Eliminate the extension cover at the product.
- Push the product and connect it in agreement with hook for fixation of four edges and hook for connection at the bottom.
- After connection, push down the hook for fixation and fix it completely.

2) Detachment of product

- Push up the hook for disconnection, and then detach the product with two hands. (Do not detach the product by force)

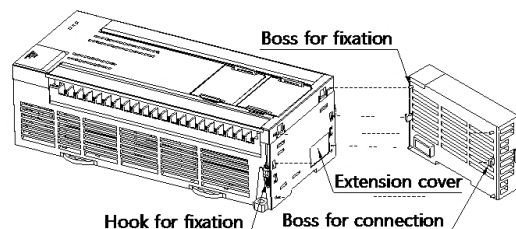

6 Performance Specifications

■ Performance specifications are as follows.

Item	Performance Specifications		
	Type	Voltage	Current
Analog input	Range	DC 1~5V	DC 4~20mA DC 0~20mA
		DC 0~5V	
		DC 0~10V	
		DC -10~10V	
Max. resolution	1/16,000		
Accuracy	±0.2% or less (When ambient temperature 25 °C) ±0.3% or less (When ambient temperature 0 ~ 55 °C)		
No. of channel	4		

7 Wiring

■ Installation of cable

- Don't let AC power line near to analog input module's external input signal line. With an enough distance kept away between, it will be free from surge or inductive noise.
- Cable shall be selected in due consideration of ambient temperature and allowable current. More than AWG22 (0.3mm²) is recommended.
- Don't let the cable too close to hot device and material or in direct contact with oil for long, which will cause damage or abnormal operation due to short-circuit.
- Check the polarity when wiring the terminal.
- Wiring with high-voltage line or power line may produce inductive hindrance causing abnormal operation or defect.
- Enable the channel that you want to use.

■ Wiring examples

1) Voltage input

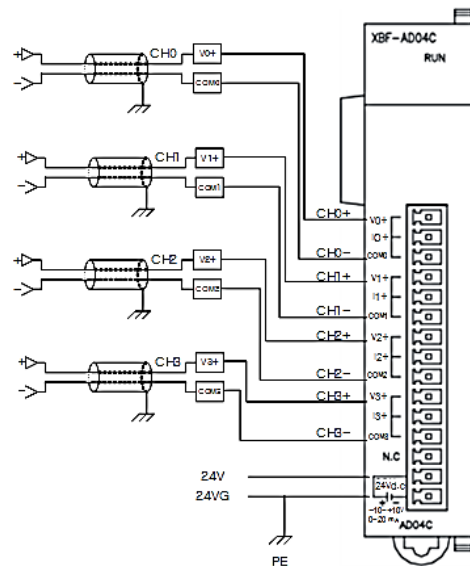

2) Current output

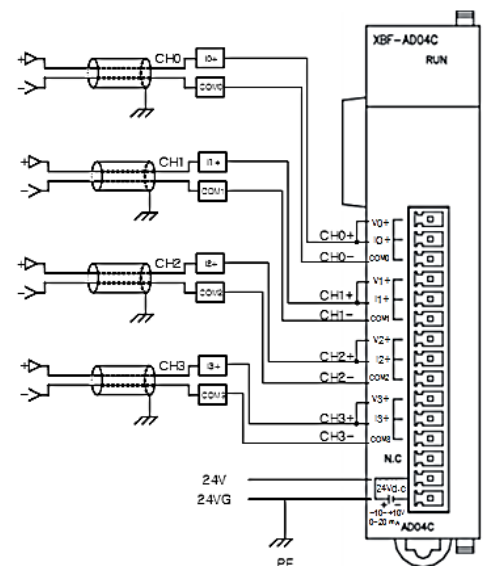

Notice

- Use the cable of 2-core twisted shield.
- AWG 22(0.3mm²) is recommended for the cable standard.
- Current input resistance is 250 Ω (typ.).
- Voltage input resistance is 1 MΩ (min.).
- Connect 24VG and PE of DC power supply for analog module.

8 Warranty

■ Warranty period

18 months after the production date.

■ Scope of Warranty

18-month warranty is available except:

- The troubles caused by improper condition, environment or treatment except the instructions of LS ELECTRIC.
- The troubles caused by external devices
- The troubles caused by remodeling or repairing based on the user's own discretion.
- The troubles caused by improper usage of the product
- The troubles caused by the reason which exceeded the expectation from science and technology level when LS ELECTRIC manufactured the product
- The troubles caused by natural disaster

■ Change in specifications

Product specifications are subject to change without notice due to continuous product development and improvement.

LS ELECTRIC Co., Ltd. www.lselectric.co.kr 10310001262 V4.3 (2020.4)

E-mail: automation@lselectric.co.kr



- Headquarter/Seoul Office
- LS ELECTRIC Shanghai Office (China)
- LS ELECTRIC (Wuxi) Co., Ltd. (Wuxi, China)
- LS-ELECTRIC Vietnam Co., Ltd. (Hanoi, Vietnam)
- LS ELECTRIC Middle East FZE (Dubai, U.A.E.)
- LS ELECTRIC Europe B.V. (Hoofddorf, Netherlands)
- LS ELECTRIC Japan Co., Ltd. (Tokyo, Japan)
- LS ELECTRIC America Inc. (Chicago, USA)

- Tel: 82-2-2034-4033, 4888, 4703
- Tel: 86-21-5237-9977
- Tel: 86-510-6851-6666
- Tel: 84-93-631-4099
- Tel: 971-4-886-5360
- Tel: 31-20-654-1424
- Tel: 81-3-6268-8241
- Tel: 1-800-891-2941

• Factory: 56, Samseong 4-gil, Mokcheon-eup, Dongnam-gu, Cheonan-si, Chungcheongnam-do, 31226, Korea