

Series

AQ58S and AQ59H

- Programmable incremental encoder
- Resolution from 1 to 16384 PPR (14-bit)
- Selectable index length 90 or 180°
- Pulse direction selectable cw, ccw
- Universal output circuit: 5–30 VDC Push-Pull (Totem Pole) or NPN/PNP open collector (HTL), or Line Driver (TTL)
- Quadrature output signals with index (ABZ, /ABZ)
- Programmable via USB cable
- IP65 protection

ENVIRONMENTAL SPECIFICATIONS

Shock:	100g, 6 ms
Vibrations:	10 g, 5-2000 Hz
Protection:	IP65
Operating temperature range:	-40°C to +85°C (-40°F to +185°F)
Storage temperature range:	-40°C to +100°C (-40°F to +212°F) (98% R.H. without condensation)

MECHANICAL SPECIFICATIONS

Dimensions:	see drawing
Shaft diameter:	Ø 3/8"
Hollow shaft diameter:	Ø 15mm (see optional reducers below)
Reducing sleeves BR1-xx, Ø 15mm to:	Ø 6, 8, 10, 11, 12 mm, 1/4", 3/8", 1/2"
Shaft loading (axial, radial):	100N max
Shaft rotational speed:	typical 6000 rpm / 12000 temporary.
Starting torque (at 20°C):	0.4 Ncm (typical)
Bearings life:	400 x 10 ⁶ rev. min (10 ⁹ rev. min. w/shaft loading limited to 20N)
Electrical connections:	M12 12-pin connector
Weight:	200g (7oz)

ELECTRICAL SPECIFICATIONS

Resolution (PPR):	programmable from 1 to 16384
Accuracy:	± 0.15°
Counting frequency:	500 kHz max.
Output circuits:	Universal output circuit: Push-Pull (Totem Pole) or NPN/PNP open collector (HTL), or Line Driver (TTL) Quadrature with index (ABZ, /ABZ)
Power supply:	+5VDC to +30VDC
Consumption:	60 mA (typical)
Output current (each channel):	40 mA max.
Protection:	against inversion of polarity and short-circuit
EMC:	electro-magnetic immunity, according to: EN 61000-4-2 EN 61000-4-4

MATERIALS

Flange:	anticorrosive, UNI EN AW-6082
Housing:	anticorrosive, UNI EN AW-6082
Bearings:	ABEC 5
Shaft:	stainless steel, non-magnetic – UNI EN 4305



AQ58S



AQ59

ACCESSORIES

BR1-xx	Reducer bushings, from 6mm up to 1/2" options available (AQ59H)
PF4256	61mm bolt hole circle, round mount (AQ58S)
PF0408	spring loaded mount (AQ58S)
PF4257	right angle bracket (AQ58S)
PF4259	92mm bolt hole circle, square mount (AQ58S)
PF4274	70mm bolt hole circle, round mount (AQ58S)
PF4258	75 and 100 mm bolt hole circle, round mount (AQ58S)
PF5000-A	74.1mm bolt hole circle, square mount (AQ58S)
LKM-386	servo mount clamp (AQ58S)
KIT-XX59	servo mount clamp (AQ58S, 59H)
KIT-IP/IQ58	USB-A to 4-position terminal block (AQ58S, 59H)
EC-IP/IQ58-M12	programming cable, M12 to pigtail (AQ58S, 59H)
KIT-IP/IQ58-USB-M12	USB-A to M12 female cable (AQ58S, 59H)
EC-M12F12-LKT12-05	5m M12 female to pigtail (AQ58S, 59H)
EC-M12F12-LKT12-10	10m M12 female to pigtail (AQ58S, 59H)

AVAILABLE MODELS	SHAFT TYPE	MODEL-SPECIFIC DRAWINGS
AQ58S-PRG-HZCP9-M12	Solid	PDF
AQ59H-PRG-HZC15-M12	Hollow	PDF

AQ58S-PRG-HZCP9-M12 Dimensions

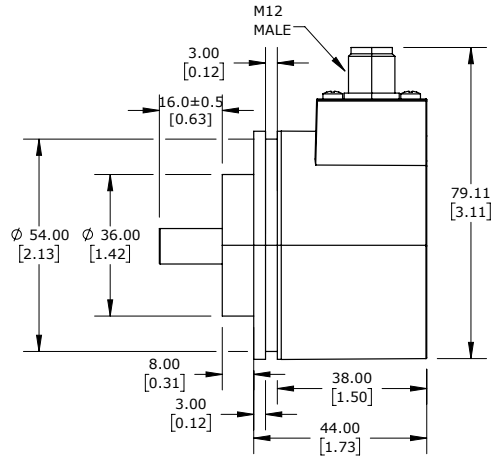
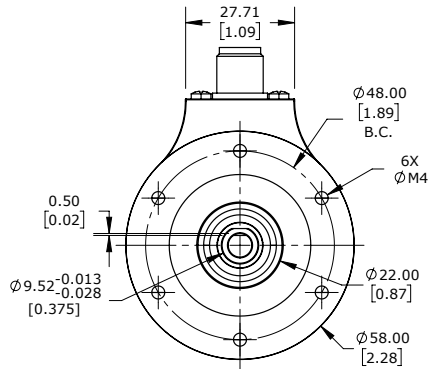
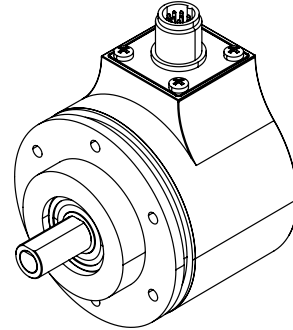
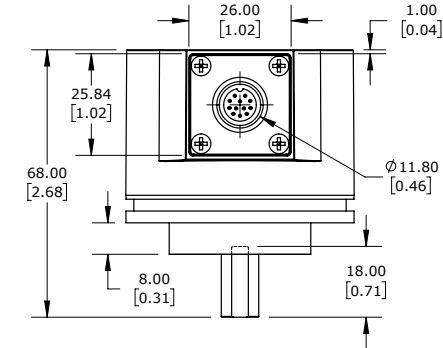

AQ59H-PRG-HZC15-M12 Dimensions

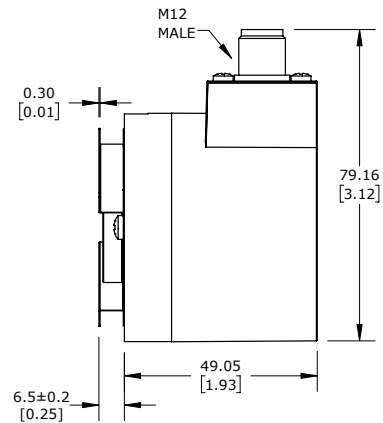
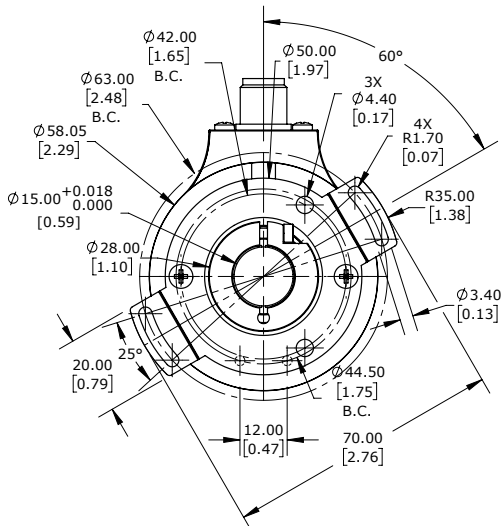
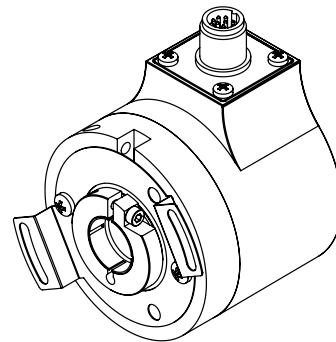
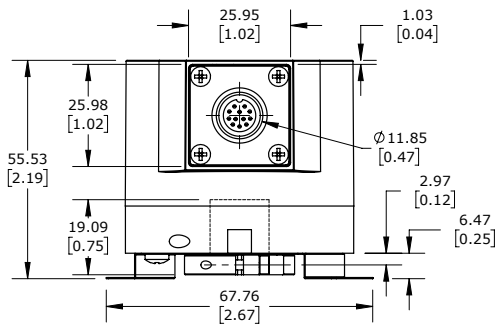

AQ58S Mounting Instructions



EN	Mounting Instructions
	<ul style="list-style-type: none"> Mount the flexible coupling (1) on the encoder shaft; Fix the encoder to the flange (2) (or to the mounting bell) by means of screws type M4 (3); Mount the flexible coupling (1) on the motor shaft, then secure the flange (2) to the support (or the mounting bell to the motor); Make sure the misalignment tolerances of the flexible coupling (1) are respected.

IT	Istruzioni di montaggio
	<ul style="list-style-type: none"> Fissare il giunto elastico (1) all'encoder; Fissare l'encoder alla flangia di fissaggio (2) o alla campana utilizzando le viti tipo M4 (3); Fissare il giunto elastico (1) al motore, poi fissare la flangia (2) al supporto o la campana al motore; Assicurarsi che le tolleranze di disallineamento ammesse dal giunto elastico (1) siano rispettate.

DE	Montagehinweise
	<ul style="list-style-type: none"> Die Kupplung (1) auf den Geber montieren; Geber mit dem Flansch (2) bzw. der Montageglocke mittels Schrauben M4 (3) verschrauben; Die Kupplung (1) auf die Motorwelle montieren und den Flansch (2) auf seiner Auflage bzw. die Montageglocke am Motor fixieren; Es muss sichergestellt sein, dass die zulässigen Toleranzen der Kupplung (1) eingehalten werden.

ES	Instrucciones de montaje
	<ul style="list-style-type: none"> Montar el acoplamiento elástico (1) en el eje del encoder; Fijar el encoder a la brida (2) (o a la campana) mediante los tornillos tipo M4 (3); Montar el acoplamiento elástico (1) en el eje del motor, después fijar la brida (2) al soporte (o la campana al motor); Asegurarse de que se respetan las tolerancias de desalineación del acoplamiento elástico (1).

FR	Instructions de montage
	<ul style="list-style-type: none"> Monter le joint élastique (1) sur l'arbre du codeur; Fixer le codeur à la bride (2) (ou à la cloche de montage) au moyen des vis type M4 (3); Monter le joint élastique (1) sur l'arbre du moteur, puis fixer la bride (2) au support (ou la cloche de montage au moteur); S'assurer que les tolérances de mauvais alignement admises par le joint élastique (1) soient respectées.



AQ58S Mounting

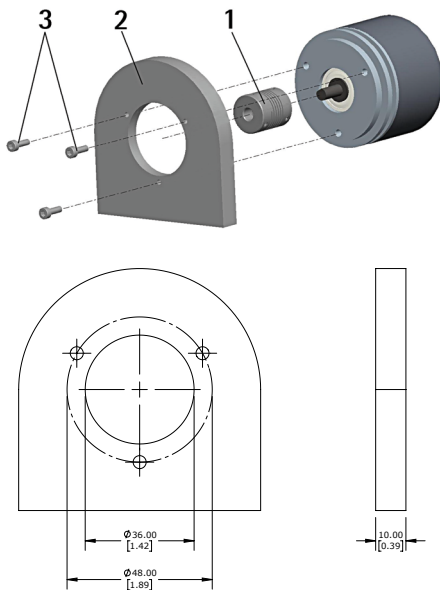

AQ58S Mounting with fixing clamps (LKM-386)

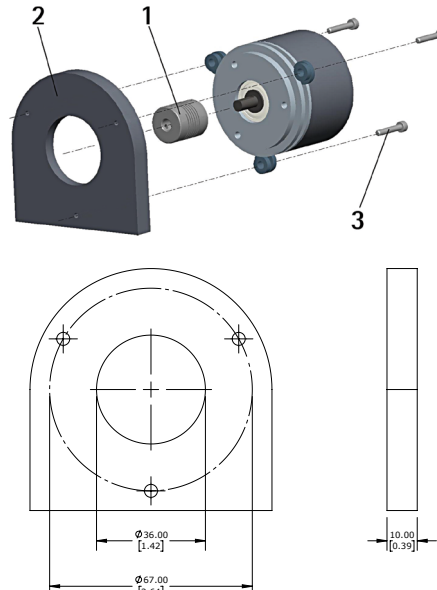

AQ58S Mounting with mounting bell (PF4256)

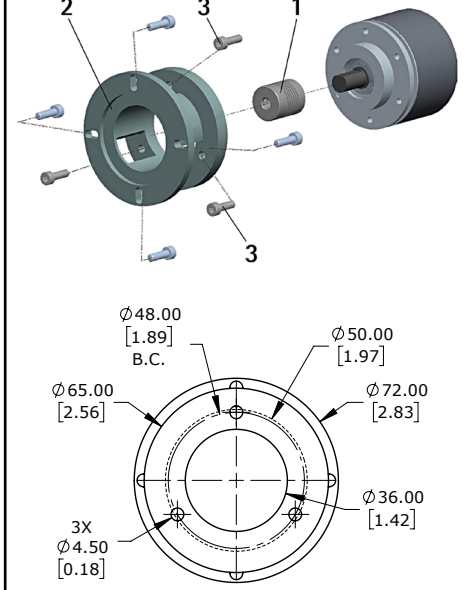

Electrical-connections													
Signals	A	/A	B	/B	Z	/Z	+5 Vdc +30 Vdc	0 Vdc	N/C**	N/C**	SDA	SCL*	Shield
M12 12-pin	3	4	5	6	9	10	2	1	7	8	11	12	Case
EC-M12F12-LKT12-xx Wire Colors	Violet	Yellow	Grey	Pink	Green	Brown	Brown/ Green	White/ Green	White	Blue	Red	Black	-

* Installation has to be carried out with power supply disconnected.
L'installazione deve essere eseguita in assenza di tensione.
Der Anschluss darf nur bei ausgeschalteter Versorgungsspannung erfolgen.
La instalación sólo debe ser efectuada en ausencia total de tensión.
Le montage du dispositif doit être effectué en absence totale de tension.
** No connection

Connector type
Male frontal side
Maschio lato contatti
Aufsicht Stiftseite
Macho lado contactos
Mâle côté contacts

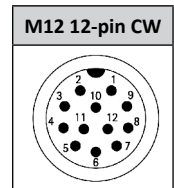

Ground connection

Minimize noise by connecting the shield and/or the connector housing and/or the frame to ground. Make sure that ground is not affected by noise. The connection point to ground can be situated both on the device side and on user's side. The best solution to minimize the interference must be carried out by the user. You should provide the ground connection as close as possible to the encoder.

Programming software downloadable from AutomationDirect.com.

Use one of the following methods to configure the encoder:

- KIT-IP/IQ58-USB-M12 programming cable.
- Combination of KIT-IP/IQ58 and EC-IP/IQ58-M12 programming kit.
- Combination of KIT-IP/IQ58 and EC-M12F12-LKT12-xx cable.

AQ59H Mounting Instructions



EN	Mounting Instructions
	<ul style="list-style-type: none"> Mount the encoder on the motor shaft using the reducing sleeve (4) (if supplied). Avoid forcing the encoder shaft; Fasten the fixing plate (2) to the rear of the motor using two M3 cylindrical head screws (3); Fix the collar (1) to the encoder shaft.

IT	Istruzioni di montaggio
	<ul style="list-style-type: none"> Inserire l'encoder sull'albero del motore utilizzando la boccola di riduzione (4) (se fornita). Evitare sforzi sull'albero encoder; Fissare la molla di fissaggio (2) sul retro del motore utilizzando due viti M3 a testa cilindrica (3); Fissare il collare (1) dell'albero encoder.

DE	Montagehinweise
	<ul style="list-style-type: none"> Geber und Reduzierhülse (4) (wenn erforderlich) auf die Motorwelle montieren. Belastungen der Geberwelle vermeiden; Drehmomentstütze (2) auf der Rückseite des Motors mit zwei M3 Zylinderschrauben (3) befestigen; Klemmflansch (1) festschrauben.

ES	Instrucciones de montaje
	<ul style="list-style-type: none"> Montar el encoder y el manguito reductor (4) (si se suministra) en el eje del motor sin forzar el eje del encoder; Fijar la placa de fijación (2) en la parte posterior del motor mediante los dos tornillos (3) de cabeza cilíndrica tipo M3; Fijar el collar (1) de el eje encoder.

FR	Instructions de montage
	<ul style="list-style-type: none"> Monter le codeur et la douille de réduction (4) (si fournie) sur l'arbre moteur sans forcer l'arbre du codeur; Fixer la plaquette de fixation (2) à la partie postérieure du moteur en utilisant deux vis type M3 à tête cylindrique (3); Fixer le collier (1) de l'arbre codeur.

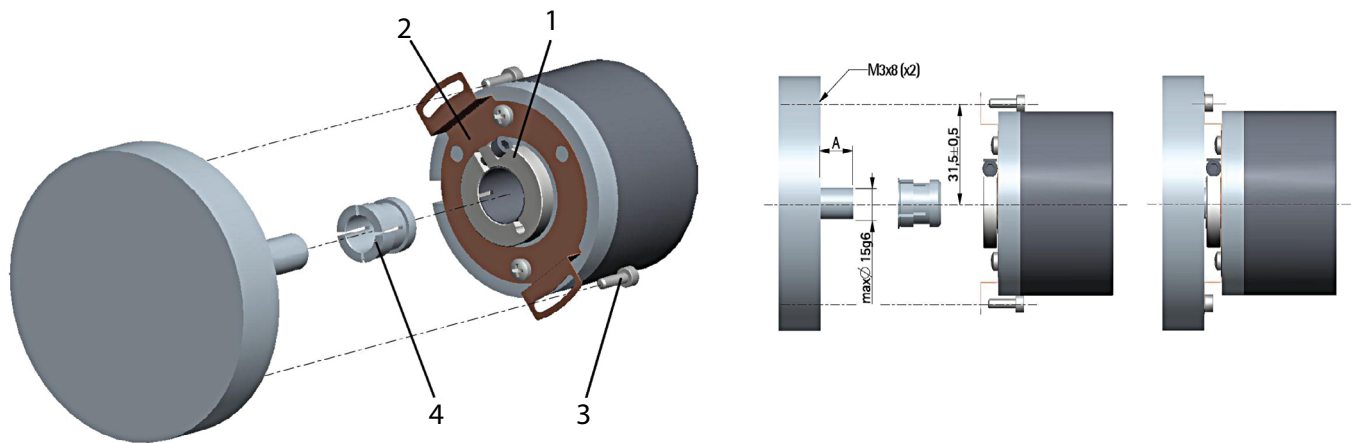

Electrical-connections													
Signals	A	/A	B	/B	Z	/Z	+5 Vdc +30 Vdc	0 Vdc	N/C**	N/C**	SDA	SCL*	Shield
M12 12-pin	3	4	5	6	9	10	2	1	7	8	11	12	Case
EC-M12F12-LKT12-xx Wire Colors	Violet	Yellow	Grey	Pink	Green	Brown	Brown/ Green	White/ Green	White	Blue	Red	Black	-

* Installation has to be carried out with power supply disconnected.
L'installazione deve essere eseguita in assenza di tensione.
Der Anschluss darf nur bei ausgeschalteter Versorgungsspannung erfolgen.
La instalación sólo debe ser efectuada en ausencia total de tensión.
Le montage du dispositif doit être effectué en absence totale de tension.

** No connection

Connector type
Male frontal side
Maschio lato contatti
Aufsicht Stiftseite
Macho lado contactos
Mâle côté contacts

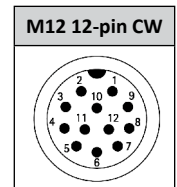

Ground connection

Minimize noise by connecting the shield and/or the connector housing and/or the frame to ground. Make sure that ground is not affected by noise. The connection point to ground can be situated both on the device side and on user's side. The best solution to minimize the interference must be carried out by the user. You should provide the ground connection as close as possible to the encoder.

Programming software downloadable from AutomationDirect.com.

Use one of the following methods to configure the encoder:

- KIT-IP/IQ58-USB-M12 programming cable.
- Combination of KIT-IP/IQ58 and EC-IP/IQ58-M12 programming kit.
- Combination of KIT-IP/IQ58 and EC-M12F12-LKT12-xx cable.

Universal Output Encoder Wiring Diagrams

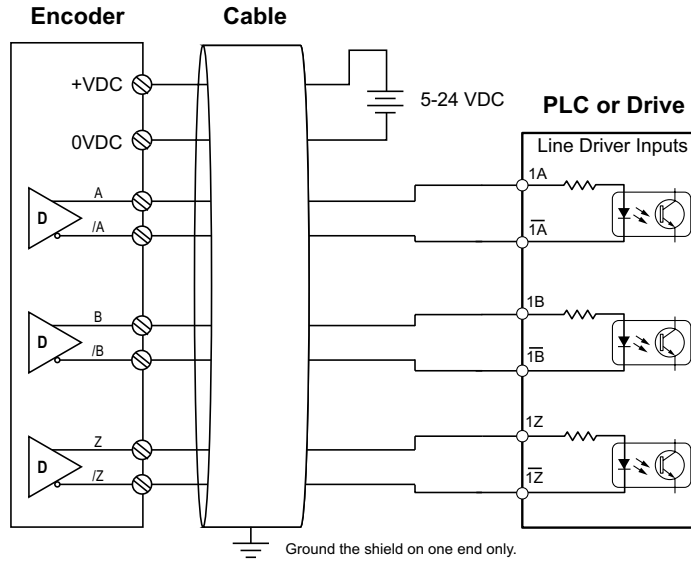

Line Driver Wiring

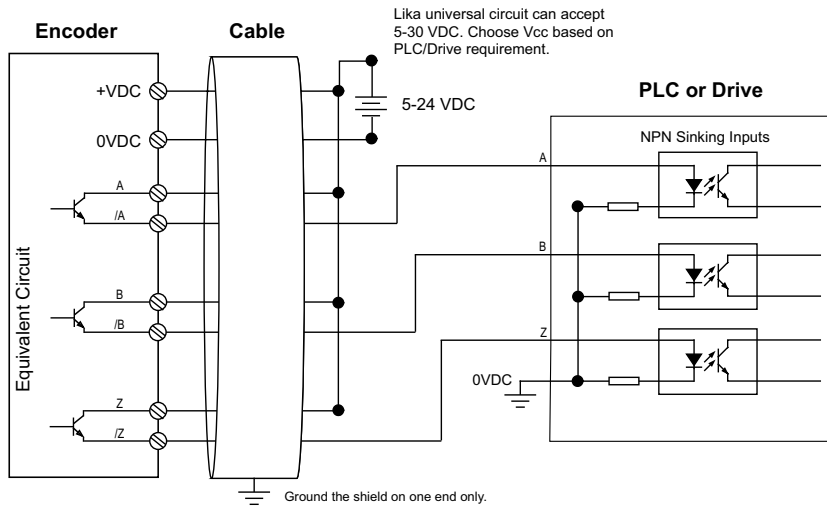

Sinking Input Wiring

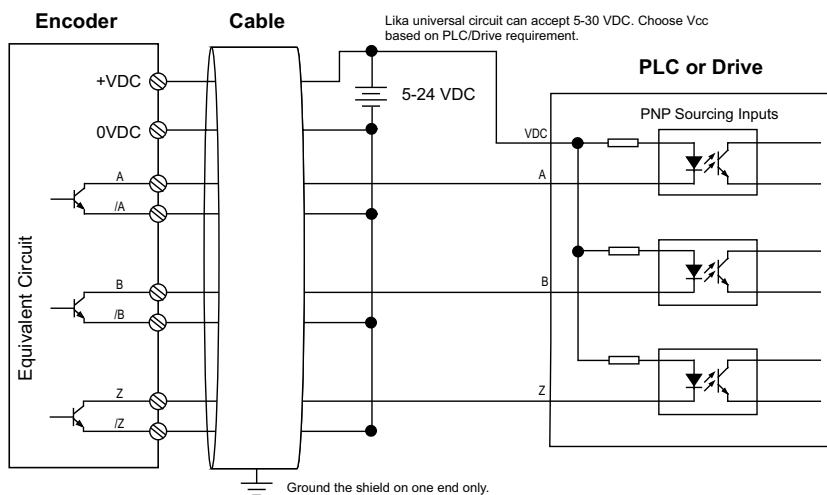

Sourcing Input Wiring

Safety		EN	IT
<ul style="list-style-type: none"> Always adhere to the professional safety and accident prevention regulations applicable to your country during device installation and operation; Installation has to be carried out by qualified personnel only, with power supply disconnected and stationary mechanical parts; The encoder must be used only for the purpose appropriate to its design: use for purposes other than those for which it has been designed could result in serious personal and/or the environment damage; High current, voltage and moving mechanical parts can cause serious or fatal injury; Warning! Do not use in explosive or flammable areas; Failure to comply with these precautions or with specific warnings elsewhere in this manual violates safety standards of design, manufacture, and intended use of the equipment; Lika Electronic assumes no liability for the customer's failure to comply with these requirements. 			
Electrical Safety			
<ul style="list-style-type: none"> Turn OFF the power supply before connecting the device; Connect according to the explanation in the "Electrical connections" section; Wires of output signals which are not used must be cut at different lengths and insulated singularly; In compliance with 2014/30/EU norm on electromagnetic compatibility, the following precautions must be taken: <ul style="list-style-type: none"> Before handling and installing the equipment, discharge electrical charge from your body and tools which may come in touch with the device; Power supply must be stabilized without noise; install EMC filters on device power supply if needed; Always use shielded cables (twisted pair cables whenever possible); Avoid cables runs longer than necessary; Avoid running the signal cable near high voltage power cables; Mount the device as far as possible from any capacitive or inductive noise source; shield the device from noise source if needed; To guarantee a correct working of the device, avoid using strong magnets on or near by the unit; Minimize noise by connecting the shield or the connector housing and the frame to ground. Make sure that ground is not affected by noise. The connection point to ground can be situated both on the device side and on user's side. The best solution to minimize the interference must be carried out by the user. 			

Mechanical Safety	
<ul style="list-style-type: none"> Install the device following strictly the information in the "Mounting instructions" section; Mechanical installation has to be carried out with stationary mechanical parts; Do not disassemble the device; do not tool the device or its shaft; Delicate electronic equipment: handle with care; do not subject the device and the shaft to knocks or shocks; Respect the environmental characteristics of the product. 	

Sicherheitshinweise		DE	ES
<ul style="list-style-type: none"> Während der Installation und des Betriebes müssen alle allgemeinen, sowie länderspezifischen und anwendungsspezifischen Sicherheitsbestimmungen und Unfallverhütungsvorschriften beachtet werden; das Gerät darf nur bei ausgeschalteter Versorgungsspannung und stehende mechanische Teile von einer Elektrofachkraft eingebaut, angeschlossen und in Betrieb genommen werden; der Einsatz des Gebers ist nur bei bestimmungsgemäßer Verwendung zulässig; hohe Ströme, Spannungen und bewegte mechanische Teile können schwere oder sogar tödliche Verletzungen verursachen; Achtung! Nicht in feuer- oder explosionsgefährdeten Bereichen betreiben; die Nichteinhaltung dieser Vorsichtsmaßnahmen und anderer ausdrücklicher Warnhinweise in diesem Dokument, bedeutet eine Verletzung der Sicherheitsbestimmungen und stellt somit eine nicht bestimmungsgemäße Verwendung dar; Lika Electronic übernimmt keine Verantwortung für Ausfälle seitens des Kunden, bei Nichteinhaltung dieser Vorschriften. 			

Elektrische Sicherheit	
<ul style="list-style-type: none"> Spannungsversorgung ausschalten bevor das Gerät angeschlossen wird; Verdrahtung gemäß den Vorgaben im Abschnitt „Electrical connections“ vornehmen; Andern die nicht gebraucht werden, müssen einzeln isoliert werden; in Übereinstimmung mit der Norm 2014/30/EU müssen folgende Vorsichtsmaßnahmen beachtet werden: <ul style="list-style-type: none"> Sichere Entladung aller elektrisch geladenen Teile, die mit dem Gerät bei seiner Handhabung und Installation in Berührung kommen; die Spannungsversorgung muss stabilisiert und geglättet sein. Wenn nötig, müssen zusätzliche EMC-Filter montiert werden; Es dürfen nur geschirmte und möglichst paarig verdrehte Leitungen verwendet werden; unnötig lange Kabel sind zu vermeiden; die parallele Verlegung von Signal- und Leistungskabeln ist zu vermeiden; das Gerät sollte soweit wie möglich von kapazitiven und induktiven Störquellen entfernt montiert werden. Wenn erforderlich, muss das Gerät gegen die Störquellen abgeschirmt werden; um eine störungsfreie Funktion zu gewährleisten, ist der Betrieb in - oder in der Nähe von - starken Magnetfeldern zu vermeiden; Störungen können häufig minimiert werden, indem die Abschirmung des Geberkabels und/ bzw. das Steckergehäuse und/ bzw. der Rahmen mit GND verbunden wird. Es muss hierfür sichergestellt sein, dass der GND nicht mit Störungen belastet ist. Ob der Schirm ein- oder beidseitig aufgelegt wird ist anlagenspezifisch und muss bei der Installation festgelegt werden. 	

Mechanische Sicherheit	
<ul style="list-style-type: none"> Der Einbau des Gerätes muss unter strikter Beachtung des Kapitels „Montagehinweise“ erfolgen; das Gerät darf nur bei stehende mechanische Teile eingebaut werden; der Geber darf nicht zerlegt werden; der Geber und seine Welle dürfen nicht bearbeitet werden; empfindlich elektronisch Gerät: pfleglich zu behandeln; Geber und Welle dürfen keinen Stößen oder Schlägen ausgesetzt werden; die produktspezifischen Umgebungsbedingungen müssen beachtet werden. 	

Avvertenze	
<ul style="list-style-type: none"> Durante l'installazione e l'utilizzo del dispositivo osservare le norme di prevenzione e sicurezza sul lavoro previste nel proprio paese; l'installazione deve essere eseguita da personale qualificato, in assenza di tensione e parti meccaniche in movimento; Utilizzare il dispositivo esclusivamente per la funzione per cui è stato costruito: ogni altro utilizzo potrebbe risultare pericoloso per l'utilizzatore; Alte correnti, tensioni e parti meccaniche in movimento possono causare lesioni serie o fatali; Non utilizzare in ambienti esplosivi o infiammabili; Il mancato rispetto delle norme di sicurezza o delle avvertenze specificate in questo manuale è considerato una violazione delle norme di sicurezza standard previste dal costruttore o richieste dall'uso per cui lo strumento è destinato; Lika Electronic non si assume alcuna responsabilità per eventuali danni o lesioni derivanti dall'inosservanza delle norme di sicurezza da parte dell'utilizzatore. 	

Avvertenze elettriche	
<ul style="list-style-type: none"> Effettuare le connessioni elettriche esclusivamente in assenza di tensione; Rispettare le connessioni riportate nella sezione "Electrical connections"; I fili dei segnali d'uscita non utilizzati devono essere isolati singolarmente; In conformità alla normativa 2014/30/UE sulla compatibilità elettromagnetica rispettare le seguenti precauzioni: <ul style="list-style-type: none"> Prima di maneggiare e installare il dispositivo, eliminare la presenza di carica elettrostatica dal proprio corpo e dagli utensili che verranno in contatto con il dispositivo; Alimentare il dispositivo con tensione stabilizzata e priva di disturbi, se necessario, installare appositi filtri EMC all'ingresso dell'alimentazione; Utilizzare sempre cavi schermati e possibilmente "twistati"; Non usare cavi più lunghi del necessario; Evitare di far passare il cavo dei segnali del dispositivo vicino a cavi di potenza; Installare il dispositivo il più lontano possibile da eventuali fonti di interferenza o schermarlo in maniera efficace; Per garantire un funzionamento corretto del dispositivo, evitare l'utilizzo di apparecchiature con forte carica magnetica in prossimità dell'unità; Collegare la calza del cavo o la custodia del connettore e il corpo del dispositivo a un buon punto di terra; assicurarsi che il punto di terra sia privo di disturbi. Il collegamento a terra può essere effettuato sul lato dispositivo e/o sul lato utilizzatore; è compito dell'utilizzatore valutare la soluzione migliore da adottare per minimizzare i disturbi. 	

Avvertenze meccaniche	
<ul style="list-style-type: none"> Montare il dispositivo rispettando rigorosamente le istruzioni riportate nella sezione "Istruzioni di montaggio"; Effettuare il montaggio meccanico esclusivamente in assenza di parti meccaniche in movimento; Non disassemblare il dispositivo; non eseguire lavorazioni meccaniche sul dispositivo; Dispositivo elettronico delicato: maneggiare con cura; evitare urti o forti sollecitazioni sia all'albero che al corpo del dispositivo; Utilizzare il dispositivo in accordo con le caratteristiche ambientali dello stesso. 	

Seguridad	
<ul style="list-style-type: none"> Durante la instalación y uso del dispositivo observar las normas de prevención de riesgos y seguridad laboral vigentes en el país; la instalación sólo debe ser efectuada por personal cualificado, en ausencia total de tensión y con el eje inmóvil; utilizar el dispositivo exclusivamente para la función para la que ha sido construido: cada uso diferente puede resultar peligroso para el usuario; altas corrientes, voltajes y componentes mecánicos en movimiento pueden causar lesiones serias o incluso fatales; atención: no utilice el dispositivo en lugares inflamables y explosivos; la inobservancia de las normas de seguridad y de las advertencias mencionadas en este manual resulta en la violación de las normas básicas de seguridad y salud previstas por el constructor o requeridas por la función para la que el dispositivo ha sido construido; Lika Electronic no asume responsabilidad por eventuales daños, perjuicios o lesiones que pueden derivarse de la inobservancia de las normas de seguridad por el usuario. 	

Seguridad eléctrica	
<ul style="list-style-type: none"> Efectuar la conexión eléctrica exclusivamente en ausencia de tensión; respetar las conexiones según se indican en la tabla "Electrical connections"; los hilos no usados de los señales de salida deben ser aislados individualmente; en conformidad con la norma 2014/30/UE sobre la compatibilidad electromagnética se deben respetar las siguientes precauciones: <ul style="list-style-type: none"> antes de manejar e instalar el dispositivo, elimine cualquier carga electrostática de su propio cuerpo y de las herramientas que entrarán en contacto con el dispositivo; alimente el dispositivo con tensión estabilizada y libre de ruido; de ser necesario, instale filtros EMC en la entrada de la alimentación; utilice cables apantallados y trenzados siempre que sea posible; no use cables más largos de lo necesario; evite pasar el cable de señal del dispositivo cerca de los cables de potencia; instale el dispositivo lo más lejos posible de potenciales fuentes de interferencia, o apantálalo de forma eficaz; para garantizar el correcto funcionamiento del dispositivo, evite el uso de instrumentos que tienen carga eléctrica intensa cerca de la unidad; conecte la malla del cable y/o la carcasa del conector y/o el cuerpo del dispositivo a una buena toma de tierra; asegúrese de que la toma de tierra esté libre de ruido. La conexión a tierra puede efectuarse en el lado encoder y/o en el lado usuario, es el usuario quien ha de valorar la mejor solución a adoptar para minimizar el ruido. 	

Seguridad mecánica	
<ul style="list-style-type: none"> Montar el dispositivo, tal como se indica en la sección "Instrucciones de montaje"; la instalación mecánica sólo debe ser efectuada con componentes mecánicos inmóviles; no desensamblar el dispositivo; no realizar trabajos mecánicos sobre el dispositivo o el eje; dispositivo electrónico delicado: manejar con cuidado; evitar golpes tanto sobre el eje como sobre el cuerpo del dispositivo; utilizar el dispositivo respetando sus características ambientales. 	

Mesures de sécurité		FR
<ul style="list-style-type: none"> Pendant l'installation et l'utilisation du dispositif veuillez observer les réglementations préventives en matière de sécurité et d'accident en vigueur dans votre pays; le montage du dispositif doit être pris en charge par un spécialiste ayant des connaissances en électricité et en mécanique; avant d'installer le dispositif s'assurer qu'il y a absence de tension et composants mécaniques à l'arrêt; il est défendu d'utiliser le dispositif en manière pas conforme à l'usage prévu par le constructeur: toute utilisation différente pourrait engendrer des risques sérieux pour les personnes et/ou l'environnement; hautes tensions, voltages élevés et composants en mouvement peuvent engendrer des risques sérieux ou fatals pour les personnes; il est défendu d'utiliser le dispositif dans un milieu explosif; la non-observance des normes de sécurité ou bien des avertissements spécifiés dans ce manuel sera considérée une violation des normes de sécurité fondamentales prévues par le constructeur ou bien requêtes pour l'usage prévu du dispositif; la Société Lika Electronic nie toute responsabilité pour tout dommage ou blessure que l'utilisateur peut encourir à la suite de la non-observance des normes de sécurité. 		

Précautions électriques	
<ul style="list-style-type: none"> Il est absolument défendu d'effectuer les connexions électriques lorsque le système est sous tension; respecter les instructions de connexion mentionnées dans la section « Electrical connections »; les câbles des signaux en sortie qui ne sont pas utilisés doivent être isolés singulièrement aux extrémités; en conformité avec la norme 2014/30/UE concernant la compatibilité électromagnétique respecter les précautions suivantes: <ul style="list-style-type: none"> avant de manipuler ou bien installer le dispositif, éliminer la charge électrostatique présente au niveau du corps de l'utilisateur ou bien des outils qui seront en contact avec le dispositif; relier le dispositif au réseau électrique en s'assurant qu'il soit stabilisé et absent de dérangements; s'il s'avère nécessaire, installer des filtres EMC à l'entrée du réseau d'alimentation; toujours utiliser des câbles blindés et, si possible, torsadés; ne pas utiliser des câbles plus longs que le nécessaire; s'assurer que le câble qui porte les signaux du dispositif ne soit pas placé à côté ou bien en proximité des câbles de puissance; installer le dispositif loin des composants qui peuvent causer des dérangements ou bien le blinder soigneusement; afin de garantir un fonctionnement correct de l'appareil on conseille de n'utiliser pas des équipements possédants une forte charge électromagnétique en proximité de l'unité; connecter le blindage du câble et/ou la protection du connecteur et/ou le corps du dispositif à la borne de la mise à terre; s'assurer que la borne de la mise à terre soit absente de dérangements. Le raccordement de la borne de la mise à terre peut être effectué sur le côté codeur et/ou sur le côté utilisateur; l'utilisateur est chargé de mieux évaluer la solution meilleure afin de éliminer ou minimiser les dérangements. 	

Précautions mécaniques	
<ul style="list-style-type: none"> Installer le dispositif en respectant soigneusement les instructions de montage dans la section « Instructions de montage »; le montage mécanique du dispositif doit être effectué avec composants mécaniques à l'arrêt; ne démonter pas le dispositif; ne pas exécuter des usinages sur le dispositif; dispositif électronique fragile: manipuler avec soin; éviter tout coup et sollicitation qui peuvent endommager l'arbre et le corps; utiliser le dispositif tout en respectant les caractéristiques environnementales mentionnées par le constructeur. 	



This device is to be supplied by a Class 2 Circuit or Low-Voltage Limited Energy or Energy Source not exceeding 30 Vdc. Refer to the order code for supply voltage rate.

Ce dispositif doit être alimenté par un circuit de Classe 2 ou à très basse tension ou bien en appliquant une tension maxi de 30Vcc. Voir le code de commande pour la tension d'alimentation.



Lika Electronic reserves the right to make changes in specifications without prior notice - Lika Electronic si riserva il diritto di apportare modifiche senza preavviso - Die Fa. Lika Electronic behält sich das Recht zu Änderungen ohne Vorankündigung vor - Informaciones pueden ser modificadas por Lika Electronic sin previo aviso - Les informations peuvent être modifiées par Lika Electronic sans avis préalable