

DATA SHEET

Premium Efficiency Motor: **MTSP-P75-3BD12**

60 Hz

Document Generated: 9-Nov-2020
Document ID:

Customer:

MOTOR INFORMATION

HP	3/4
RPM	1200
Phase	3
Frequency	60
Voltage	230/460
Frame Size	56C
Enclosure	TEFC
Degree of Protection	IP69
Service Factor	1.15
Poles	6
Full Load Speed	1155
Insulation Class	F
Temp Rise	80°C
NEMA Code Letter	P
Duty Cycle	S1
Slip	3.75%
NEMA Design	B
Moment of Inertia	0.103 lb.ft.^2
Locked Rotor Time (Hot)	12 seconds
Sound Pressure Level	55 dB(A)
Number of Starts	12
Max Ambient Temperature	40° C
Max Elevation	1000 m.a.s.l (3300 f.a.s.l)
Mounting	F1
Rotation	Bidirectional
Area of Classification	Div.2 Class I, Gr. A,B,C&D T2B
Inverter Rating	10:1 CT/20:1 VT
Standard	NEMA MG1, UL1004
Approvals	CSA,UL,CE

EFFICIENCY/POWER FACTOR

LOAD	EFF	P. F.
100%	81.5 %	0.65
75%	76.0 %	0.58
50%	71.0 %	0.5

TORQUE

FULL LOAD	LRT	BDT
3.3 lb.ft.	255 %	280 %

AMPERAGE INFORMATION

	230V	460V
Full Load Amps	3.7A	1.85
Locked Rotor Amps	25A	12.5A
No Load Current	1.7A	0.85A
Usable at 208V	3.8 A	

BEARING INFORMATION

DE Bearing	6205 2RS
ODE Bearing	6205 2RS
Grease Type	Mobil Polyrex EM
DE Regreasing Interval	-- Hours
ODE Regreasing Interval	-- Hours
Grease Quantity	--

ADDITIONAL DATA

F2 Suitable	No
Shaft Material	304 Stainless Steel
Connection Diagram	9 Lead 2Y/Y
Approximate Weight	35 lbs.

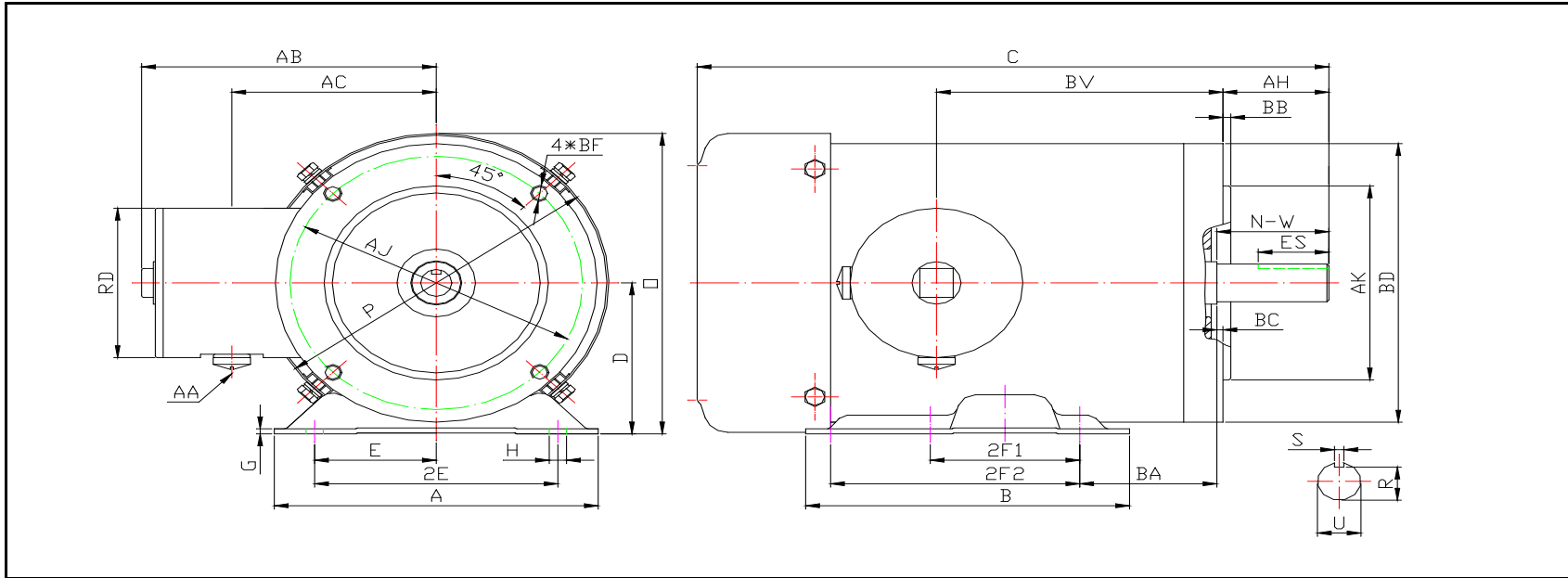

DIMENSION - INCHES

MOUNTING						A	B	C	D	G	P	O	T
E	2E	2F1	2F2	H	BA								
2.44	4.88	3	N/A	1.22*0.34	2.75	6.5	5	12.57	3.5	0.118	6.95	6.98	N/A

AB	BC	KEY		KEYSET	SHAFT			TERMINAL BOX				
		S	ES	R	AH	N-W	U	AA	AB	AC	RD	BV
5.95	-0.19	0.188	1.41	0.517	2.06	1.88	0.625	1/2	5.95	4.5	3.45	5.75

FLANGE				
AJ	AK	BB	BD	BF
5.875	4.5	0.16	6.45	4*3/8-16

REV.	SUMMARY OF MODIFICATIONS	DATE
0		10/21/2020

PERFORMANCE CURVES

Premium Efficiency Motor: **MTSP-P75-3BD12**

Document Generated:	9-Nov-2020	Customer:	
Document ID:			

Motor Type	MTS		
Output Rating (HP)	3/4	FL Speed	1155
Full Load Torque	3.3 lb.ft	LRT (%FLT)	255
		460 volt FLA	1.85
Rotor Wk ²	0.103 lb-ft ²	BDT (%FLT)	280
		230 volt FLA	3.7A

