

DATA SHEET

Premium Efficiency Motor: **MTSP-005-3BD18**

60 Hz

Document Generated: 22-Sep-2021

Document ID:

Customer:

MOTOR INFORMATION

HP	5
RPM	1800
Phase	3
Frequency	60
Voltage	230/460
Frame Size	184TC
Enclosure	TEFC
Degree of Protection	IP69K
Service Factor	1.15
Poles	4
Full Load Speed	1765
Insulation Class	F
Temp Rise	80°C
NEMA Code Letter	J
Duty Cycle	S1
Slip	1.94%
NEMA Design	B
Moment of Inertia	0.5 lb.ft.^2
Locked Rotor Time (Hot)	12 seconds
Sound Pressure Level	64 dB(A)
Number of Starts	12
Max Ambient Temperature	40° C
Max Elevation	1000 m.a.s.l (3300 f.a.s.l)
Mounting	F1
Rotation	Bidirectional
Area of Classification	Div.2 Class I, Gr. A,B,C&D T2B
Inverter Rating	10:1 CT/20:1 VT
Standard	NEMA MG1, UL1004
Approvals	CSA,UL,CE

EFFICIENCY/POWER FACTOR

LOAD	EFF	P. F.
100%	89.5 %	0.85
75%	90.0 %	0.77
50%	89.0 %	0.66

TORQUE

FULL LOAD	LRT	BDT
14.7 lb.ft.	225 %	280 %

AMPERAGE INFORMATION

	230V	460V
Full Load Amps	12.5	6.25
Locked Rotor Amps	92	46
No Load Current	6	3
Usable at 208V	13	

BEARING INFORMATION

DE Bearing	6308 2RS
ODE Bearing	6306 2RS
Grease Type	Mobil Polyrex EM
DE Regreasing Interval	-- Hours
ODE Regreasing Interval	-- Hours
Grease Quantity	--

ADDITIONAL DATA

F2 Suitable	No
Shaft Material	304 Stainless Steel
Connection Diagram	9 Lead 2Y/Y
Approximate Weight	100 lbs.

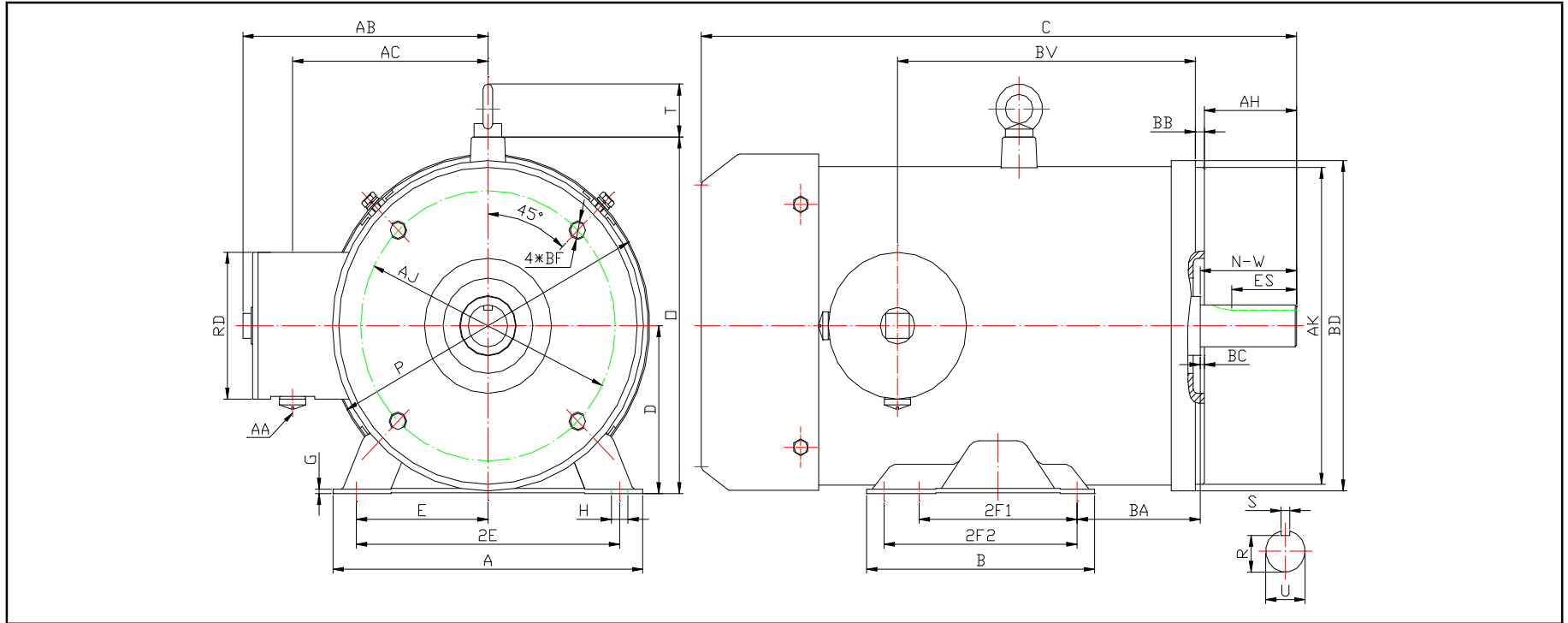

DIMENSIONS - INCHES

MOUNTING					A	B	C	D	G	T	P	O	BC	AB
E	2F1	2F2	H	BA										
3.75	4.5	5.5	0.71*0.47	3.5	8.8	6.5	17.00	4.5	0.118	--	9.25	6.98	0.12	7.00

SHAFT & KEY					
S	ES	R	N-W	U	AH
0.25	1.78	0.986	2.75	1.125	2.62

TERMINAL BOX				
AA	AB	AC	RD	BV
1/2	7	5.55	3.95	8.5

FLANGE				
AK	BD	AJ	BF	BB
8.5	8.85	7.25	(4*)/2-13	0.25

PERFORMANCE CURVES

Premium Efficiency Motor: **MTSP-005-3BD18**

Document Generated: 22-Sep-2021	Customer:
Document ID:	

Motor Type	MTS		FL Speed	1765	
Output Rating (HP)	5		LRT (%FLT)	225	460 volt FLA 6.25
Full Load Torque	14.7	lb.ft	BDT (%FLT)	280	230 volt FLA 12.5
Rotor Wk^2	0.5	lb-ft^2			

SPEED VS TORQUE & CURRENT CURVE

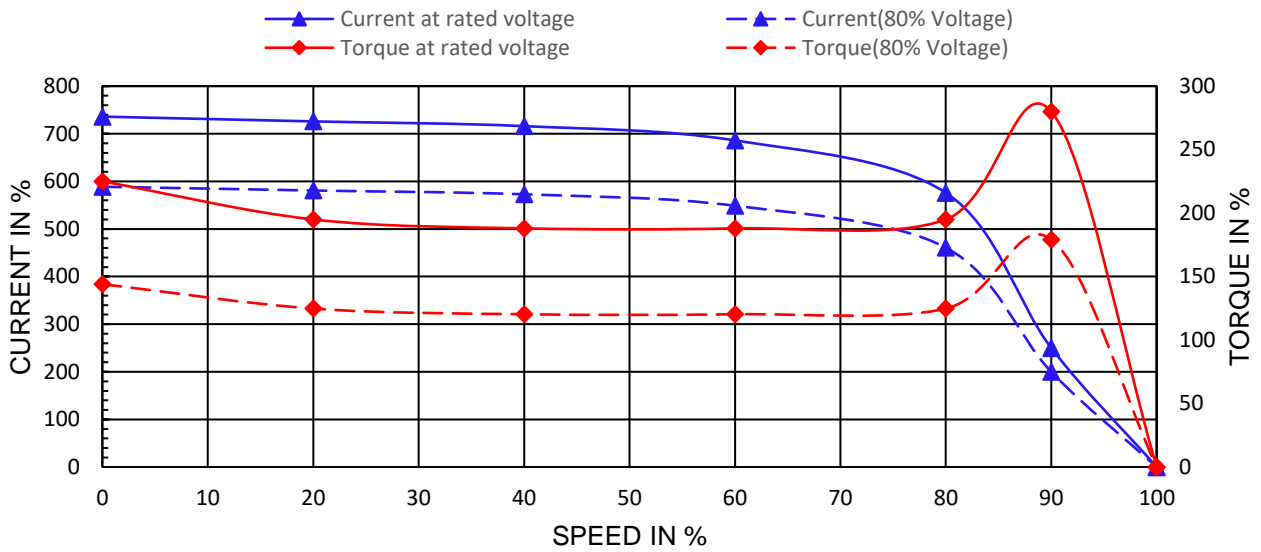

OUTPUT VS EFF., P.F. & CURRENT CURVE

