

ACCESSORIES



CHAPTER

4

TABLE OF CONTENTS

<i>Replacement Parts</i>	4-2
<i>Junction boxes, c-flanges, Drive Bells, and Current Diverter Rings for IronHorse® MTDP Drip-Proof Three-Phase Motors</i>	4-2
<i>Capacitors and Centrifugal Switches for IronHorse® Single-Phase Motors</i>	4-4
<i>Spare/Replacement Parts for MTF2 Single-Phase Farm-Duty Motors</i>	4-4
<i>Spare/Replacement Parts for MTR2/MTRJ Single-Phase Motors</i>	4-6
<i>Spare/Replacement Parts for MTR2/MTRP/MTRJ Three-Phase Motors</i>	4-7
<i>Spare/Replacement Parts for MTCP2 Premium-Efficiency Three-Phase Motors</i>	4-8
<i>C-Flange Kits</i>	4-10
<i>C-Flange Kits for MTCP2 Premium-Efficiency Three-Phase Motors</i>	4-10
<i>STABLE™ Slide Bases</i>	4-12
<i>Slide Base Selection</i>	4-13
<i>Slide Base Dimensions</i>	4-14

REPLACEMENT PARTS

JUNCTION BOXES, C-FLANGES, DRIVE BELLS, AND CURRENT DIVERTER RINGS FOR IRONHORSE® MTDP DRIP-PROOF THREE-PHASE MOTORS

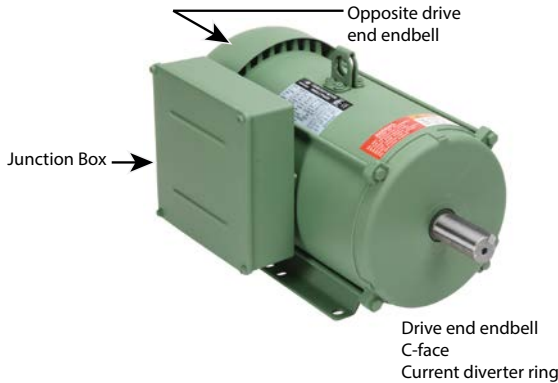

There are a variety of spare / replacement parts for the IronHorse, MTDP, open drip-proof motors. Replacement junction boxes, c-face kits, drive end and opposite drive end bells are available for all frame sizes. "CDR" current diverter rings are also available for use with these motors.

MTDP Three-Phase Motor Spare/Replacement Parts			
Part Number	Accessory Type	For Use With	Motor HP
MTADP-JBOX-140	Junction Box	56 and 140T frame ODP motors	1, 1.5, 2, 3 HP
MTADP-JBOX-180		180T frame ODP motors	3, 5, 7.5HP
MTADP-JBOX-210		210T frame ODP motors	7.5, 10HP
MTADP-JBOX-250		250T frame ODP motors	15, 20HP
MTADP-JBOX-280		280T frame ODP motors	25, 30HP
MTADP-JBOX-320		320T frame ODP motors	40, 50HP
MTADP-CFACE-140TC	C-face	140T frame ODP motors	1, 1.5, 2 HP
MTADP-CFACE-180TC		180T frame ODP motors	3, 5
MTADP-CFACE-210TC		210T frame ODP motors	7.5, 10
MTADP-CFACE-250TC		250T frame ODP motors	15, 20
MTADP-CFACE-280TC		280T frame ODP motors	25, 30
MTADP-CFACE-320TC		320T frame ODP motors	40, 50
MTADP-DEB-140	Drive end endbell	140T frame ODP motors	1, 1.5, 2 HP
MTADP-DEB-180		180T frame ODP motors	3, 5
MTADP-DEB-210		210T frame ODP motors	7.5, 10
MTADP-DEB-250		250T frame ODP motors	15, 20
MTADP-DEB-280		280T frame ODP motors	25, 30
MTADP-DEB-320		320T frame ODP motors	40, 50
MTADP-OEB-140	Opposite drive end endbell	140T frame ODP motors	1, 1.5, 2 HP
MTADP-OEB-180		180T frame ODP motors	3, 5
MTADP-OEB-210		210T frame ODP motors	7.5, 10
MTADP-OEB-250		250T frame ODP motors	15, 20
MTADP-OEB-280		280T frame ODP motors	25, 30
MTADP-OEB-320		320T frame ODP motors	40, 50
*** TABLE CONTINUED NEXT PAGE ***			

*** TABLE CONTINUED FROM PREVIOUS PAGE ***

MTDP Three-Phase Motor Spare/Replacement Parts			
Part Number	Accessory Type	For Use With	Motor HP
MTADP-CDR-140	Current diverter ring	140T frame ODP motors	1, 1.5, 2
MTADP-CDR-180		180T frame ODP motors	3, 5
MTADP-CDR-210		210T frame ODP motors	7.5, 10
MTADP-CDR-250		250T frame ODP motors	15, 20
MTADP-CDR-280		280T frame ODP motors	25, 30
MTADP-CDR-320		320T frame ODP motors	40, 50



Current Diverter Ring

CAPACITORS AND CENTRIFUGAL SWITCHES FOR IRONHORSE® SINGLE-PHASE MOTORS

Single-phase motors use capacitors to provide starting torque when power is first applied to the motor. When the motor begins to turn, the start capacitor is no longer needed and is taken out of the circuit by a centrifugal switch. In addition to the start capacitor, 1-1/2 hp and larger IronHorse single-phase motors have run capacitors to allow the motor to develop higher running torque and greater efficiency. Run capacitors also help improve the motor power factor.

MTF2 ACCESSORY LOCATIONS

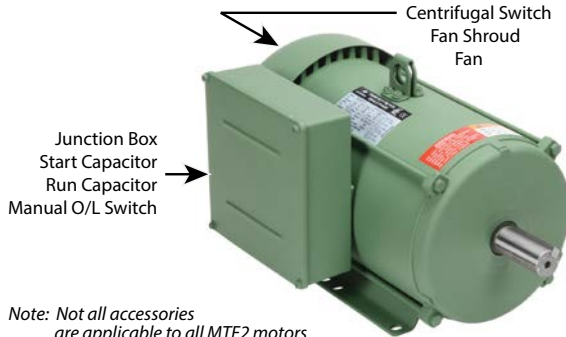

Note: Not all accessories are applicable to all MTF2 motors

MTR2/MTRJ ACCESSORY LOCATIONS

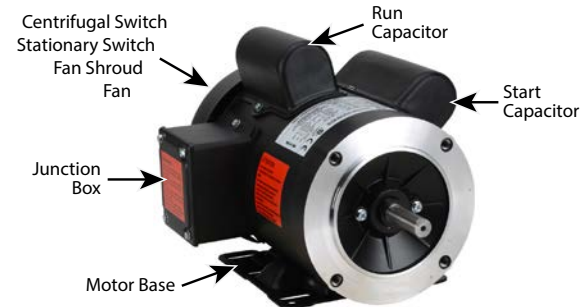

Note: Not all accessories are applicable to all MTR and MTR2 motors

SPARE/REPLACEMENT PARTS FOR MTF2 SINGLE-PHASE FARM-DUTY MOTORS

MTF2 Single-Phase Motor Spare/Replacement Parts						
Part Number	Accessory Type	Capacitance (µF)	Rated Voltage	Dimension Height x Ø (in[mm])	Applicable Motor Number	Motor HP
MTAF2-CAP-16	Start capacitor	250	300	3.39 x 1.81 [86.1 x 46.0]	MTF2-002-1B18-182, MTF2-003-1B18	2, 3
MTAF2-CAP-17		550		3.39 x 1.81 [86.1 x 46.0]	MTF2-005-1B18	5
MTAF2-CAP-18		400	330	4.33 x 1.97 [110.0 x 50.0]	MTF2-7P5-1B18	7.5
MTAF2-CAP-19	Run capacitor	550	330	3.96 x 1.77 [100.6 x 45.0]	MTF2-010-1B18-182	10
MTAF2-CAP-20		25	450	3.96 x 1.97 [100.6 x 50.0]	MTF2-002-1B18	2
MTAF2-CAP-21		30	450	4.17 x 1.97 [106.0 x 50.0]	MTF2-003-1B18	3
MTAF2-CAP-22		50	450	3.54 x 2.00 [90 x 51]	MTF2-005-1B18	5
MTAF2-CAP-23		45	500	4.25 x 2.12 [105 x 54]	MTF2-7P5-1B18-215	7.5
MTAF2-CAP-24		60	500	4.72 x 1.95 [120 x 50]	MTF2-010-1B18	10
MTAF2-CSW-05		Centrifugal switch	n/a	n/a	n/a	MTF2-002-1B18-182, MTF2-003-1B18, MTF2-005-1B18
MTAF2-CSW-06	250					MTF2-7P5-1B18-215
MTAF2-SSW-05	Stationary Switch	n/a	n/a	n/a	MTF2-002-1B18-182, MTF2-003-1B18, MTF2-005-1B18	2,3, 5
MTAF2-SSW-06					n/a	MTF2-7P5-1B18-215, MTF2-010-1B18
MTAF2-MOL-1	Manual overload switch	n/a	n/a	n/a	MTF2-002-1B18-182	2
MTAF2-MOL-2					MTF2-003-1B18	3
MTAF2-MOL-3					MTF2-005-1B18	5
MTAF2-MOL-4					MTF2-7P5-1B18-215	7.5
MTAF2-MOL-5					MTF2-010-1B18	10

*** TABLE CONTINUED NEXT PAGE ***

*** TABLE CONTINUED FROM PREVIOUS PAGE ***

MTF2 Single-Phase Motor Spare/Replacement Parts						
Part Number	Accessory Type	Capacitance (μF)	Rated Voltage	Dimension Height x Ø (in[mm])	Applicable Motor Number	Motor HP
MTF2-CFACE-180TC	C-face kit	n/a	n/a	n/a	MTF2-002-1B18-182 MTF2-003-1B18 MTF2-005-1B18	2, 3, 5
MTF2-CFACE-210TC		n/a	n/a	n/a	MTF2-7P5-1B18-215 MTF2-010-1B18	7.5, 10
MTAF2-JBOX-180	Junction box	n/a	n/a	n/a	MTF2-002-1B18-182 MTF2-003-1B18 MTF2-005-1B18	2, 3, 5
MTAF2-JBOX-210		n/a	n/a	n/a	MTF2-7P5-1B18-215 MTF2-010-1B18	7.5, 10
MTAF2-FAN-180	Fan		n/a	n/a	MTF2-002-1B18-182 MTF2-003-1B18 MTF2-005-1B18	2, 3, 5
MTAF2-FAN-210			n/a	n/a	MTF2-7P5-1B18-215 MTF2-010-1B18	7.5, 10
MTAF2-SHROUD-180	Fan shroud		n/a	n/a	MTF2-002-1B18-182 MTF2-003-1B18 MTF2-005-1B18	2, 3, 5
MTAF2-SHROUD-210			n/a	n/a	MTF2-7P5-1B18-215 MTF2-010-1B18	7.5, 10

MTF2 Single-Phase Motor Spare/Replacement Parts						
ADC Part Number	Manufacturer Part Number	Temperature Rating - Deg C		Current	Short Time Rating	
		Open +/-5	Closed +/-9		Min (Sec)	Max (Sec)
MTAF2-MOL-1	BEH-70KB 79A 60/230V KWE	120	74	59	6.5	16
MTAF2-MOL-2	BEH-42KB 89A 60/230V KWE	120	74	70.6	6.5	16
MTAF2-MOL-3	LEH-31JD 171A 60/230V KWE	135	96	129	6.5	16
MTAF2-MOL-4	LEH-28KD 238A 60/230V KWE	135	96	190	11	20.5
MTAF2-MOL-5	LEH-00BB 366A 60/230V KWE	120	74	203	10	21.5

CAPACITORS AND CENTRIFUGAL SWITCHES FOR IRONHORSE SINGLE-PHASE MOTORS (CONTINUED)

SPARE/REPLACEMENT PARTS FOR MTR2/MTRJ SINGLE-PHASE MOTORS

MTR2/MTRJ Single-Phase Motor Spare/Replacement Parts (NOT for MTR Motors)*							
Part Number	Accessory Type	Capacitance (μF)	Rated Voltage	Dimension Height x Ø (in [mm])	Applicable MTR2 Motor Number	MTR2 Motor HP ; RPM	
MTA-CAP-10	Start Capacitor	200	165	2.80 x 1.46 [71.1 x 37.1]	MTR2-P33-1AB36 MTRJ-001-1AB36J	1/3 : 3600 1 : 3600	
MTA-CAP-11	Start Capacitor	300		3.39 x 1.85 [86.1 x 47.0]	MTR2-P33-1AB18 MTR2-P50-1AB36 MTRJ-1P5-1AB36J	1/3: 1800 1/2 : 3600 1 1/2 : 3600	
MTA-CAP-12	Start Capacitor	400			MTR2-P50-1AB18 MTR2-P75-1AB36 MTRJ-002-1AB36J	1/2: 1800 3/4 : 3600 2 : 3600	
MTA-CAP-13	Start Capacitor	500			MTR2-P75-1AB18 MTR2-001-1AB18 MTR2-001-1AB36	3/4: 1800 1: 1800 1 : 3600	
MTA-CAP-14	Run Capacitor	40	250	3.38 x 1.81 [85.9 x 46.0]	MTR2-1P5-1ABxx MTR2-002-1ABxx MTRJ-1P5-1AB36J MTRJ-002-1AB36J	1 1/2 : all 2 : all 1 1/2 : 3600 2 : 3600	
MTA-CAP-15	Start Capacitor	800	165	4.41 x 1.85 [112.0 x 47.0]	MTR2-1P5-1AB18	1-1/2 : 1800	
MTA-CAP-22	Start Capacitor	900	165	4.375 x 1.8125 [111.1 x 46.0]	MTR2-1P5-1AB18	1-1/2 : 1800	
MTA-CAP-31	Start Capacitor	150	165	3.39 x 1.85 [86.1 x 47.0]	MTRJ-P33-1AB36J MTRJ-P50-1AB36J MTRJ-P75-1AB36J	1/3 : 3600 1/2 : 3600 3/4 : 3600	
MTA-CSW-03	Centrifugal Switch	n/a	125	n/a	MTR2-xxx-1AB36	all 3600 rpm	
MTA-CSW-04	Stationary Switch				MTR2-xxx-1ABxx	all	
MTA-CSW-08	Centrifugal Switch				MTR2-xxx-1AB18	all 1800 rpm	
MTA2-BASE-56	Motor Base		n/a		n/a	MTR2-xxx-1ABxx MTRJ-xxx-1ABxx	all
MTA2-FAN-56	Fan						
MTA2-JBOX-56	Junction Box						
MTA2-SHROUD-56	Fan Shroud						

* These accessories are spare/replacement components only for MTR2 series IronHorse motors.
Accessories for MTR2 series motors are NOT compatible with MTR series motors.

SPARE/REPLACEMENT PARTS FOR MTR2/MTRP/MTRJ THREE-PHASE MOTORS

IronHorse bases, fans, and fan shrouds are available as direct replacement parts for MTR2, and MTRP motors.

These parts are field installable, and include installation instructions.



Fan



Fan Shroud



Junction Box



Motor Base



Fan

MTR2/MTRP/MTRJ Series Three-Phase Motor Spare/ Replacement Part*			
Part Number	Description	Applicable MTRP Motor Number	MTR2/MTRP Motor HP : RPM
MTA2-BASE-56	Motor base	MTRP-xxx-3BDxx MTR2-Pxx-3BDxx MTRJ-Xxx-3BDxx	All
MTA2-JBOX-56	Junction box		
MTA2-SHROUD-56	Fan shroud		
MTA2-FAN-56	Fan	MTR2-Pxx-3BDxx MTRJ-Xxx-3BDxx	
MTA2-FAN-56-1	Fan	MTRP-xxx-3BDxx MTRJP-Xxx-3BDxx	

* These accessories are spare/replacement components only for MTR2/ MTRP series IronHorse motors.

SPARE/REPLACEMENT PARTS FOR MTCP2 PREMIUM-EFFICIENCY THREE-PHASE MOTORS

IronHorse junction boxes, TEFC fans, and TEFC fan shrouds are available as direct replacement parts for MTCP2 motors.

These parts are field installable, and include installation instructions.



Fan



Fan Shroud



Junction Box

MTCP2 Premium-Efficiency Three-Phase Motor Replacement Parts					
Part Number (1)	Description (2)(3)(4)	Fits Frame	Fits PE Motor Number (1)	Motor HP	Product Weight (lb)
MTAP2-FAN-140	Replacement Fan	143 & 145	MTCP2-001-3BD12	1	0.029
MTAP2-SHROUD-140	Replacement Fan Shroud		MTCP2-001-3BD18(C)	1	1.04
MTAP2-JBOX-140	Replacement Junction Box		MTCP2-1P5-3BD18(C)	1-1/2	
		MTCP2-1P5-3BD36	1-1/2	2.54	
MTAP2-FAN-180	Replacement Fan	182 & 184	MTCP2-002-3BD18(C)		2
	MTAP2-SHROUD-180		Replacement Fan Shroud	MTCP2-002-3BD12	2
MTAP2-JBOX-180	Replacement Junction Box		MTCP2-003-3BD18(C)	3	2.23
		MTCP2-003-3BD36	3	3.28	
MTAP2-FAN-210-2	Replacement Fan (for 2-pole motors)	213 & 215	MTCP2-005-3BD18(C)		5
	MTAP2-FAN-210		Replacement Fan (4&6-pole)	MTCP2-7P5-3BD36	7-1/2
MTAP2-SHROUD-210	Replacement Fan Shroud		MTCP2-010-3BD36	10	10
MTAP2-JBOX-210	Replacement Junction Box		MTCP2-003-3BD12	3	3.28
			MTCP2-005-3BD12	5	
			MTCP2-7P5-3BD18(C)	7-1/2	
			MTCP2-010-3BD18(C)	10	

1) These MTAP2 replacement components fit only MTCP2 Premium-Efficiency motors; they will NOT fit MTC EPart motors.
 2) Replacement fans include fan, snap ring, and instructions.
 3) Replacement fan shrouds include shroud, bolts w/washers, rubber plug, and instructions.
 4) Replacement junction boxes include gasketed base & cover assembly, base gasket, base bolts, and instructions.

*** TABLE CONTINUED NEXT PAGE ***

SPARE/REPLACEMENT PARTS FOR MTCP2 PREMIUM-EFFICIENCY 3-PHASE MOTORS (CONTINUED)

*** TABLE CONTINUED FROM PREVIOUS PAGE ***					
MTCP2 Premium-Efficiency Three-Phase Motor Replacement Parts					
Part Number (1)	Description (2)(3)(4)	Fits Frame	Fits PE Motor Number (1)	Motor HP	Product Weight (lb)
MTAP2-FAN-250-2	Replacement Fan (for 2-pole motors)	254 & 256	MTCP2-015-3BD36 MTCP2-020-3BD36	15 20	0.090
MTAP2-FAN-250	Replacement Fan (4&6-pole)		MTCP2-7P5-3BD12	7-1/2	0.104
MTAP2-SHROUD-250	Replacement Fan Shroud		MTCP2-010-3BD12	10	8.27
MTAP2-JBOX-250	Replacement Junction Box		MTCP2-015-3BD18(C) MTCP2-020-3BD18(C)	15 20	8.16
MTAP2-FAN-280	Replacement Fan	284 & 286	MTCP2-015-3BD12	15	0.090
MTAP2-SHROUD-280	Replacement Fan Shroud		MTCP2-020-3BD12	20	10.03
MTAP2-JBOX-280	Replacement Junction Box		MTCP2-025-3BD18(C) MTCP2-030-3BD18(C)	25 30	8.16
MTAP2-FAN-320	Replacement Fan	324 & 326	MTCP2-040-3BD18	40	0.126
MTAP2-SHROUD-320	Replacement Fan Shroud		MTCP2-050-3BD18	50	12.50
MTAP2-JBOX-320	Replacement Junction Box				23.59
MTAP2-FAN-360	Replacement Fan	364 & 365	MTCP2-060-3BD18	60	0.126
MTAP2-SHROUD-360	Replacement Fan Shroud		MTCP2-075-3BD18	75	13.76
MTAP2-JBOX-360	Replacement Junction Box				21.05
MTAP2-FAN-400	Replacement Fan	405	MTCP2-100-3BD18	100	0.150
MTAP2-SHROUD-400	Replacement Fan Shroud				16.67
MTAP2-JBOX-400	Replacement Junction Box				32.74
MTAP2-FAN-440	Replacement Fan	444 & 445 & 447	MTCP2-125-3BD18	125	0.150
MTAP2-SHROUD-440	Replacement Fan Shroud		MTCP2-150-3BD18	150	17.97
MTAP2-JBOX-440	Replacement Junction Box		MTCP2-200-3BD18	200	36.49
MTAP2-FAN-449	Replacement Fan (250hp)	449	MTCP2-250-3D18	250	0.205
MTAP2-FAN-449-1	Replacement Fan (300hp)		MTCP2-300-3D18	300	0.174
MTAP2-SHROUD-449	Replacement Fan Shroud				22.27
MTAP2-JBOX-449	Replacement Junction Box				36.49

1) These MTAP2 replacement components fit only MTCP2 Premium-Efficiency motors; they will NOT fit MTC EPart motors.
 2) Replacement fans include fan, snap ring, and instructions.
 3) Replacement fan shrouds include shroud, bolts w/washers, rubber plug, and instructions.
 4) Replacement junction boxes include gasketed base & cover assembly, base gasket, base bolts, and instructions.

C-FLANGE KITS

C-FLANGE KITS FOR MTCP2 PREMIUM-EFFICIENCY THREE-PHASE MOTORS

C-FLANGE KITS

Any IronHorse MTCP2 Premium-Efficiency T-frame cast-iron motor from 1–300 hp can be converted to C-face mounting by using a cast iron C-flange kit. These kits are field installable and include the C-faces and mounting bolts.



MTAP2 T-Frame C-Flange Kit

C-FLANGE DIMENSIONS

C-flange dimensions are shown in Chapter 2 (Mounting & Initial Startup) along with TC-frame motor dimensions.



Authorized EASA service centers are equipped with the necessary equipment to quickly and inexpensively install C-Face kits. Visit the EASA website at www.easa.com to find the nearest authorized service center.

C-faces must be installed by an EASA motor shop in order to maintain the motor warranty.

MTCP2 Premium-Efficiency T-frame Three-Phase Motor C-Flange Kits				
Part Number (1)	Fits Frame	Fits Motor (1)	Motor HP	Product Weight (lb)
MTAP2-CFACE-140TC	143T & 145T	MTCP2-001-3BD12	1	5.62
		MTCP2-001-3BD18	1	
		MTCP2-1P5-3BD18	1-1/2	
		MTCP2-1P5-3BD36	1-1/2	
		MTCP2-002-3BD18	2	
		MTCP2-002-3BD36	2	
MTAP2-CFACE-180TC	182T & 184T	MTCP2-1P5-3BD12	1-1/2	10.36
		MTCP2-002-3BD12	2	
		MTCP2-003-3BD18	3	
		MTCP2-003-3BD36	3	
		MTCP2-005-3BD18	5	
		MTCP2-005-3BD36	5	
MTAP2-CFACE-210TC	213T & 215T	MTCP2-003-3BD12	3	12.68
		MTCP2-005-3BD12	5	
		MTCP2-7P5-3BD18	7-1/2	
		MTCP2-7P5-3BD36	7-1/2	
		MTCP2-010-3BD18	10	
		MTCP2-010-3BD36	10	
MTAP2-CFACE-250TC	254T & 256T	MTCP2-7P5-3BD12	7-1/2	31.20
		MTCP2-010-3BD12	10	
		MTCP2-015-3BD18	15	
		MTCP2-015-3BD36	15	
		MTCP2-020-3BD18	20	
		MTCP2-020-3BD36	20	
1) MTAP2-CFACE C-flange kits will NOT fit MTC EPAAct motors.				
*** TABLE CONTINUED NEXT PAGE ***				

C-FLANGE KITS FOR MTCP2 PREMIUM-EFFICIENCY THREE-PHASE MOTORS (CONTINUED)

*** TABLE CONTINUED FROM PREVIOUS PAGE ***				
MTCP2 Premium-Efficiency T-frame Three-Phase Motor C-Flange Kits				
Part Number (1)	Fits Frame	Fits Motor (1)	Motor HP	Product Weight (lb)
MTAP2-CFACE-280TC	284T & 286T	MTCP2-015-3BD12 MTCP2-020-3BD12 MTCP2-025-3BD18 MTCP2-030-3BD18	15 20 25 30	31.20
MTAP2-CFACE-320TC	324T & 326T	MTCP2-040-3BD18 MTCP2-050-3BD18	40 50	47.40
MTAP2-CFACE-360TC	364T & 365T	MTCP2-060-3BD18 MTCP2-075-3BD18	60 75	48.70
MTAP2-CFACE-400TC	405T	MTCP2-100-3BD18	100	132.17
MTAP2-CFACE-444TC	444T & 445T	MTCP2-125-3BD18 MTCP2-150-3BD18	125 150	137.44
MTAP2-CFACE-447TC	445/7T	MTCP2-200-3BD18	200	134.83
MTAP2-CFACE-449TC	449T	MTCP2-250-3D18 MTCP2-300-3D18	250 300	162.50
1) MTAP2-CFACE C-flange kits will NOT fit MTC EPAct motors.				

STABLE™ SLIDE BASES

AutomationDirect offers STABLE AC motor adjustable slide bases for mounting most AC motor brands with frame sizes from 56 to 449. These heavy duty steel bases are primed with an oven-baked primer ready for painting. The motor mounting bolts are welded to the exact motor foot pattern to prevent the bolts from spinning.



SLIDE BASE SELECTION

STABLE™ Motor Slide Bases			
Part Number	Fits Frame Type	Product Weight (lb)	IronHorse Model
MTA-BASE-W56*	56C*	2.8	MTR2-xxx-xxxxx*, MTRP-xxx-xxxxx
MTA-BASE-W143T	143T/TC	4.6	MTCP2-001-3BD18(C)(CK), MTCP2-1P5-3BD36 MTDP-001-3BD18
MTA-BASE-W145T	145T/TC	5.1	MTCP2-001-3BD12 MTCP2-1P5-3BD18(C)(CK) MTCP2-002-3BD18(C)(CK) MTCP2-002-3BD36, MTDP-1P5-3BD18 MTDP-002-3BD18, MTDP-003-3BD36
MTA-BASE-W182T	182T/TC	9.2	MTCP2-1P5-3BD12 MTCP2-003-3BD18(C)(CK) MTCP2-003-3BD36, MTF-002-1C18-182 MTF2-002-1B18-182, MTDP-003-3BD18 MTDP-005-3BD36, MTF2-002-1B18-182
MTA-BASE-W184T	184T/TC	10	MTCP2-002-3BD12 MTCP2-005-3BD18(C)(CK) MTCP2-005-3BD36 MTF-00x-1C18, MTF2-002-1B18-182 MTDP-005-3BD18, MTDP-7P5-3BD36 MTF2-003-1B18, MTF2-005-1B18
MTA-BASE-W213T	213T/TC	13	MTCP2-003-3BD12 MTCP2-7P5-3BD18(C)(CK) MTCP2-7P5-3BD36 MTDP-7P5-3BD18
MTA-BASE-W215T	215T/TC	15	MTCP2-005-3BD12 MTCP2-010-3BD18(C)(CK) MTCP2-010-3BD36 MTF2-010-1818, MTDP-010-3BD18 MTF2-7P5-1B18-215, MTF-010-1B18
MTA-BASE-W254T	254T/TC	18	MTCP2-7P5-3BD12 MTCP2-015-3BD18(C)(CK) MTCP2-015-3BD36, MTDP-015-3BD18
MTA-BASE-W256T	256T/TC	19	MTCP2-010-3BD12 MTCP2-020-3BD18(C)(CK) MTCP2-020-3BD36, MTDP-020-3BD18
MTA-BASE-W284T	284T/TC	20	MTCP2-015-3BD12 MTCP2-025-3BD18(C)(CK) MTDP-025-3BD18
MTA-BASE-W286T	286T/TC	21	MTCP2-020-3BD12 MTCP2-030-3BD18(C)(CK) MTDP-030-3BD18
MTA-BASE-W324T	324T/TC	30	MTCP2-040-3BD18(C)(CK), MTDP-040-3BD18
MTA-BASE-W326T	326T/TC	31	MTCP2-050-3BD18(C)(CK), MTDP-050-3BD18
MTA-BASE-W364T	364T/TC	43	MTCP2-060-3BD18(C)(CK)
MTA-BASE-W365T	365T/TC	43	MTCP2-075-3BD18(C)(CK)
MTA-BASE-W404T	404T/TC	58	-
MTA-BASE-W405T	405T/TC	60	MTCP2-100-3BD18(C)(CK)
MTA-BASE-W444T	444T	63	MTCP2-125-3BD18
MTA-BASE-W445T	445T	65	MTCP2-150-3BD18
MTA-BASE-W447T	447T	89	MTCP2-200-3BD18
MTA-BASE-W449T	449T	94	MTCP2-250-3D18 MTCP2-300-3D18

* IronHorse MTR2 and MTRP 56HC motors have double-punched bases to mount on slide base MTA-BASE-W56

SLIDE BASE DIMENSIONS

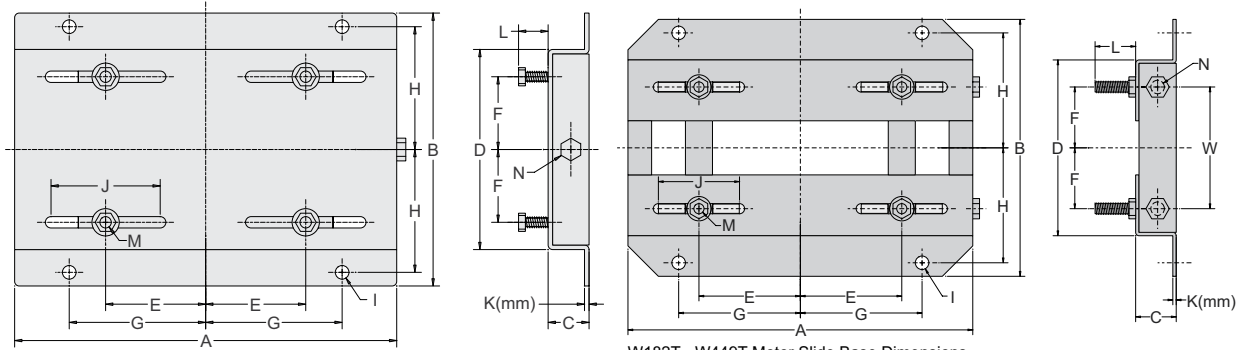

W56 - W145T Motor Slide Base Dimensions

W182T - W449T Motor Slide Base Dimensions
(W182T-W215T bases have one-piece top plates, similar to W56-W145T)

Dimensions [inches, except as noted] - STABLE™ Motor Slide Bases							
MTA-BASE-Wxxxx	A	B	C	D	E	F	G
56	10-5/8	6-1/2	1-1/8	4-1/2	2-7/16	1-1/2	3-13/16
143T	10-1/2	7-1/2	1-1/8	5-1/2	2-3/4	2	3-3/4
145T	10-1/2	8-1/2	1-1/8	6-1/2	2-3/4	2-1/2	3-3/4
182T	12-3/4	9-1/2	1-1/2	6-1/2	3-3/4	2-1/4	4-1/2
184T	12-3/4	10-1/2	1-1/2	7-1/2	3-3/4	2-3/4	4-1/2
213T	15	11	1-3/4	7-1/2	4-1/4	2-3/4	5-1/4
215T	15	12-1/2	1-3/4	9	4-1/4	3-1/2	5-1/4
254T	17-3/4	15-1/8	2	10-3/4	5	4-1/8	6-1/4
256T	17-3/4	16-7/8	2	12-1/2	5	5	6-1/4
284T	19-3/4	16-7/8	2	12-1/2	5-1/2	4-3/4	7
286T	19-3/4	18-3/8	2	14	5-1/2	5-1/2	7
324T	22-3/4	19-1/4	2-1/2	14	6-1/4	5-1/4	8
326T	22-3/4	20-3/4	2-1/2	15-1/2	6-1/4	6	8
364T	25-1/2	20-1/2	2-1/2	15-1/2	7	5-5/8	9
365T	25-1/2	21-1/2	2-1/2	16-1/2	7	6-1/8	9
404T	28-3/4	22-3/8	3	16-1/2	8	6-1/8	10
405T	28-3/4	23-7/8	3	18	8	6-7/8	10
444T	31-1/4	24-5/8	3	19-1/4	9	7-1/4	11
445T	31-1/4	26-5/8	3	21-1/4	9	8-1/4	11
447T	31-1/4	30-1/8	3	24-3/4	9	10	11
449T	31-1/4	35-1/8	3	29-3/4	9	12-1/2	11

**** Table Continued Next Page for Dimensions H-W ****

SLIDE BASE DIMENSIONS (CONTINUED)

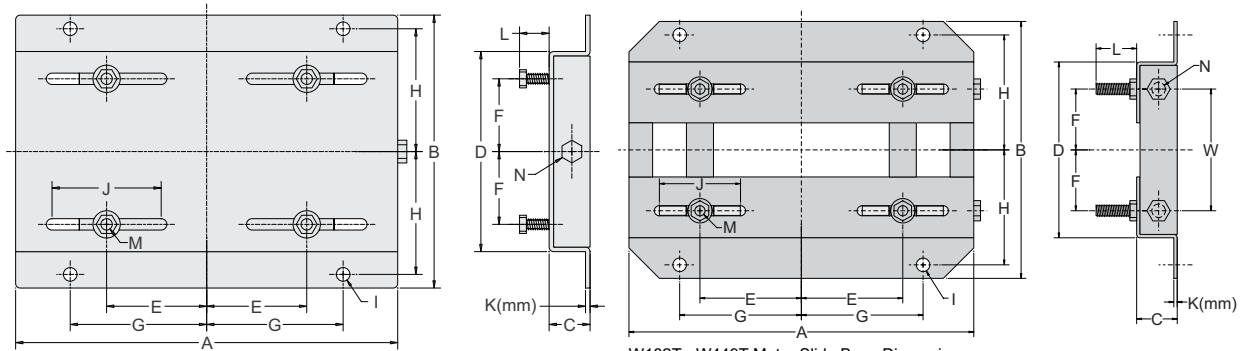

W56 - W145T Motor Slide Base Dimensions

W182T - W449T Motor Slide Base Dimensions
(W182T-W215T bases have one-piece top plates, similar to W56-W145T)

**** Table Continued from Previous Page for Dimensions A-G ****

Dimensions [inches, except as noted] - STABLE™ Motor Slide Bases (continued)								
MTA-BASE-Wxxxx	H	I	J	K(mm)	L	M	N	W
56	2-7/8	3/8	3	2 mm	7/8	5/16 x 1	3/8 x 4	n/a
143T	3-3/8	3/8	3	3 mm	13/16	5/16 x 1	3/8 x 4	n/a
145T	3-7/8	3/8	3	3 mm	13/16	5/16 x 1	3/8 x 4	n/a
182T	4-1/4	1/2	3	3.5 mm	1-1/2	3/8 x 1-3/4	1/2 x 6	4-1/2
184T	4-3/4	1/2	3	3.5 mm	1-1/2	3/8 x 1-3/4	1/2 x 6	5-1/2
213T	4-3/4	1/2	3-1/2	3.8 mm	1-1/2	3/8 x 1-3/4	1/2 x 6	5-1/2
215T	5-1/2	1/2	3-1/2	3.8 mm	1-1/2	3/8 x 1-3/4	1/2 x 6	7
254T	6-5/8	5/8	4	4.6 mm	1-7/16	1/2 x 1-3/4	5/8 x 6	5-5/16
256T	7-1/2	5/8	4	4.6 mm	1-7/16	1/2 x 1-3/4	5/8 x 6	7
284T	7-1/2	5/8	4-1/2	4.6 mm	1-11/16	1/2 x 2	5/8 x 6	7
286T	8-1/4	5/8	4-1/2	4.6 mm	1-11/16	1/2 x 2	5/8 x 6	8
324T	8-1/2	3/4	5-1/4	4.6 mm	2-3/16	5/8 x 2-1/2	3/4 x 9	7
326T	9-1/4	3/4	5-1/4	4.6 mm	2-3/16	5/8 x 2-1/2	3/4 x 9	8-1/2
364T	9-1/8	3/4	6	5.8 mm	2-1/16	5/8 x 2-1/2	3/4 x 9	7-3/4
365T	9-5/8	3/4	6	5.8 mm	2-1/16	5/8 x 2-1/2	3/4 x 9	8-3/4
404T	9-7/8	7/8	7	5.8 mm	2-1/2	3/4 x 3	3/4 x 11	8-3/4
405T	10-5/8	7/8	7	5.8 mm	2-1/2	3/4 x 3	3/4 x 11	10-1/4
444T	11	7/8	7-1/2	5.8 mm	2-1/2	3/4 x 3	3/4 x 11	11
445T	12	7/8	7-1/2	5.8 mm	2-1/2	3/4 x 3	3/4 x 11	13
447T	13-3/4	7/8	7-1/2	8 mm	3	3/4 x 3-1/2	3/4 x 11	16-1/2
449T	16-1/4	7/8	7-1/2	8 mm	3	3/4 x 3-1/2	3/4 x 11	21-1/2

Blank
PAGE