

GETTING STARTED



TABLE OF CONTENTS

<i>Manual Overview</i>	1-2
<i>Overview of this Publication</i>	1-2
<i>Who Should Read This Manual</i>	1-2
<i>Technical Support</i>	1-2
<i>Special Symbols</i>	1-2
<i>Receiving and Inspection.</i>	1-2
<i>Unpacking.</i>	1-2
<i>Available Models</i>	1-3
<i>IronHorse Motors Part Number Information</i>	1-3
<i>Permanent Magnet DC Motors Features and Specifications</i>	1-3
<i>Reshipping</i>	1-6
<i>Long Term Storage</i>	1-6
<i>Warranty</i>	1-6

MANUAL OVERVIEW

OVERVIEW OF THIS PUBLICATION

The IronHorse General Purpose DC Motor User Manual describes the installation, maintenance and use of all IronHorse General Purpose DC Motors.

WHO SHOULD READ THIS MANUAL

This manual contains important information for those who will install, maintain, use and/or resell any of the IronHorse motors.

TECHNICAL SUPPORT

By Telephone: **770-844-4200**
(Mon.-Fri., 9:00 a.m.-6:00 p.m. E.T.)

On the Web: **support.automationdirect.com**

Our technical support group is glad to work with you in answering your questions. If you cannot find the solution to your particular application, or, if for any reason you need additional technical assistance, please call technical support at **770-844-4200**. We are available weekdays from 9:00 a.m. to 6:00 p.m. Eastern Time.

We also encourage you to visit our web site where you can find technical and non-technical information about our products and our company. Visit us at **www.automationdirect.com**.

SPECIAL SYMBOLS



WHEN YOU SEE THE "NOTEPAD" ICON IN THE LEFT-HAND MARGIN, THE PARAGRAPH TO ITS IMMEDIATE RIGHT WILL BE A SPECIAL NOTE.



WHEN YOU SEE THE "EXCLAMATION MARK" ICON IN THE LEFT-HAND MARGIN, THE PARAGRAPH TO ITS IMMEDIATE RIGHT WILL BE A WARNING. THIS INFORMATION COULD PREVENT INJURY, LOSS OF PROPERTY, OR EVEN DEATH (IN EXTREME CASES).

RECEIVING AND INSPECTION

UNPACKING

After receiving an IronHorse motor, please check for the following:

- Open the motor packaging and inspect for damage during shipment.
- Make sure the part number indicated on the motor nameplate corresponds with the part number on your order.
- For all 56C-frame motors, make sure that the shipment contains the motor, with attached removable mounting foot and two spare brushes.

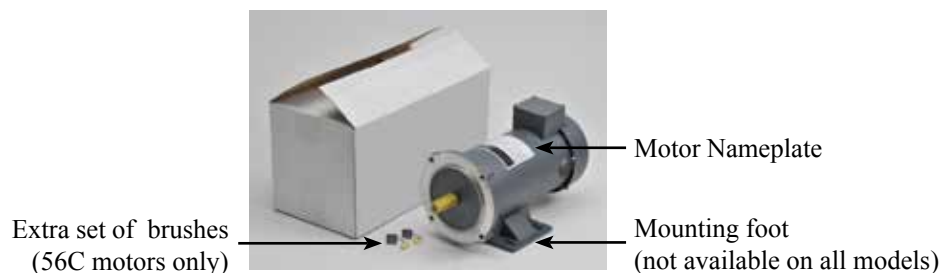

AVAILABLE MODELS

IRONHORSE MOTORS PART NUMBER INFORMATION

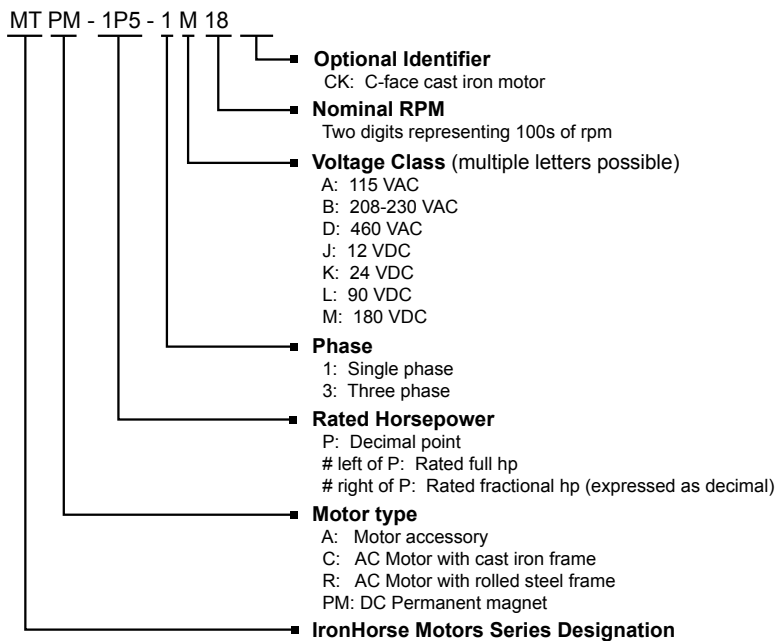

PERMANENT MAGNET DC MOTORS FEATURES AND SPECIFICATIONS

SMALL-FRAME PERMANENT MAGNET DC (PMDC) MOTORS

IronHorse small-frame PMDC motors are available from 1/31 hp to 1/4 hp. All models have a TENV rolled steel frame. Motors have easy-access brushes.



SMALL-FRAME PMDC MOTOR SPECIFICATIONS

Motor Specifications – Small-Frame DC Motors										
Part Number	Voltage (VDC)	HP	Speed (rpm)	F.L. Torque (oz-in)	F.L. Current (A)	Shaft Dia (in)	Pilot Shaft (in)	Overhung Load (lb)	Wiring Type	Motor Weight (lb)
MTPM-P10-1JK43	12	1/20	1746	28	4.83	0.3125	1.00	85	flying leads	2.75
	24	1/10	4252							
MTPM-P13-1JK42	12	1/17	1825	32	5.39	0.3125	1.00	85	flying leads	3.25
	24	1/8	4224							
MTPM-P17-1JK43	12	1/13	1841	42	7.54	0.50	2.02	130	junction box	5.3
	24	1/16	4290							
MTPM-P25-1JK40	12	1/6	1732	96	14.3	0.50	2.02	130	junction box	7.8
	24	1/4	3996	80	12.2					
MTPM-P25-1JK44	12	1/5	1854	113	18.1	0.50	2.02	130	junction box	9
	24	1/4	4375	70	11.9					
MTPM-P03-1L18	90	1/31	1797	18	0.39	0.3125	1.00	85	flying leads	2.75
MTPM-P04-1L17		1/26	1749	22	0.46					
MTPM-P05-1L19		1/19	1917	28	0.68					
MTPM-P13-1L19		1/8	1917	73	1.4					
MTPM-P14-1L19		1/7	1740	86	1.61					
MTPM-P07-1M24		1/15	2440	28	0.42					
MTPM-P13-1M19	180	1/8	1865	73	0.73	0.50	2.02	130	junction box	7.8
		1/7	1828	84	0.83					
MTPM-P14-1M18		1/7	1828	84	0.83					

ROLLED STEEL 56C FRAME PERMANENT MAGNET DC (PMDC) MOTORS



IronHorse 56C frame PMDC motors are available from 1/3 hp to 2hp. All models have a TEFC or TENV rolled steel frame, cast aluminum end bell and removable mounting bases. Motors have easy-access brushes.

ROLLED STEEL 56C FRAME PMDC MOTOR SPECIFICATIONS

Motor Specifications – DC 56C Frame Motors – 1800 RPM									
Part Number	HP	Base RPM	Armature Voltage	Housing	NEMA Frame	Service Factor	F.L. Amps	Motor Weight (lb)	Approx Ship Weight (lb)
MTPM-P33-1L18	1/3	1800	90 VDC	TENV	56C flange mount	1.0	3.5	17.70	19
MTPM-P50-1L18	1/2			TENV			5.2	20.74	22
MTPM-P75-1L18	3/4			TEFC			7.8	25.30	27
MTPM-001-1L18	1			TEFC			10.4	28.36	30
MTPM-1P5-1L18	1-1/2			TEFC			15.4	34.97	37
MTPM-P33-1M18	1/3		180 VDC	TENV			1.75	17.60	19
MTPM-P50-1M18	1/2			TENV			2.6	20.74	22
MTPM-P75-1M18	3/4			TEFC			3.9	25.58	27
MTPM-001-1M18	1			TEFC			5.2	28.32	30
MTPM-1P5-1M18	1-1/2			TEFC			7.7	35.70	37
MTPM-002-1M18	2				9.8	61.95	65		

Note: Please review the AutomationDirect Terms & Conditions for warranty and service on this product.

ROLLED STEEL 56C FRAME PMDC PERFORMANCE DATA

Performance Data * – DC 56C Frame Motors – 1800 RPM																	
Part Number	HP	Armature Voltage (VDC)	Armature Resistance (Ω)	Torque (lb-ft)	DC Power Form Factor **	Ambient Temp. (°C [°F])	Insulation Class	Ball Bearings		Mounting	Wire / Housing	Shaft	Constant Torque Speed Range	Overall Speed Range	Base / Type	Paint Color	Efficiency (%)
				Full Load				DE	ODE								
MTPM-P33-1L18	1/3	90	1.85	0.97	1.35	40°C (104°F)	F	6203	Top Mounted	Junction Box	Keyed	90-1800 RPM	0-2000 RPM	Rigid Removable	Gray	79	
MTPM-P50-1L18	1/2		1.31	1.46												80	
MTPM-P75-1L18	3/4		0.86	2.19												80	
MTPM-001-1L18	1		0.67	2.92												80	
MTPM-1P5-1L18	1-1/2		1.45	4.38												81	
MTPM-P33-1M18	1/3	180	7.6	0.97												79	
MTPM-P50-1M18	1/2		5.25	1.46												80	
MTPM-P75-1M18	3/4		3.23	2.19												80	
MTPM-001-1M18	1		2.63	2.92												80	
MTPM-1P5-1M18	1-1/2		1.45	4.38												81	
MTPM-002-1M18	2		1.45	5.84	85												

* For performance curves and additional data, refer to Chapter 5: Reference.
 ** See the discussion of Form Factor in the following section of this chapter.

PERMANENT MAGNET DC MOTORS FEATURES AND SPECIFICATIONS (CONTINUED)

FORM FACTOR

The voltage normally used to power a permanent magnet (PM) DC motor is not pure DC. It is derived by rectifying a supplied AC voltage. The resulting DC voltage has a ripple that is related to the frequency of the AC input, as shown in the example below.

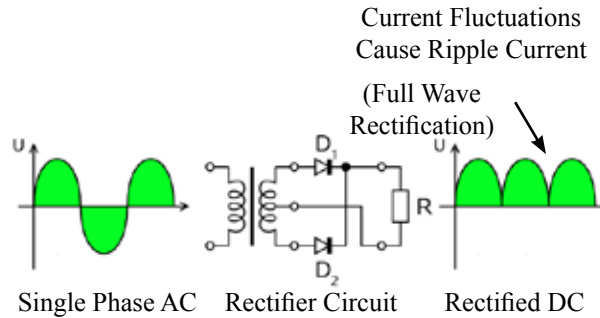

Form factor is the ratio of I_{rms} to I_{dc} and indicates how close the driving voltage is to pure DC. The form factor for a DC battery is 1.0. The higher the form factor is above 1.0, the more it deviates from pure DC. The Form Factor Table shows examples of commonly used voltages.

Form factor should not exceed 1.35 for continuous operation. Half wave rectification is not recommended as it increases form factor.

Operating Ironhorse PMDC motors with DC voltages with form factors higher than 1.35 can result in premature brush failure and excessive motor heating.

Form Factor Table	
Form factor	DC voltage source
1.0	Battery (pure DC)
1.05 *	Pulse width modulation (PWM)
1.35 **	Full wave rectification (single phase)
1.9 ***	Half wave rectification (single phase)
* All DC-input IronHorse GSD series DC drives are 1.05. IronHorse AC-input GSD5 DC drive is 1.05. ** Single phase full wave rectification is the most common form of DC drive in 0.33–2 hp range. All AC-input IronHorse GSD series DC drives are 1.35 or better. *** Not Recommended.	

RESHIPING

If an IronHorse motor needs to be reshipped from the initial shipping point, the following procedures should be followed to protect the motor from damage.

- 1) If the original packaging is to be used for reshipment, inspect the packaging for previous shipping damage and repackage if necessary. Take care to protect the motor body, fan cover and shaft.
- 2) It is a good idea to bolt or strap the motor to a platform that fits securely in the bottom of the shipping crate or box. This helps prevent the motor from shifting during transport and thus protects the bearings from damage.

LONG TERM STORAGE

The following preventative measures should be taken when storing IronHorse motors for a long period of time.

- 1) Store motors in a controller temperature, dry atmosphere free of excess dirt, dust and airborne particles.
- 2) Rotate the motor shaft every sixty days to prevent hardening of the bearing grease.

WARRANTY

IronHorse 56C-frame PMDC motors carry a two year warranty from the date of invoice, and the small-frame PMDC motors carry our standard one year warranty.