

BARRIER KITS

BUL87542
REV. A

ASSEMBLY INSTRUCTIONS FOR ALL BKFM AND BKWM SIZES

PARTS LIST			
ITEM	DESCRIPTION	QTY (42" & OVER)	QTY (36" & UNDER)
1	1/4 - 20 X 3/8" SCREW	6	4
2	1/4 - 20 X 1/2" SCREW	4	4
3	1/4 - 20 KEP NUT	6	6
4	ANGLE BRACKET	2	2
5	SEALING WASHER	4	4

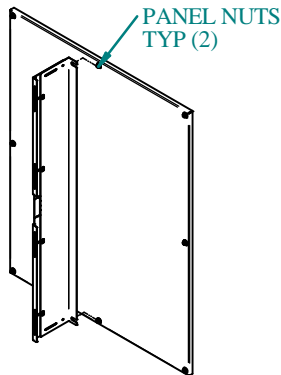

FIG. 1

- LOOSEN PANEL NUTS AS SHOWN IN FIG. 1
- SLIDE BARRIER BETWEEN WASHER AND BACK PANEL
- VERTICALLY CENTRE BARRIER TO INNER PANEL
- TIGHTEN PANEL NUTS.

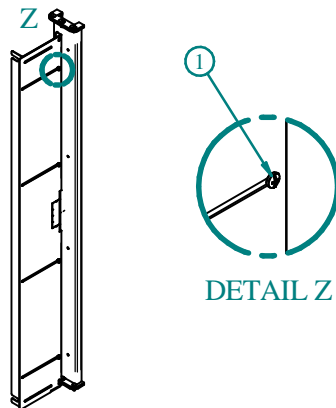

FIG. 2

- LOOSEN BARRIER SCREWS AS SHOWN IN FIG. 2
- SLIDE BARRIER TOWARDS CENTRE POST
- BREAK OFF CENTRE TAB IF REQUIRED
- DO NOT TIGHTEN BARRIER SCREWS

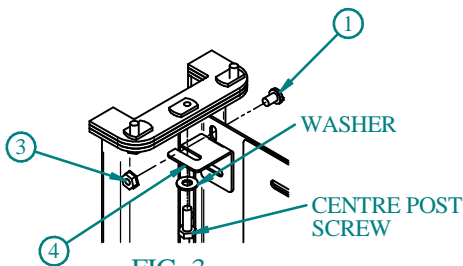

FIG. 3

- REMOVE CENTRE POST SCREW
- RE-INSTALL SCREW WITH WASHER (DO NOT TIGHTEN)
- INSTALL BRACKET AS SHOWN FIG. 3
- TIGHTEN CENTRE POST SCREWS
- REPEAT FOR BOTTOM BRACKET

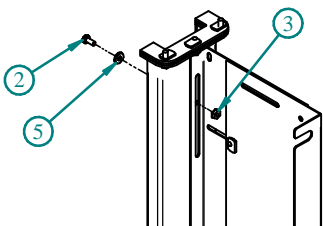

FIG. 4

- USE BARRIER AS TEMPLATE TO DRILL HOLES INTO CENTRE POST
- DRILL ONE HOLE PER SLOT
- INSTALL SCREW, SEALING WASHER AND NUT AS SHOWN IN FIG. 4
- TIGHTEN BARRIER SCREWS FIG. 2

TOOL BOX	Phillips Screw Driver	9/16 Open End Wrench	7/16 Open End Wrench

HAMMOND MANUFACTURING™
www.hammondmfg.com