

# HWST - SERIES

BUL86688

REV. B

## ASSEMBLY INSTRUCTIONS FOR HWST LEG KIT

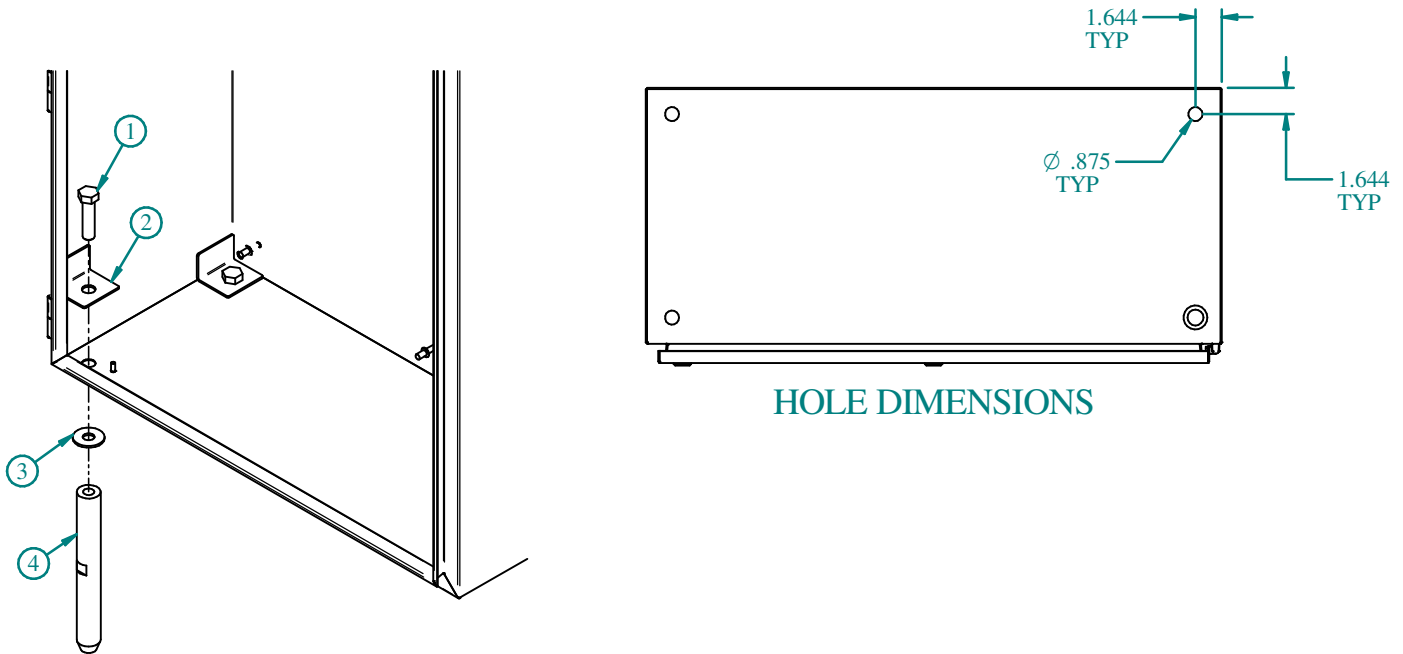

### FKIT316ST12 - ASSEMBLY INSTRUCTIONS

1. Mark hole locations as per the hole dimensions dwg in the bottom of the enclosure and drill the .875" hole required.
2. Place support bracket (Item 2) inside the enclosure over hole and put the 3/4" bolt (Item 1) through the hole. Place the rubber washer (Item 3) over the bolt on the outside of the enclosure and thread on the solid leg (Item 4). Tighten down.

FKIT316ST12		
ITEM #	DESCRIPTION	QTY
1	3/4-16 X 3" BOLT	2
2	SUPPORT BRACKET	2
3	RUBBER WASHER 5/8"ID 1.5"OD	2
4	SOLID LEG	2

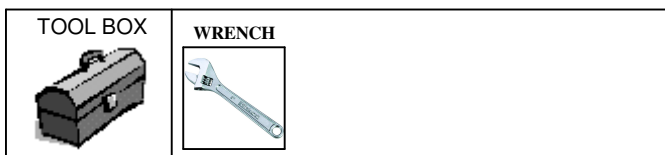

**HAMMOND**  
**MANUFACTURING™**  
www.hammondmfg.com