

# RMAD SERIES

## ASSEMBLY INSTRUCTIONS FOR RACK MOUNT ADJUSTABLE DIN RAIL

BUL10417

REV. A

Page: 1 of 1

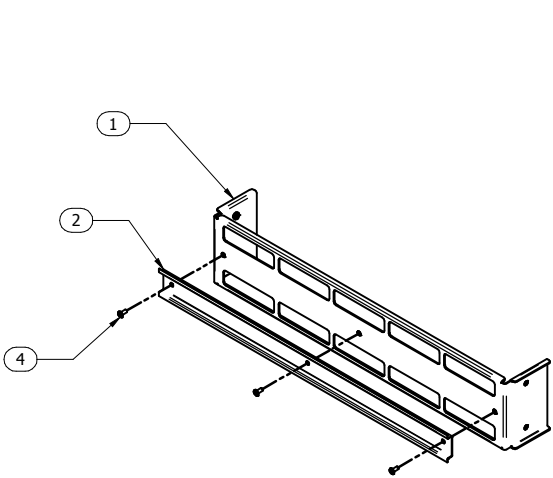

STEP 1 - DIN rail assembly

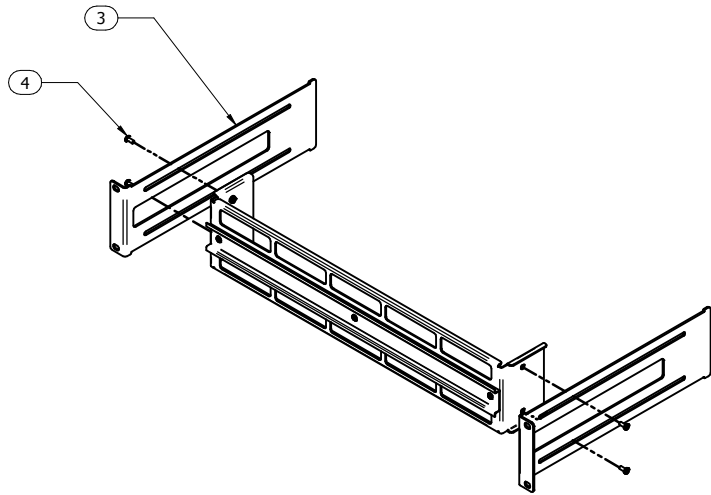

STEP 2 - Rail mounting flange assembly

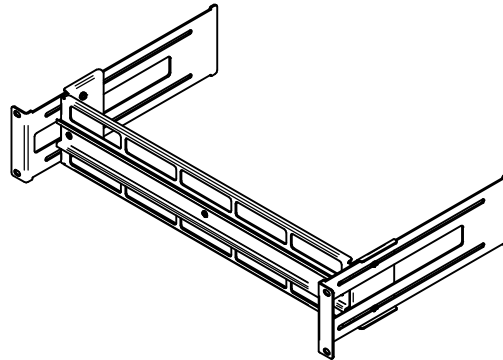

STEP 3 - Set depth

### PARTS LIST

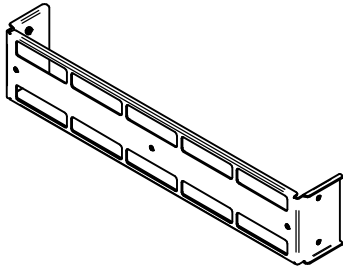

ITEM 1  
RMAD - MAIN BODY  
QTY 1

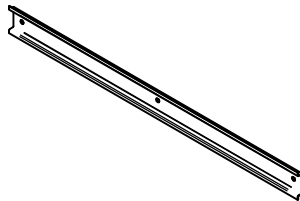

ITEM 2  
RMAD - BOLT-ON DIN RAIL  
QTY 1

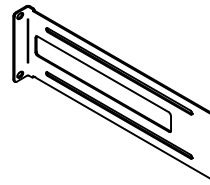

ITEM 3  
RMAD - RAIL MTG FLANGES  
QTY 2



ITEM 4  
SCREW 8-32 X 5/16"  
QTY 7

TOOL BOX



Phillips Head  
Screw Driver



**HAMMOND  
MANUFACTURING™**  
ELECTRONICS GROUP

visit our website @ [www.hammondmfg.com](http://www.hammondmfg.com)