

1487X - SERIES

BUL10140

REV. C

ASSEMBLY INSTRUCTIONS FOR 1487X SERIES ADJUSTABLE FITTING

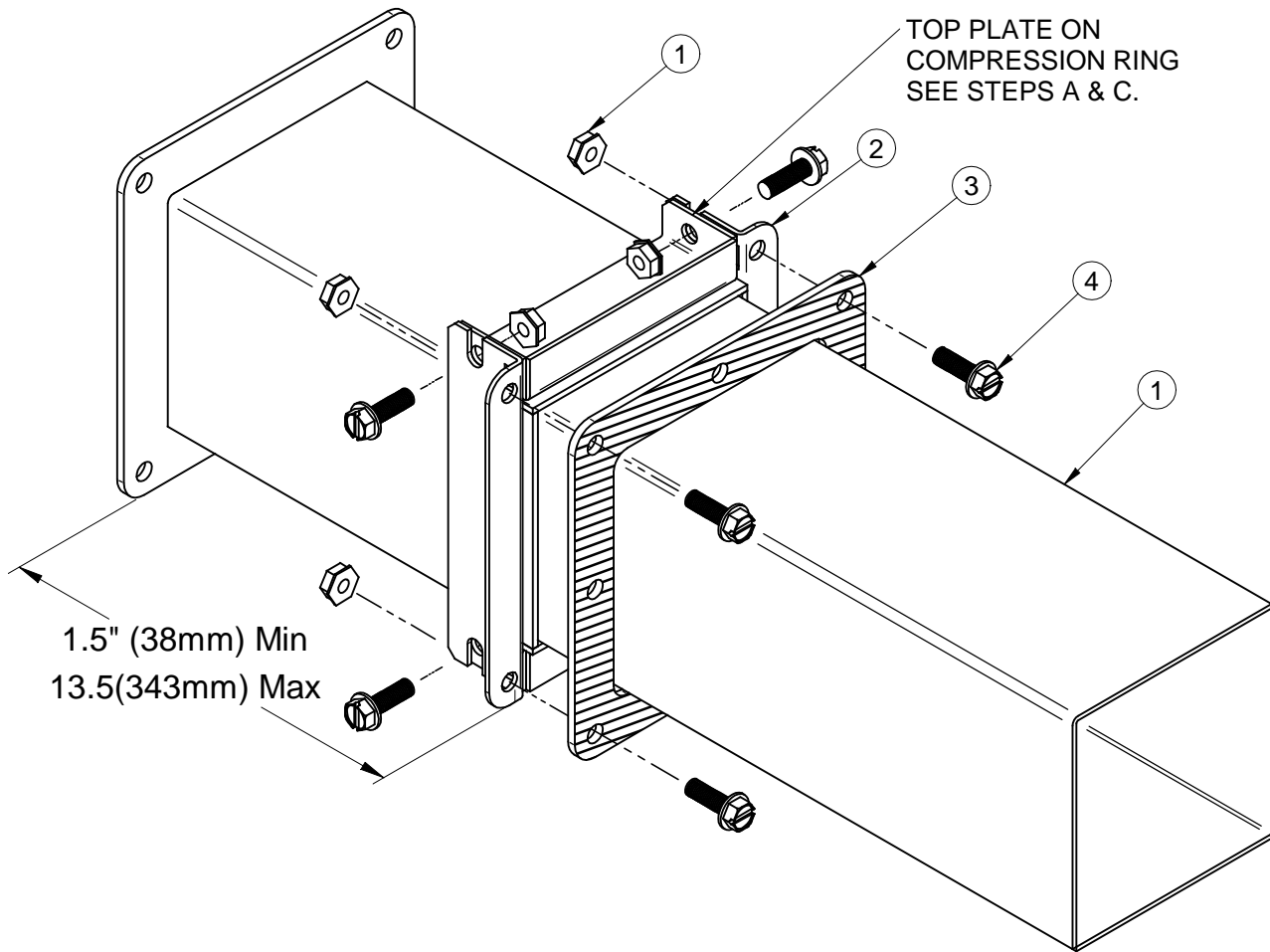

ASSEMBLY INSTRUCTIONS

Part #	QTY.	DESCRIPTION
1	1	1487 X ADJUSTABLE FITTING
2	1	COMPRESSION RING
3	1	SOLID FLANGE GASKET
4	8	1/4 - 20 X 3/4 HEX CAP SCREW
5	8	1/4 - 20 KEP NUT

- A) LOOSEN NUTS AND SCREWS HOLDING THE TOP PLATE ON THE COMPRESSION RING (PART 2). SLIP THE COMPRESSION RING OVER THE END OF THE ADJUSTABLE FITTING (PART 1). SLIP SOLID GASKET (PART 3) OVER THE END OF THE ADJUSTABLE FITTING.
- B) INSERT ADJUSTABLE FITTING INTO THE MATING WIREWAY AND POSITION TO THE DESIRED LENGTH. 1.5" (38mm) MIN TO 13.5" (343mm) MAX DISTANCE.
- C) FASTEN THE TOP PLATE DOWN SECURELY ON THE COMPRESSION RING THEN TIGHTEN THE NUTS AND SCREWS LOOSENED IN STEP A. FASTEN THE COMPRESSION RING AND SOLID HASKET USING 1/4 - 20 X .75 HEX HD. SCREWS AND 1/4 -20 KEP NUTS (PART 4 & 5) PROVIDED.

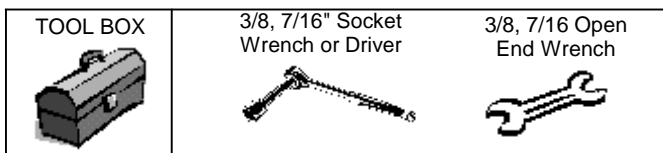

HAMMOND
MANUFACTURING™
ENCLOSURES