

# 1485X - SERIES

**BUL10094**

REV. C

ASSEMBLY INSTRUCTIONS

**ASSEMBLY INSTRUCTIONS FOR  
1485X ADJUSTABLE FITTING AND STRAIGHT SECTION**

- A) LOOSEN NUTS AND SCREWS HOLDING THE TOP PLATE ON THE COMPRESSION RING (PART 5). SLIP THE COMPRESSION RING OVER THE END OF THE ADJUSTABLE FITTING (PART 3). SLIP THE SOLID GASKET (PART 6) OVER THE END OF ADJUSTABLE FITTING.
- B) INSERT THE ADJUSTABLE FITTING INTO THE MATING WIREWAY AND POSITION TO THE DESIRED LENGTH. MAX DISTANCE 7" (178mm).
- C) SLIP BASE PLATE (PART 2) INTO MATING WIREWAY SO THAT THE TOP SEALING PLATE (PART 1) IS CENTERED OVER THE END FLANGE OF THE ADJUSTABLE FITTING. THE BASE PLATE IS SUPPORTED BY THE BASE PLATE SUPPORT ANGLE IN THE ADJUSTABLE FITTING.
- D) FASTEN THE TOP PLATE DOWN SECURELY ON THE COMPRESSION RING AND TIGHTEN THE NUTS AND SCREWS LOOSENED IN STEP A. FASTEN THE COMPRESSION RING AND SOLID GASKET TO THE FLANGE ON THE MATING WIREWAY USING 1/4 - 20 X .75 HEX HD. SCREWS AND 1/4 - 20 KEP NUTS (PARTS 4 & 7) PROVIDED.

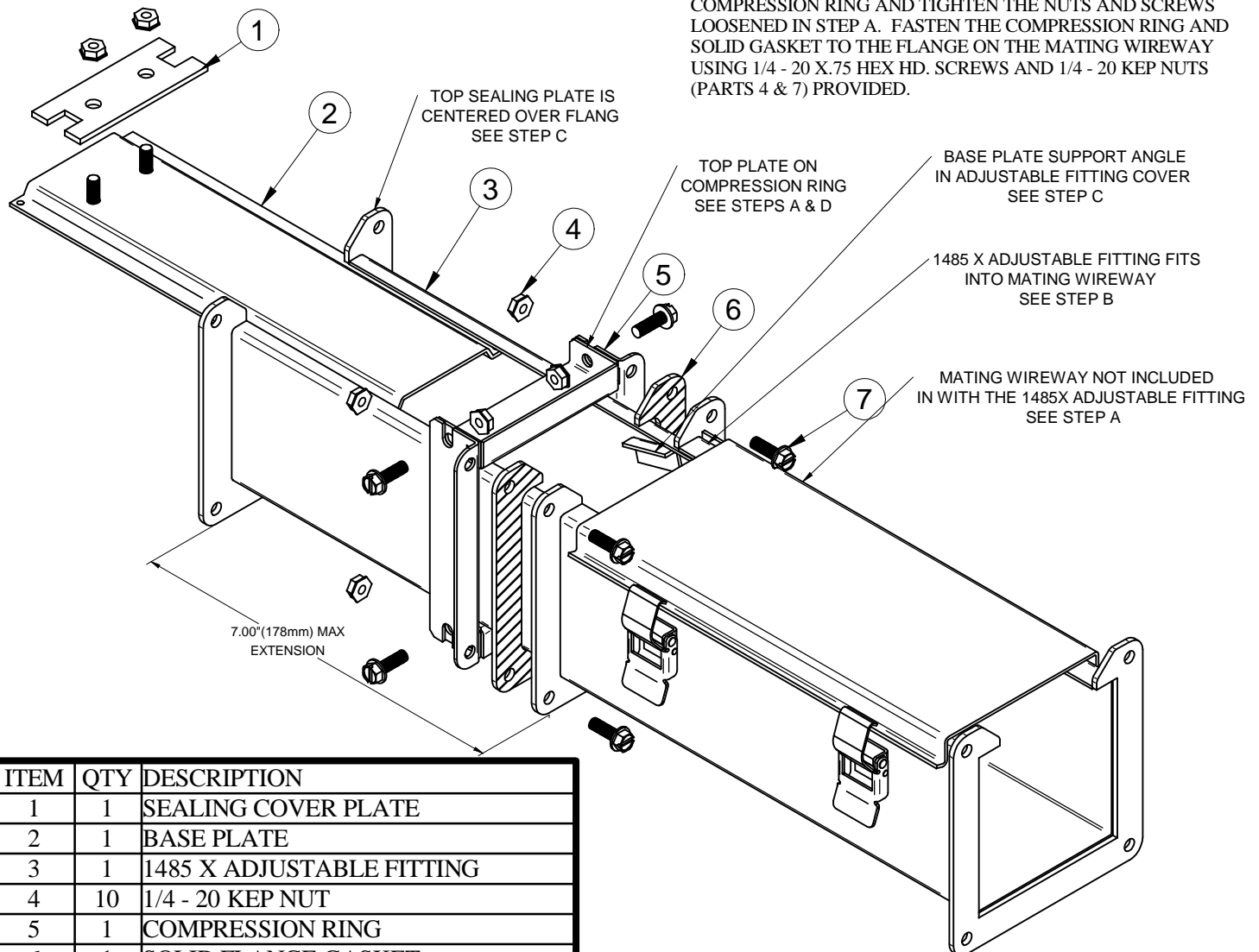

ITEM	QTY	DESCRIPTION
1	1	SEALING COVER PLATE
2	1	BASE PLATE
3	1	1485 X ADJUSTABLE FITTING
4	10	1/4 - 20 KEP NUT
5	1	COMPRESSION RING
6	1	SOLID FLANGE GASKET
7	8	1/4 - 20 X 3/4 HEX CAP SCREW

	3/8, 7/16" Socket Wrench or Driver	3/8, 7/16 Open End Wrench
	