

INSTALLATION AND WIRING



CHAPTER

2

TABLE OF CONTENTS

Chapter 2: Installation and Wiring

Drive Models by Frame Size	2-2
Installation	2-2
Minimum Clearances and Air Flow.	2-3
GS20 Series Minimum Clearance Distances	2-3
GS20 Airflow and Power Dissipation	2-4
GS20X Series Minimum Clearance Distances	2-5
GS20X Airflow and Power Dissipation	2-5
Dimensions.	2-6
Circuit Connections – RFI Jumper	2-16
RFI Jumper Removal.	2-16
Isolating Main Power from Ground	2-17
Floating Ground System (IT Systems)	2-18
Asymmetric Ground System (Corner Grounded TN Systems)	2-18
Circuit Connections – Warnings and Notes	2-19
Wiring Terminal Access	2-23
Control Terminal Access.	2-23
Main Circuit Wiring Terminals	2-24
Main Terminal Specifications	2-24
Wiring Terminal Connector Dimensions – Main-Circuit Terminals.	2-26
Main Terminal Diagrams	2-28
Main Circuit Wiring Diagrams	2-31
Control Circuit Wiring Terminals	2-31
GS20 & GS20X Control Terminal Specifications.	2-31
GS20 & GS20X Control Terminal Block Diagram & Wiring Specifications	2-34
Control Terminal Wiring Instructions.	2-35
Control Circuit Wiring Diagrams	2-36
Digital Inputs.	2-36
System Wiring Diagram.	2-37
Full I/O Wiring Diagram.	2-38

DRIVE MODELS BY FRAME SIZE

GS20 DURAPULSE Drive Models by Frame Size	
Frame	Drive
A	GS21-10P2, GS21-20P2, GS23-20P2, GS23-20P5, GS21-10P5, GS21-20P5, GS23-40P5, GS23-21P0, GS23-41P0, GS23-51P0
B	GS23-22P0, GS23-42P0, GS23-52P0, GS21-21P0
C	GS21-11P0, GS21-22P0, GS21-23P0, GS23-23P0, GS23-25P0, GS23-43P0, GS23-45P0, GS23-53P0, GS23-55P0
D	GS23-27P5, GS23-47P5, GS23-4010, GS23-57P5, GS23-5010
E	GS23-2010, GS23-2015, GS23-4015, GS23-4020
F	GS23-2020, GS23-4025, GS23-4030

GS20X DURAPULSE Drive Models by Frame Size	
Frame	Drive
A	GS21X-20P5, GS21X-21P0, GS21X-22P0, GS23X-20P5, GS23X-40P5, GS23X-41P0, GS21X-22P0, GS23X-22P0, GS23X-42P0, GS23X-43P0
B	GS21X-23P0, GS23X-23P0, GS23X-25P0, GS23X-45P0
C	GS23X-27P5, GS23X-47P5, GS23X-4010

INSTALLATION

Install the AC drive in an enclosure that is specifically designed to house electrical and electronic control equipment. Provide proper spacing within the enclosure to allow the dissipation of heat produced by the drive and any other included electrical and electronic equipment. Ventilation or air conditioning may also be required, depending upon the application.



FAILURE TO OBSERVE THESE PRECAUTIONS MAY DAMAGE THE DRIVE AND VOID THE WARRANTY!

Improper installation of the AC drive will greatly reduce its life. Observe the following precautions when installing the drive:

GS20:

- Do not mount the AC drive near heat-radiating elements or in direct sunlight.
- Do not install the AC drive in a place subjected to high temperature, high humidity, excessive vibration, corrosive gases or liquids, or airborne dust or metallic particles.
- Install the AC drive in Pollution Degree 2 environments only.
Pollution Degree 2: Normally only non-conductive pollution occurs. Temporary conductivity caused by condensation is to be expected.
- Install the AC drive in a cabinet. When installing one drive below another, use a metal separator between the drives to prevent mutual heating and to prevent the risk of fire.
- Mount the AC drive securely on a flat, rigid, non-flammable surface.
- Mount the AC drive vertically and do not restrict the air flow to the heat sink fins.
- Prevent fiber particles, scraps of paper, shredded wood saw dust, metal particles, etc. from adhering to the heat sink.

GS20X:

- Prevent fiber particles, scraps of paper, shredded wood, saw dust, metal particles, etc., from adhering to the heat sink.
- Install the AC motor drive in an incombustible (non-flammable) indoor environment to prevent the risk of accidental fire.
- Install the AC motor drive in Pollution Degree 2 environments only: normally only nonconductive pollution occurs and temporary conductivity caused by condensation is expected.



AC DRIVES GENERATE A LARGE AMOUNT OF HEAT WHICH MAY DAMAGE THEM. AUXILIARY COOLING METHODS ARE TYPICALLY REQUIRED IN ORDER NOT TO EXCEED MAXIMUM AMBIENT TEMPERATURES.

MINIMUM CLEARANCES AND AIR FLOW

DIAGRAM DIRECTIONAL ARROWS

- Air Inflow: Blue Arrow → →
- Air Outflow: Red Arrow → →
- Distance: Black Arrows ↔ ↔

GS20 SERIES MINIMUM CLEARANCE DISTANCES

1) SINGLE DRIVE INSTALLATION (FRAMES A–F)

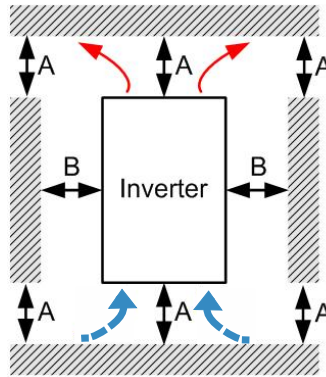

2) MULTIPLE DRIVES SIDE-BY-SIDE

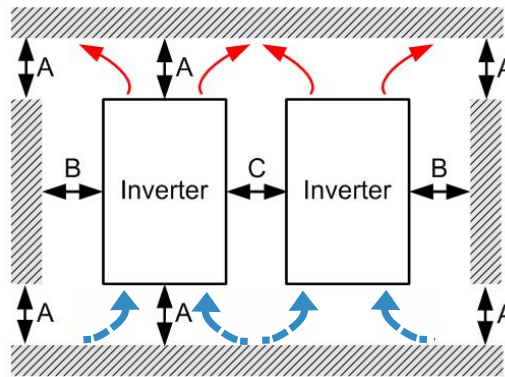

GS20 Minimum Mounting Clearances*					
Installation Method	A (mm)	B (mm)	C (mm)	Operation Temperature (°C)	
				Max (w/out derating)	Max (Derating)
Single drive installation	50	30	–	50	60
Side-by-side horizontal installation	50	30	30	50	60
Zero stack installation	50	30	0	40	50

* The minimum mounting clearances stated in this table apply to GS20 drives frames A to F. Failure to follow the minimum mounting clearances may cause the fan to malfunction and cause a heat dissipation problem.

GS20 AIRFLOW AND POWER DISSIPATION

GS20 Airflow and Power Dissipation						
Model Number	Frame Size	Airflow Rate for Cooling		Power Dissipation (Watts)		
		Flow Rate (cfm)	Flow Rate (m ³ /hr)	Loss External (Heat sink)	Internal	Total
GS21-10P2	A	0.0	0.0	8.0	10.0	18.0
GS21-10P5				14.2	13.1	27.3
GS21-11P0	C	16.0	27.2	29.1	23.9	53.0
GS21-20P2	A	0.0	0.0	8.0	10.3	18.3
GS21-20P5				16.3	14.5	30.8
GS21-21P0	B			29.1	20.1	49.2
GS21-22P0	C	16.0	27.2	29.1	23.9	53.0
GS21-23P0				70.0	35	105
GS23-2010	E	53.7	91.2	244.5	79.6	324.1
GS23-2015				374.2	86.2	460.4
GS23-2020	F	67.9	115.2	492.0	198.2	690.2
GS23-20P2	A	0.0	0.0	8.6	10.0	18.6
GS23-20P5				16.5	12.6	29.1
GS23-21P0				31.0	13.2	44.2
GS23-22P0	B	10.0	16.99	50.1	24.2	74.3
GS23-23P0	C	16.0	27.2	76.0	30.7	106.7
GS23-25P0				108.2	40.1	148.3
GS23-27P5	D	23.4	39.7	192.8	53.3	246.1
GS23-4010				164.7	55.8	220.5
GS23-4015	E	53.7	91.2	234.5	69.8	304.3
GS23-4020				319.8	74.3	394.1
GS23-4025	F	67.9	115.2	423.5	181.6	605.1
GS23-4030				501.1	200.3	701.4
GS23-40P5	A	10.0	16.99	17.6	11.1	28.7
GS23-41P0				30.5	17.8	48.3
GS23-42P0	B			45.9	21.7	67.6
GS23-43P0	C	16.0	27.2	60.6	22.8	83.4
GS23-45P0				93.1	42	135.1
GS23-47P5	D	23.4	39.7	132.8	39.5	172.3
GS23-5010				108.4	51	159.4
GS23-51P0	A	0.0	0.0	23.5	12.5	36
GS23-52P0	B	10.0	16.99	38.1	19	57.1
GS23-53P0	C	16.0	27.2	56.6	22.2	68.8
GS23-55P0				76.1	30	106.1
GS23-57P5	D	23.4	39.7	93.9	37	130.9

- Published flow rates are the result of active cooling using fans, factory installed in the drive.
- Unpublished flow rates (0.0) are the result of passive cooling in drives without factory installed fans.
- The required airflow shown in the chart is for installing a single GS20 drive in a confined space.
- When installing multiple GS20 drives, the required air volume would be the required air volume for a single GS20 drive multiplied by the number of GS20 drives.
- When calculating power dissipation (Watt Loss), use the Total value. Heat dissipation shown in the chart is for installing a single GS20 drive in a confined space.
- When installing multiple drives, the volume of heat/power dissipation should be the heat/power dissipated by a single GS20 drive multiplied by the number of GS20 drives.
- Heat dissipation for each model is calculated by rated voltage, current and default carrier frequency.

GS20X SERIES MINIMUM CLEARANCE DISTANCES

DIAGRAM DIRECTIONAL ARROWS

- Air Inflow: Blue Arrow → →
- Air Outflow: Red Arrow → →
- Distance: Black Arrows ↔ ↔

1) SINGLE DRIVE INSTALLATION (FRAMES A–C)

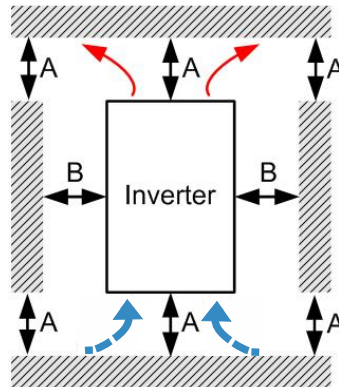

GS20X Minimum Mounting Clearances*				
Installation Method	A (mm)	B (mm)	Operation Temperature (°C)	
			Max (w/out derating)	Max (Derating)
Single drive installation	50	30	40	50

* The minimum mounting clearances stated in this table apply to GS20X drives frames A to C. Failure to follow the minimum mounting clearances may cause a heat dissipation problem.

GS20X AIRFLOW AND POWER DISSIPATION

GS20X Airflow and Power Dissipation						
Model Number	Frame Size	Airflow Rate for Cooling		Power Dissipation (Watts)		
		Flow Rate (cfm)	Flow Rate (m ³ /hr)	Loss External (Heat sink)	Internal	Total
GS21X-20P5	A	0.0	0.0	16.3	14.5	30.8
GS21X-21P0				29.1	20.1	49.2
GS23X-20P5				16.5	12.6	29.1
GS23X-21P0				29.1	20.1	49.2
GS23X-40P5				17.6	11.1	28.7
GS23X-41P0				30.5	17.8	48.3
GS21X-22P0				46.5	31	77.5
GS23X-22P0				50.1	24.2	74.3
GS23X-42P0				45.9	21.7	67.6
GS23X-43P0				60.6	22.8	83.4
GS21X-23P0				B	27.3	46.4
GS23X-23P0	76.0	30.7	106.7			
GS23X-25P0	108.2	40.1	148.3			
GS23X-45P0	93.1	42.0	135.1			
GS23X-27P5	C	33.5	56.6	192.8	53.3	246.1
GS23X-47P5				132.8	39.5	172.3
GS23X-4010				164.7	53.3	246.1

- Published flow rates are the result of active cooling using fans, factory installed in the drive.
- Unpublished flow rates (-) are the result of passive cooling in drives without factory installed fans.
- The required airflow shown in the chart is for installing a single GS20X drive in a confined space.
- When calculating power dissipation (Watt Loss), use the Total value. Heat dissipation shown in the chart is for installing a single GS20X drive in a confined space.
- Heat dissipation for each model is calculated by rated voltage, current and default carrier frequency.

DIMENSIONS

(Units = mm [in])

See our website: for complete engineering drawings and 3D models.

GS20 DURAPULSE Frame Sizes by Drive Model							
120V		230V		460V		575V	
<i>Drive</i>	<i>Frame</i>	<i>Drive</i>	<i>Frame</i>	<i>Drive</i>	<i>Frame</i>	<i>Drive</i>	<i>Frame</i>
GS21-10P2	A1	GS21-20P2	A1	GS23-40P5	A4	GS23-51P0	A5
GS21-10P5	A3	GS21-20P5	A3	GS23-41P0	A5	GS23-52P0	B1
GS21-11P0	C1	GS21-21P0	B2	GS23-42P0	B1	GS23-53P0	C1
		GS21-22P0	C1	GS23-43P0	C1	GS23-55P0	C1
		GS21-23P0	C1	GS23-45P0	C1	GS23-57P5	D1
		GS23-20P2	A1	GS23-47P5	D1	GS23-5010	D1
		GS23-20P5	A2	GS23-4010	D1		
		GS23-21P0	A5	GS23-4015	E1		
		GS23-22P0	B1	GS23-4020	E1		
		GS23-23P0	C1	GS23-4025	F1		
		GS23-25P0	C1	GS23-4030	F1		
		GS23-27P5	D1				
		GS23-2010	E1				
		GS23-2015	E1				
		GS23-2020	F1				

GS20X DURAPULSE Frame Sizes by Drive Model			
230V		460V	
<i>Drive</i>	<i>Frame</i>	<i>Drive</i>	<i>Frame</i>
GS21X-20P5	A1	GS23X-40P5	A1
GS21X-21P0	A1	GS23X-41P0	A1
GS21X-22P0	A2	GS23X-42P0	A2
GS21X-23P0	B	GS23X-43P0	A3
GS23X-20P5	A1	GS23X-45P0	B
GS23X-21P0	A1	GS23X-47P5	C
GS23X-22P0	A2	GS23X-4010	C
GS23X-23P0	B		
GS23X-25P0	B		
GS23X-27P5	C		

DIMENSIONS (Units = mm [in])

See our website: www.AutomationDirect.com for complete engineering drawings and 3D models.

GS20 FRAME SIZE A

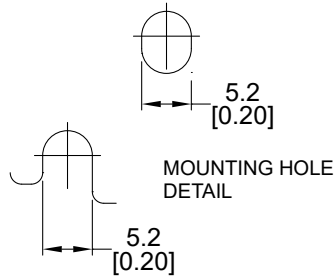
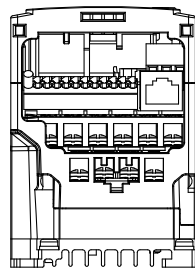
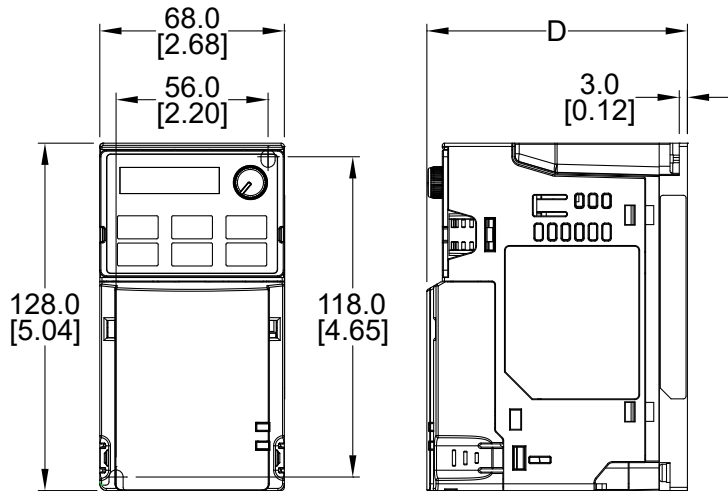

A Frame "D" Dimension	
Frame	D mm [in]
A1	96.0 [3.78]
A2	110.0 [4.33]
A3	125.0 [4.92]
A4	129.0 [5.08]
A5	143.0 [5.63]

GS20 FRAME SIZE A CONDUIT BOX

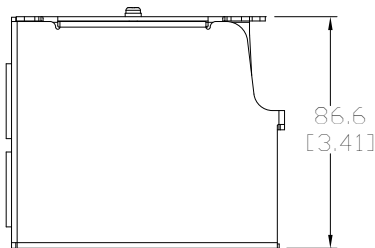
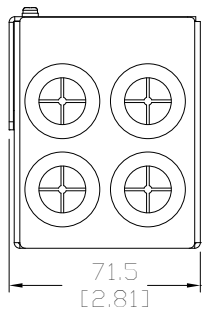
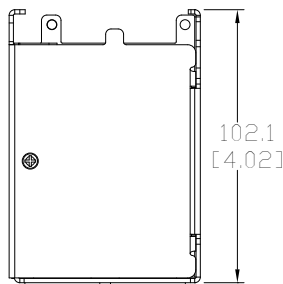

DIMENSIONS (Units = mm [in])

See our website: www.AutomationDirect.com for complete engineering drawings and 3D models.

GS20 FRAME SIZE B

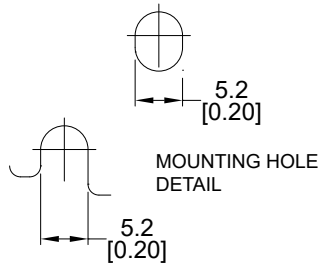
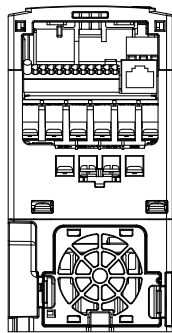
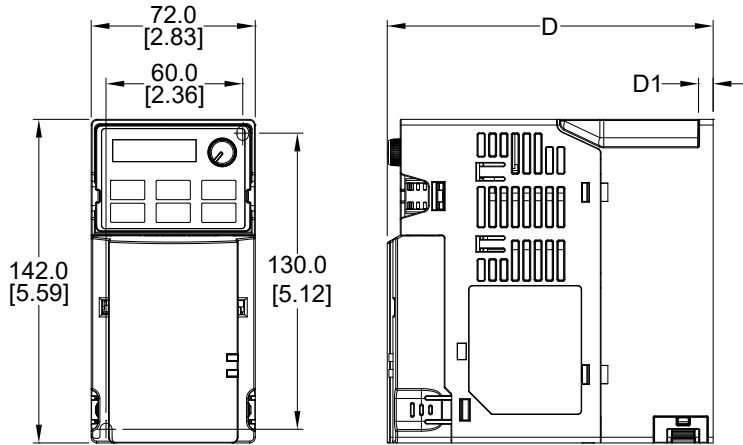

B Frame "D" & "D1" Dimensions		
Frame	D mm [in]	D1 mm [in]
B1	143.0 [5.63]	6.4 [0.25]
B2	143.0 [5.63]	3.0 [0.12]



NOTE: B2 frame does not have a cooling fan.

GS20 FRAME SIZE B CONDUIT BOX

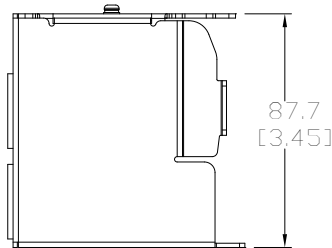
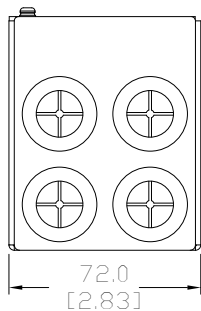
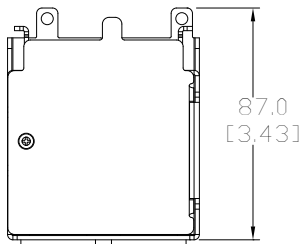

DIMENSIONS (Units = mm [in])

See our website: www.AutomationDirect.com for complete engineering drawings and 3D models.

GS20 FRAME SIZE C

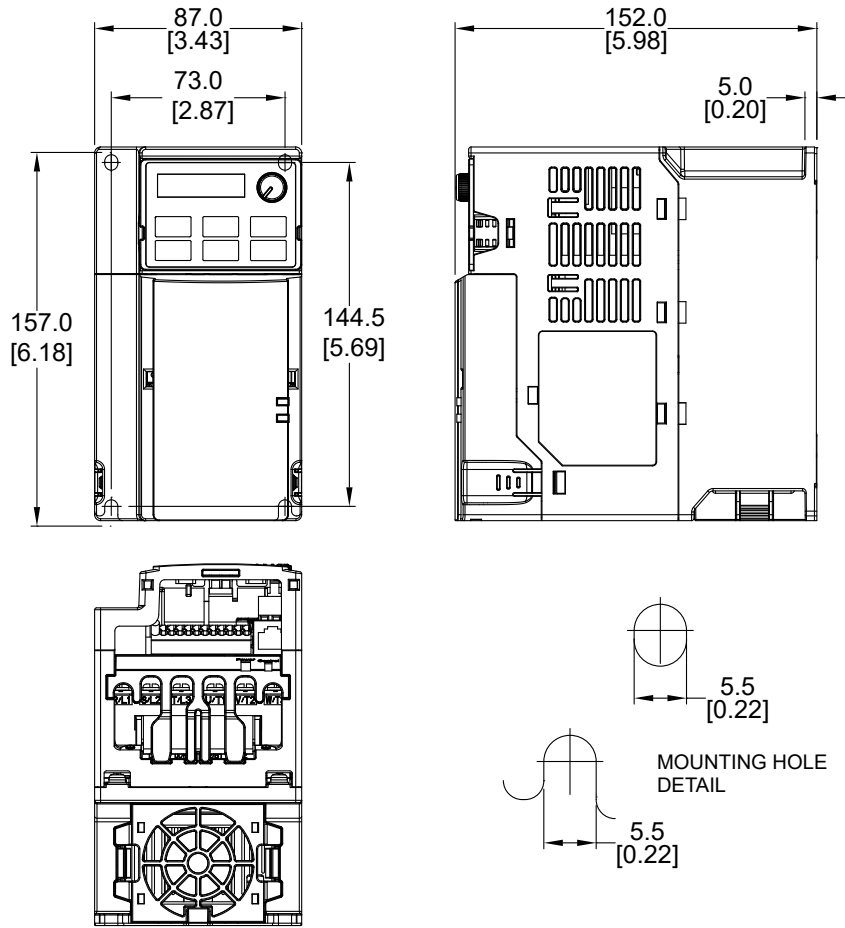

GS20 FRAME SIZE C CONDUIT BOX

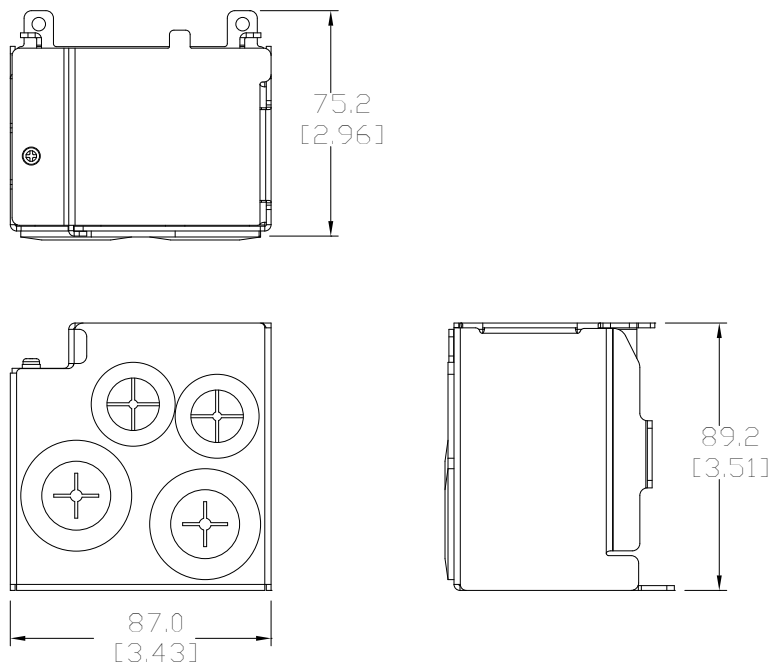

DIMENSIONS (Units = mm [in])

See our website: www.AutomationDirect.com for complete engineering drawings and 3D models.

GS20 FRAME SIZE D

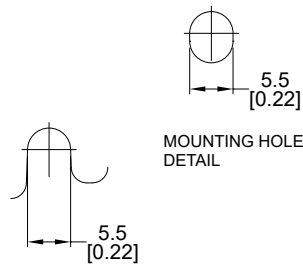
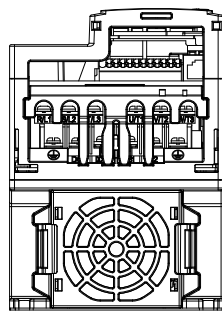
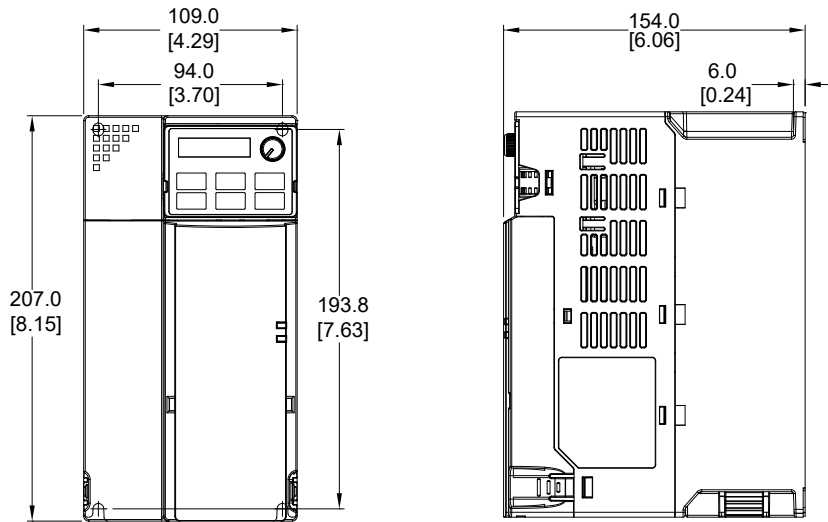

GS20 FRAME SIZE D CONDUIT BOX

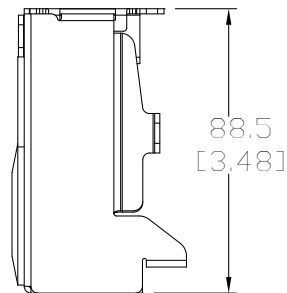
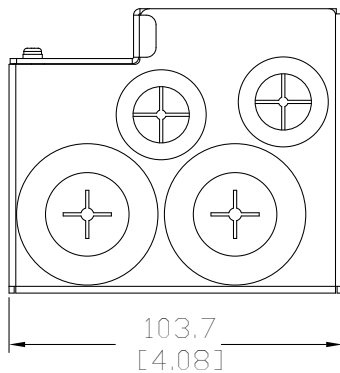
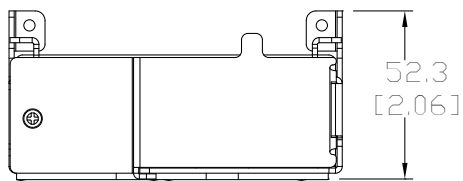

DIMENSIONS (Units = mm [in])

See our website: www.AutomationDirect.com for complete engineering drawings and 3D models.

GS20 FRAME SIZE E

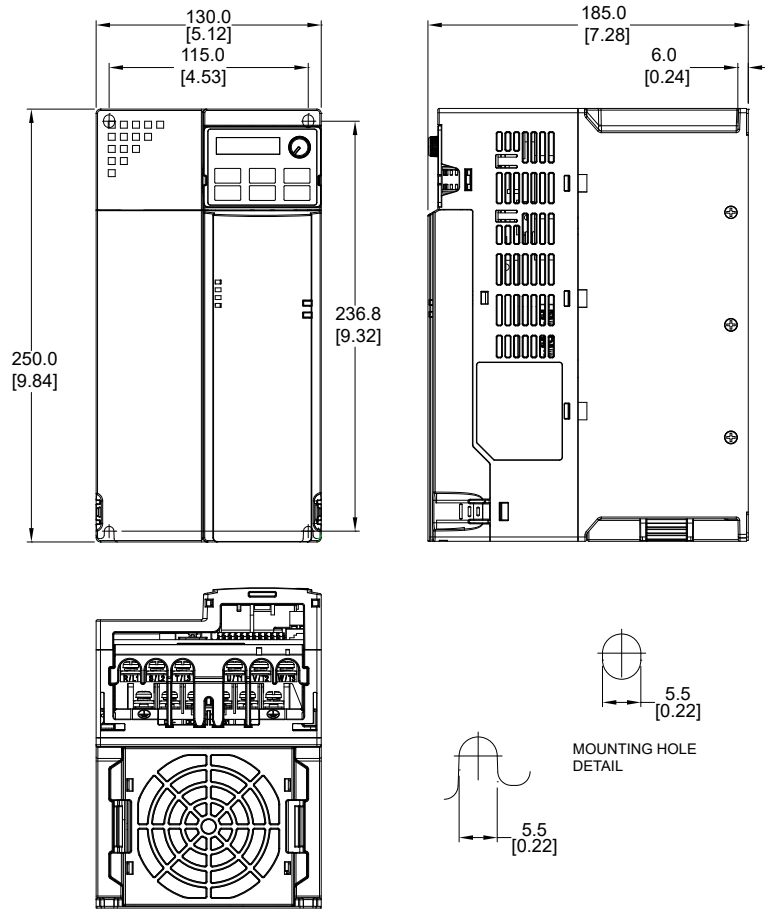

GS20 FRAME SIZE E CONDUIT BOX

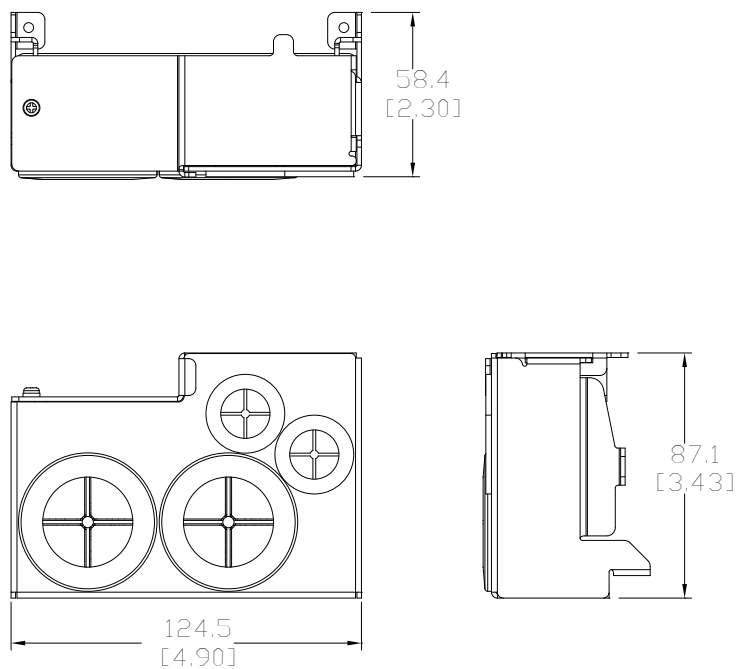

DIMENSIONS (Units = mm [in])

See our website: www.AutomationDirect.com for complete engineering drawings and 3D models.

GS20 FRAME SIZE F

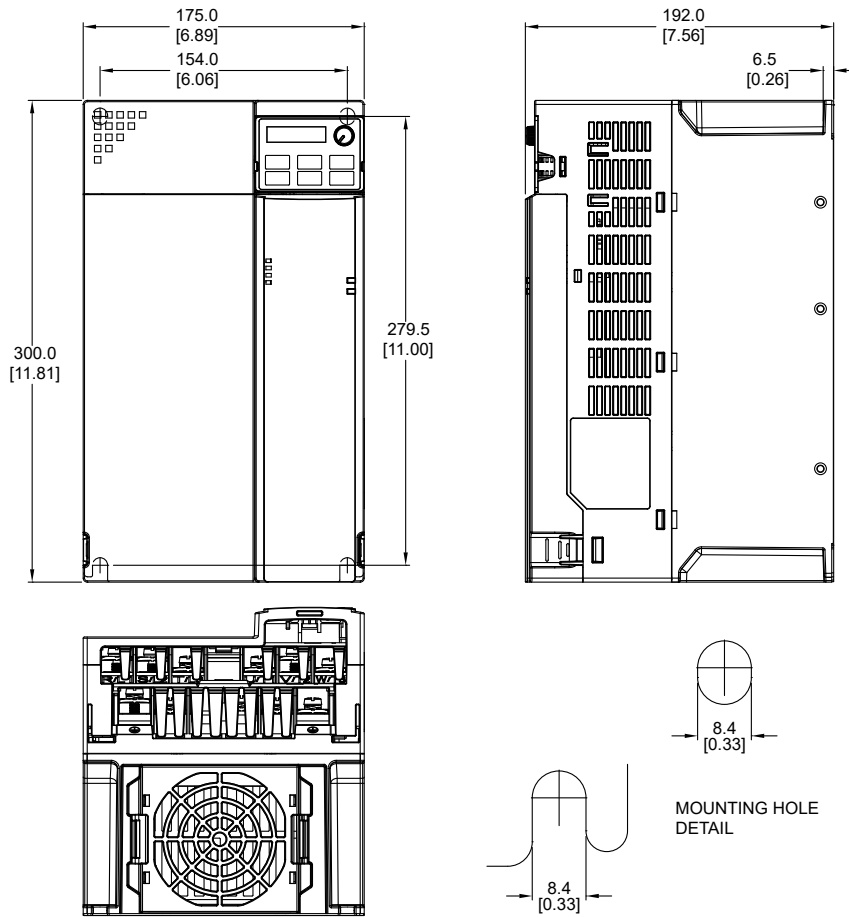

GS20 FRAME SIZE F CONDUIT BOX

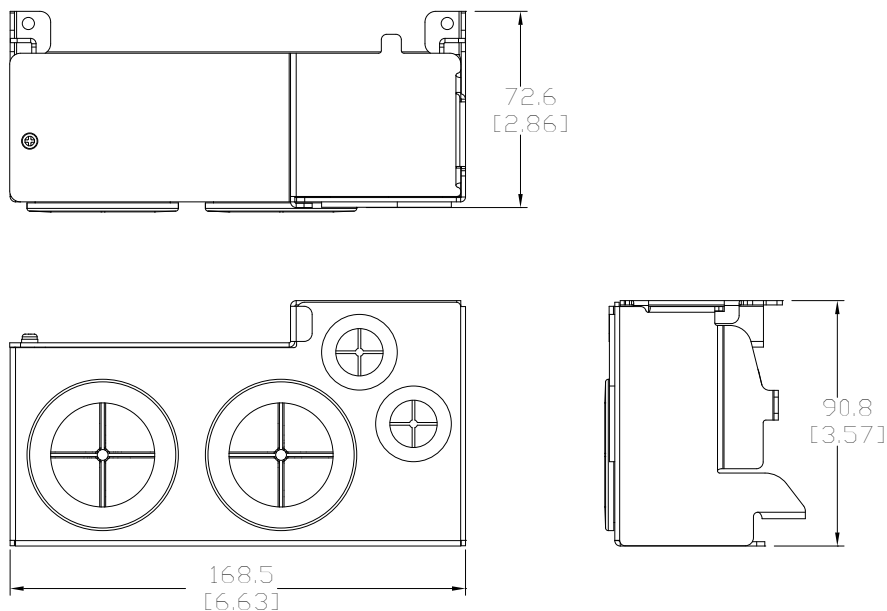

DIMENSIONS (Units = mm [in])

See our website: www.AutomationDirect.com for complete engineering drawings and 3D models.

GS20X FRAME SIZE A

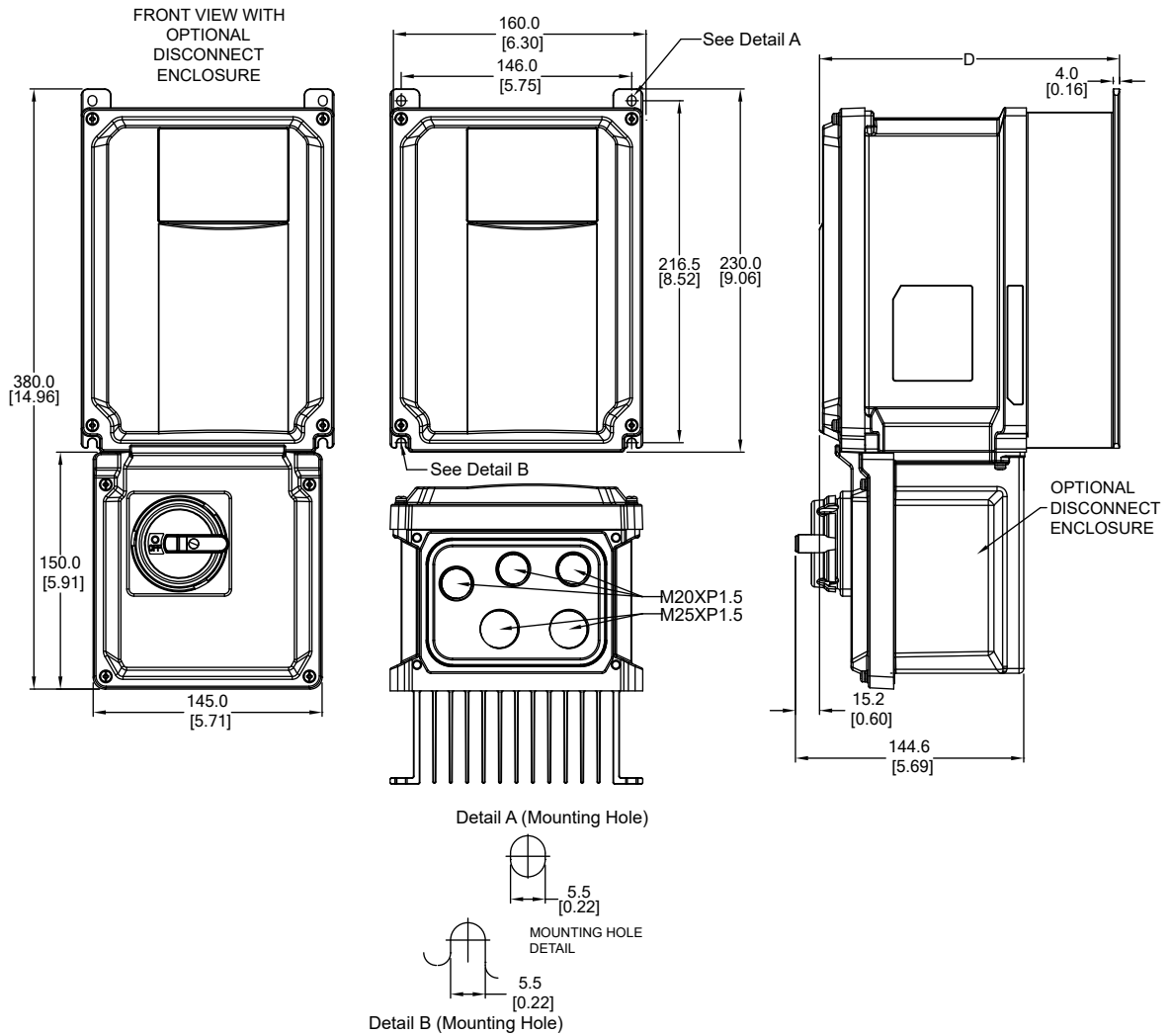

A Frame "D" Dimension	
Frame	D mm [in]
A1	151.0 [5.94]
A2	167.0 [6.57]
A3	190.0 [7.48]

DIMENSIONS (Units = mm [in])

See our website: www.AutomationDirect.com for complete engineering drawings and 3D models.

GS20X FRAME SIZE B

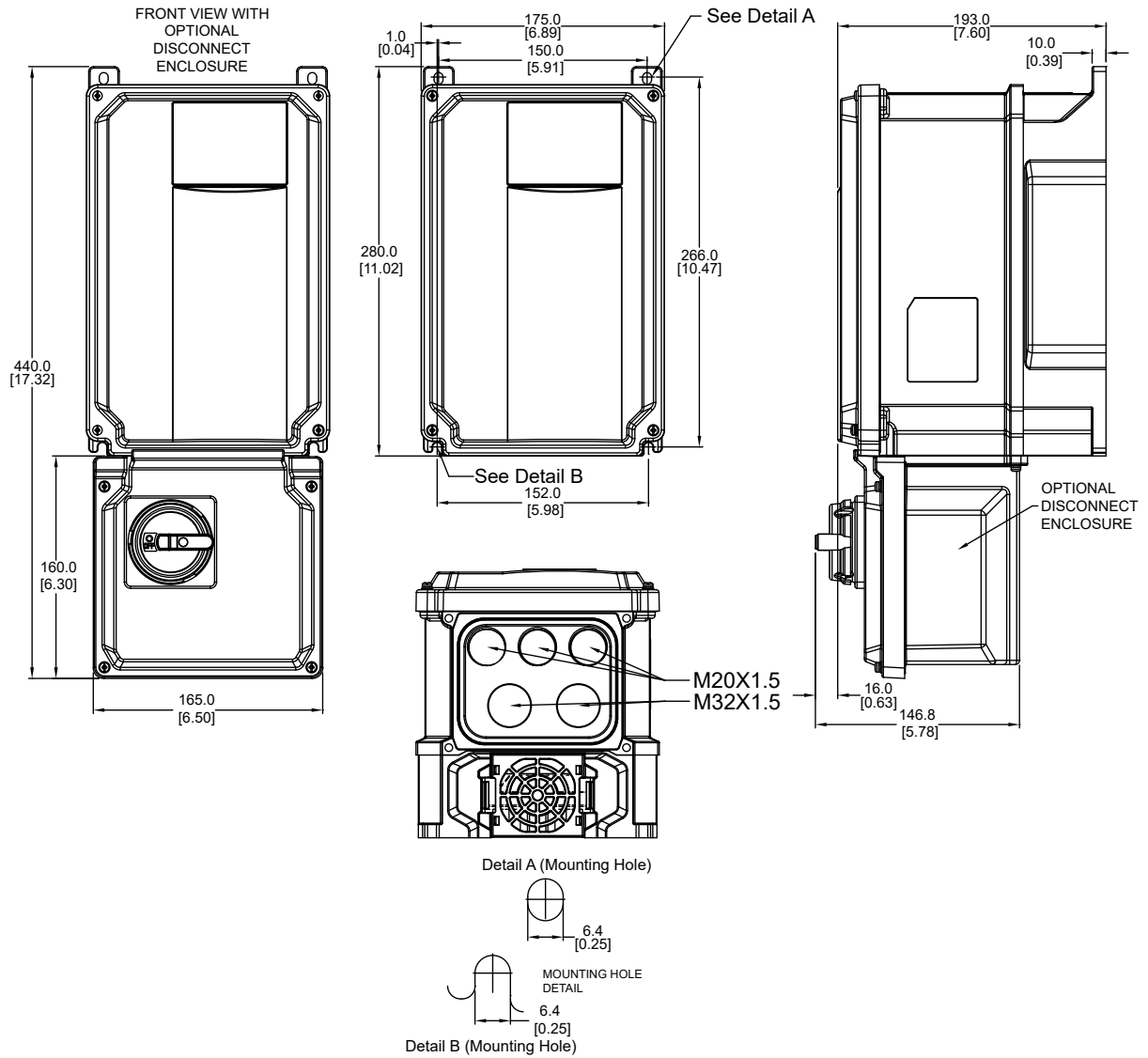

DIMENSIONS (Units = mm [in])

See our website: www.AutomationDirect.com for complete engineering drawings and 3D models.

GS20X FRAME SIZE C

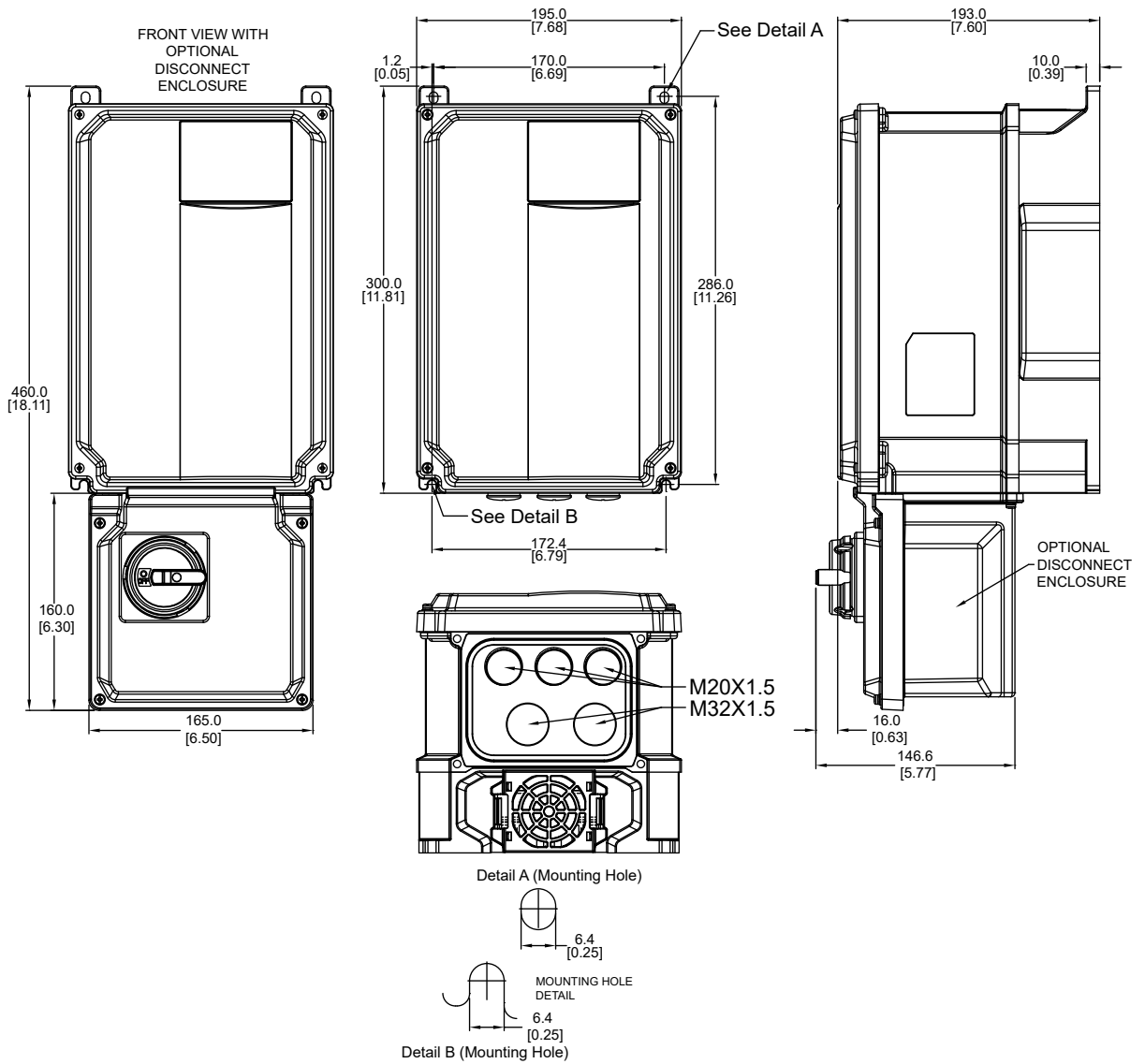

CIRCUIT CONNECTIONS – RFI JUMPER

RFI Jumper: The GS20 & GS20X drives may emit electrical noise. The drive contains Varistors / MOVs that are connected from phase to phase and from phase to ground to prevent the drive from unexpected stop or damage caused by mains surges or voltage spikes. Because the Varistors / MOVs from phase to ground are connected to ground with the RFI jumper, removing the RFI jumper disables the protection.

RFI JUMPER REMOVAL

The RFI jumper may need to be removed in some cases, such as situations in which the GS20(X) drive is powered from an Asymmetric Ground System (Corner Grounded TN System), as described on [page 2-18](#).

GS20 FRAMES A~F

Screw Torque: 4~6 kg·cm [3.5~5.2 lb·in]

Loosen the screw indicated in the view below, and remove the RFI jumper. Tighten the screw to the specified torque after the RFI jumper is removed.

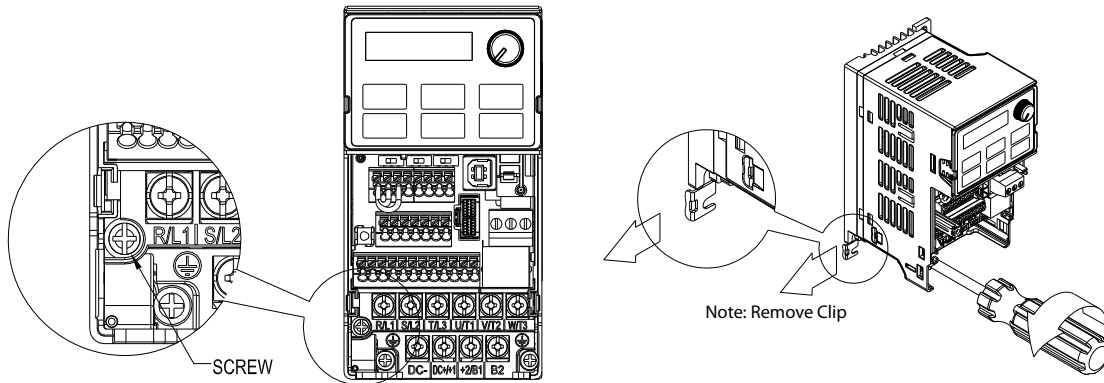

GS20X FRAMES A~C

Screw Torque: 4~6 kg·cm [3.5~5.2 lb·in]

Loosen the screw indicated in the view below, and remove the RFI jumper. Tighten the screw to the specified torque after the RFI jumper is removed.

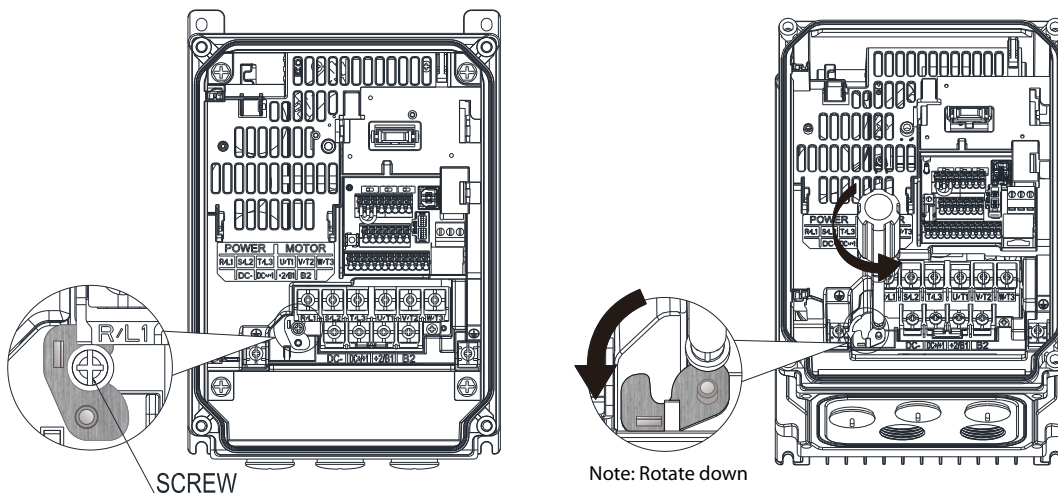

ISOLATING MAIN POWER FROM GROUND



WARNING: IF THE POWER DISTRIBUTION SYSTEM SUPPLYING THE GS20 OR GS20X DRIVE IS 120V, THE RFI JUMPER MUST BE REMOVED.



WARNING: IF THE POWER DISTRIBUTION SYSTEM SUPPLYING THE GS20 OR GS20X DRIVE IS A FLOATING-GROUND SYSTEM (IT) OR AN ASYMMETRIC-GROUND SYSTEM (TN), THE RFI JUMPER MUST BE REMOVED.

If the power distribution system supplying the GS20 or GS20X drive is a floating ground system (IT) or an asymmetric ground system (TN), the RFI jumper must be removed. Removing the RFI jumper disconnects the internal RFI filter capacitor between the drive’s frame and circuits to avoid damaging those circuits and to reduce ground leakage current.

Important points regarding ground connection

- To ensure the safety of personnel, proper operation, and to reduce electromagnetic radiation, the GS20 or GS20X drive must be properly grounded during installation.
- The diameter of the cables must meet the size specified by applicable codes and regulations.
- The shield of shielded cables must be connected to the ground of the GS20 or GS20X drive to meet safety regulations.
- The shield of shielded cables can be used as the ground for equipment only when the aforementioned points are met.
- When installing multiple GS20(X) drives, do not connect the grounds of the AC motor drive in series. Instead, utilize a single-point grounding scheme (as shown below), or provide individual grounding rods for each GS20(X) drive.

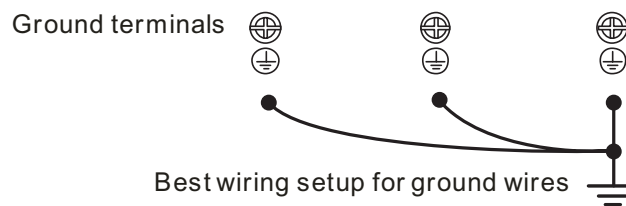

Pay particular attention to the following WARNINGS:



WARNING: DO NOT REMOVE THE RFI JUMPER WHILE POWER IS APPLIED TO THE GS20(X) DRIVE.



WARNING: CUTTING THE RFI SHORT-CIRCUIT CABLE WILL ALSO CUT OFF THE CONDUCTIVITY OF THE CAPACITOR. GAP DISCHARGE MAY OCCUR ONCE THE TRANSIENT VOLTAGE EXCEEDS 1000V.



WARNING: THE RFI JUMPER MAY NOT BE REMOVED IF THE MAIN POWER IS A SYMMETRICALLY GROUNDED POWER SYSTEM.



WARNING: THE RFI JUMPER MAY NOT BE REMOVED WHILE CONDUCTING HIGH VOLTAGE TESTS.



WARNING: WHEN CONDUCTING A HIGH VOLTAGE TEST TO THE ENTIRE FACILITY, THE MAIN POWER AND THE MOTOR MUST BE DISCONNECTED IF LEAKAGE CURRENT IS TOO HIGH.

FLOATING GROUND SYSTEM (IT SYSTEMS)

A floating ground system is also called an IT system, an ungrounded system, or a high impedance/resistance grounding system (greater than 30Ω).

Disconnect the RFI Jumper



CAUTION: DO NOT INSTALL AN EXTERNAL RFI/EMC FILTER! THE EMC FILTER WILL PASS THROUGH THE RFI CAPACITOR, THUS CONNECTING POWER INPUT TO GROUND. THIS IS VERY DANGEROUS AND CAN EASILY DAMAGE THE GS20 DRIVE.

ASYMMETRIC GROUND SYSTEM (CORNER GROUNDED TN SYSTEMS)



CAUTION: DO NOT REMOVE THE RFI JUMPER WHILE THE INPUT TERMINALS OF THE GS20 DRIVE CARRIES POWER.

The RFI jumper must be removed in the following four situations. This is to prevent the system from grounding through the RFI capacitor, damaging the GS20 drive.

RFI Jumper Must Be Removed (Asymmetric Ground / Corner Grounded TN Systems)	
<p>1) Grounding at a Corner of a Triangle Configuration</p>	<p>2) Grounding at a Midpoint in a Polygonal Configuration</p>
<p>3) Grounding at One End in a Single-Phase Configuration</p>	<p>4) No Stable Neutral Grounding in a Three-Phase Autotransformer Configuration</p>

The RFI jumper should be left in place for a symmetrically grounded system.

RFI Jumper Left In Place (Symmetrical Ground System)	
<p>Internal grounding through internal RFI filter, which reduces electromagnetic radiation.</p> <p>In a situation with higher requirements for electromagnetic compatibility, and using a symmetrical grounding power system, an EMC filter can be installed.</p> <p>As a reference, the diagram on the right is a symmetrical grounding power system.</p>	

CIRCUIT CONNECTIONS – WARNINGS AND NOTES

DANGER!

HAZARDOUS VOLTAGE! BEFORE MAKING ANY CONNECTION TO THE AC DRIVE, DISCONNECT ALL POWER TO THE AC DRIVE, AND WAIT FIVE MINUTES FOR DC BUS CAPACITORS TO DISCHARGE.



WARNING: ANY ELECTRICAL OR MECHANICAL MODIFICATION TO THIS EQUIPMENT WILL VOID ALL WARRANTIES, MAY RESULT IN A SAFETY HAZARD, AND MAY VOID THE UL LISTING.



WARNING: DO NOT CONNECT THE AC INPUT POWER TO THE T1, T2, AND T3 OUTPUT TERMINALS. DOING THIS WILL DAMAGE THE AC DRIVE.



WARNING: DO NOT CONNECT SINGLE-PHASE POWER TO A THREE-PHASE DRIVE MODEL.



WARNING: TIGHTEN ALL SCREWS TO THE PROPER TORQUE RATING. SEE “MAIN CIRCUIT WIRING” LATER IN THIS CHAPTER.

WIRING NOTES: PLEASE READ PRIOR TO INSTALLATION.

- 1) During installation, follow all local electrical, construction, and safety codes for the country in which the AC drive is to be installed.
- 2) Refer to the “DURAPULSE GS20 & GS20X Drive Specifications” in chapter 1 for voltage and current requirements.
- 3) Torque the screws of the main circuit terminals to prevent loosening due to vibration.
- 4) The addition of a magnetic contactor (MC) in the AC line power input wiring is recommended to turn off power quickly and reduce the possibility of malfunction if the protection function of the GS20(X) AC drive is activated. Both ends of the MC should have an R-C surge absorber.
- 5) Do not use a power circuit contactor or disconnect switch for normal run/stop control of the GS20(X) AC drive and motor. This will reduce the operating life cycle of the AC drive. Cycling a power circuit switching device while the AC drive is in run mode should be done only in emergency situations.
- 6) Make sure the appropriate protective devices (circuit breaker or fuses) are connected between the power supply and AC drive.
- 7) Make sure that the leads are connected correctly and that the GS20(X) AC drive is properly grounded. (Ground resistance should not exceed 0.1Ω.)
- 8) Use ground leads that comply with AWG/MCM standards and keep them as short as possible.
- 9) Multiple GS20(X) AC drives can be installed in one location. All of the units should be grounded directly to a common ground terminal. The GS20(X) AC drive ground terminals may also be connected in parallel, as shown in the figure below.

Make sure there are no ground loops.

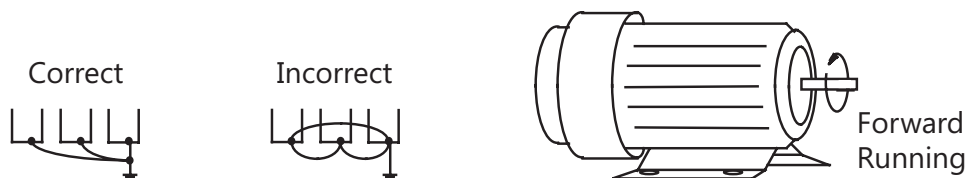

- 10) When the GS20(X) AC drive output terminals T1, T2, and T3 are connected to the motor terminals T1, T2, and T3, respectively, the motor will rotate counterclockwise (as viewed from the shaft end of the motor) when a forward operation command is received. To reverse the direction of motor rotation, switch the connections of any of the two motor leads.
- 11) Make sure that the power source is capable of supplying the correct voltage and required current to the GS20(X) AC drive.
- 12) Do not attach or remove wiring when power is applied to the GS20(X) AC drive.
- 13) Do not inspect components unless inside “POWER” lamp is turned off.
- 14) Do not monitor the signals on the circuit board while the GS20(X) AC drive is in operation.
- 15) Route the power and control wires separately, or at 90 degree angle to each other.

- 16) Ground both ends of the shield wire or conduit for the power wiring.
 - a) If using a “VFD cable,” follow the manufacturer’s recommendation for grounding the cable shield.
 - b) If using conduit, bond and ground conduit according to applicable electrical codes.
- 17) If a filter is required for reducing EMI (Electro Magnetic Interference), install it as close as possible to the GS20 AC drive input. EMI can also be reduced by lowering the Carrier Frequency. Please refer to the “Applied EMI/RFI Techniques” white paper at support.automationdirect.com.
- 18) If the GS20 AC drive is installed in a place where a load reactor is needed, install the reactor close to the T1, T2, and T3 side of GS20 AC drive. Do not use a Capacitor, L-C Filter (Inductance-Capacitance), or R-C Filter (Resistance-Capacitance).
- 19) When using a GFCI (Ground Fault Circuit Interrupt), select current sensor with sensitivity of 200mA or higher, and not less than 0.1-second operation time to avoid nuisance tripping.

MAIN POWER TERMINALS

- Do not supply GS20(X) 460 & 575 VAC models with single-phase power. R/L1, S/L2, and T/L3 have no phase-sequence requirement; they can be wired in any order.
- Do NOT start/stop the GS20(X) AC drive by turning input power ON/OFF. Start/stop the GS20(X) AC drive using RUN/STOP commands via control terminals or the keypad. If you must start/stop the GS20(X) AC drive by turning power ON/OFF, it is recommended to do so only ONCE per hour.

OUTPUT TERMINALS FOR MAIN CIRCUIT

- DO NOT connect phase-compensation capacitors or surge absorbers to the output terminals of the GS20(X) AC drive.
- Use a well-insulated motor suitable for inverter operation.

TERMINALS FOR CONNECTING DC REACTOR, EXTERNAL BRAKE RESISTOR, EXTERNAL BRAKE RESISTOR AND DC CIRCUIT

- Terminals +1 and +2 are used to connect an optional DC reactor or choke to improve power factor. From the factory, these terminals are connected with a short-circuit jumper. Remove this jumper before connecting a DC reactor. Note that not all GS20 drives include terminal +1.
- Tighten the jumper if a DC reactor is not connected and DC+ / +1 and +2/B1 terminals are used for common DC bus or brake resistors. This will prevent the AC motor drive from losing power and damage to the terminals. If the jumper is missing due to wiring, refer to the recommended main circuit terminal wire to short-circuit the DC+ / +1 and +2/B1 terminals.

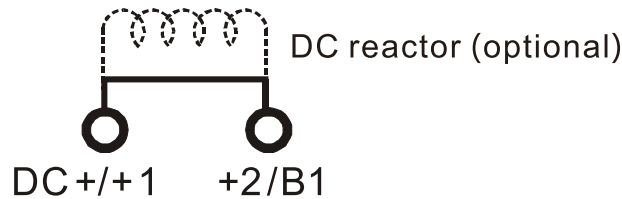

- When the GS20 AC Drive is connected directly to a large-capacity power transformer (600kVA or above) or when a phase lead capacitor is switched, peak currents may occur in the power input circuit due to the load change, resulting in damage to the converter section of the drive. To avoid this damage install a line reactor at the GS20 input terminals, R/L1, S/L2, and T/L3. The installation of a line reactor will reduce current and improve input power efficiency.
- Install an external brake resistor for applications in frequent deceleration to stop, short deceleration time (such as high frequency operation and heavy load operation), too low braking torque, or increased braking torque.

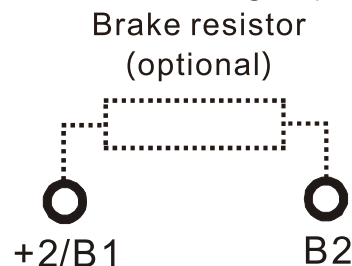

- For GS20(X) drives, the external brake resistor should be connected to the B1 and B2 terminals.
- If the terminals [+1], [+2], and [DC-] are not used, leave these three terminals open.
- To avoid personal injury and to prevent damage to the GS20 drive; DO NOT jumper DC- to DC+, DC- to +2/B1, DC- to B2. Connect braking resistors to B1 and B2 ONLY
- DC+ and DC- are connected for common DC bus, please refer to "[Main Circuit Wiring Terminals](#)" in this chapter for wiring terminal specification and wire gauge information.
- Please refer to the DURAPULSE Drives Dynamic Braking User Manual for more information on installing brake units.
(Available for free download at <http://www.automationdirect.com/static/manuals/index.html>.)

MOTOR OPERATION PRECAUTIONS

- 1) When using the GS20(X) AC drive to operate a standard 3-phase induction motor, notice that the energy loss is greater than for an inverter duty motor.
- 2) Avoid running a standard induction motor at low speed, which may cause the motor temperature to exceed the motor rating due to limited airflow produced by the motor's fan.
- 3) When the standard motor operates at low speed, the output load must be decreased.
- 4) If **100% output torque** is desired at low speed, it may be necessary to use a special "inverter-duty" rated motor.

SHORT CIRCUIT WITHSTAND (SCCR)

All DURAPULSE GS20(X) series drives are suitable for use on a circuit capable of delivering not more than 100,000 rms symmetrical amperes.

APPLICABLE CODES

All *DURAPULSE* GS20(X) AC drives are Underwriters Laboratories, Inc. (UL) and Canadian Underwriters Laboratories (cUL) listed, and therefore comply with the requirements of the National Electrical Code (NEC) and the Canadian Electrical Code (CEC).

Installations intended to meet the UL and cUL requirements must follow the instructions provided in “Wiring Notes” as a minimum standard. Follow all local codes that exceed UL and cUL requirements. Refer to the technical data label affixed to the AC drive and the motor nameplate for electrical data.

The “Circuit Protection Devices” section in Appendix A lists the recommended fuse part number for each *DURAPULSE* part number. These fuses (or equivalent) must be used on all installations where compliance with U.L. standards is required.

WIRING TERMINAL ACCESS

CONTROL TERMINAL ACCESS

Remove the drive front cover to access and wire the multi-function input/output control terminals.

GS20 DRIVE FRAMES A ~ F

Press the tabs on both sides to remove the cover.

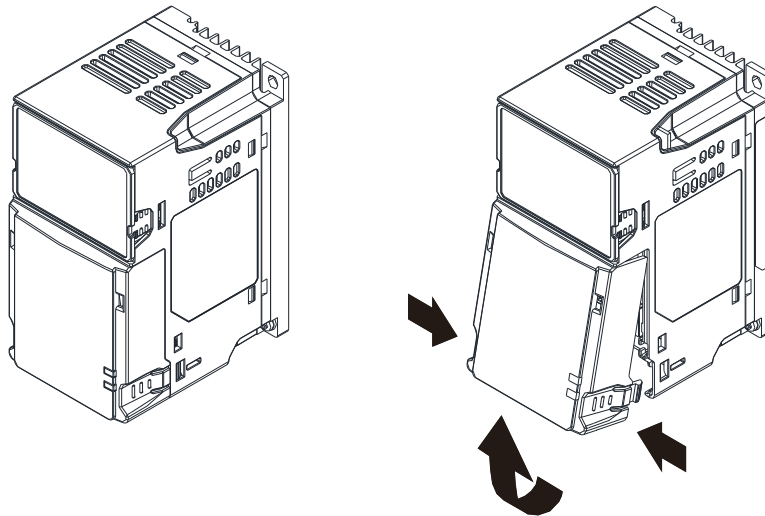

GS20X DRIVE FRAMES A ~ C

Loosen the four screws on the front cover and then open to the left.

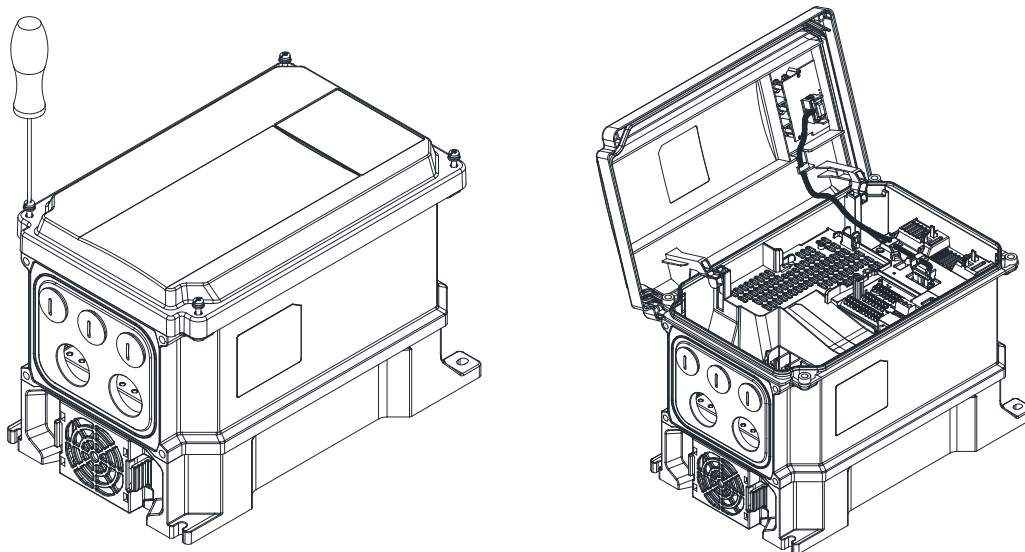

MAIN CIRCUIT WIRING TERMINALS

MAIN TERMINAL SPECIFICATIONS

Main Circuit Terminals	
Terminal	Description
R/L1, S/L2	Input Power – 1-phase
R/L1, S/L2, T/L3	Input Power – 3-phase
U/T1, V/T2, W/T3	AC Motor Drive Output
+1, +2 ¹	Connection for DC reactor (remove jumper before installing a DC reactor)
B1, B2	Braking Resistor Connection (optional)
DC+, DC- ¹	Common DC Bus
	Ground
<i>1 - DC- and DC +/+1 terminals are not available on 120V series drives.</i>	

GS20 Main Circuit Wiring Specifications							
AC Drive Frame Size	AC Drive Model	Main Circuit Terminals R/L1, S/L2, T/L3, U/T1, V/T2, W/T3, DC-, DC+/ ¹ , +2/B1, B2			Ground Terminals 		
		Max Wire Gauge	Min Wire Gauge	Screw Size & Torque (±10%)	Max Wire Gauge	Min Wire Gauge	Screw Size & Torque (±10%)
A	GS21-10P2	2.5 mm ² [14 AWG]	2.5 mm ² [14 AWG]	M3.5 9 kg-cm [7.8 in-lb] [0.88 N·m]	2.5 mm ² [14 AWG]	2.5 mm ² [14 AWG]	M3.5 9 kg-cm [7.8 in-lb] [0.88 N·m]
	GS21-10P5						
	GS21-20P5						
	GS23-21P0		1.5 mm ² [16 AWG]				
	GS21-20P2						
	GS23-20P2						
	GS23-20P5						
	GS23-40P5		0.75 mm ² [18 AWG]				
	GS23-41P0						
GS23-51P0							
B	GS21-21P0	4 mm ² [12 AWG]	4 mm ² [12 AWG]	M4 15 kg-cm [13.0 in-lb] [1.47 N·m]	4 mm ² [12 AWG]	4 mm ² [12 AWG]	M4 15 kg-cm [13.0 in-lb] [1.47 N·m]
	GS23-22P0						
	GS23-42P0		2.5 mm ² [14 AWG]		2.5 mm ² [14 AWG]		
	GS23-52P0		0.75 mm ² [18 AWG]		2.5 mm ² [14 AWG]		
C	GS21-11P0	10 mm ² [8 AWG]	10 mm ² [8 AWG]	M4 20 kg-cm [17.4 in-lb] [1.96 N·m]	10 mm ² [8 AWG]	10 mm ² [8 AWG]	M4 20 kg-cm [17.4 in-lb] [1.96 N·m]
	GS21-22P0						
	GS21-23P0						
	GS23-25P0						
	GS23-23P0		6 mm ² [10 AWG]		6 mm ² [10 AWG]		
	GS23-45P0		4 mm ² [12 AWG]		4 mm ² [12 AWG]		
	GS23-55P0						
	GS23-43P0		2.5 mm ² [14 AWG]		2.5 mm ² [14 AWG]		
GS23-53P0							
D	GS23-27P5	10 mm ² [8 AWG]	10 mm ² [8 AWG]	M4 20 kg-cm [17.4 in-lb] [1.96 N·m]	10 mm ² [8 AWG]	10 mm ² [8 AWG]	M4 20 kg-cm [17.4 in-lb] [1.96 N·m]
	GS23-40I0						
	GS23-47P5		6 mm ² [10 AWG]		6 mm ² [10 AWG]		
	GS23-57P5						
	GS23-50I0						
E	GS23-20I5	25 mm ² [4 AWG]	25 mm ² [4 AWG]	M5 25 kg-cm [21.7 in-lb] [2.45 N·m]	25 mm ² [4 AWG]	16 mm ² [6 AWG]	M5 25 kg-cm [21.7 in-lb] [2.45 N·m]
	GS23-20I0						
	GS23-40I5	16 mm ² [6 AWG]	16 mm ² [6 AWG]				
	GS23-40I0						
F	GS23-20I0	35 mm ² [2 AWG]	35 mm ² [2 AWG]	M6 40 kg-cm [34.7 in-lb] [3.92 N·m]	35 mm ² [2 AWG]	16 mm ² [6 AWG]	M6 40 kg-cm [34.7 in-lb] [3.92 N·m]
	GS23-40I0						
	GS23-40I5		25 mm ² [4 AWG]		25 mm ² [4 AWG]		



UL installations must use 600V, 75 °C or 90 °C wires. Use copper wire only.

GS20X Main Circuit Wiring Specifications							
AC Drive Frame Size	AC Drive Model	Main Circuit Terminals R/L1, S/L2, T/L3, U/T1, V/T2, W/T3, DC-, DC+ /+1, +2/B1, B2			Ground Terminals		
		Max Wire Gauge	Min Wire Gauge	Screw Size & Torque (±10%)	Max Wire Gauge	Min Wire Gauge	Screw Size & Torque (±10%)
A	GS21X-20P5	2.5 mm ² [14 AWG]	2.5 mm ² [14 AWG]	M3.5 9 kg-cm [7.8 in-lb] [0.88 N·m]	2.5 mm ² [14 AWG]	2.5 mm ² [14 AWG]	M4 20 kg-cm [17.4 in-lb] [1.96 N·m]
	GS23X-21P0		1.5 mm ² [16 AWG]				
	GS23X-20P5		0.75 mm ² [18 AWG]				
	GS23X-40P5						
	GS23X-41P0	4 mm ² [12 AWG]	4 mm ² [12 AWG]	4 mm ² [12 AWG]			
	GS21X-21P0		2.5 mm ² [14 AWG]	15 kg-cm [13.0 in-lb] [1.47 N·m]	2.5 mm ² [14 AWG]		
	GS23X-22P0			1.5 mm ² [16 AWG]	2.5 mm ² [14 AWG]		
	GS23X-42P0	6 mm ² [10 AWG]	6 mm ² [10 AWG]	M4 20 kg-cm [17.4 in-lb] [1.96 N·m]	6 mm ² [10 AWG]	6 mm ² [10 AWG]	
	GS21X-22P0		2.5 mm ² [14 AWG]	2.5 mm ² [14 AWG]			
GS23X-43P0	2.5 mm ² [14 AWG]	2.5 mm ² [14 AWG]					
B	GS21X-23P0	10 mm ² [8 AWG]	10 mm ² [8 AWG]	M4 20 kg-cm [17.4 in-lb] [1.96 N·m]	10 mm ² [8 AWG]	10 mm ² [8 AWG]	M4 20 kg-cm [17.4 in-lb] [1.96 N·m]
	GS23X-25P0		6 mm ² [10 AWG]		6 mm ² [10 AWG]		
	GS23X-23P0		4 mm ² [12 AWG]		4 mm ² [12 AWG]		
	GS23X-45P0		4 mm ² [12 AWG]		4 mm ² [12 AWG]		
C	GS23X-27P5	10 mm ² [8 AWG]	10 mm ² [8 AWG]	M4 20 kg-cm [17.4 in-lb] [1.96 N·m]	10 mm ² [8 AWG]	10 mm ² [8 AWG]	M4 20 kg-cm [17.4 in-lb] [1.96 N·m]
	GS23X-40I0		6 mm ² [10 AWG]		6 mm ² [10 AWG]		
	GS23X-47P5		6 mm ² [10 AWG]		6 mm ² [10 AWG]		

RECOMMENDED MODELS OR DIMENSIONS FOR FERRULE TERMINALS

Wire Gauge	Manufacturer	Model Name	A (MAX)	B (MAX)	D (MAX)	W (MAX)
0.25 mm ² [24 AWG]	PHOENIX CONTACT	AI 0,25- 8 YE	12.5	8	2.6	1.1
0.34 mm ² [22 AWG]	PHOENIX CONTACT	AI 0,34- 8 TQ	12.5	8	3.3	1.3
0.5 mm ² [20 AWG]	PHOENIX CONTACT	AI 0,5 - 8 WH	14	8	3.5	1.4
	Z+F	V30AE000006	14	8	2.6	1.15

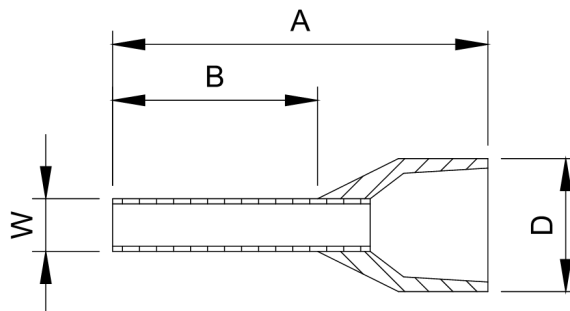

WIRING TERMINAL CONNECTOR DIMENSIONS – MAIN-CIRCUIT TERMINALS

DIMENSIONS = mm

GS20 DRIVES, FRAME SIZE A ~ F

NOTE: Heat shrink should comply with UL (600V, YDPU2).

Power Terminal Wiring Connectors:

Heat Shrink Tubing:

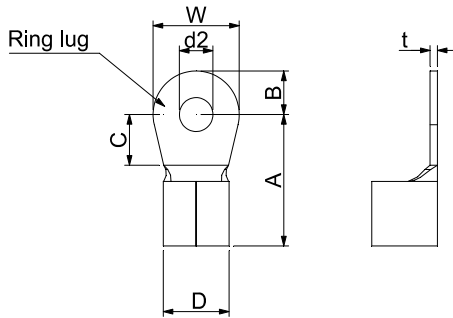

Figure 1.

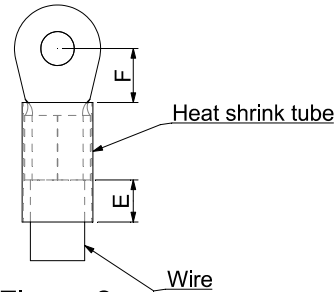

Figure 2.

GS20 Ring Lug Dimensions (mm)											
Frame	AWG	Part Number (Manuf: K.S. Terminals)	A (Max)	B (Max)	C (Min)	D (Max)	d2 (Min)	E (Min)	F (Min)	W (Max)	t (Max)
A	18	RNBS 1.3-7	9.8	3.2	4.8	4.1	3.7	13.0	4.2	6.6	0.8
	16	RNBS 2-3.7									
	14	RNBS 2-3.7									
B	18	RNBS1-4	12.1	3.6	6.1	5.6	4.3	13.0	4.5	7.2	1
	16	RNBS1-4									
	14	RNBS2-4									
C	12	RNBS5-4	17.8	5.0	6.1	7.2	4.3	13.0	5.5	10.5	1.2
	10	RNBS5-4									
	8	RNBS8-4									
D	10	RNBS5-4	17.8	5.0	6.1	7.2	4.3	13.0	5.5	10.5	1.2
	8	RNBS8-4									
E	6	RNBS8-4	27.1	6.1	10.5	11.5	5.3	13.0	6.5	12.6	1.7
	4	RNBS14-5									
F	6	RNBS14-6	35.0	9.0	13.3	14.0	6.2	13.0	10.0	19.5	1.8
	4	RNBS22-6									
	2	RNBS38-6									

GS20X DRIVES, FRAME SIZE A ~ C

NOTE: Heat shrink should comply with UL (600V, YDPU2).

Power Terminal Wiring Connectors:

Heat Shrink Tubing:

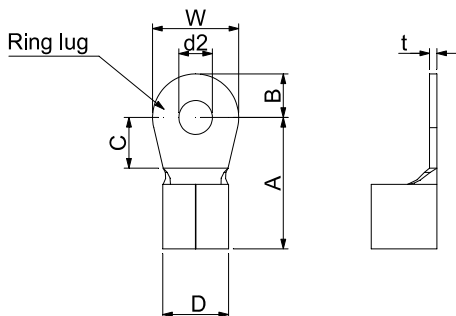

Figure 1.

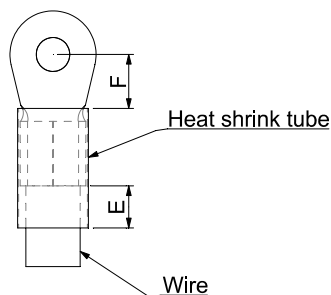

Figure 2.

GS20X Ring Lug Dimensions (mm)											
Frame	AWG	Part Number (Manuf: K.S. Terminals)	A (Max)	B (Max)	C (Min)	D (Max)	d2 (Min)	E (Min)	F (Min)	W (Max)	t (Max)
A	18	RNBS1-4	11.1	4.0	6.3	3.4	4.3	13.0	4.5	6.6	0.8
	16	RNBS1-4									
	14	RNBS2-4	12.1		6.1	5.6			5.5	7.2	1
	12	RNBS5-4									
B	10	RNBS5-4	17.8	5.0	6.1	7.2	4.3	13.0	5.5	8.0	1.2
	14	RNBS2-4									
	12	RNBS5-4									
	8	RNBS8-4									
C	10	RNBS5-4	17.8	5.0	6.1	7.2	4.3	13.0	5.5	8.0	1.2
	14	RNBS2-4									
	12	RNBS5-4									
	8	RNBS8-4									

MAIN TERMINAL DIAGRAMS



NOTE: DC- and DC+ /+1 terminals are not available on 120V series drives (Frame A and C).

GS20 FRAME SIZE A MAIN TERMINALS

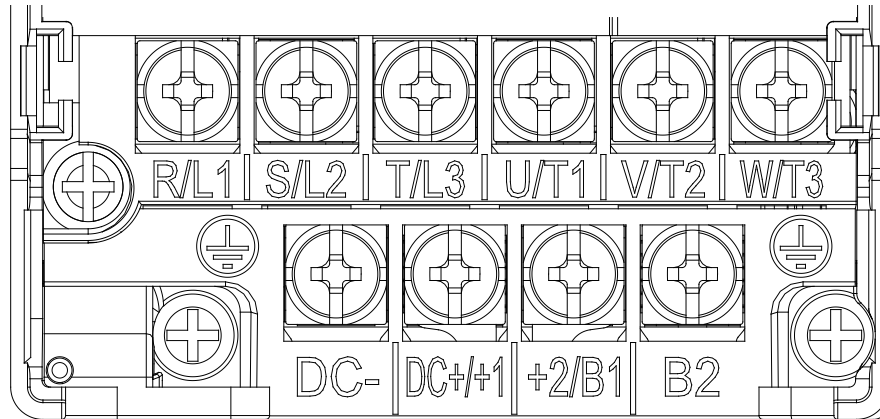

GS20 FRAME SIZE B MAIN TERMINALS

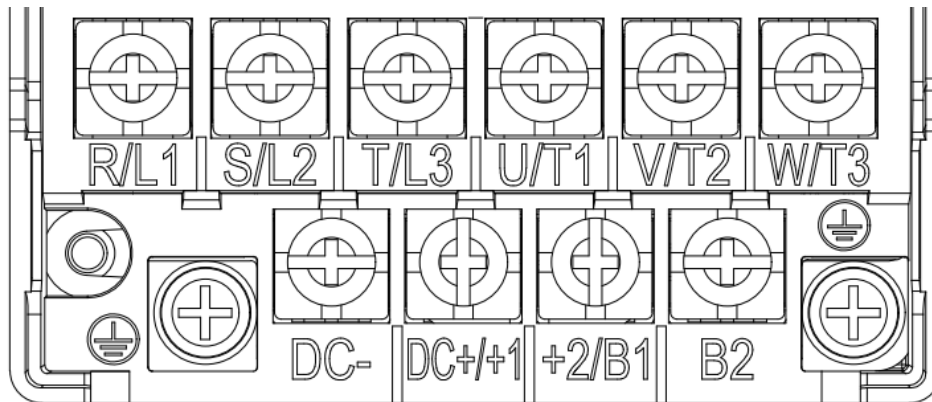

GS20 FRAME SIZE C MAIN TERMINALS

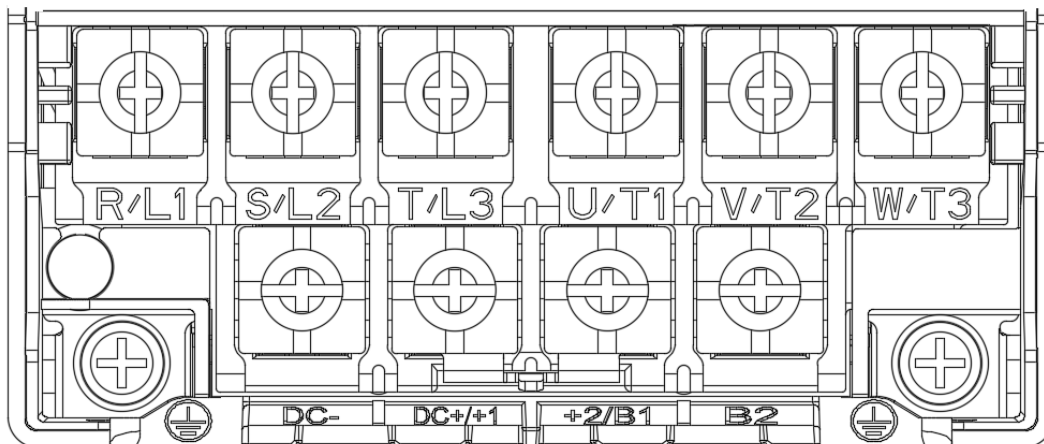

MAIN TERMINAL DIAGRAMS (CONTINUED)

GS20 FRAME SIZE D MAIN TERMINALS

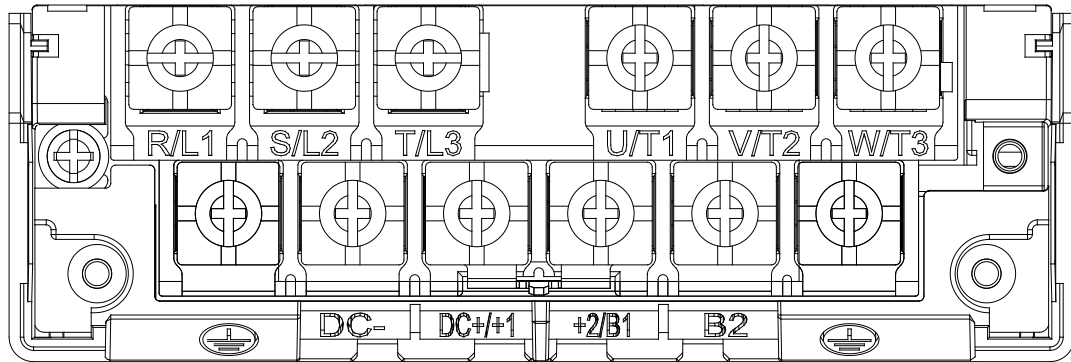

GS20 FRAME SIZE E MAIN TERMINALS

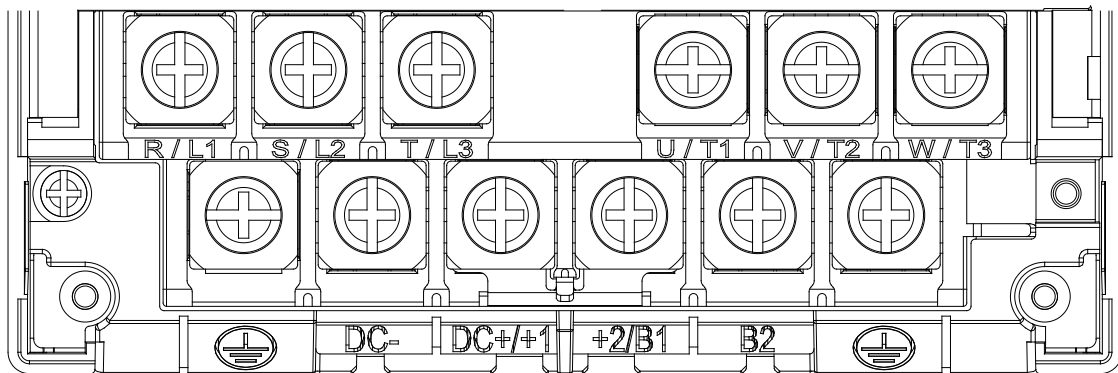

GS20 FRAME SIZE F MAIN TERMINALS

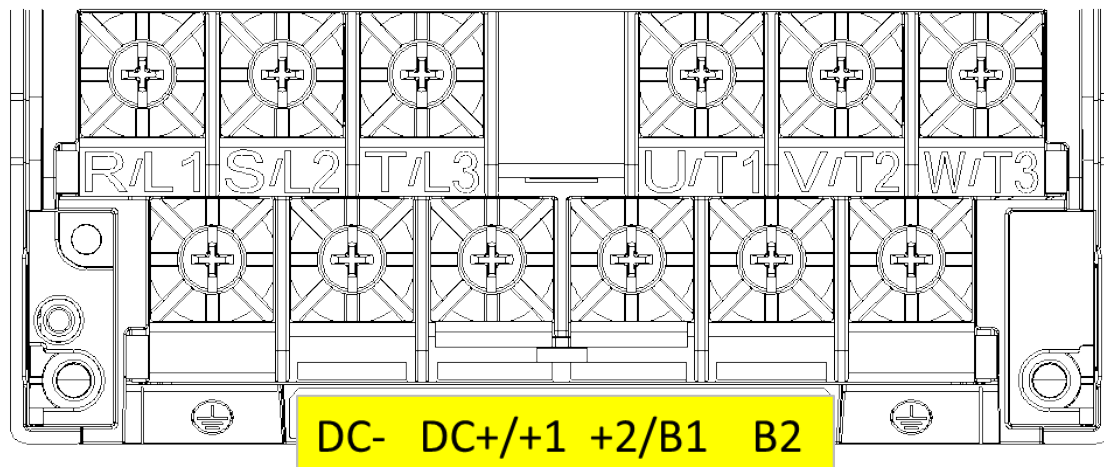

MAIN TERMINAL DIAGRAMS (CONTINUED)

GS20X FRAME SIZE A MAIN TERMINALS

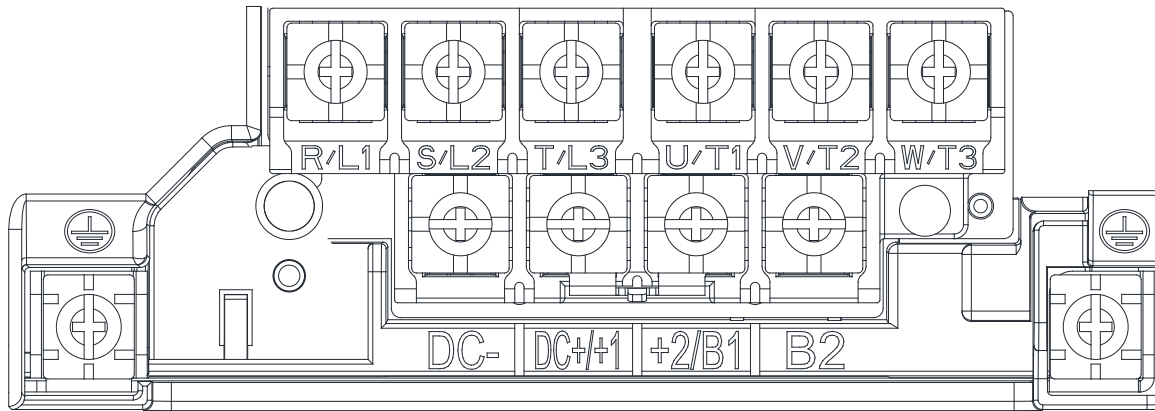

GS20X FRAME SIZE B MAIN TERMINALS

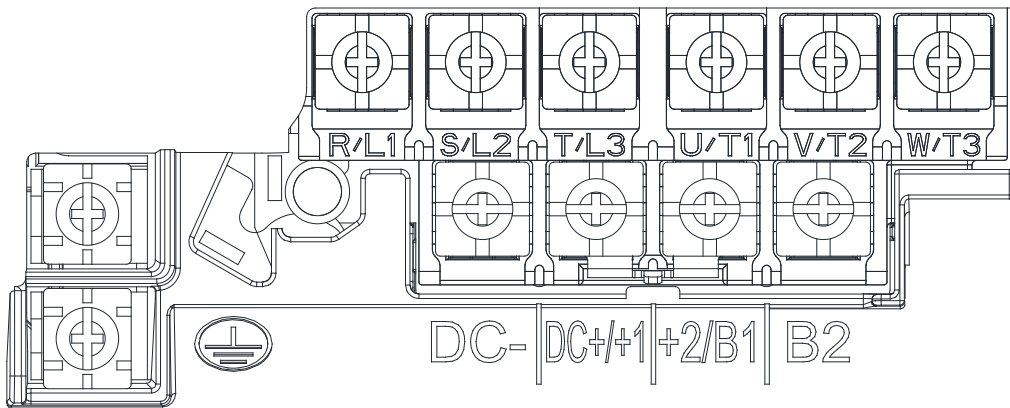

GS20X FRAME SIZE C MAIN TERMINALS

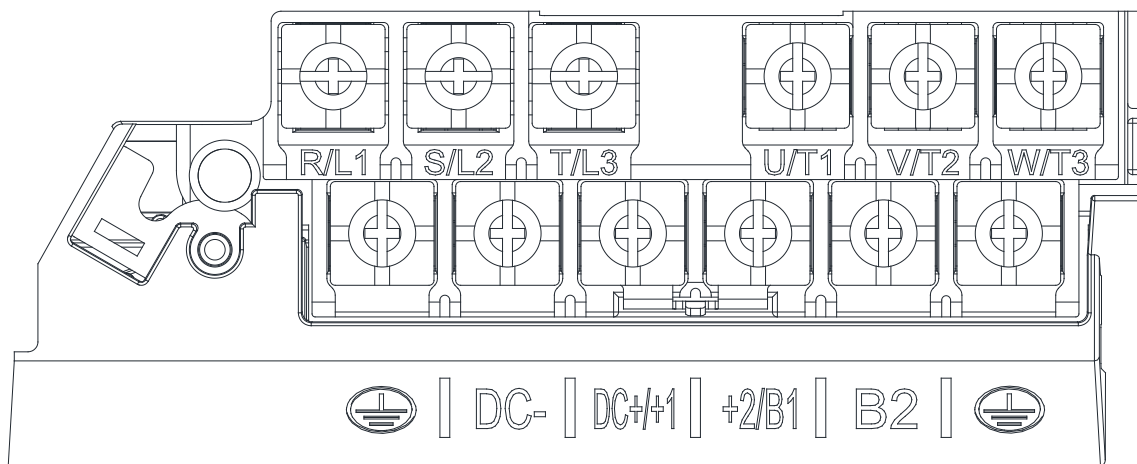

MAIN CIRCUIT WIRING DIAGRAMS

GS20 & GS20X ALL FRAME SIZES

Input 1-phase/3-phase power

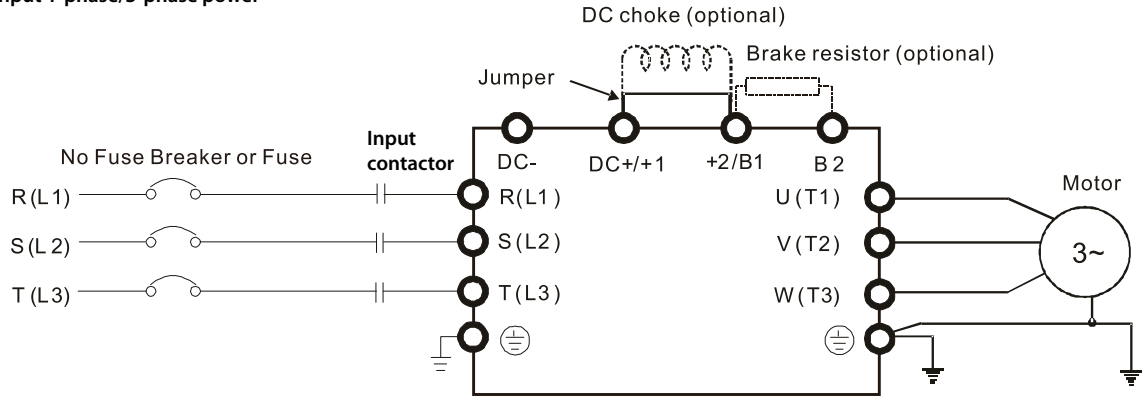

CONTROL CIRCUIT WIRING TERMINALS

GS20 & GS20X CONTROL TERMINAL SPECIFICATIONS

Control Circuit Terminals		
Terminal Symbol	Terminal Function	Description
+24V	Digital control signal common (Source)	+24V ± 10% 100 mA
FWD (DI1) REV (DI2) DI3 - DI7	Digital input 1-7 ① Sink Mode with internal power (+24 V _{DC}) See page 2-36 for sinking/sourcing wiring examples.	Source Mode: ON: activation current 3.3 mA ≥ 11 VDC OFF: cut-off voltage ≤ 5 VDC Sink Mode: ON: activation current 3.3 mA ≤ 13 VDC OFF: cut-off voltage ≥ 19 VDC DI7: Single pulse input, maximum input frequency=33kHz. Digital inputs can be configured by the user for many different functions. Refer to P02.01-P02.07 to program the digital inputs FWD (DI1), REV (DI2), DI3-DI7. <ul style="list-style-type: none"> When P02.00=0, FWD (DI1) and REV (DI2) can be programmed. When P02.00≠0, the functions of FWD (DI1) and REV (DI2) act according to P02.00 setting. When P02.07=0, DI7 is pulse input terminal. DI7 uses pulse input can be used as frequency command source or connect it to the encoder for motor closed-loop control. DI7 motor closed-loop control only supports VFPG control mode.
DO	Digital frequency signal output Max 30 V _{DC} 30 mA 	DO uses pulse voltage as an output monitoring signal; Duty-cycle: 50 % Min. load impedance RL: 1 kΩ / 100 pF Max. current endurance: 30 mA Max. voltage: 30 VDC ± 1 % (when 30 VDC / 30 mA / RL=100 pF) Max. output frequency: 33 kHz Current-limiting resistor R: ≥ 1 kΩ Output load impedance RL Capacitive load ≤ 100 pF
DCM	Digital control / Frequency signal common (Sink)	Resistive load ≥ 1 kΩ, resistance determines the output voltage value. DO-DCM voltage = external voltage * (RL / (RL+R))

(continued next page)

Control Circuit Terminals (continued)		
Terminal Symbol	Terminal Function	Description
DO1	Digital Output 1 (photo coupler)	<p>The AC motor drive outputs various monitoring signals, such as drive in operation, frequency reached, and overload indication through a transistor (open collector). These can be wired as sinking or sourcing (see Appendix D-3).</p> <p style="text-align: center;">Max 48 V_{DC} 50 mA</p>
DO2	Digital Output 2 (photo coupler)	
DOC	Digital Output Common (photo coupler)	
R10	Relay Output 1 (N.O.) a	<p>Resistive Load</p> <ul style="list-style-type: none"> • 3 A (N.O.) / 3 A (N.C.) 250 VAC • 5 A (N.O.) / 3 A (N.C.) 30 VDC <p>Inductive Load (COS 0.4)</p> <ul style="list-style-type: none"> • 1.2 A (N.O.) / 1.2 A (N.C.) 250 VAC • 2.0 A (N.O.) / 1.2 A (N.C.) 30 VDC <p>To output different kinds of monitoring signals such as motor drive in operation, frequency reached, and overload indication.</p>
R1C	Relay Output 1 (N.C.) b	
R1	Relay Output 1 Common	
+10V	Potentiometer power supply	Power supply for analog frequency setting: +10.5 ± 0.5 VDC / 20 mA
AI1	Analog voltage frequency command	<p>Circuit Impedance: 20kΩ Potentiometer Rating: 5kΩ (for full frequency range) Range: 0–10 V / -10–10 V = 0–Maximum Operation Frequency (P01.00) Mode switching by setting P03.00, P03.28 AI1 resolution=10 bits</p>
AI2	Analog current frequency command	<p>Impedance: Current mode=250 Ω, Voltage mode=20 kΩ Range: 0–20 mA / 4–20 mA / 0–10 V = 0–Maximum Operation Frequency (P01.00) Mode switching by setting P03.01, P03.29 Switch: The AI2 default is 0–20 mA / 4–20 mA (current mode) AI2 resolution = 12 bits</p>

(continued next page)

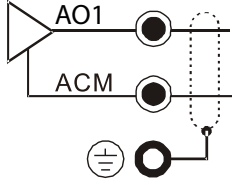
Control Circuit Terminals (continued)		
Terminal Symbol	Terminal Function	Description
AO1	Multi-function analog voltage output 	Switch: The AO1 default is 0–10 V (voltage mode). To switch to the current mode, two steps are required: 1) A dip switch must be configured (follow the instructions on the inner side of the front cover or see page 2–34). 2) Change P03.31 to 1 or 2 (see page 4–110). Voltage mode Range: 0–10 V (P03.31=0) corresponds to the maximum operating range of the control target Max. output current: 2 mA Max. Load: 5 kΩ Current mode Range: 0–20 mA (P03.31=1) / 4–20 mA (P03.31=2) corresponds to the maximum operating range of the control target, maximum load 500 Ω AO1 resolution=10 bits
ACM	Analog Signal Common	Analog signal common terminal
STO1, STO2	Default: STO1 / STO2 short-circuited to +24 V Rated voltage: 24 VDC ± 10 %; maximum voltage: 30 VDC ± 10 % Rated current: 6.67 mA ± 10 % STO activation mode Input voltage level: 0 VDC < STO1-SCM or STO2-SCM < 5 VDC STO response time ≤ 20 ms (STO1 / STO2 operates until the AC motor drive stops outputting current) STO cut-off mode Input voltage level: 11 VDC < STO1-SCM and STO2-SCM < 30 VDC Power removal safety function per EN 954-1 and IEC / EN 61508 Note: Refer to Appendix E SAFE TORQUE OFF FUNCTION for details.	
SG+	Modbus RS-485	
SG-	Note: Refer to Chapter 4, parameter group 09 Communication Parameters for details.	
SGND		
RJ45	PIN 1, 2, 6: Reserved PIN 3, 7: SGND PIN 4: SG- PIN 5: SG+ PIN 8: +10V supply GS4-KPD (provides (optional) power supply)	The RJ45 port provides a serial communications connection. Max Baud Rate = 115.2 kbps

GS20 & GS20X CONTROL TERMINAL BLOCK DIAGRAM & WIRING SPECIFICATIONS

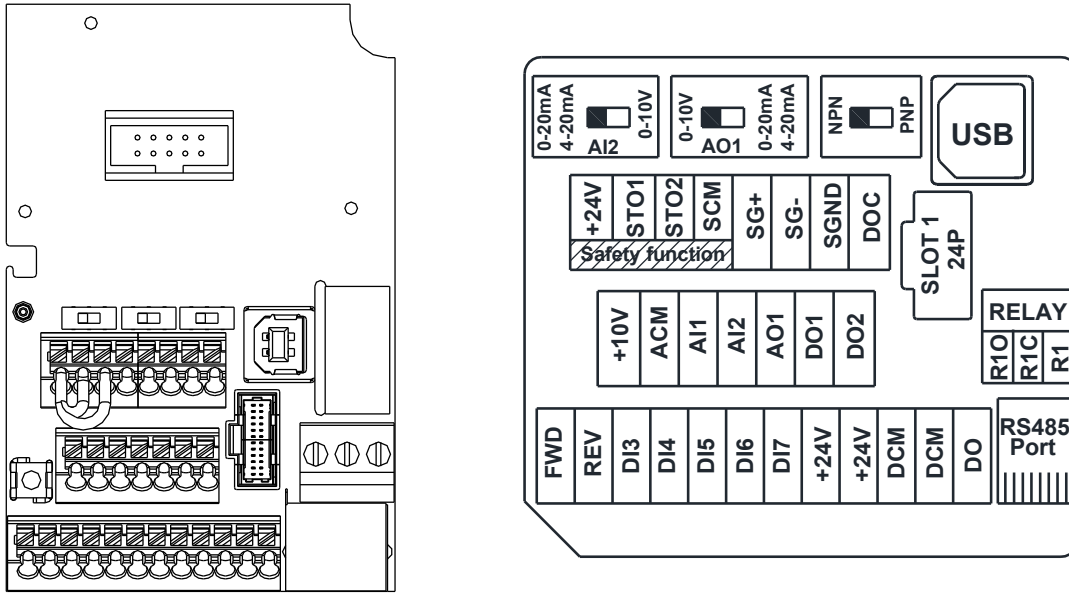

Wiring Specifications					
Terminal	Wiring Type	Stripping Length (mm)	Maximum Wire Gauge	Minimum Wire Gauge	Tightening Torque (kg-cm [lb-in])
Relay	Solid	6-7	1.31 mm ² (16 AWG)	0.21 mm ² (24 AWG)	5 kg-cm (4.3 lb-in)
	Strand				
Control	Solid	9	0.82 mm ² (18 AWG)	0.21 mm ² (24 AWG)	n/a (spring terminals)
	Strand				
	Stranded with ferrules with plastic sleeves				

CONTROL TERMINAL WIRING INSTRUCTIONS

DIGITAL INPUTS

- When using contacts or switches to control the digital inputs, use high quality components to avoid contact bounce.

Wiring Multiple Drives Together – Digital Inputs

- With drive Digital Inputs in SINKING mode: When connecting a single device to the Digital Inputs of multiple drives (Run, Stop, Reverse, etc.), the DCM (Digital Signal Common) terminals from each drive should be connected together. [Otherwise, do NOT connect the different drive DCM terminals together if the drive DI are sourcing.]
- With drive Digital Inputs in SOURCING mode (and the connected field devices are sinking): Do NOT connect the different drive DCM terminals together. [If the DCM terminals of multiple drives are connected together with the drive DI in sourcing mode, the inputs of some of the drives may inadvertently turn ON if another drive is powered OFF.]

EXAMPLE: A switch is tied to Digital Input 1 of Drives A, B, C, and D. The Drive inputs are all set to Source current out to the field devices. If Drives A, B and C lose power, their Digital Inputs may sink enough current to inadvertently turn ON Digital Input 1 on Drive D.



WARNING: WITH DRIVE DIGITAL INPUTS IN SOURCING MODE
Do NOT CONNECT THE DIFFERENT DRIVE DCM TERMINALS TOGETHER.

ANALOG INPUTS

- Analog input signals are easily affected by external noise. Use shielded wiring and keep it as short as possible (<20m) with proper grounding. If the noise is inductive, connect the shield to terminal ACM.
- Use twisted-pair wire
- If the analog input signals are affected by noise from the AC motor drive, please connect a capacitor and ferrite core as indicated in the diagram at right.
(WIND EACH WIRE AROUND THE CORE 3 TIMES OR MORE.)

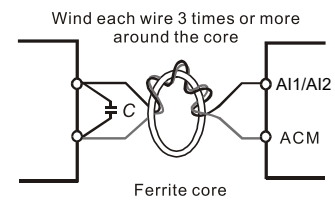

CONTROL TERMINAL WIRING INSTRUCTIONS (CONTINUED)

TRANSISTOR OUTPUTS (DO1, DO2, DOC)

- Make sure to connect the digital outputs to the correct polarity.
- When connecting a relay to the digital outputs, connect a surge absorber across the coil and check the polarity.

ANALOG OUTPUT

- When setting dip switch AO1 and using it as a current source, ensure P03.31 AO1 0~20mA/4~20mA selection is set appropriately.

PT100

PT100 RTD circuits should be wired and configured as follows:

- Set P03.00 = 1 (PT100 input)
- If using AI2, set dip switch to 0-10V, set P03.01=11, and P03.29=1.

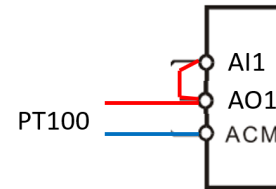

CONTROL CIRCUIT WIRING DIAGRAMS

DIGITAL INPUTS

① Sink Mode with internal power (+24 V_{DC})

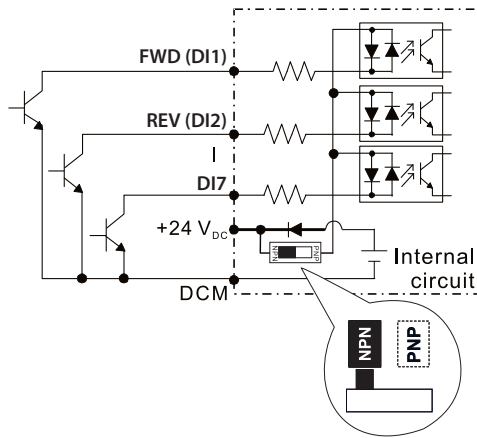

② Source Mode with internal power (+24 V_{DC})

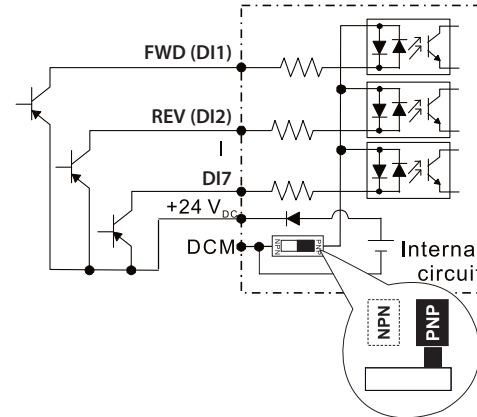

③ Sink Mode with external power

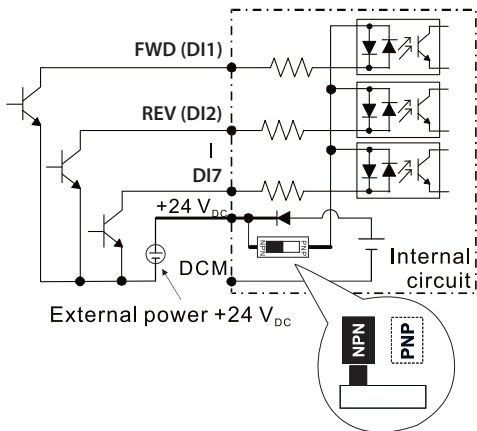

④ Source Mode with external power

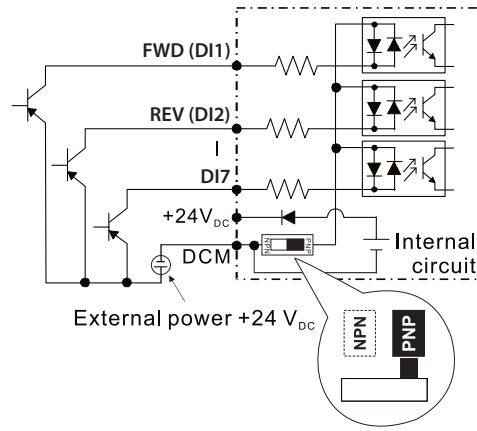

CONTROL CIRCUIT WIRING DIAGRAMS (CONTINUED)

SYSTEM WIRING DIAGRAM

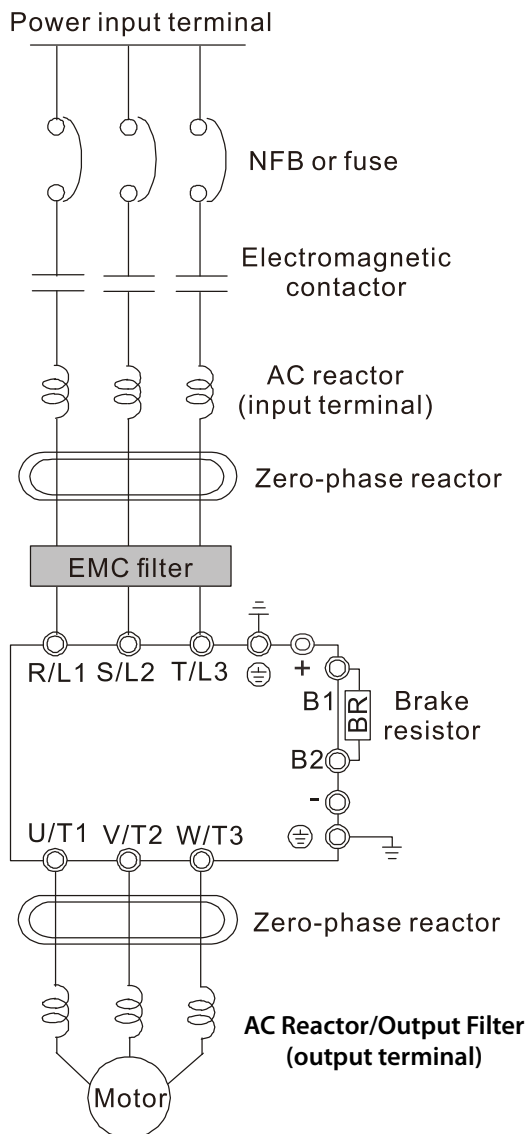

System Wiring Components	
Component	Function
Power input terminal	Supply power according to the rated power specifications indicated in the manual
NFB or fuse	There may be a large inrush current during power on. Select a suitable NFB (Non Fuse Breaker or Circuit Breaker) or Fuse.
Electromagnetic contactor	Switching the power ON/OFF on the primary side of the electromagnetic contactor can turn the drive ON/OFF, but frequent switching can cause machine failure. Do not switch ON/OFF more than once an hour. Do not use the electromagnetic contactor as the power switch for the drive; doing so shortens the life of the drive.
AC reactor (input terminal)	When the main power supply capacity is greater than 500 kVA, or when it switches into the phase capacitor, the instantaneous peak voltage and current generated may destroy the internal circuit of the drive. It is recommended that you install an input side AC reactor in the drive. This also improves the power factor and reduces power harmonics. The wiring distance should be within 10 m.
Zero phase reactor	Used to reduce radiated interference, especially in environments with audio devices, and reduce input and output side interference. The effective range is AM band to 10 MHz.
EMC filter	Can be used to reduce electromagnetic interference.
Brake module and Brake resistor (BR)	Used to shorten the deceleration time of the motor.
AC reactor or Filter (output terminal)	The motor cable length affects the size of the reflected wave on the motor end. For motor distances greater than 100 feet, the VTF series dV/dT filter is recommended.

CONTROL CIRCUIT WIRING DIAGRAMS (CONTINUED)

FULL I/O WIRING DIAGRAM

