

proense®



Operating instructions
Magnetic-inductive flow meter

FMM150-1002

FMM200-1002

80229912 / 00 08 / 2015

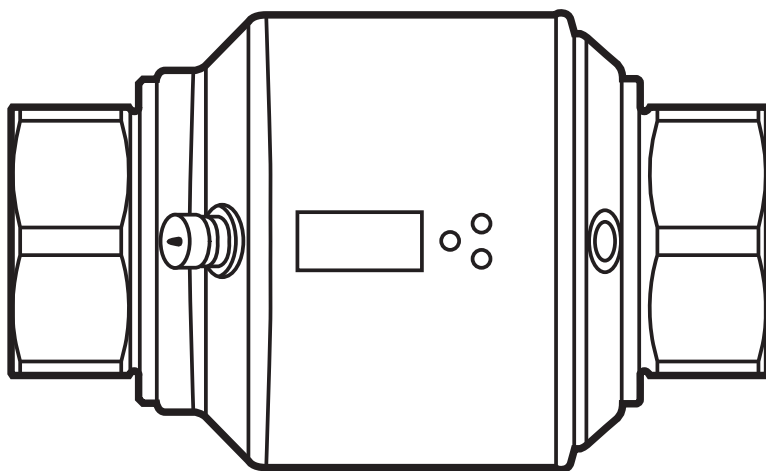

by Automationdirect.com

Contents

| | | |
|--------|---|----|
| 1 | Preliminary note..... | 4 |
| 1.1 | Symbols used | 4 |
| 1.2 | Warning signs used | 4 |
| 2 | Safety instructions | 4 |
| 3 | Functions and features | 6 |
| 4 | Function | 6 |
| 4.1 | Measuring principle for flow rate monitoring | 6 |
| 4.2 | Processing of the measured signals..... | 7 |
| 4.3 | Flow rate measurement | 7 |
| 4.4 | Temperature monitoring..... | 7 |
| 4.5 | Empty pipe detection | 8 |
| 4.6 | Flow rate or temperature monitoring / analog function | 8 |
| 4.7 | Low flow cut-off (LFC)..... | 9 |
| 4.8 | Simulation | 9 |
| 5 | Installation..... | 10 |
| 5.1 | Recommended installation locations | 10 |
| 5.2 | Not recommended installation position..... | 12 |
| 5.3 | Grounding..... | 13 |
| 6 | Electrical connection..... | 13 |
| 7 | Operating and display elements | 14 |
| 8 | Menu..... | 15 |
| 8.1 | Process value display | 15 |
| 8.2 | Main menu, Extended functions | 16 |
| 8.3 | Basic settings | 18 |
| 8.4 | Min/max memory – Empty pipe – Simulation | 20 |
| 8.5 | Explanation simulation (SIM)..... | 21 |
| 9 | Set-up | 21 |
| 10 | Parameter setting | 22 |
| 10.1 | Parameter setting in general | 23 |
| 10.1.1 | Switching between the menu levels | 24 |
| 10.1.2 | Locking / unlocking | 24 |
| 10.1.3 | Timeout..... | 24 |

| | | |
|---------|---|----|
| 10.2 | Setting the analog value for temperature | 24 |
| 10.3 | Setting the analog value for flow rate | 24 |
| 10.4 | User settings (optional)..... | 25 |
| 10.4.1 | Setting of the standard unit of measurement for temperature | 25 |
| 10.4.2 | Setting of the standard unit of measurement for flow rate..... | 25 |
| 10.4.3 | Configuration of the standard display | 25 |
| 10.4.4 | Changing the direction of the flow rate measurement..... | 25 |
| 10.4.5 | Setting of measured value damping | 25 |
| 10.4.6 | Setting of the error behaviour of the outputs | 25 |
| 10.4.7 | Activating / deactivating empty pipe detection..... | 26 |
| 10.4.8 | Time-delay empty pipe detection..... | 26 |
| 10.4.9 | Setting of the empty pipe detection | 26 |
| 10.4.10 | Setting of the low flow cut-off..... | 26 |
| 10.5 | Service functions | 26 |
| 10.5.1 | Reading the min/max values for the flow rate | 26 |
| 10.5.2 | Reading the min/max values for the temperature..... | 27 |
| 10.5.3 | Simulation menu..... | 27 |
| 10.5.4 | Resetting all parameters to factory setting | 27 |
| 10.5.5 | IO-L Parameter | 27 |
| 11 | Operation | 28 |
| 11.1 | Reading the process value | 28 |
| 11.2 | Reading the parameter value..... | 28 |
| 11.3 | Error indications | 29 |
| 12 | Technical data..... | 29 |
| 13 | Factory setting | 30 |

1 Preliminary note

1.1 Symbols used

- ▶ Instruction
- > Reaction, result
- [...] Designation of keys, buttons or indications
- Cross-reference



Important note

Non-compliance can result in malfunction or interference.



Information

Supplementary note.

1.2 Warning signs used

CAUTION

Warning of personal injury. Slight reversible injuries may result.

2 Safety instructions

- Please read this document prior to set-up of the unit. Ensure that the product is suitable for your application without any restrictions.
- If the operating instructions or the technical data are not adhered to, personal injury and/or damage to property can occur.
- Improper or non-intended use may lead to malfunctions of the unit or to unwanted effects in your application. That is why installation, electrical connection, set-up, operation and maintenance of the unit must only be carried out by qualified personnel authorized by the machine operator.
- In order to guarantee the correct condition of the device for the operating time the device must only be used in media to which the wetted parts are sufficiently resistant (→ Technical data).
- The responsibility to determine whether the measurement devices are suitable for the respective application lies with the operator. The manufacturer assumes no liability for consequences of misuse by the operator. Improper installation and use of the devices result in a loss of the warranty claims.

- For medium temperatures above 122 °F some parts of the housing can heat up to over 149 °F. Moreover, during installation or in case of a fault (e.g. housing damage) media under high pressure or hot media can leak from the system. To avoid personal injury, take the following measures:
 - ▶ Install the unit according to the applicable rules and regulations.
 - ▶ Ensure that the system is free of pressure during installation.
 - ▶ Protect the housing against contact with flammable substances and unintentional contact. To do so, equip the unit with suitable protection (e.g. protective cover).
 - ▶ Do not press the pushbuttons manually; instead use another object (e.g. ballpoint pen).

3 Functions and features

The unit monitors liquid media.

The unit detects the process categories flow rate and medium temperature.

 Pressure Equipment Directive (PED):
The units comply with the Pressure Equipment Directive and are designed and manufactured for group 2 fluids in accordance with the sound engineering practice. Use of group 1 fluids on request.

Application area

Conductive liquids with the following properties:

- Conductivity: $\geq 20 \mu\text{S/cm}$
- Viscosity: $< 70 \text{ cST at } 40^\circ\text{C} / 104^\circ\text{F}$

4 Function

4.1 Measuring principle for flow rate monitoring

The magnetic-inductive measuring principle means that a magnetic field is generated in the measuring pipe via current-carrying coils. When a conductive medium flows through the measuring pipe, the ions therein are diverted perpendicularly to the magnetic field. Positive and negative charge carriers flow in opposite directions. The voltage induced is measured by two electrodes that are in contact with the medium. This signal voltage is directly proportional to the average flow velocity. The flow rate is derived from the internal pipe diameter.

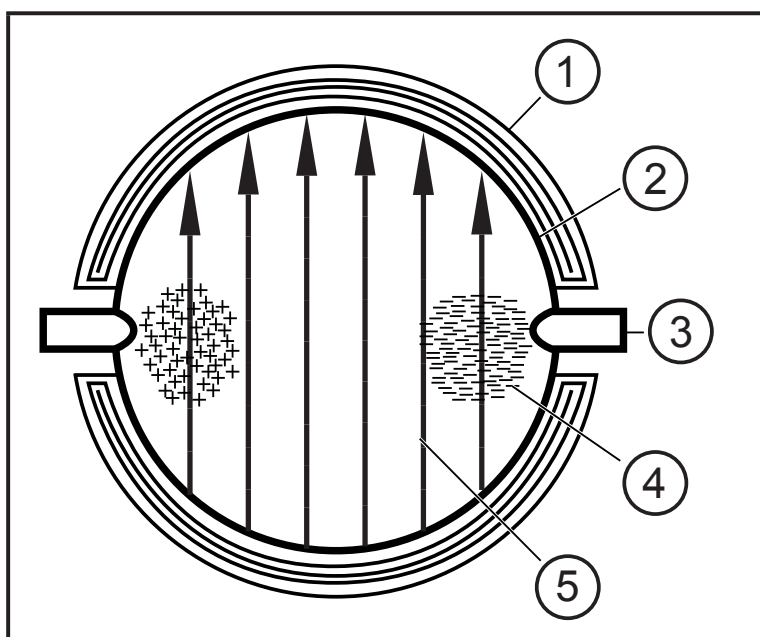

- 1: Field coil
- 2: Measuring pipe
- 3: Electrode
- 4: Charge carrier in the medium
- 5: Magnetic field



Both electrodes must be wetted by the medium. Otherwise the signal [SEnS] for empty pipe is provided, if empty pipe detection is enabled.

4.2 Processing of the measured signals

The unit displays the current process values.

It generates 2 output signals according to the parameter setting.

OUT1: Parameter setting
- Analog signal for temperature (→ 10.2)

OUT2: Parameter setting
- Analog signal for flow rate (→ 10.3)

4.3 Flow rate measurement

An analog signal which is proportional to the flow rate (4...20 mA) is provided on output 2 in case of medium flow in the measuring pipe. (On the analog functions → 4.6)

In addition to the flow rate, the unit also detects the flow direction. An arrow on the unit indicates the positive flow direction.

The flow direction can be inversed (→ 10.4.4).



► Use the supplied label to mark the changed flow direction.

Direction of flow corresponds to "flow direction"

> process value and display positive.

Direction of flow against "flow direction"

> process value and display negative.



Only positive process values are processed for the signal output.

4.4 Temperature monitoring

An analog signal (4...20 mA) can be provided on output 1 for temperature monitoring. On the analog functions → 4.6.

4.5 Empty pipe detection

The unit detects when the two electrodes are not wetted by the medium (→ 4.1 Measuring principle for flow rate monitoring). The empty pipe detection can be activated or deactivated (→ 10.4.7). If it is active and the pipe is empty, the unit reacts as follows:

- > [SEnS] is indicated in the display.
- > The flow is set to zero.

The empty pipe detection can be set as time-dependent or not time dependent (→ 10.4.8).

4.6 Flow rate or temperature monitoring / analog function

Current output

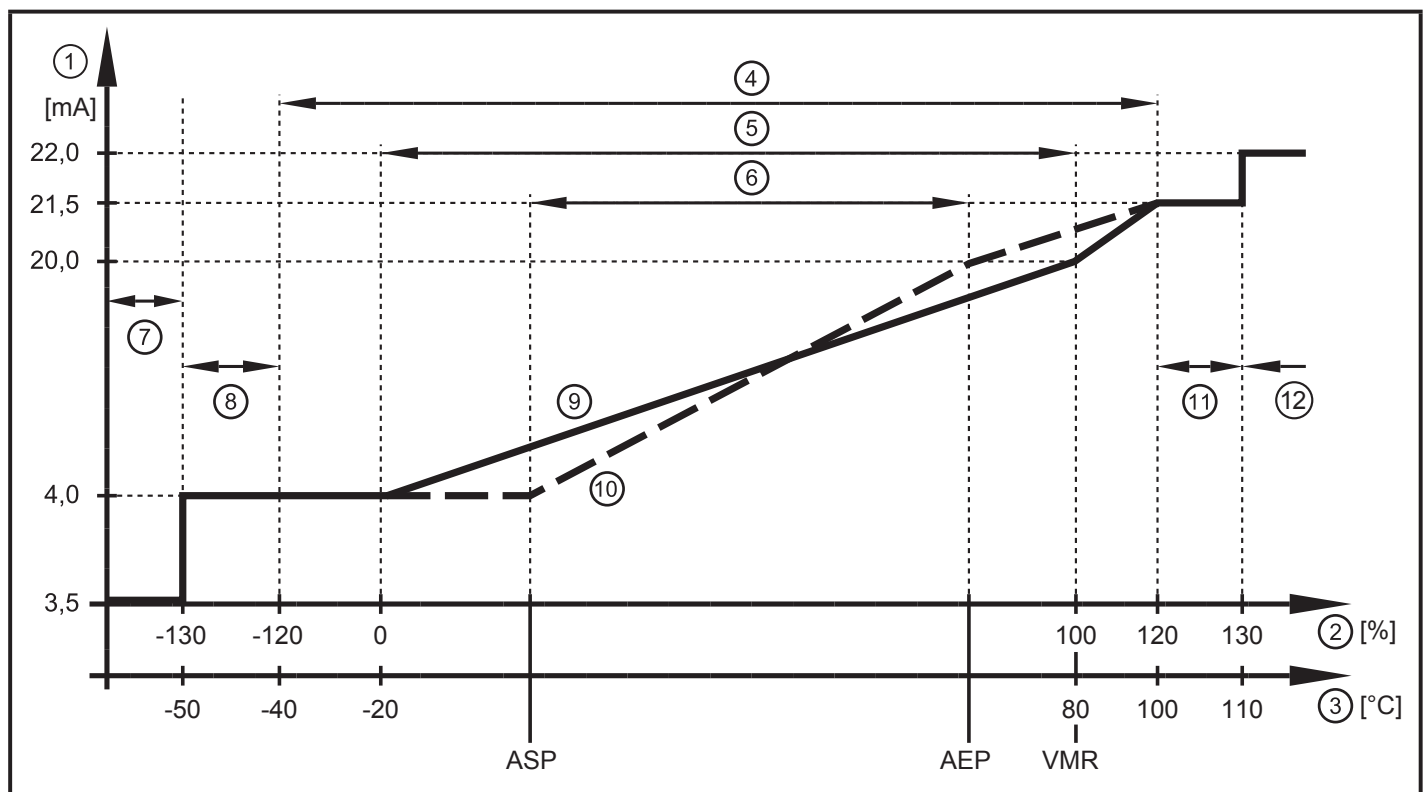

Characteristics of the analog output according to the standard IEC 60947-5-7

- 1: Output current
- 2: Flow rate
- 3: Temperature
- 4: Display range
- 5: Measuring range
- 6: Range between analog start point and analog end point
- 7: The unit is in the error state (FOU = OFF)
- 8: The process value transmitted in an analog way is therefore below the display range
- 9: Curve of the analog signal at factory setting

10: Curve of the analog signal with shifted ASP and AEP

11: The process value transmitted in an analog way is therefore above the display range

12: The unit is in the error state (FOU = ON).

ASP = analog start point: determines at which measured value the output signal is 4 mA.

AEP = analog end point: determines at which measured value the output signal is 20 mA.

VMR = final value of the measuring range = 100 %



Minimum distance between ASP and AEP = 20 % of the measuring range.

In the set scaling range the output signal is between 4 and 20 mA.

4.7 Low flow cut-off (LFC)

With this function small flow rates can be ignored (→ 10.4.10). Flows below the LFC value are evaluated by the sensor as standstill ($Q = 0$).

4.8 Simulation

With this function flow and temperature values can be simulated. (→ 10.5.3). The outputs operate as previously set.

5 Installation



► Avoid deposits, accumulated gas and air in the pipe system.

5.1 Recommended installation locations

Example of an optimized installation:

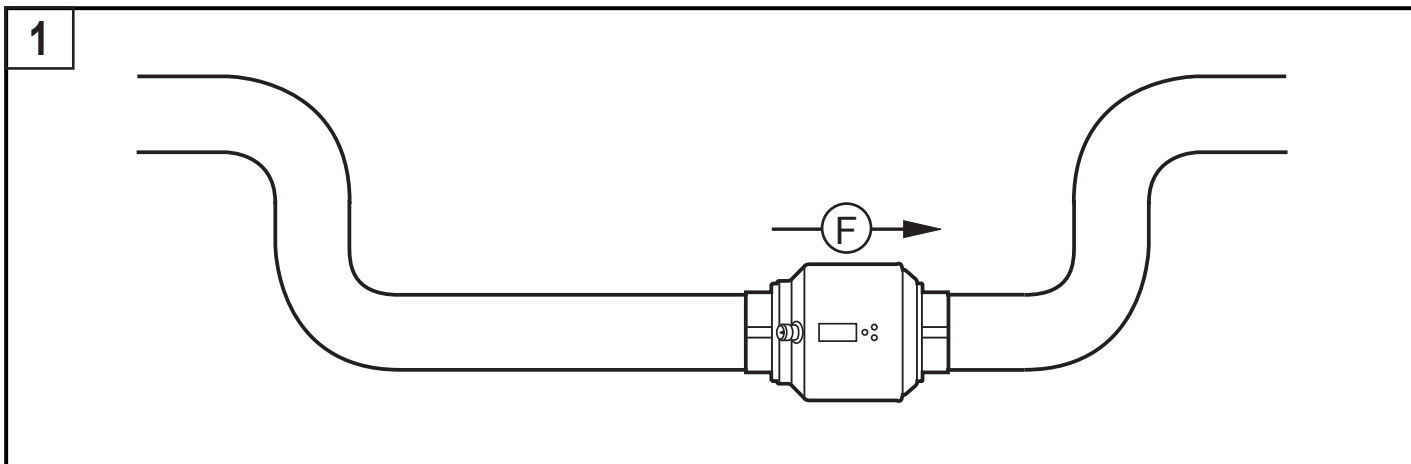

- Install the unit so that the measuring pipe is completely filled.
- Arrange for inlet and outlet pipe lengths. Disturbances caused by bends, valves, reductions, etc. are compensated for. It applies in particular: No shut-off and control devices are allowed directly in front of the unit.

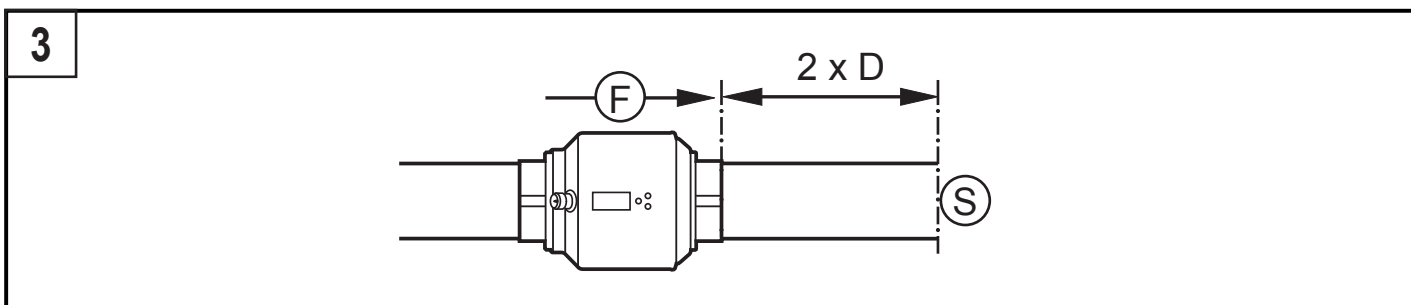
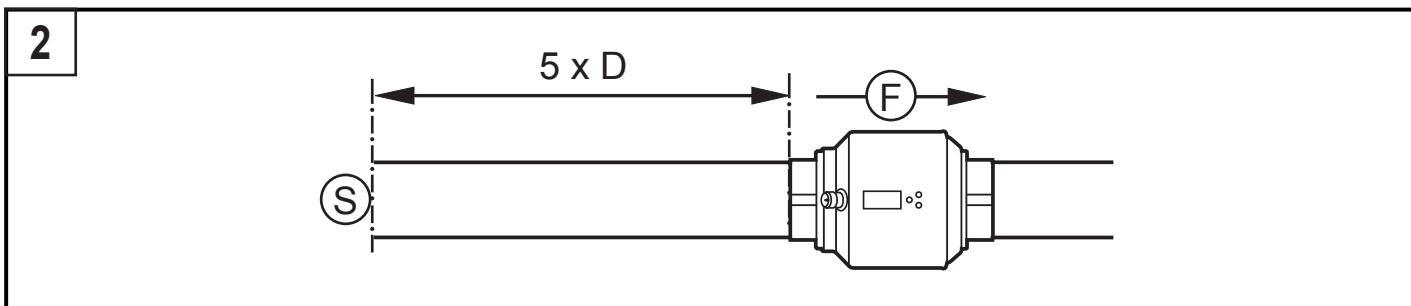

S = disturbance; D = pipe diameter; F = flow direction

► Install in front of or in a rising pipe:

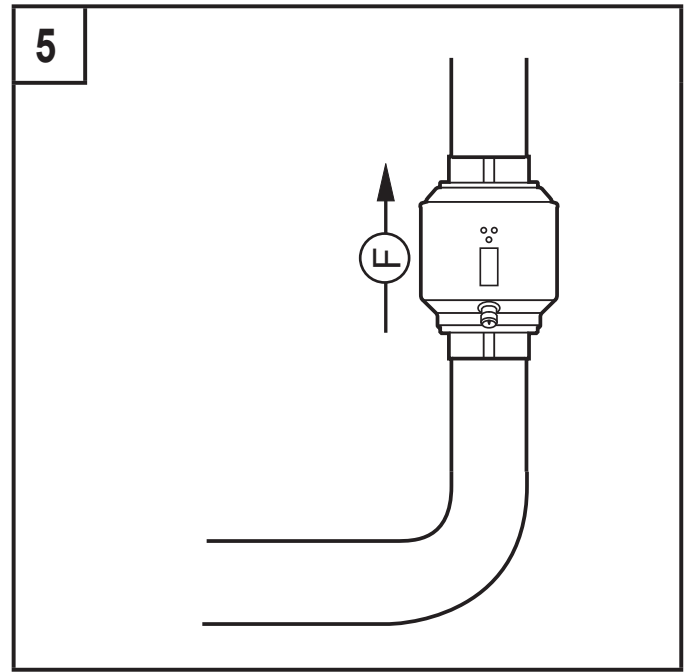
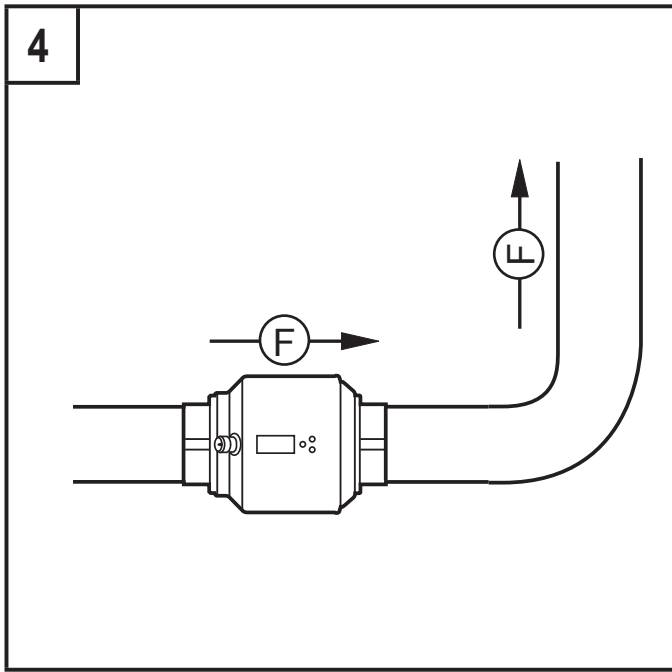

F = flow direction



With empty pipe detection:

► Install the unit according to figure 1, 4 or 5.



The unit can be installed irrespective of the orientation if the following is ensured:

- No air bubbles can form in the pipe system.
- The pipes are always completely filled.

5.2 Not recommended installation position

► Avoid the following installation positions:

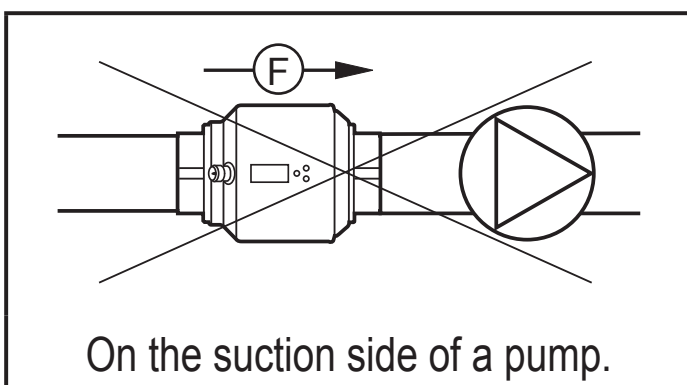
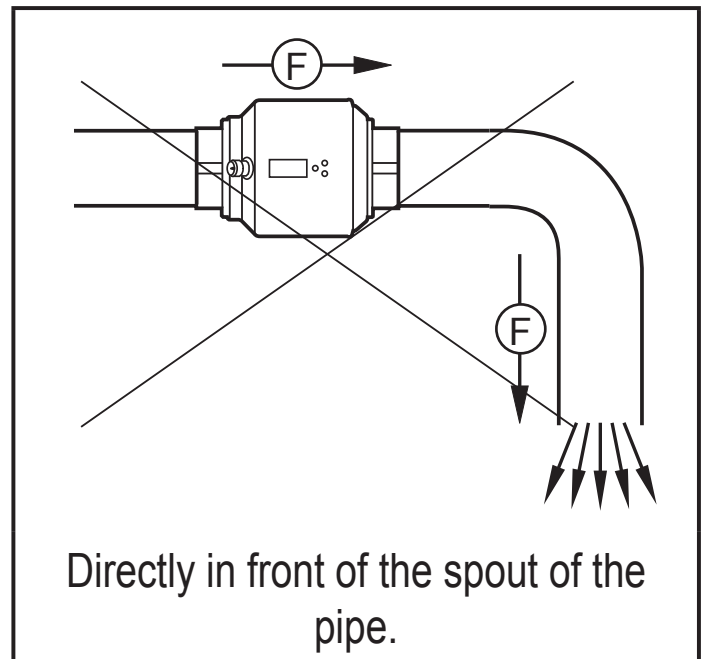
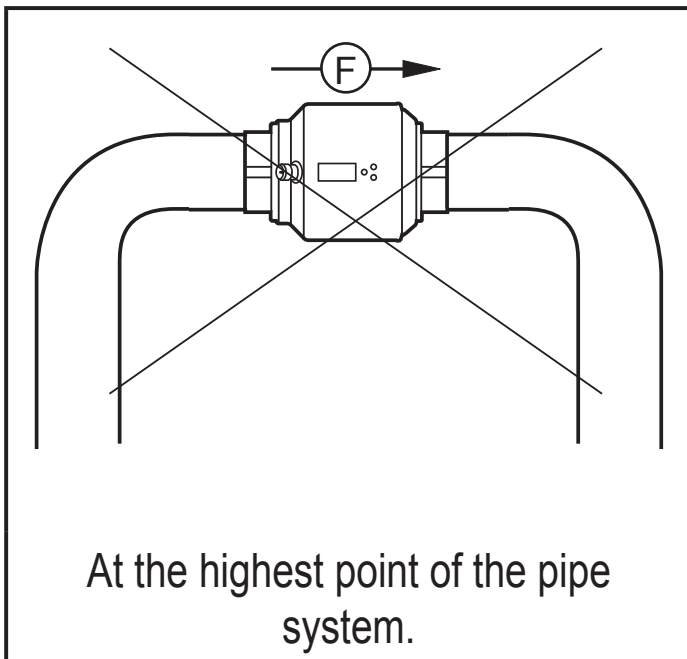
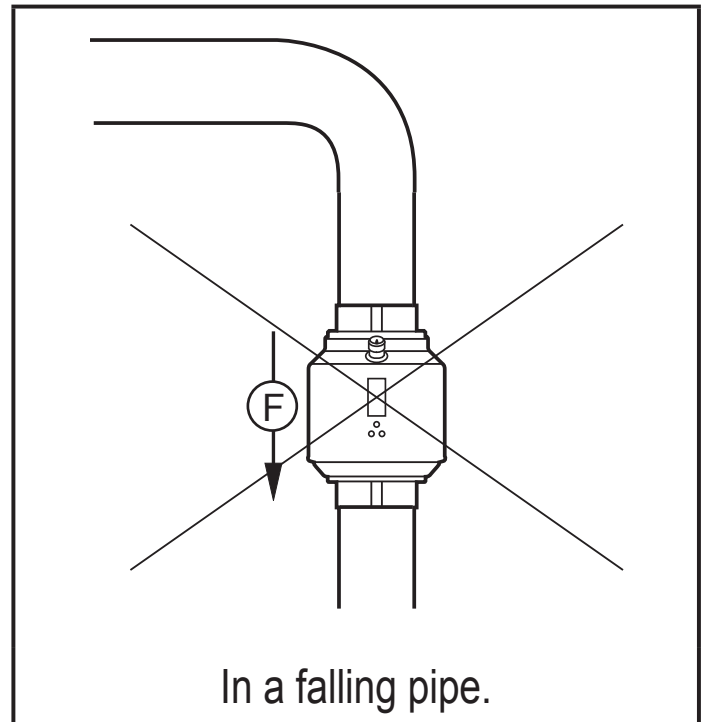
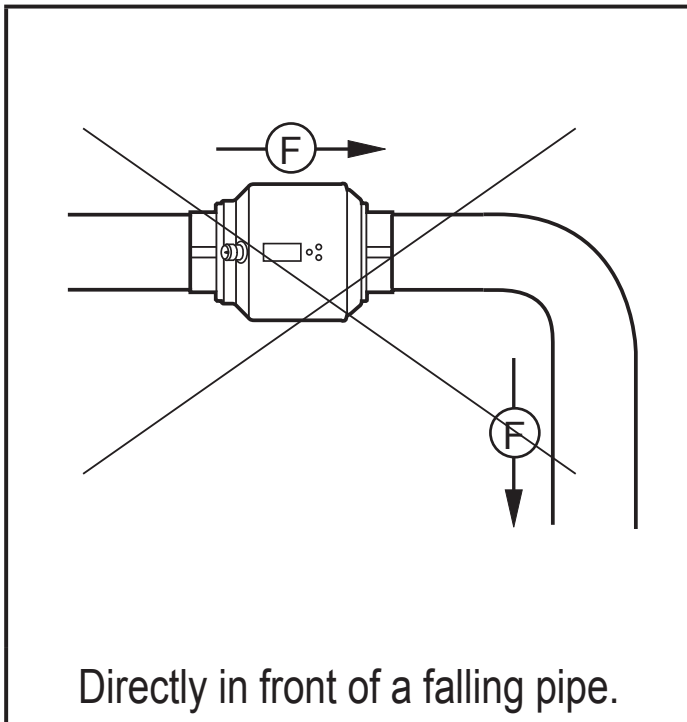

F = flow direction

5.3 Grounding



If installed in an ungrounded pipe system (e.g. plastic pipes), the unit must be grounded (functional earth).

Ground brackets for the M12 connector are available as accessories (→ www.automationdirect.com).

6 Electrical connection



The unit must be connected by a qualified electrician.

The national and international regulations for the installation of electrical equipment must be adhered to.

Voltage supply according to EN 50178, SELV, PELV.

- ▶ Disconnect power.
- ▶ Connect the unit as follows:

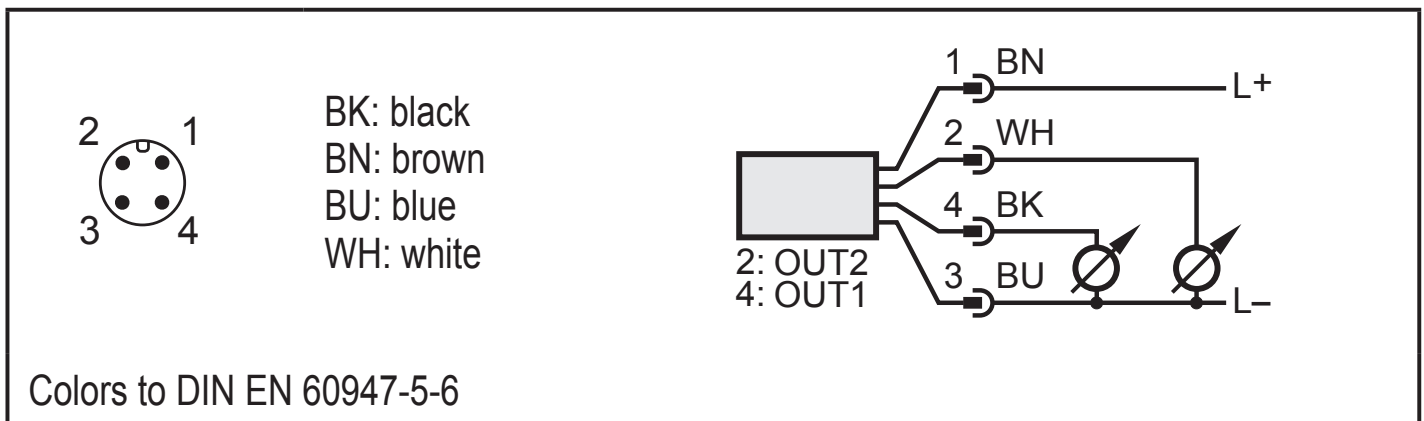

| | |
|-------------------------|---------------------------------|
| Pin 1 | L+ |
| Pin 3 | L- |
| Pin 4 (OUT1) | • Analog signal for temperature |
| Pin 2 (OUT2) | • Analog signal for flow rate |

7 Operating and display elements

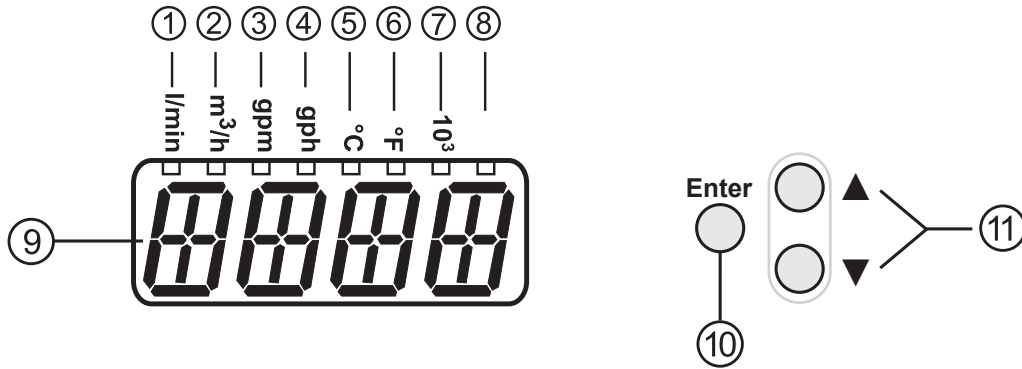

1 to 8: indicator LEDs

- LEDs 1-6 = Unit of the currently represented numerical value → 11.1 Reading the process value
- LED 7 = current process value in 10³
- LED 8 = not used

9: Alphanumeric display, 4 digits

- Current flow rate (with setting [SELd] = [FLOW])
- Current medium temperature (with setting [SELd] = [TEMP])
- Parameters and parameter values

10: [Enter] button

- Selection of the parameters
- Reading of the set values
- Confirmation of the parameter values

Representation in → 8 Menu: ○

11: Buttons up [▲] and down [▼]

- Selection of the parameters
- Activation of the setting functions
- Changing the parameter values
- Change of the display unit in the normal operating mode (Run mode)
- Locking / unlocking

Representation in → 8 Menu: ▲ and ▼

8 Menu

8.1 Process value display

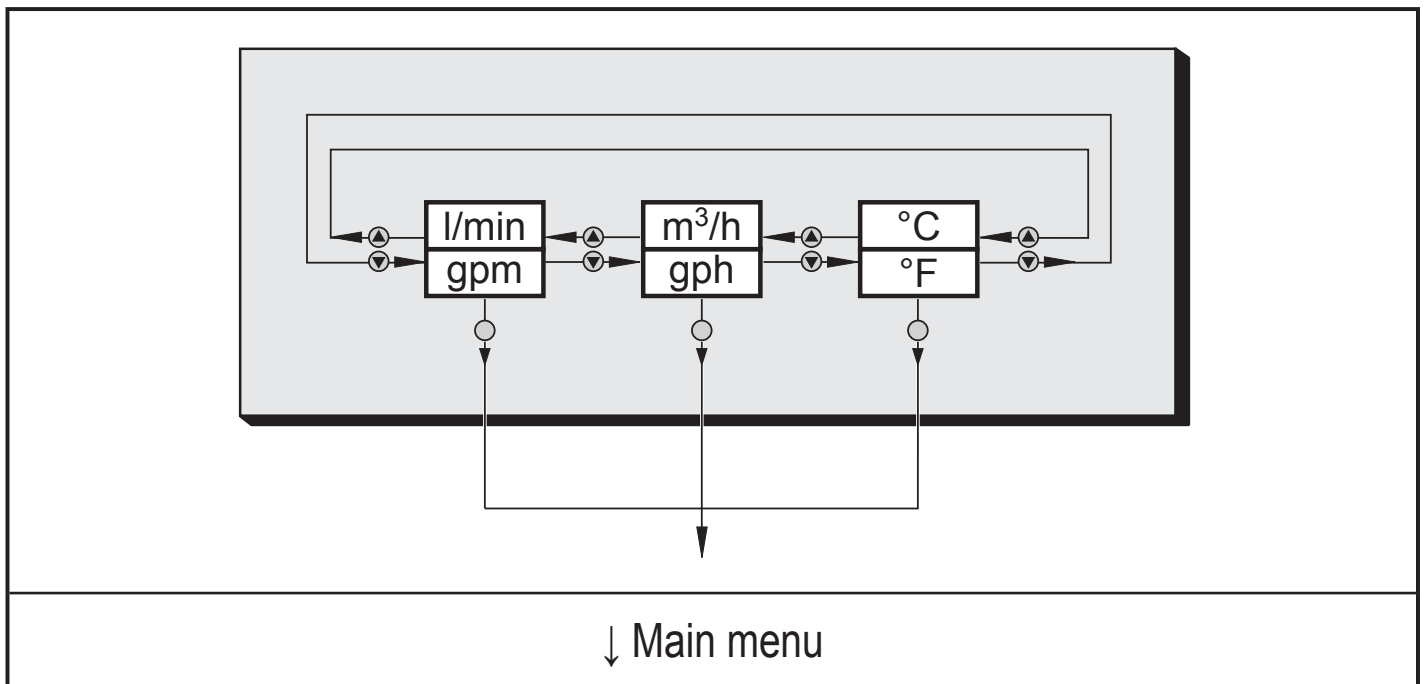

8.2 Main menu, Extended functions

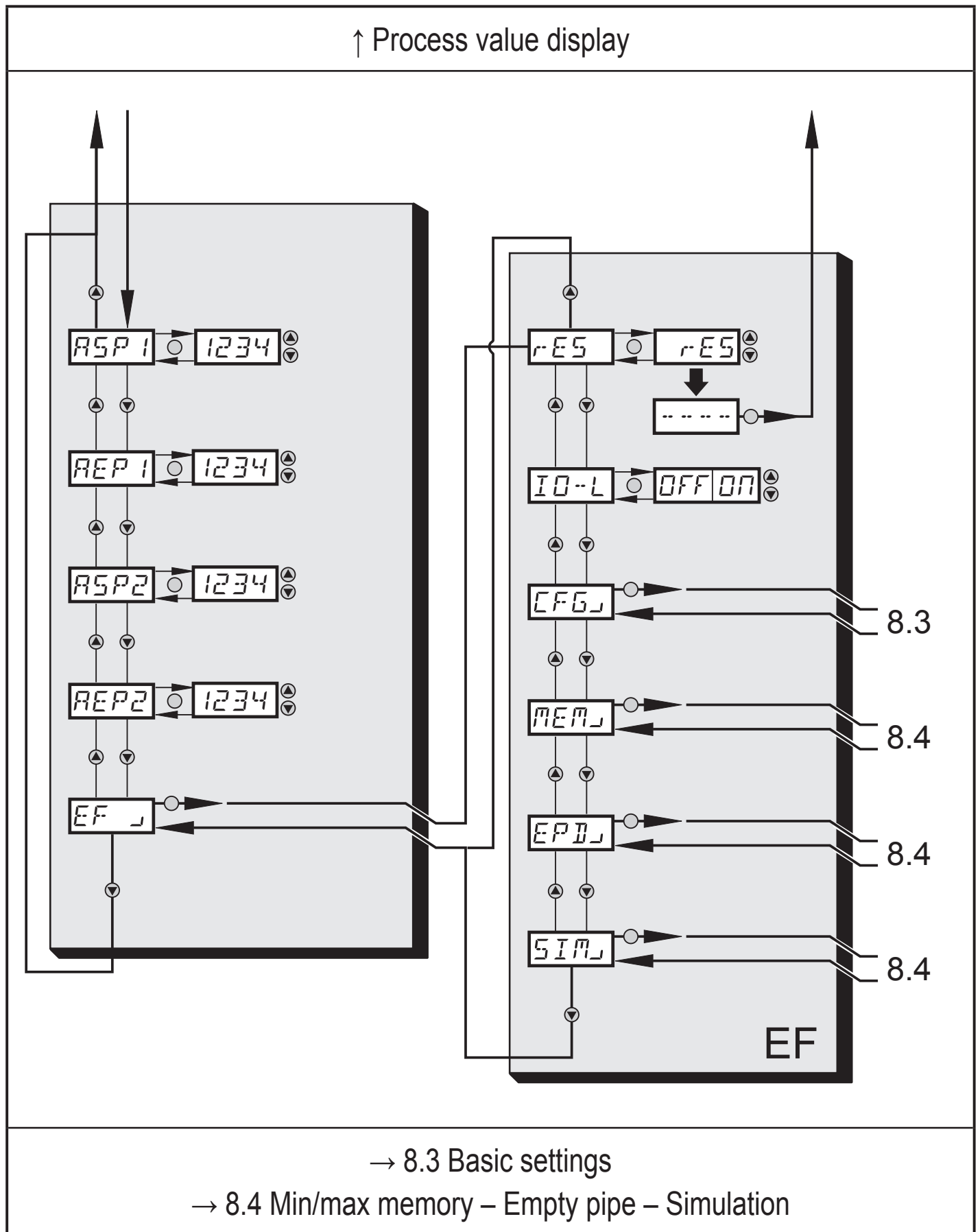

Explanation main menu

| | |
|------|--|
| ASP1 | Analog start value for temperature |
| AEP1 | Analog end value for temperature |
| ASP2 | Analog start value for flow rate |
| AEP2 | Analog end value for flow rate |
| EF | Extended functions / opening of menu level 2 |

Explanation extended functions (EF)

| | |
|------|---|
| rES | Restore factory setting |
| IO-L | Parameter not used. Must be set to [OFF]. |
| CFG | Submenu basic settings |
| MEM | Submenu min/max memory |
| EPD | Submenu empty pipe |
| SIM | Submenu simulation |

8.3 Basic settings

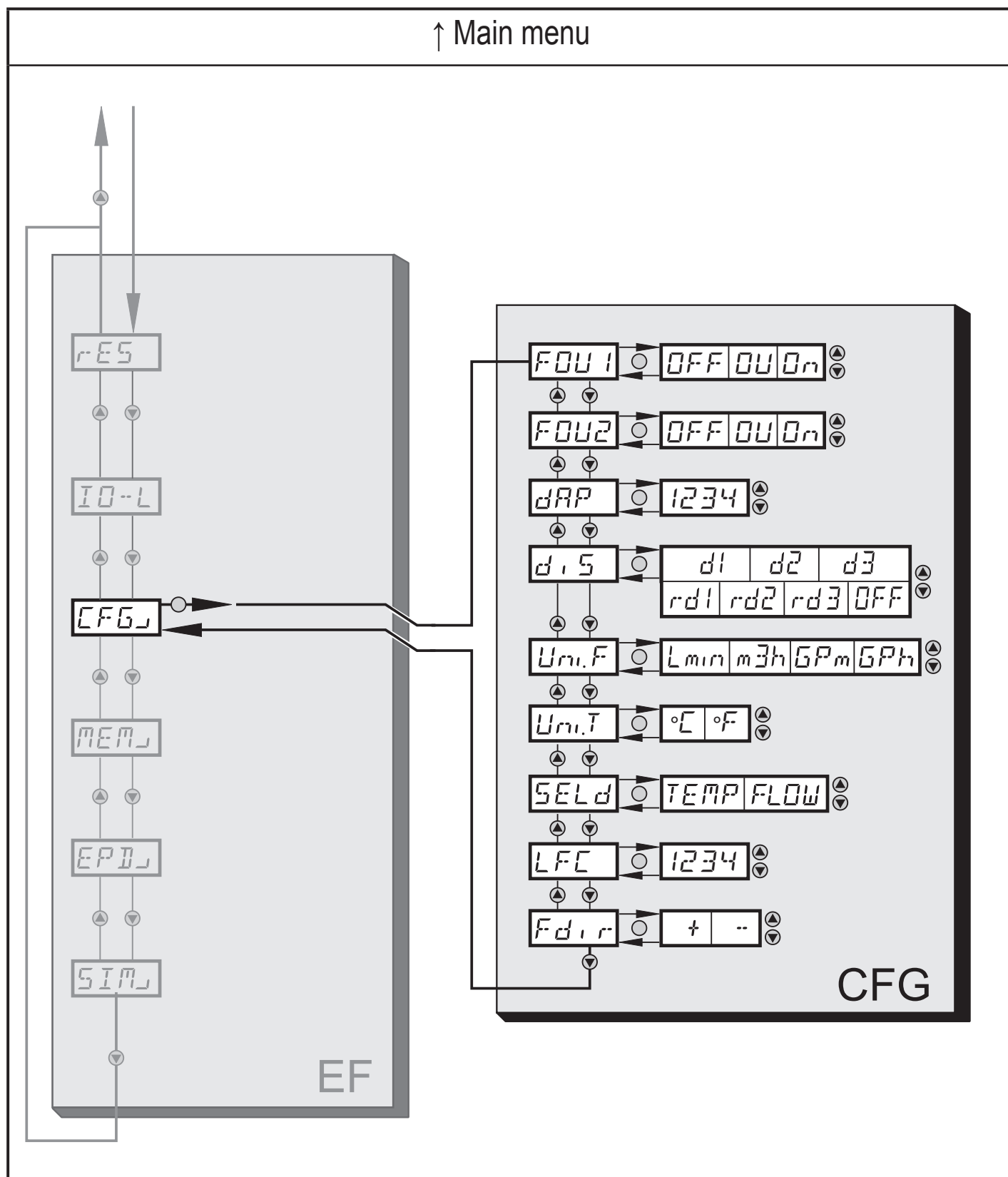

Explanation basic settings (CFG)

| | |
|-------|--|
| FOU1 | Behavior of output 1 in case of an error |
| FOU2 | Behavior of output 2 in case of an error |
| dAP | Measured value damping / damping constant in seconds |
| diS | Update rate and orientation of the display |
| Uni.F | Standard unit of measurement for flow rate |
| Uni.T | Standard unit of measurement for temperature |
| SELd | Standard measuring unit of the display: flow rate value / medium temperature |
| LFC | Low flow cut-off |
| Fdir | Direction of flow |

8.4 Min/max memory – Empty pipe – Simulation

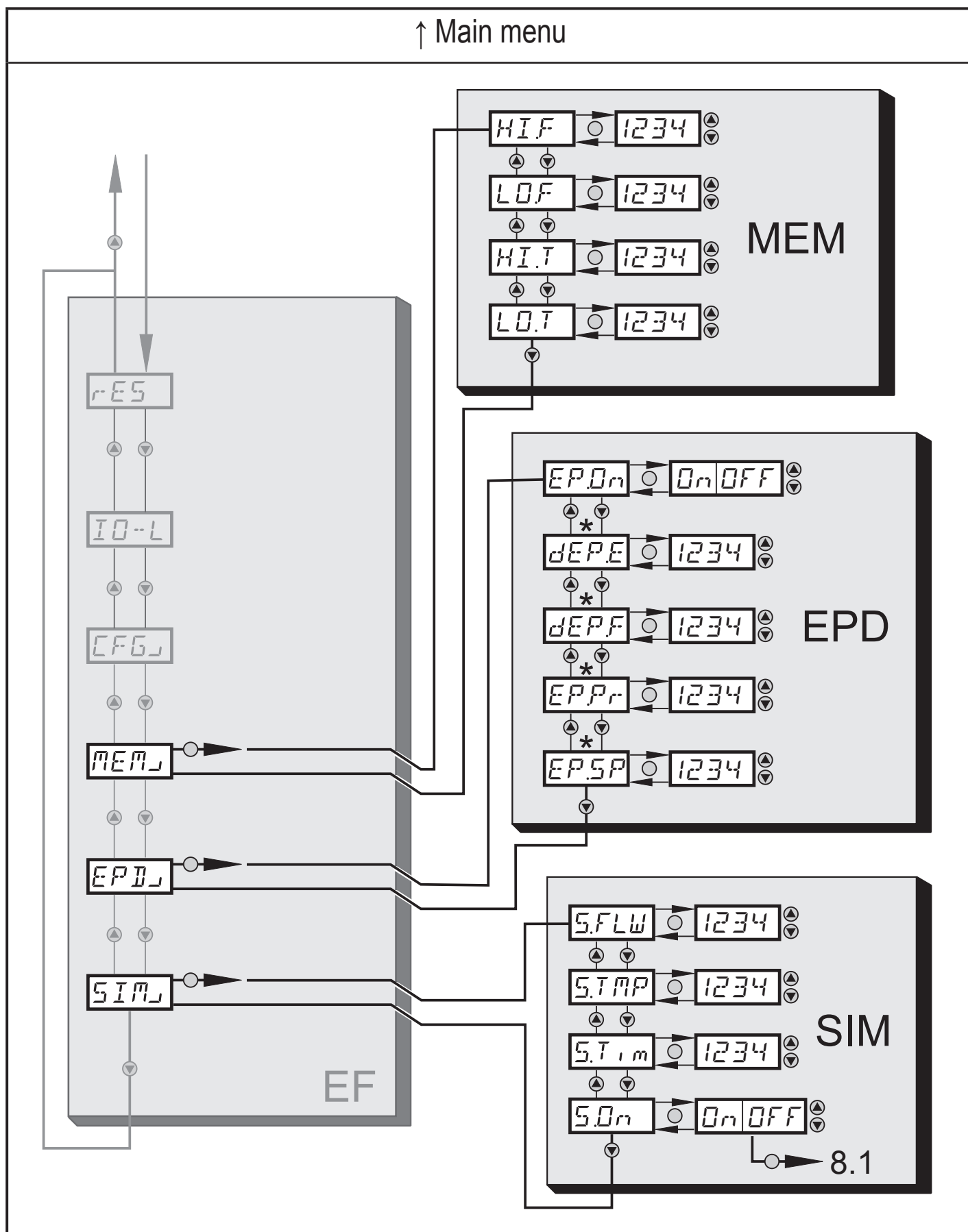

* Parameters are only displayed for the selection EP.On = On.

Explanation min/max memory (MEM)

| | |
|------|------------------------|
| HI.F | Max. value flow |
| LO.F | Min. value flow |
| HI.T | Max. value temperature |
| LO.T | Min. value temperature |

Explanation empty pipe (EPD)

| | |
|--------|--|
| EP.On | Empty pipe detection on / off |
| dEP.E. | Delay time empty signal |
| dEP.F | Delay time full signal |
| EP.Pr | Current measured value of empty pipe detection |
| EP.SP | Switch point of empty pipe detection |

8.5 Explanation simulation (SIM)

| | |
|-------|------------------------------|
| S.FLW | Simulation flow value |
| S.TMP | Simulation temperature value |
| S.Tim | Simulation time |
| S.On | Simulation start |

9 Set-up

After power on and completion of the power-on delay time (approx. 5 seconds) the unit is in the normal operating mode. It carries out its measurement and evaluation functions and generates output signals according to the set parameters.

For the analog output 2 (OUT2), the output signal is 20 mA during the power-on delay time.

In the first 2 seconds, analog output 1 (OUT1) is passive. During the remaining power-on delay time, the output signal is at 20 mA.

10 Parameter setting

Parameters can be set before installation and set-up of the unit or during operation.



If you change parameters during operation, this will influence the function.
▶ Ensure that there will be no malfunctions in your plant.



During parameter setting the unit remains in the operating mode. It continues to monitor with the existing parameter until the parameter setting has been completed.

CAUTION

For medium temperatures above 122 °F some parts of the housing can heat up to over 149 °F.

▶ Do not press the pushbuttons manually; instead use another object (e.g. ballpoint pen).

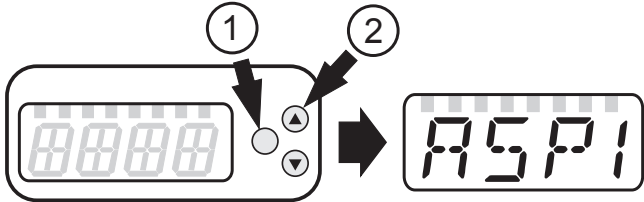
10.1 Parameter setting in general

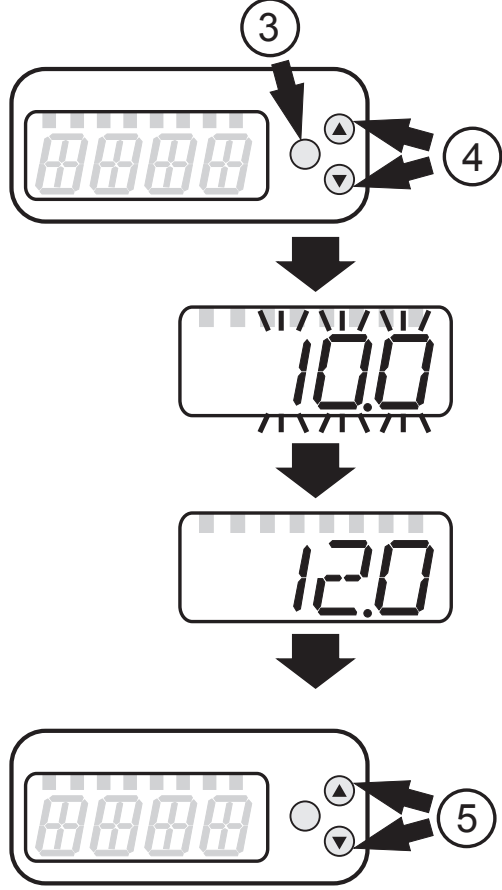
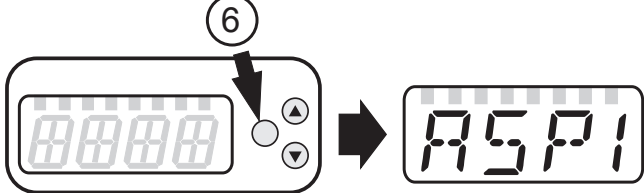
| | |
|---|--|
| <p>Select parameter</p> <ol style="list-style-type: none">1. Press [Enter] briefly.2. Press [▲] or [▼] until the requested parameter is displayed. |  |
| <p>Changing the parameter value</p> <ol style="list-style-type: none">3. Press [Enter] briefly. > The currently set value is displayed.4. Keep [▲] or [▼] pressed for 1 s. > Display flashes first, then permanent.5. Change value by pressing [▲] or [▼]. <p> Keep [▲] or [▼] pressed. > Faster cycle of the numerical values.</p> |  |
| <p>Confirm the parameter value</p> <ol style="list-style-type: none">6. Press [Enter] briefly. > The parameter is displayed again. The new setting value is saved. |  |
| <p>Finish parameter setting and change to the process value display:</p> <ul style="list-style-type: none">▶ Wait for 30 seconds <p>or</p> <ul style="list-style-type: none">▶ Change from the submenu to the main menu, from the main menu to the process value display with [▲] or [▼]. | |

10.1.1 Switching between the menu levels

| | |
|-----------------------------------|---|
| Change to the submenu | Switching to the next submenu via the parameters [EF], [CFG], [MEM], [EPD] or [SIM]. ▶ Select a submenu with [▲] or [▼] and switch to the submenu by pressing [Enter]. |
| Back to the process value display | ▶ Wait for 30 seconds or ▶ Change from the submenu to the main menu, from the main menu to the process value display with [▲] or [▼]. |

10.1.2 Locking / unlocking

The unit can be locked electronically to prevent unintentional settings. On delivery: not locked.

| | |
|-----------|---|
| Locking | <ul style="list-style-type: none"> ▶ Make sure that the unit is in the normal operating mode. ▶ Press [▲] and [▼] simultaneously for 10 s. > [Loc] is displayed. <div style="display: flex; align-items: center; margin-top: 10px;">  <p>During operation: [Loc] is briefly displayed if you try to change parameter values.</p> </div> |
| Unlocking | <ul style="list-style-type: none"> ▶ Press [▲] and [▼] simultaneously for 10 s. > [uLoc] is displayed. |

10.1.3 Timeout

If no button is pressed for 30 s during parameter setting, the unit returns to the operating mode with unchanged parameter.

10.2 Setting the analog value for temperature

| | |
|--|----------------------|
| <ul style="list-style-type: none"> ▶ Select [ASP1] and set the value at which the minimum value is provided. ▶ Select [AEP1] and set the value at which the maximum value is provided. | <pre>ASP1 AEP1</pre> |
|--|----------------------|

10.3 Setting the analog value for flow rate

| | |
|--|----------------------|
| <ul style="list-style-type: none"> ▶ Select [ASP2] and set the value at which the minimum value is provided. ▶ Select [AEP2] and set the value at which the maximum value is provided. | <pre>ASP2 AEP2</pre> |
|--|----------------------|

10.4 User settings (optional)

10.4.1 Setting of the standard unit of measurement for temperature

| | |
|---|-------|
| ▶ Select [Uni.T] and set the unit of measurement: [°C] or [°F]. | Uni.T |
|---|-------|

10.4.2 Setting of the standard unit of measurement for flow rate

| | |
|---|-------|
| ▶ Select [Uni.F] and set the unit of measurement: [Lmin], [m3h], [gpm] or [gph] | Uni.F |
|---|-------|

10.4.3 Configuration of the standard display

| | |
|--|--------------|
| <p>▶ Select [SELd] and determine the standard measuring unit:</p> <ul style="list-style-type: none">- [FLOW] = the current flow rate value in the standard unit of measurement is displayed.- [TEMP] = the current medium temperature is displayed. <p>▶ Select [diS] and set the update rate and orientation of the display:</p> <ul style="list-style-type: none">- [d1] = update of the measured values every 50 ms.- [d2] = update of the measured values every 200 ms.- [d3] = update of the measured values every 600 ms.- [rd1], [rd2], [rd3] = display as for d1, d2, d3; rotated by 180°.- [OFF] = the display is switched off in the operating mode. | SELd d1 S |
|--|--------------|

10.4.4 Changing the direction of the flow rate measurement

| | |
|---|------|
| ▶ Select [Fdir] and set the direction of flow: [+] = flow in the direction of the flow arrow (= factory setting) [-] = flow against the flow arrow ▶ label over the arrow | Fdir |
|---|------|

10.4.5 Setting of measured value damping

| | |
|--|-----|
| ▶ Select [dAP] and set the damping constant in seconds (τ value 63 %). | dAP |
|--|-----|

10.4.6 Setting of the error behaviour of the outputs

| | |
|---|--------------|
| <p>▶ Select [FOU1] and set the value:</p> <ul style="list-style-type: none">- [On] = the analog signal goes to the upper fault value.- [OFF] = the analog signal goes to the lower fault value.- [OU] = the analog signal corresponds to the measured value. <p>▶ Select [FOU2] and set the value:</p> <ul style="list-style-type: none">- [On] = the analog signal goes to the upper fault value.- [OFF] = the analog signal goes to the lower fault value.- [OU] = the analog signal corresponds to the measured value. | FOU1 FOU2 |
|---|--------------|

10.4.7 Activating / deactivating empty pipe detection

| | |
|--|-------|
| <ul style="list-style-type: none">▶ Select [EP.On] and set the function:<ul style="list-style-type: none">- [OFF] = empty pipe detection deactivated.- [On] = empty pipe detection activated. | EP.On |
|--|-------|

10.4.8 Time-delay empty pipe detection

| | |
|--|----------------|
| <ul style="list-style-type: none">▶ Select [dEP.E] and set the delay time from 0...30 s, at which the signal should be provided when the pipe is empty.▶ Select [dEP.F] and set the delay time from 0...30 s, at which the signal should be provided when the pipe is full. | dEP.E dEP.F |
|--|----------------|

10.4.9 Setting of the empty pipe detection

| | |
|--|----------------|
| <ul style="list-style-type: none">▶ Select [EP.Pr] to display the current value of the empty pipe detection in percent.▶ Select [EP.SP] and set the switch point of empty pipe detection. | EP.Pr EP.SP |
|--|----------------|

10.4.10 Setting of the low flow cut-off

| | |
|---|-----|
| <ul style="list-style-type: none">▶ Select [LFC] and set the limit value. | LFC |
|---|-----|

10.5 Service functions

10.5.1 Reading the min/max values for the flow rate

| | |
|--|--------------|
| <ul style="list-style-type: none">▶ Select [HI.F] or [LO.F] [HI.F] = max. value, [LO.F] = min. value. Delete memory: <ul style="list-style-type: none">▶ Select [HI.F] or [LO.F].▶ Press [Enter] briefly.▶ Keep [▲] or [▼] pressed.> [----] is displayed.▶ Press [Enter] briefly. It is recommended to delete the memories as soon as the unit operates under normal operating conditions for the first time. | HI.F LO.F |
|--|--------------|

10.5.2 Reading the min/max values for the temperature

| | |
|---|--|
| <ul style="list-style-type: none">▶ Select [HI.T] or [LO.T] [HI.T] = max. value, [LO.T] = min. value. Delete memory: <ul style="list-style-type: none">▶ Select [HI.T] or [LO.T].▶ Press [Enter] briefly.▶ Keep [▲] or [▼] pressed. > [----] is displayed. <ul style="list-style-type: none">▶ Press [Enter] briefly. It is recommended to delete the memories as soon as the unit operates under normal operating conditions for the first time. |  <p>HI.T LO.T</p> |
|---|--|

10.5.3 Simulation menu

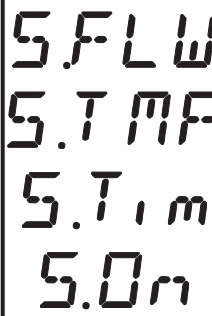
| | |
|---|--|
| <ul style="list-style-type: none">▶ Select [S.FLW] and set the flow value to be simulated.▶ Select [S.TMP] and set the temperature value to be simulated.▶ Select [S.Tim] and set the time of the simulation in minutes.▶ Select [S.On] and set the function:<ul style="list-style-type: none">- [On]: The simulation starts. The values are simulated for the time set at [S.Tim]. [SIM] is displayed simultaneously with the process values. Cancel with [Enter].- [OFF]: The simulation is not active. |  <p>S.FLW S.TMP S.Tim S.On</p> |
|---|--|

10.5.4 Resetting all parameters to factory setting

| | |
|---|---|
| <ul style="list-style-type: none">▶ Select [rES].▶ Press [Enter] briefly.▶ Keep [▲] or [▼] pressed. > [----] is displayed. <ul style="list-style-type: none">▶ Press [Enter] briefly. For the factory settings please refer to the end of these instructions → 13. We recommend recording your own settings in that table before carrying out a reset. |  <p>r-ES</p> |
|---|---|

10.5.5 IO-L Parameter

| | |
|---|---|
|  Parameter not used: <ul style="list-style-type: none">▶ Select [IO-L] and set the function [OFF] |  <p>IO-L</p> |
|---|---|

11 Operation

11.1 Reading the process value

The LEDs 1-6 signal which process value is currently displayed.

The process value to be displayed as standard (temperature, flow rate) can be preset. → 10.4.3 Configuration of the standard display. A standard unit of measurement can be defined for the flow rate (l/min, m³/h, gpm or gph) → 10.4.2). For temperature measurement, °C or °F can be selected as standard unit of measurement (→ 10.4.1).

Further process values can be read in addition to the preset standard display:

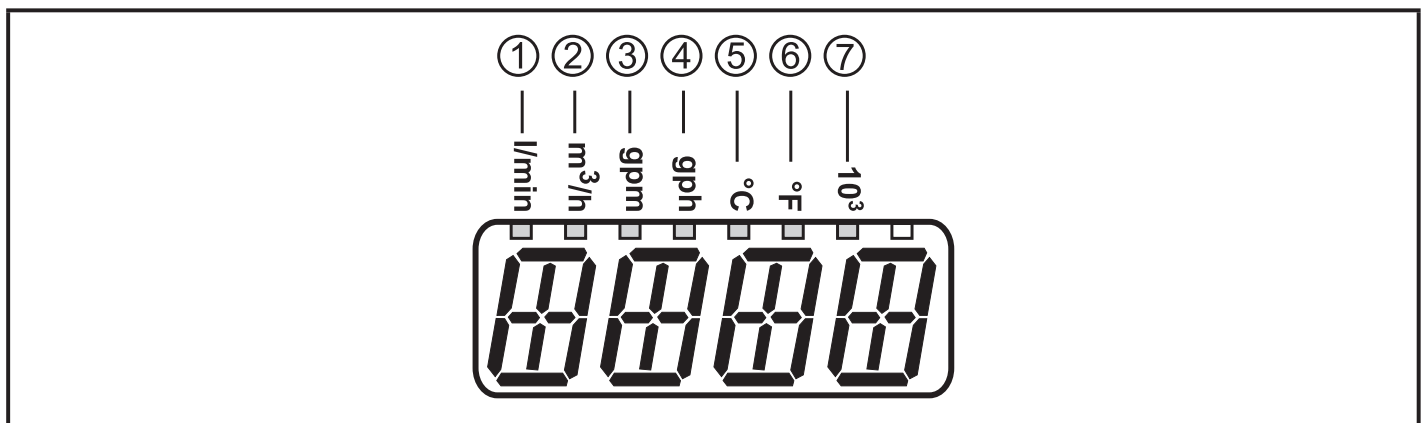

- ▶ Press the buttons [▲] or [▼].
- > The LED of the selected process value display is lit and the current process value is displayed.
- > After 30 seconds the display changes to the standard display.



| LED | Process value display | Unit |
|-----|--|--------------------|
| 1 | Current flow volume per minute | l / min |
| 2 | Current flow volume per hour | m ³ / h |
| 3 | Current flow volume per minute | gal / min |
| 4 | Current flow volume per hour | gal / h |
| 5 | Current medium temperature | °C |
| 6 | Current medium temperature | °F |
| 7 | Current flow volume in 10 ³ | |

11.2 Reading the parameter value

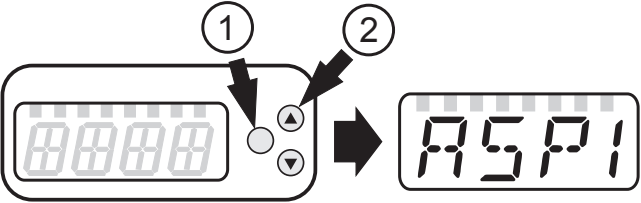
Take the following steps to display the currently set parameter value:

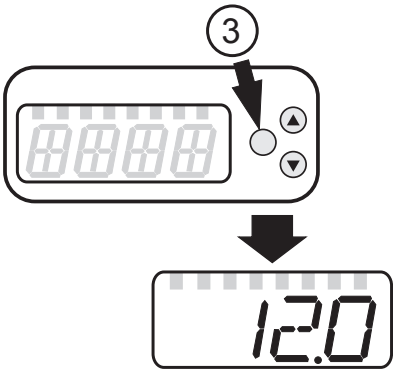
| | |
|--|--|
| <p>Select parameter</p> <ol style="list-style-type: none"> 1. Press [Enter] briefly 2. Press [▲] or [▼] until the requested parameter is displayed. |  |
| <p>Display the parameter value</p> <ol style="list-style-type: none"> 3. Press [Enter] briefly <p>> The currently set value is displayed for 30 s.</p> <p> By pressing [Enter] briefly several times, the display switches between parameter and parameter value.</p> |  |
| <p>Switching to the process value display</p> <ul style="list-style-type: none"> ▶ Wait for 30 seconds <p>or</p> <ul style="list-style-type: none"> ▶ Change from the submenu to the main menu, from the main menu to the process value display with [▲] or [▼]. | |

11.3 Error indications

| | Warning message |
|---------|---|
| [OL] | Detection zone of flow rate or temperature exceeded. Measured value between 120 % and 130 % of the final value of the measuring range. |
| [UL] | Below the detection zone of flow rate or temperature. Measured value between -120 % and -130 % of the final value of the measuring range. |
| [Err] | <ul style="list-style-type: none"> • Unit faulty / malfunction. • Measured value greater than 130 % of the final value of the measuring range. • Measured value lower than -130 % of the final value of the measuring range. |
| [SEnS] | Sensor signal invalid. <ul style="list-style-type: none"> • Measuring pipe not sufficiently filled. • Medium with a too low conductivity. |
| [IOE.n] | Malfunction. The unit is faulty and must be replaced. |

12 Technical data

Technical data and scale drawing at www.automationdirect.com.

13 Factory setting

| | Factory setting | User setting |
|-------------|-----------------|--------------|
| ASP2 (FLOW) | 0 % * | |
| AEP2 (FLOW) | 100 % * | |
| ASP1 (TEMP) | -4 °F | |
| AEP1 (TEMP) | 176 °F | |
| IO-L | OFF | |
| FDir | + | |
| FOU1 | OFF | |
| FOU2 | OFF | |
| dAP | 0.6 s | |
| diS | d2 | |
| Uni.F | gpm | |
| Uni.T | °C | |
| SELd | FLOW | |
| LFC | 1.1 gpm | |
| EP.On | OFF | |
| dEP.E | 0 s | |
| dEP.F | 2 s | |
| EP.SP | 75 % | |
| S.FLW | 20 % * | |
| S.TMP | 68 °F | |
| S.Tim | 3 min | |
| S.On | OFF | |

* of the final value of the measuring range

More information at www.automationdirect.com

