

# Monitor Holder 5-Axis Part# 162900 Assembly Procedure



Copyright 2023, Automationdirect.com Incorporated/  
All Rights Reserved Worldwide

## Hardware Included

4X – Button Head Screw  
M4-0.7 x 14mm

1X Low Profile Socket Head  
Cap Screw M8-1.25 x 25mm

1X Allen Wrench, 4,  
mm

2X Low Profile Socket Head  
Cap Screw M8-1.25 x 16mm

2X Socket Head  
Cap Screw  
M8-1.25 x 16mm

1X Allen Wrench,  
6mm

2X Roll-in T-Nut  
with leaf spring,  
Slot size 10, 45  
Series M8-1.25  
thread

2X Roll-in T-Nut  
with leaf spring,  
Slot size 8, 15/40  
Series M8-1.25  
thread

## Step 1

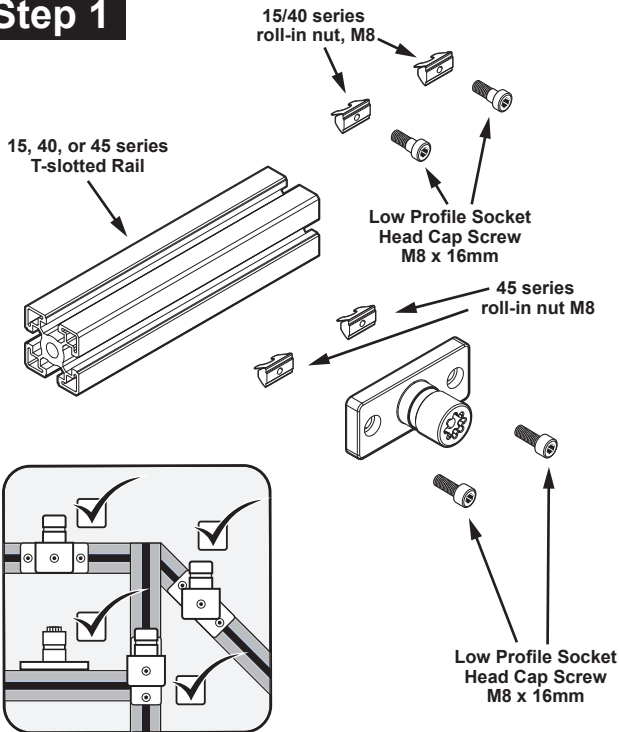

## Step 2

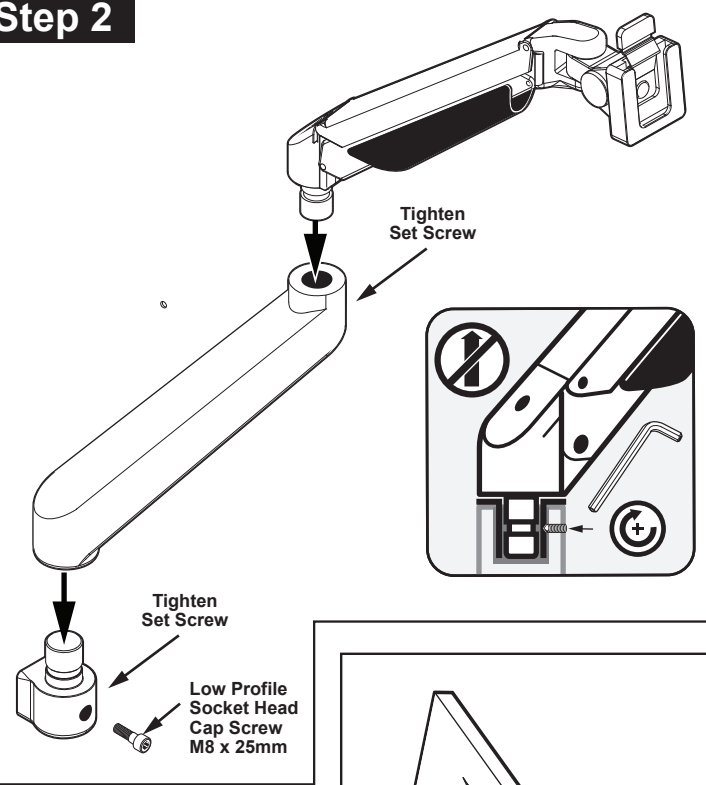

## Adjustments

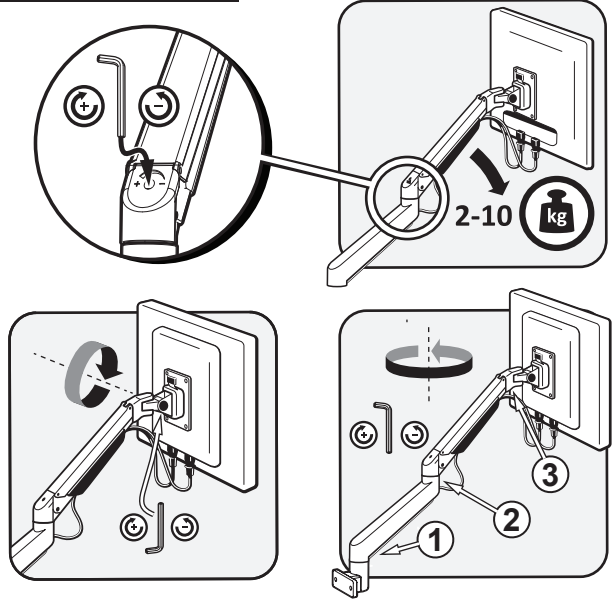

## Step 3

