

Monitor Holder Part# 162896 Assembly Procedure



Copyright 2023, Automationdirect.com Incorporated/
All Rights Reserved Worldwide

Hardware Included

4X – Socket Head
Cap Screw
M4x12

1X – Button Head Socket
Cap Screw
M8-1.25 x 16mm

2X – Button Head Socket
Cap Screw
M8-1.25 x 18mm

1X – Button Head
Socket Cap Screw
M8-1.25 x 30mm

1X – Self-tapping
Screw S7 x 25mm

4X – Washer
M4-0.7

4X – Nut M4-0.7

2X – Nut
M8-1.25

2X – Spring
Washer M8

4X –
Slot Keys

VESA Mounting Standard
☑ 100 X 100mm
☑ 75 X 75mm
☑ 4X M4-0.7 Threaded Holes

1X – Monitor
Mount

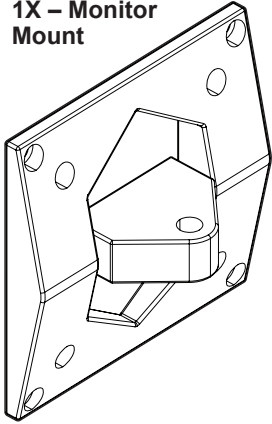

1X – Base Mount

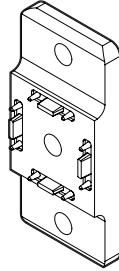

1X – Pivot Piece

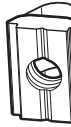
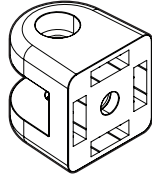

2X – Roll-in T-Nut,
Slot size 8 M8-1.25

Side Mount

Button Head Cap
Screw M8 x 18mm

Button Head Cap
Screw M8 x 30mm

Button Head Cap
Screw M8 x 16mm

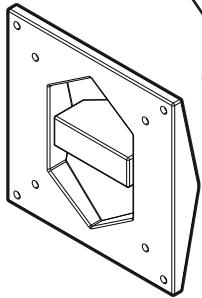

4X M4-0.7 x 12mm
Cap Screw and
4X M4 washer.

4X M4-07 Nut
provided
if needed

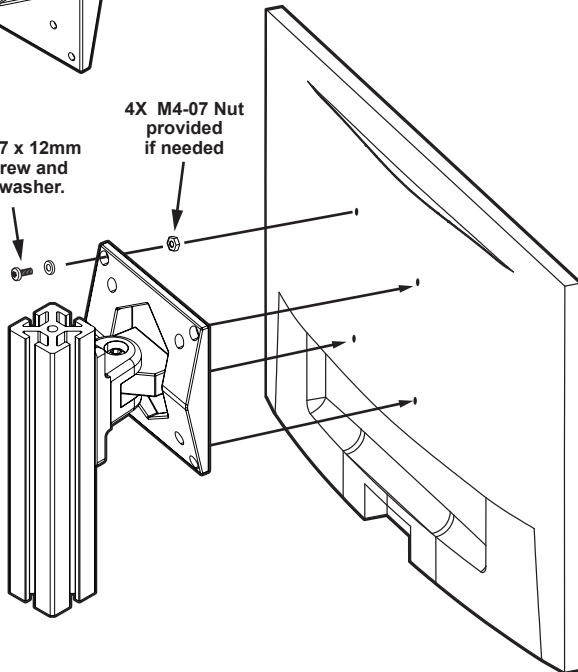

End Mount

Button Head Cap
Screw M8 x 30mm

Self Tapping
Screw
S7 x 25mm

4X M4-0.7 x 12mm
Cap Screw and
4X M4 washer.

4X M4-07 Nut
provided
if needed

