

## Main-features

### ✓ Vectorial control

The sinusoidal phase current with "else" technology keep the motor torque constant allowing smooth and noiseless movements.

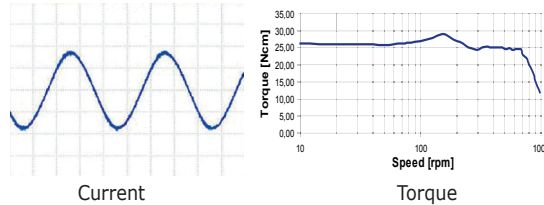

### ✓ Motor stall detection without encoder \*1

### ✓ Smooth movement

### ✓ Compact size

### ✓ Noiseless rotation

### ✓ Reliability

### ✓ Low EM emissions

### ✓ Software resonance damping

### ✓ Auto tuning of motor control parameters

### ✓ High efficiency current set up

### ✓ Reduction of moto temperature

\*1 only for LW3D30xx models

## Specifications

### MODELS

Code	Power supply	Current max	Motors type
LW3D2030	12 ÷ 36 Vdc	3.0 Arms	2 phases
LW3D3032	24 ÷ 80 Vdc	3.2 Arms	2 phases
LW3D3070	24 ÷ 80 Vdc	7.1 Arms	2 phases

### OPTO ISOLATED INPUTS

4 Digital IN NPN, PNP or Line-Driver 2 MHz

### OPTO ISOLATED OUTPUT

1 Digital OUT 24 Vdc - 100 mA for status monitoring

### STEP RESOLUTION

From full step up to 1/256 (emulated)

### SAFETY PROTECTIONS

Over/Under voltage, Over Current, Over Temperature, Short Circuit Phase/Phase and Phase/Ground

### STATUS MONITORING

3 LED with guiding light (green and red/yellow)

### TEMPERATURE

Working: from 0°C to 40°C. Storage: from -25°C to 55°C

### HUMIDITY

5% ÷ 85%

### PROTECTION CLASS

IP20

## Vectorial drivers for 2 phases stepper motors



error  
less  
servo  
efficient  
**else**  
technology  
by Ever Elettronica

**TITANIO**  
VECTOR - STEPPER - DRIVES



# LW3D Titanio drivers

- Equipped with advanced safety features:
  - ✓ Sensorless motor stall detection
  - ✓ Integrated diagnostic
  - ✓ Protections against short circuit motor, open phases, over/under voltage and temperature

LW3D drivers of Titanio series, based on Arm Core M4 technology, are the solution to control stepper motors in clock&direction mode with an accuracy, smoothness and noiseless never seen before for a stepper driver.



EVER MOTION CONTROL  
Via del Commercio, 2/4 -9/11  
Loc. S. Grato - Z.I.  
26900 - LODI (LO) - Italy  
Tel. 0039 0371 412318 - Fax 0039 0371 412367  
email infoever@everelettronica.it  
www.everelettronica.it

## STEP & DIRECTION

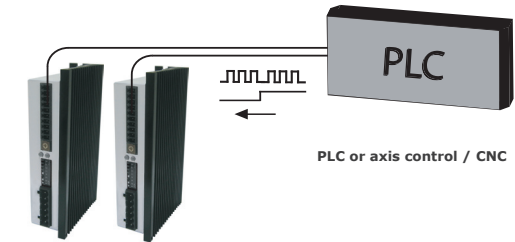

- Setting of the current value by means of dip-switches
- Selection of the step angle by means of roto-switches. In order to maintain compatibility with traditional drivers, step angles have been emulated through software, the current regulation is always sinusoidal.

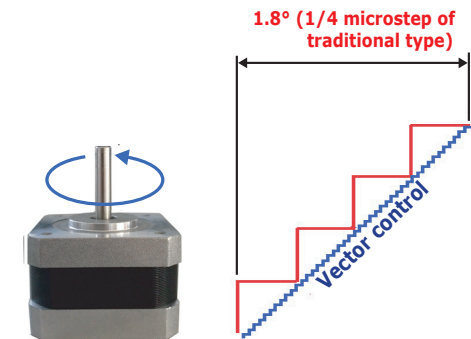

- Possibility to select five user functions:
  - 1 - enabling of motor stall detection. Reading the motor BEMF, LW3 drivers detect without encoder the step loss, showing alarm status with the Fault digital OUT and a LED sequence.
  - 2 - Step/Direction or Clock-Up / Clock-Down control mode.
  - 3 - enable input management (safety control).
  - 4 - 30% or 70% automatic current reduction (still motor).
  - 5 - enabling of "Clock Test" function, useful during the driver's installation, which shows the right presence of the clock signal through status LED flashing.

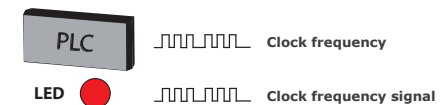

## Inputs Connection

Connection of Step and Direction signals

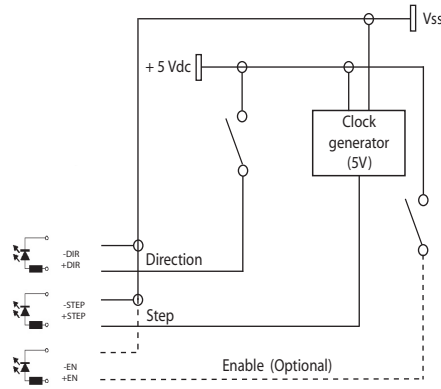

Connection of Clock-Up & Clock-Down signals

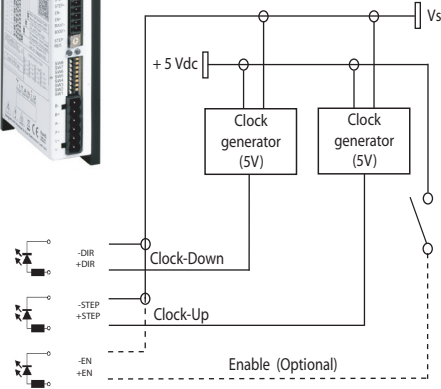

## Mechanical Data

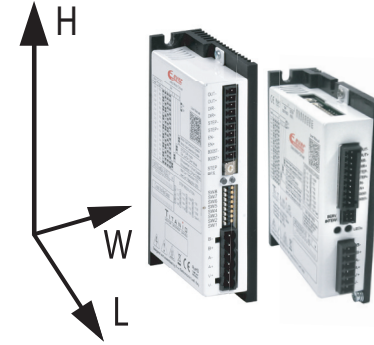

Models	Dimensions (mm)			Weight (g.)
	H	L	W	
LW3D2030N2A1-00	95.0	73.0	23.0	290
LW3D30xxN0A1-00	128.0	74.0	30.0	290

## Ordering Information for LW3D Drives

Ordering code	Power		System resources		
Versions	Power Supply	Current	Digital Inputs	Analog Inputs	Digital Outputs
<b>LW3D Drive Series: Models 2030</b>					
LW3D2030N2A1-00	12 ÷ 36 Vdc	0.10 ÷ 3.0 Arms (0.14 ÷ 4.2 Apeak)	4 opto isolated 5-24 Vdc NPN, PNP or Line Driver 2 MHz	---	1 opto isolated 24 Vdc 100 mA PNP for FAULT
<b>LW3D Drive Series: Models 3032</b>					
LW3D3032N0A1-00	24 ÷ 80 Vdc	0.21 ÷ 3.2 Arms (0.3 ÷ 4.5 Apeak)	4 opto isolated 2-24 Vdc NPN, PNP or Line Driver 2 MHz	---	1 opto isolated 24 Vdc 100 mA PNP for FAULT
<b>LW3D Drive Series: Models 3070</b>					
LW3D3070N0A1-00	24 ÷ 80 Vdc	1.70 ÷ 7.1 Arms (2.4 ÷ 10.0 Apeak)	4 opto isolated 2-24 Vdc NPN, PNP or Line Driver 2 MHz	---	1 opto isolated 24 Vdc 100 mA PNP for FAULT