



# Errata Sheet

This Errata Sheet contains corrections or changes made after the publication of this manual.

---

**Product Family:** DL405 **Date:** December 11, 2018  
**Manual Number:** D4-USER-M  
**Revision and Date:** 4th Edition, Rev. A; March 2013

---

## Changes to Chapter 2. Installation, Wiring, and Specifications

Page 2-4. Safety Guidelines; Class 1, Division 2 Approval

*Delete this section, including the two warnings. The DL405 system is NOT Class 1, Division 2 approved.*

Page 2-44. D4-32TD1-1, 5-15VDC Output

*Add the following NOTE to the specifications table for this module:*

**NOTE:**The D4-32TD1-1 module operates on reverse logic. Voltage is present when Output is Off; no voltage is present when output is On.

## Changes to Chapter 4. System Design and Configuration

Page 4-8. Calculating the Power Budget; Module Power Requirements

*Change the “5V Current Required (mA)” values in the table for these analog modules:*

*F4-04AD: Change from 85 mA to 150 mA*

*F4-04ADS: Change from 270 mA to 370 mA*

Page 4-18. Network Connections to MODBUS and DirectNET; Configuring the CPU's Comm Ports

*Change the NOTE near the bottom of the page to say:*

*NOTE: The recommended cable for RS-232 and RS-422 is AutomationDirect L19772-1 (Belden 8102) or equivalent.*

## Changes to Chapter 5. Standard RLL Instructions; Accumulator Logic Instructions

Page 5-85. Compare with Stack (CMPS)

*The table below has more accurate descriptions for the discrete bit flags than the descriptions in the manual:*

Discrete Bit Flags	Description
SP60	On when the value in the Accumulator is less than the first level value in the Accumulator Stack.
SP61	On when the value in the Accumulator is equal to the first level value in the Accumulator Stack.
SP62	On when the value in the Accumulator is greater than the first level value in the Accumulator Stack.



# Errata Sheet

This Errata Sheet contains corrections or changes made after the publication of this manual.

## Changes to Chapter 8. PID Loop Operation (DL450 only)

Page 8-36. Monitor Limit Alarms. Add the following note at the end of this page:



**NOTE:** PID deviation alarm only works in Auto mode.

## Changes to Chapter 9. Maintenance and Troubleshooting

Page 9-26. Add the following to the end of this chapter (right after BREAK Instruction placement):

### Reset the PLC to Factory Defaults

**NOTE:** Resetting to factory defaults will not clear any password stored in the PLC.

Resetting a DirectLogic PLC to Factory Defaults is a two-step process. Be sure to have a verified backup of your program using “Save Project to Disk” from the File menu before performing this procedure. Please be aware that the program as well as any settings will be erased and not all settings are stored in the project. In particular you will need to write down any settings for Secondary Communications Ports and manually set the ports up after resetting the PLC to factory defaults.

Step 1 – While connected to the PLC with DirectSoft, go to the PLC menu and select; “Clear PLC Memory”. Check the “ALL” box at the bottom of the list and press “OK”.

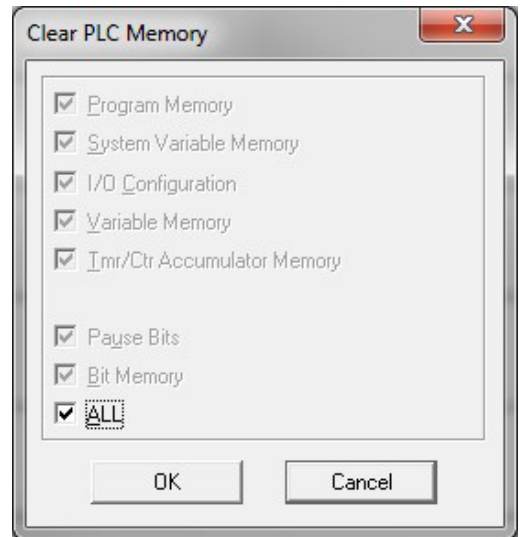

Step 2 – While connected with DirectSoft, go the PLC menu and then to the “Setup” submenu and select “Initialize Scratch Pad”. Press “OK”.

**NOTE:** All configurable communications ports will be reset to factory default state. If you are connected via Port 2 or another configurable port, you may be disconnected when this operation is complete.

**NOTE:** Retentive ranges will be reset to the factory settings.

**NOTE:** Manually addressed IO will be reset to factory default settings.

The PLC has now been reset to factory defaults and you can proceed to program the PLC.





# Errata Sheet

**This Errata Sheet contains corrections or changes made after the publication of this manual.**

## **Changes to Appendix I. European Union Directives (CE)**

Page I-4. Special Installation Manual

*Delete this section. Manual D-EU-M is no longer available. Instead, refer to the websites listed below:*

Page I-4: Other Sources of Information

*Replace the text that follows the sentence "It may be possible to obtain this information locally; however, the official source of applicable Directives and related standards is:" with the following updated information:*

Publications Office

2, rue Mercier

2985 Luxembourg

LUXEMBOURG

Quickest contact is via the web at:

<http://ec.europa.eu/growth/single-market/european-standards/harmonised-standards>

Another source is the British Standards Institution at:

British Standards Institution – Sales Department, Linford Wood:

Milton Keynes, MK14 6LE, United Kingdom.

The quickest contact is via the web at <http://www.bsigroup.com>

Another source is

The 'Blue Guide' on the implementation of EU product rules 2016

[https://ec.europa.eu/commission/index\\_en](https://ec.europa.eu/commission/index_en)

Page I-10. Items Specific to the DL405

*Ignore the reference to manual D-EU-M in the first paragraph of this section. That manual is no longer available. See the websites listed above.*

# Maintenance and Troubleshooting

---

In This Chapter. . . .

- Hardware Maintenance
  - Diagnostics
  - CPU Indicators
  - I/O Module Troubleshooting
  - Noise Troubleshooting
  - Machine Startup and Program Troubleshooting
-

## Hardware Maintenance

### Standard Maintenance

A routine maintenance check (about every one or two months) on your PLC and control system is good practice, and should include the following items:

- **Air Temperature** – Check the ambient air temperature in the control cabinet, so the operating temperature range of any component is not exceeded.
- **Air Filter** – If the control cabinet has an air filter, clean or replace it periodically as required.
- **Memory Backup Battery** – Make sure the CPU memory backup battery does not become completely discharged. The CPU uses the same battery indicator to signal a low CPU battery and if applicable a low memory cartridge battery. Make sure you have correctly diagnosed which battery is requiring replacement.
- **Fuses or breakers** – verify that all fuses and breakers are intact.
- **DL405 Module Air Vents** – verify that all air vents of the CPU and all I/O modules are clear, allowing air to circulate for cooling.

### CPU Battery Replacement

The CPU battery is used to retain program V-memory and the system parameters. The life expectancy of this battery is five years.



**NOTE:** Before replacing your CPU battery you should back-up your V-memory and system parameters. This can be done by saving the V-memory and system parameters to either a Memory Cartridge or to cassette tape or by using *DirectSOFT* to save the program to hard/floppy disk on a personal computer.

To prevent memory loss the CPU battery can be changed while the system is powered up. If the CPU has been powered off you should power-up the CPU for at least 5 seconds prior to changing the battery. This is done to ensure the capacitor used to maintain the proper voltage levels necessary to retain memory is fully charged.

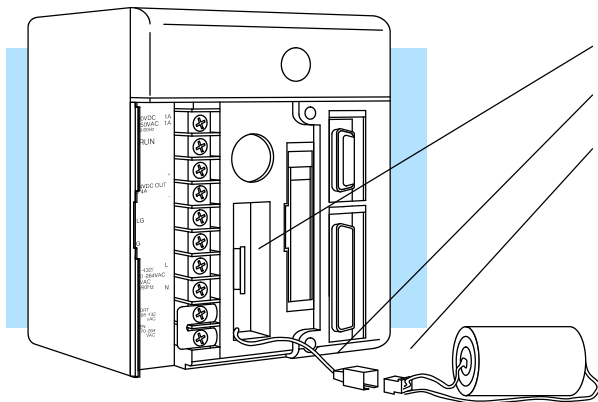

Replace battery with  
part #D3-D4-BAT

To replace the CPU battery:

- Pull the battery out from the battery retaining clip.
- Lift the clip on the two wire battery connector.
- Slide the battery connector apart.

To install the CPU battery:

- Join the (keyed) battery connector so the red wires match.
- Push gently till the connector snaps closed
- Slide the battery into the battery retaining clip till the battery lies flush in the opening.
- Note the date the battery was changed.

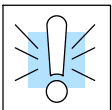

**WARNING:** Do not attempt to recharge the battery or dispose of it by fire. The battery may explode or release hazardous materials.

## CMOS RAM Memory Cartridge Battery Replacement



The CMOS RAM Memory Cartridge battery is used to maintain the contents of the Memory Cartridge RAM when the power is turned off. The life expectancy of this battery is three years.

**NOTE:** For added security you will want to save the contents of the memory cartridge to either another memory cartridge, cassette tape, or computer disk, to avoid losing the contents of the memory cartridge when the battery is removed. The memory cartridge does however have a built in capacitor to retain the memory for several minutes while the battery is being replaced. If the system has been powered off, you should power-up the CPU with the memory cartridge installed for at least 5 seconds prior to changing the battery. This is done to ensure the capacitor used to maintain the proper voltage levels necessary to retain memory is fully charged.

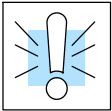

**WARNING:** Never remove the Memory Cartridge from the CPU when the CPU is powered-up. If the memory cartridge is removed while under power the memory cartridge may become unreliable. Do not attempt to recharge the battery or dispose of it by fire. The battery may explode or release hazardous materials.

To remove the CMOS RAM Memory Cartridge battery:

1. Power down the CPU.
2. Remove the memory cartridge from the CPU by gently pulling the lever down till the cartridge is loosened, then pull the lever straight out .
3. Remove the cover retaining screw.
4. Lift top cover off (lifting at a slight tilt to avoid breaking the guides beside the connector).
5. Grasp battery and lift straight up.

To install the CMOS RAM Memory Cartridge battery:

1. Align the battery leads to the (keyed) holes in the circuit board.
2. Press the battery flush with the circuit board.
3. Place cover back on module (using a slight tilt to catch the guides beside the connector).
4. Install the cover retaining screw.
5. Note the date the battery was changed.

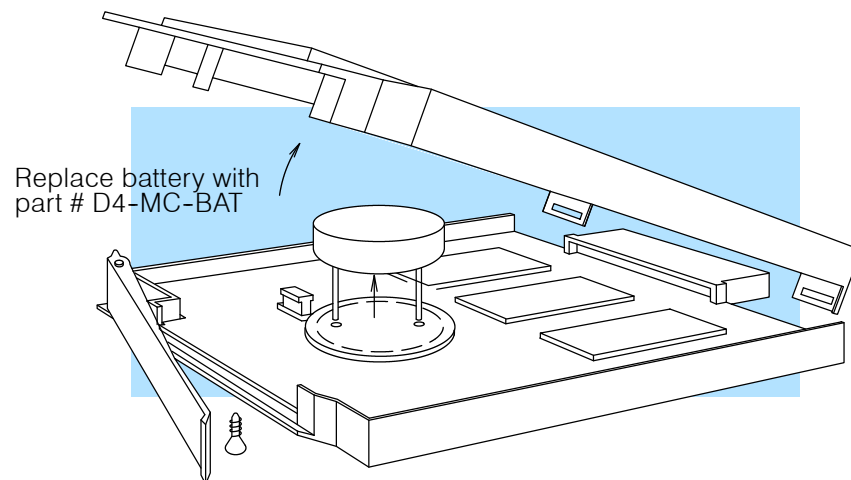

## Diagnostics

### Diagnostics

DL405 performs over 90 pre-defined diagnostic routines with every CPU scan. The diagnostics have been designed to detect failures for the CPU local base and local expansion bases. These detected errors cover the following: CPUs, expansion units, I/O, bases, communication modules, memory cartridges and batteries. There are two primary error classes: fatal and non-fatal.

### Fatal Errors

Fatal errors are errors the CPU has detected that offer a risk of the system not functioning safely or properly. They will either cause the CPU to change from RUN mode to PROGRAM or will disallow changing from PROGRAM mode to RUN mode. If the fatal error is detected while in PROGRAM mode the CPU will not enter the RUN mode until the error has been corrected.

Examples of fatal errors:

- Power supply failure on the CPU base
- Parity error or CPU malfunction
- Certain programming errors

### Non-fatal Errors

Non-fatal errors are errors that are flagged by the CPU as requiring attention. They can neither cause the CPU to change from RUN mode to PROGRAM nor do they prevent entering RUN mode. There are special relays the application program can use to detect if a non-fatal error has occurred. The application program can then be used to take the system to an orderly shutdown or switch the PLC out of RUN mode if needed.

Example of non-fatal errors are:

- Battery backup battery voltage low
- All I/O module errors
- Certain programming errors

### Finding Diagnostic Information

Diagnostic information can be found in several places with varying levels of message detail.

- The CPU automatically logs error codes and any FAULT messages into two separate tables which can be viewed with the Handheld or **DirectSOFT**.
- The handheld programmer displays error numbers and short descriptions of the error.
- **DirectSOFT** provides the error number and an error message.
- Appendix B in this manual has a complete list of error messages sorted by error number.

Many of these messages point to supplemental memory locations which can be referenced for additional related information. These memory references are in the form of V-memory and SPs (special relays).

The following two tables name the specific memory locations that correspond to certain types of error messages. The special relay table also includes status indicators which can be used in programming. For a more detailed description of each of these special relays refer to Appendix D.

**V-memory Error Code Locations**

The following table names the specific memory locations that correspond to certain types of error messages.

Error Class	Error Category	Diagnostic V-memory
Minor	Battery Voltage (DL450)	V7746
System	10ms calendar timer (DL440/450)	V7747
User-defined	Fault message error code	V7751
I/O configuration	Current module ID code	V7752
I/O configuration	Correct module ID code	V7753
I/O configuration	Base number/Slot number	V7754
Fatal	Error code	V7755
Major	Error code	V7756
Minor	Communications Error code	V7757
Module	Base number/Slot number	V7760
Module	Error code	V7762
Grammatical	Address	V7763
Grammatical	Error Code	V7764

**Special Relays (SP) Corresponding to Error Codes**

The special relay table also includes status indicators which can indicate errors. For a more detailed description of each of these special relays refer to Appendix D.

Startup and Real-time Relays		CPU Status Relays		System Monitoring Relays		Accumulator Status Relays		Communication Monitoring Relays	
SP0	First scan relay	SP11	Forced run mode relay	SP40	Critical error relay	SP60	Value less than relay	SP120	Module busy relay Slot 0
SP1	Always ON relay	SP12	Terminal run mode relay	SP41	Warning relay	SP61	Value equal to relay	SP121	Communication error relay Slot 0
SP3	1 minute relay	SP13	Test run mode relay	SP43	Battery low relay	SP62	Value greater than relay	SP122	Module busy relay Slot 1
SP4	1 second relay	SP14	Break relay 1	SP44	Program memory error relay	SP63	Zero relay	SP123	Communication error relay Slot 1
SP5	100 millisecond relay	SP15	Test program mode relay	SP45	I/O error relay	SP64	Half borrow relay	SP124	Module busy relay Slot 2
SP6	50 millisecond relay	SP16	Terminal program mode relay	SP46	Communications error relay	SP65	Borrow relay	SP125	Communication error relay Slot 2
SP7	Alternate scan relay	SP17	Forced stop mode relay	SP47	I/O configuration error relay	SP66	Half carry relay	SP126	Module busy relay Slot 3
		SP21	Break relay 2	SP50	FAULT instruction relay	SP67	Carry relay	SP127	Communication error relay Slot 3
		SP22	Interrupt enabled relay	SP51	Math timeout relay	SP70	Sign relay	SP130	Module busy relay Slot 4
		SP25	CPU battery disabled relay	SP52	Grammatical error relay	SP71	Pointer reference error	SP131	Communication error relay Slot 4
		SP26	I/O update disable relay (DL440)	SP53	Math/Table pointer error	SP73	Overflow relay	SP132	Module busy relay Slot 5
		SP27	Selective I/O update disable relay (DL440)	SP54	Communication error	SP75	Data error relay	SP133	Communication error relay Slot 5
		SP30	Dipswitch 1 status relay	SP56	Table instruction overrun relay	SP76	Load zero relay	SP134	Module busy relay Slot 6
		SP31	Dipswitch 2 status relay					SP135	Communication error relay Slot 6
		SP32	Dipswitch 3 status relay					SP136	Module busy relay Slot 7
		SP33	Dipswitch 4 status relay					SP137	Communication error relay Slot 7



**I/O Module Codes** Each system component has a code identifier. This code identifier is used in some of the error messages related to the I/O modules. The following table list these codes.

Code (Hex)	Component Type	Code (Hex)	Component Type
01	CPU	21	8 pt. Input
02	Expansion Unit	28	16 pt. Output, FL series Analog Output
03	I/O Base	2B	16 pt. Input, FL series Analog Input, Interrupt
11	DCM, All CoProcessor Modules	30	32 pt. Output, DL series Analog Output
12	Remote Master, Slice Master	3F	32 pt. Input, DL series Analog Input
18	High Speed Counter, Magnetic Pulse Input	7F	Abnormal
20	8 pt. Output	FF	No module detected

The following diagram shows an example of how the I/O module codes are used:

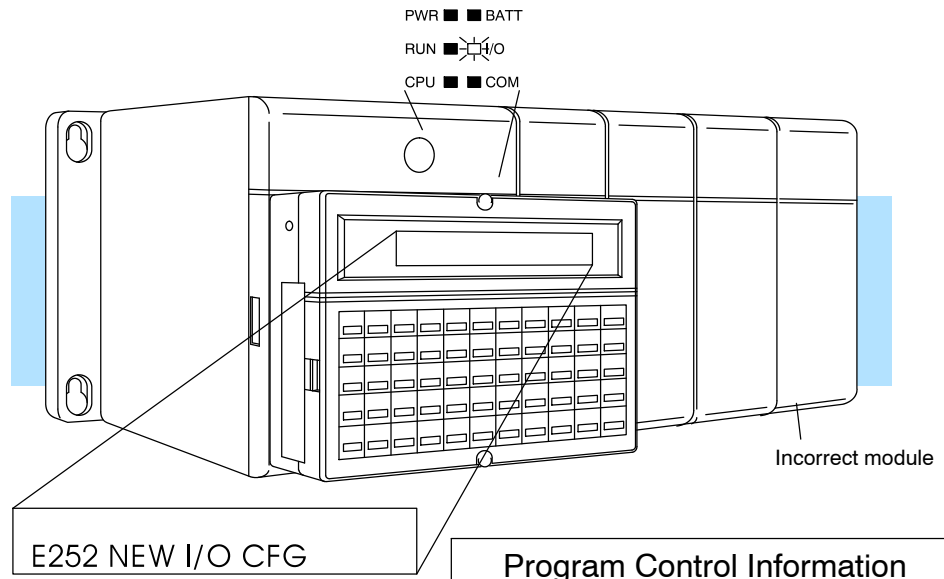

Program Control Information			
V7752	0028	Current module ID code	
V7753	0026	Current module ID code	
V7754	0002	Location of conflict	
V7756	0252	Module Error Code	
SP45	— —	I/O abnormality	

**Error Message Tables**

X	✓	✓
430	440	450

The DL440 and DL450 CPUs will automatically log any system error codes and any custom messages you have created in your application program with the Fault instructions. (See Chapter 11 for details on the Fault instruction.) The CPU logs the error code, the date, and the time the error occurred. There are two separate tables that store this information.

- **System Error Table** - stores up to 32 errors in the table.
- **Fault Message Table** - stores up to 16 messages in the table.

When an error or message is triggered, it is put into the first available table location. *Therefore, the most recent error message may not appear in the first row of the table.* If the table is full when an error occurs, the oldest error is pushed (erased) from the table and the new error is inserted in the row.

The following diagram shows an example of a the Fault Message table as shown in **DirectSOFT**. You can access the error code table and the message table through **DirectSOFT**'s PLC Diagnostic sub-menus. Details on how to access these logs are provided in the **DirectSOFT** manual.

Error Msg. Example

Most recent message appears here, not at the top of the table.

Next message will show up in this row, which is now the oldest message.

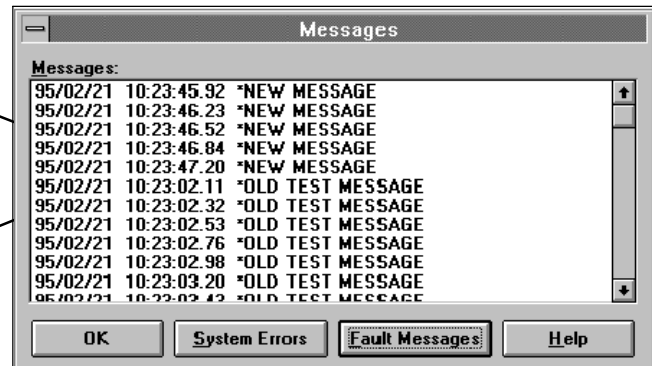

You cannot view the entire table at one time with the handheld programmer. Instead, the messages automatically appear on the handheld programmer display as they occur. The message will remain on the display as long as the Fault instruction is being executed. The following examples show you how to use the Handheld and AUX Function 5C to show the error codes. The most recent error or message is always displayed. You can use the PREV and NXT keys to scroll through the messages.

Use AUX 5C to view the tables

CLR    AUX    5    SHFT    C    ENT  
              

AUX 5C SHOW ERR/MSG  
ERR OR MSG

Arrow key selects Errors or Messages

SHFT    ENT  
     

AUX 5C SHOW ERR/MSG  
ERR OR MSG

Example of a message display

PUMP 3 FAILED  
04/22/93 17:30:00

**System Error Codes**

X	✓	✓
---	---	---

430 440 450

The System error log contains 32 of the most recent errors that have been detected. The errors that are trapped in the error log are a subset of all the error messages which the DL405 systems generate.

The following errors are captured in the System error log upon first detection or reoccurrence.

Error Code	Description	Error Code	Description
E003	Software time-out	E155	RAM failure
E004	Invalid instruction (RAM parity error in the CPU)	E201	Terminal block missing
E041	CPU battery low	E202	Missing I/O module
E043	Memory cartridge battery low	E203	Blown fuse
E099	Program memory exceeded	E206	User 24V power supply failure
E101	CPU memory cartridge missing	E250	Communication failure in the I/O chain
E104	Write fail	E251	I/O parity error
E151	Invalid Command	E252	New I/O configuration

These errors are captured in the System error log if they exist when the CPU attempts to transition to RUN mode.

Error Code	Description	Error Code	Description
E401	Missing END statement	E431	Invalid ISG/SG address
E402	Missing LBL	E432	Invalid jump (GOTO) address
E403	Missing RET	E433	Invalid SBR address
E404	Missing FOR	E434	Invalid RTC address
E405	Missing NEXT	E435	Invalid RT address
E406	Missing IRT	E436	Invalid INT address
E412	SBR/LBL > 64	E437	Invalid IRTC address
E413	FOR/NEXT > 64	E438	Invalid IRT address
E421	Duplicate stage reference	E440	Invalid Data Address
E422	Duplicate SBR/LBL reference	E441	ACON/NCON
E423	Nested loops		

## CPU Status Indicators

The DL405 CPUs have indicators on the front to help you diagnose problems with the system. The table below gives a quick reference of potential problems associated with each status indicator. Following the table is a detailed description of each indicator.

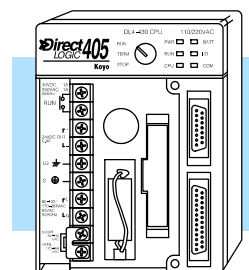

Indicator	Status	Potential Causes
<b>PWR</b>	OFF	<ol style="list-style-type: none"> <li>1. Power input voltage is incorrect for selected operating mode, 110/220 VAC select jumper incorrect on CPU terminal strip</li> <li>2. External power is off or disconnected (check fuses, breakers)</li> <li>3. Power supply/CPU is faulty</li> <li>4. Other component such as an I/O module has power supply shorted</li> <li>5. Power budget exceeded for the CPU being used</li> </ol>
<b>RUN</b>	OFF	<ol style="list-style-type: none"> <li>1. CPU programming error</li> <li>2. Key switch in STOP position</li> </ol>
	Flashing	CPU is in firmware upgrade mode
<b>CPU</b>	ON	<ol style="list-style-type: none"> <li>1. Electrical noise interference</li> <li>2. CPU defective</li> </ol>
<b>BATT</b>	ON, or flashing	<ol style="list-style-type: none"> <li>1. Flashing at 2 Hz: CPU battery low</li> <li>2. Flashing at 0.5 Hz: Memory cartridge battery low (DL440/DL450 only)</li> <li>3. On constantly: Both the CPU and MC batteries are low</li> <li>4. CPU or Memory cartridge battery missing, or disconnected</li> </ol>
<b>DIAG</b> (DL450)	ON	<ol style="list-style-type: none"> <li>1. The CPU internal diagnostics has failed</li> <li>2. The local bus on the backplane has had a communications error</li> </ol>
<b>I/O</b>	ON	<ol style="list-style-type: none"> <li>1. I/O module failure</li> <li>2. External power supply failure</li> <li>3. Configuration error</li> <li>4. Base expansion unit failure</li> </ol>
<b>COM</b> (DL430/ DL440)	ON	<ol style="list-style-type: none"> <li>1. Device port setup incorrect</li> <li>2. Cabling error</li> <li>3. Grounding problem</li> <li>4. Electrical noise</li> <li>5. Device port faulty</li> </ol>
<b>TXD</b> (DL450)	OFF	<ol style="list-style-type: none"> <li>1. The CPU is not transmitting data on the secondary ports (ports 1, 2, and 3), due to programming error</li> <li>2. The CPU is not in Run mode</li> </ol>
<b>RXD</b> (DL450)	OFF	<ol style="list-style-type: none"> <li>1. External device is not transmitting to CPU secondary ports (ports 1, 2, and 3)</li> <li>2. Communications cable is defective, or not connected</li> </ol>

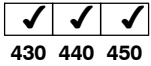
**PWR Indicator**

430 440 450

In general there are four reasons for the CPU or expansion unit power status LED (PWR) to be OFF:

1. Power to the CPU is an improper voltage, or the power range jumper (110/220 select) does not match the power input voltage.
2. CPU power supply is faulty.
3. Other component(s) have the power supply shut down. An I/O module in the base which has shorted is a possibility.
4. Power budget (+5V) for the CPU has been exceeded.

If the voltage to the power supply is not correct, the PLC may not operate properly or may not operate at all. Use the following guidelines to correct the problem.

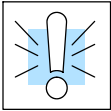

---

**WARNING: To minimize the risk of electrical shock, always disconnect the system power before inspecting the physical wiring.**

---

1. First, disconnect the external power.
2. Verify that all external circuit breakers or fuses are still intact.
3. Check all incoming wiring for loose connections. If you're using a separate termination block, check those connections for accuracy and integrity.
4. If the connections are acceptable, reconnect the system power and verify the voltage at the CPU power input is within specification. If the voltage is not correct, shut down the system and correct the problem.
5. If all wiring is connected correctly and the incoming power is within the specifications, the PLC internal supply may be faulty.

If the voltage to the power supply is not correct, the CPU may not operate properly, if at all. For a new installation on AC-powered CPU versions, first check the 110/220 VAC select jumper on the terminal strip of the CPU. If the 110 VAC selection shunt is not installed while using 110 VAC, you will see the following symptoms:

- The communication ports will not function
- The CPU will only operate when no modules are installed.

If the 110 VAC selection shunt is installed while using 220 VAC, the power supply in the CPU will be damaged. If this has happened, you will need to replace the CPU. The best way to check for a faulty CPU power supply is to substitute a known good one to see if this corrects the problem.

If the jumper is correctly installed for the AC or DC version you are using, then measure the voltage at the terminal strip to ensure it is within the CPU input specs.

It is possible a faulty module or external device using the system 5V can shut down the power supply. This 5V can be coming from the base or from the top port on the CPU. To test for a device causing this problem:

- Turn off power to the CPU.
- Disconnect all external devices (example communication cables) from the CPU.
- Reapply power to the system.

If the power supply operates normally, you probably have either a shorted device or a shorted cable. If the power supply does not operate normally, then test for a module causing the problem by following the steps below:

- Turn off power to the CPU.
- Remove the CPU from the base, leaving its power cord attached.
- Reapply power to the CPU.

If the PWR LED operates normally, the problem is most likely in one of the modules in the local CPU base. To isolate which module is causing the problem, remove one module at a time until the PWR LED operates normally. Put the CPU back in the base prior to testing for a bad module. Follow the procedure below:

- Turn off power to the CPU.
- Remove a module from the base.
- Reapply power to the CPU.

Bent base connector pins on the module can cause this problem, so check the connector. Remember that exceeding the power budget is a common error that will cause the PWR indicator to not come on or to come on intermittently.

Power budgeting problems usually appear during system start-up, rather than after a long period of operation. If there is any doubt, it's a good idea to recheck this.

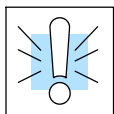

**WARNING: The PLC may reset if the power budget is exceeded. If there is any doubt about the system power budget please check it at this time. Exceeding the power budget can cause unpredictable results which can cause damage and injury. Verify the modules in the base operate within the power budget for the chosen base. You can find these tables in Chapter 4, System Design and Configuration.**

### Run Indicator



430 440 450

If the CPU will not enter the run mode (the RUN indicator is off), the problem is usually in the application program unless the CPU has a fatal error, in which case the CPU LED should be on.

- If you are attempting to enter the run mode by a programming device and the CPU will not enter the run mode, first make sure the key switch is in the TERM position and then try to enter the run mode.
- If you are using the keyswitch to change to RUN mode and the CPU does not respond, attach a programming device to diagnose what error is being returned.
- If the indicator is flashing, the CPU is in firmware upgrade mode.

Both of the programming devices, handheld programmer and **DirectSOFT**, will return a error message and depending on the error may also recommend an AUX function to run that will aid in further diagnosing the problem. The most common programming error is "Missing END Statement". All application programs require an END statement for proper termination. Appendix B lists all the error codes.

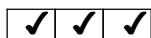
**CPU Indicator**

430 440 450

If the CPU indicator is on, a fatal error has occurred in the CPU. Generally, this is not a programming problem but an actual hardware failure. You can power cycle the system to clear the error. If the error clears, the system should be closely monitored and every effort should be made to try to determine the cause of the problem. You will find this problem is sometimes caused by high frequency electrical noise introduced into the CPU from a outside source. Check your system grounding and install electrical noise filters if the grounding is suspected. If power cycling the system does not reset the error or if the problem returns, replace the CPU.

**BATT Indicator**

430 440 450

If the BATT indicator is on or flashing, either or both the CPU/Memory Cartridge batteries are low (2.5V or less). The DL430 does not have a memory cartridge. The battery voltage is continuously monitored while the system voltage is being supplied.

BATT LED Status	Error Condition
Flashing at 2Hz	CPU battery is low
Flashing at 0.5 Hz	Memory Cartridge battery is low
ON constantly	Both the CPU and Memory Cartridge batteries are low

Procedures for how to replace either of the batteries can be found in the Hardware Maintenance section earlier in this chapter.

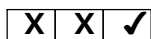
**DIAG Indicator**

430 440 450

The diagnostics indicator is normally off. It turns on if the CPU detects a failure of its run-time diagnostics. Extreme electrical noise may cause a diagnostics failure, so power cycle the CPU first. If the DIAG indicator still turns on, the CPU is probably faulty. Replace it with a known good one to be sure.

**I/O Indicator**

430 440 450

If this indicator is on, a problem in the local, expansion, or remote I/O chain has been detected. Any of the problems listed below could be the cause of the I/O LED being on:

- A blown fuse inside an I/O module
- A loose terminal block
- The 24 VDC supply has failed
- The module or Expansion unit has failed
- The I/O configuration check detects a change in the I/O configuration

I/O error detection for remote I/O will be covered in the DL405 Remote and Slice I/O manual.

To aid you in further diagnosing where the I/O error is, each I/O module has LEDs to indicate if an error is present. The discrete I/O modules covered in this manual may have a combination of the following I/O indicators:

Indicator	Error condition
TB	Loose or missing terminal block
24V	External 24V power supply not providing the correct voltage
FU	Module fuse has blown, (check the I/O modules specification sheets to see if the fuse is replaceable)

Many other specialty modules also have indicators. The manuals for those products contain information on the indicators and status LEDs.

If the modules are not providing any clues to the problem, run AUX 42 from the handheld programmer or I/O diagnostics in **DirectSOFT**. Both options will provide the base number, the slot number and the problem with the module. Once the problem is corrected the indicators will reset.

An I/O error will not cause the CPU to switch from the run to program mode, however there are special relays (SPs) available in the CPU which will allow this error to be read in ladder logic. The application program can then take the required action such as entering the program mode or initiating an orderly shutdown. The following figure shows a example of the failure indicators.

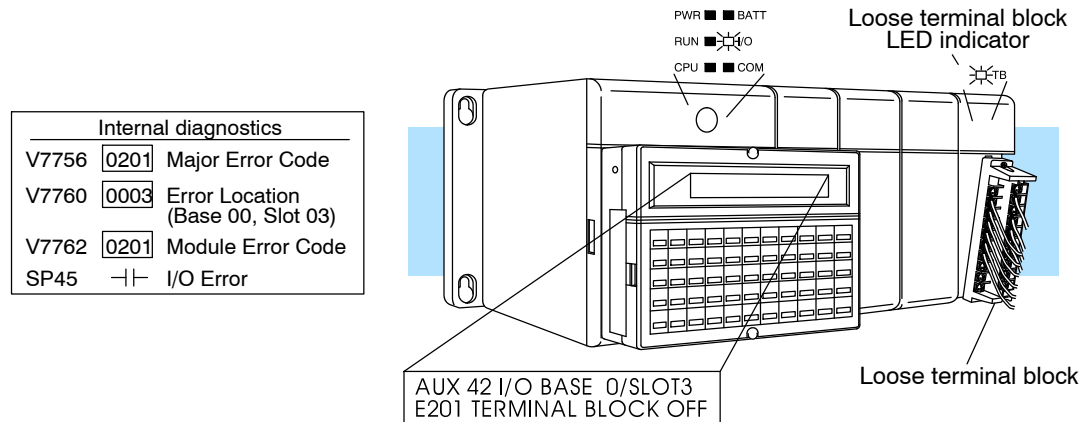

**COM Indicator**

✓	✓	X
430	440	450

The COM indicator on DL430 and DL440 CPU turns ON when the CPU has detected a communication error on one of the two communication ports built into the CPU. The most common causes for this error are:

- The cable is disconnected.
- The cable has a broken wire or has been wired incorrectly.
- The cable is improperly terminated or grounded.
- The device connected to the port is sending data incorrectly.
- A grounding difference exists between the two devices.
- Electrical noise is causing intermittent errors
- The CPU has a bad communication port and the CPU should be replaced

If an error occurs the indicator will come on and stay on until a successful communication has been completed. If the cable and its connections are OK, try doing a power cycle on the devices at both ends of the communications cable.

**TXD and RXD Indicators**

X	X	✓
430	440	450

The TXD and RXD indications on the DL450 CPU work like the identically-named LED indicators found on modem devices. The TXD and/or RXD indicators turn ON whenever the CPU either transmits or receives data, respectively. If the indicator(s) remain off when you are expecting communications, there is a problem.

The TXD and RXD indicators turn on when data is transmitted on any of the four ports on the DL450. Therefore, when **DirectSOFT**, or a HPP, or an operator interface such as the DV-1000 is connected, the TXD and RXD are on constantly. If you are trying to detect communications originated by the ladder program itself, it may be useful to disconnect the programming device or operator interface. In this way, only the cable for the communications you are debugging is connected.



## I/O Module Troubleshooting

**Possible Causes** If you suspect an I/O error, there are several things that could be causing the problem.

- I/O configuration error on modules such as analog I/O, high-speed counting, specialized communications, and so on
- A blown fuse in your machine or panel (the DL105 does not have internal I/O fuses)
- A loose terminal block
- The auxiliary 24 VDC supply has failed
- An Input or Output point has failed

**Some Quick Steps** When troubleshooting the DL series I/O modules there are a few facts you should be aware of. These facts may assist you in quickly correcting an I/O problem.

- The output modules cannot detect shorted or open output points. If you suspect one or more points on a output module to be faulty, measure the voltage drop from the common to the suspect point. Remember when using a Digital Volt Meter, leakage current from an output device such as a triac or a transistor must be considered. A point which is off may appear to be on if no load is connected to the point.
- The I/O point status indicators on the modules are logic side indicators. This means the LED which indicates the on or off status reflects the status of the point with respect to the CPU. On a output module the status indicators could be operating normally while the actual output device (transistor, triac etc.) could be damaged. With an input module if the indicator LED is on, the input circuitry should be operating properly. Verify the LED goes off when the input signal is removed.
- Leakage current can be a problem when connecting field devices to I/O modules. False input signals can be generated when the leakage current of an output device is great enough to turn on the connected input device. To correct this install a resistor in parallel with the input or output of the circuit. The value of this resistor will depend on the amount of leakage current and the voltage applied but usually a 10K to 20K ohm resistor will work. Verify the wattage rating of the resistor is correct for your application.
- The fuse blown indicator on a output module will indicate a problem only if an output point is connected to a load and the point is turned on. This indicator works by sensing a voltage drop across the fuse so there must be a voltage applied to the fuse and a load applied to the output to create the voltage drop before it can be reported by the module.
- The easiest method to determine if a module has failed is to replace it if you have a spare. However, if you suspect another device to have caused the failure in the module, that device may cause the same failure in the replacement module as well. As a point of caution, you may want to check devices or power supplies connected to the failed module before replacing it with a spare module.

**Testing Output Points**

Output points can be set on or off in the DL405 series CPUs but they cannot be forced in such a way to override ladder logic. If you want to do an I/O check out independent of the application program, follow the procedure below:

Step	Action
1	Change the CPU keyswitch to TERM.
2	Use a handheld programmer or <i>DirectSOFT</i> to communicate online to the PLC.
3	Change to Program mode.
4	Go to address 0.
5	Insert an "END" statement at address 0. (This will cause program execution to occur only at address 0 and prevent the application program from running and turning I/O points on or off).
6	Change to Run mode using the handheld programmer or <i>DirectSOFT</i> . We must do this to enable the outputs.
7	Use the programming device to set (turn) on or off the points you wish to test.
8	When you finish testing I/O points delete the "END" statement at address 0.



**WARNING:** Depending on your application, forcing I/O points may cause unpredictable machine operation that can result in a risk of personal injury or equipment damage. Make sure you have taken all appropriate safety precautions prior to testing any I/O points.

**Handheld Programmer Keystrokes Used to Test an Output Point**

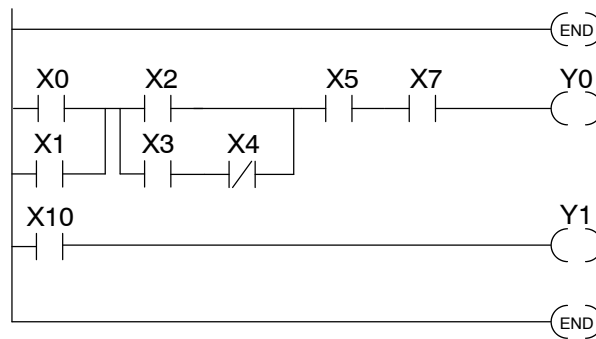

Insert an END statement at the beginning of the Program. This disables the remainder of the program.

From a clear display, use the following keystrokes

Y(OUT) 0 BIT ST

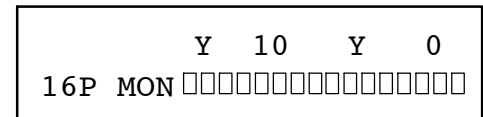

Turn the output on (or off)

Y(OUT) 0 SHFT ON

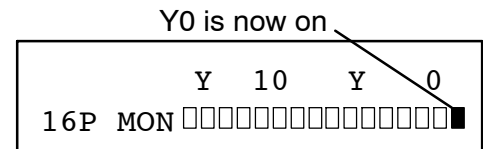

## Noise Troubleshooting

### Electrical Noise Problems

Noise is one of the most difficult problems to diagnose. Electrical noise can enter a system in many ways, which are divided into two categories, conducted or radiated:

- Conducted noise is when the electrical interference is introduced into the system by way of an attached wire, panel connection, etc. It may enter through an I/O module, a power supply connection, the communication ground connection, or the chassis ground connection.
- Radiated noise is electrical interference introduced into the system through the air as radio waves, without a direct electrical connection.

### Reducing Electrical Noise

The following tips can help reduce electrical noise enough for normal operation.

- Most noise problems result from improper grounding of the system. A good earth ground can be the single most effective way to correct noise problems. If a ground is not available, install a ground rod as close to the system as possible. Ensure all ground wires are single point grounds and are not daisy chained from one device to another. Ground metal enclosures around the system. A loose wire is no more than a large antenna waiting to introduce noise into the system; therefore, you should tighten all connections in your system. Loose ground wires are more susceptible to noise than the other wires in your system. Review Chapter 2 Installation and Safety Guidelines if you have questions regarding how to ground your system.
- Electrical noise can enter the system through the power source for the CPU and I/O. Installing an isolation transformer for all AC sources can correct this problem. DC sources should be well grounded, good quality supplies. Switching DC power supplies commonly generate more noise than linear supplies.
- Separate input wiring from output wiring. Never run analog I/O wiring or low voltage discrete I/O wiring close to high voltage wiring.
- To improve noise immunity, you may optionally install the factory provided shunt between logic ground (LG) and chassis ground (G) on the CPU terminal strip shown to the left.
- In rare instances you may want to isolate logic ground from chassis ground. There is a single jumper on the 4 slot base and two jumpers on the 6 and 8 slot bases for this purpose. Isolation can be obtained by removing these jumper(s), shown below.

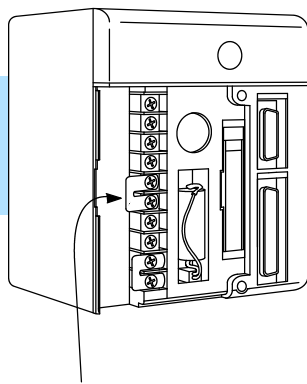

Optional CPU jumper connects logic ground and chassis ground

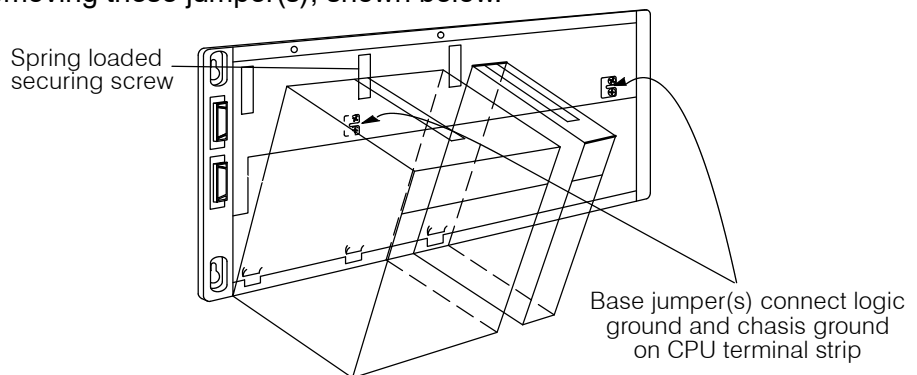

# Machine Startup and Program Troubleshooting

The DL405 CPUs provide several features that can help you debug your program before and during machine startup. This section discusses the following topics which can be very helpful.

- Program Syntax Check
- Duplicate Reference Check
- Test Modes
- Run Time Edits
- Special Instructions

## Syntax Check

Even though the Handheld Programmer and **DirectSOFT** provide error checking during program entry, you may want to check a program that has been modified. Both programming devices offer a way to check the program syntax. For example, you can use AUX 21, CHECK PROGRAM to check the program syntax from a Handheld Programmer, or you can use the PLC Diagnostics menu option within **DirectSOFT**. This check will find a wide variety of programming errors. The following example shows how to use the syntax check with a Handheld Programmer.

Use AUX 21 to perform syntax check

CLR    AUX    2    1    ENT    ENT  
              

```
AUX 21 CHECK PROGRAM
1:SYN 2:DUP REF
```

Select syntax check

1    ENT (This may take a minute or so.)  
  

```
BUSY
```

One of two displays will appear

Error Display (example)

```
$ 8 E401 MISSING END
TMRA    T 002    K00050
(shows location in question)
```

Syntax OK display

```
NO SYNTAX ERROR
?
```

If you get an error, see the Error Codes Section for a complete listing of programming error codes. Correct the problem and continue running the Syntax check until the NO SYNTAX ERROR message appears.

### Duplicate Reference Check

You can also check for multiple uses of the same output coil. Both programming devices offer a way to check for this condition. For example, you can AUX 21, CHECK PROGRAM to check for duplicate references from a Handheld Programmer, or you can use the PLC Diagnostics menu option within **DirectSOFT**. The following example shows how to perform the duplicate reference check with a Handheld Programmer.

Use AUX 21 to perform syntax check

AUX 2 1 ENT ENT

```
AUX 21 CHECK PROGRAM
1:SYN 2:DUP REF
```

Select Duplicate Reference check

2 ENT (This may take a minute or so.)

```
BUSY
```

One of two displays will appear

Error Display (example)

```
$ 12 E471 DUP COIL REF
OUT Y 0000
```

(shows location in question)

Syntax OK display

```
NO DUP REFS
?
```

If you get a Duplicate Reference error, correct the problem and continue running the Duplicate Reference check until no duplicate references are found.

**NOTE:** You can use the same coil in more than one location, especially in programs that use the Stage instructions and / or the OROUT instructions. The Duplicate Reference check will find these outputs even though they may be used in an acceptable fashion.



**TEST-PGM and TEST-RUN Modes**

Test Mode allows the CPU to start in TEST-PGM mode, enter TEST-RUN mode, run a fixed number of scans, and then return to TEST-PGM mode. You can select from 1 to 65,535 scans. You can select this operation from either the Handheld Programmer (AUX 12) or *DirectSOFT* via a PLC Modes menu option.

With the Handheld, the actual mode entered when you first select Test Mode depends on the mode of operation at the time you make the request. If the CPU is in RUN mode, then TEST-RUN is entered. If the mode is PGM, then TEST-PGM is entered. *DirectSOFT* provides more flexibility in selecting the various modes with different menu options. The following example shows how you can use the Handheld to select the Test Modes

Use AUX 12 to enter Test Mode

AUX 1 2 ENT ENT

MODE = TEST-PGM

To specify the number of scans. . .

CLR 1 SHFT TEST

NO. OF SCANS?

(CPU runs scans and returns to Test-PGM)

To switch to TEST-PGM mode . . .

CLR 2 SHFT TEST

STOP SCAN?

ENT  (to confirm the return to TEST-PGM)

To switch to TEST-RUN mode . . .

CLR 3 SHFT TEST

START SCAN?

ENT  (to confirm the entry of TEST-RUN)

With the Handheld Programmer you gain some advantages by using Test Mode.

- The Handheld Programmer status displays are more detailed.
- You can enable the CPU to hold output states.

**Test Mode Displays:** For some instructions, the TEST-RUN mode display is more detailed than the status displays shown in RUN mode. The following diagram shows an example of a Timer instruction display during TEST-RUN mode.

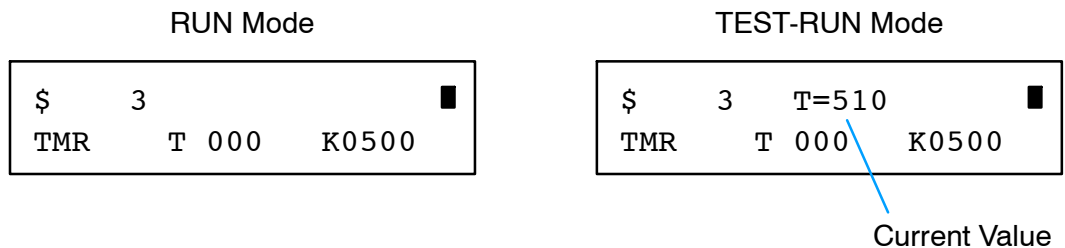

**Holding Output States:** In normal RUN mode, the outputs are turned off when you return to PGM mode. In TEST-RUN mode you can set each individual output to either turn off or hold its last output state on the transition to TEST-PGM mode. The ability to hold the output states is especially useful, since it allows you to maintain key system I/O points for examination. The following diagram shows the differences between RUN and TEST-RUN modes.

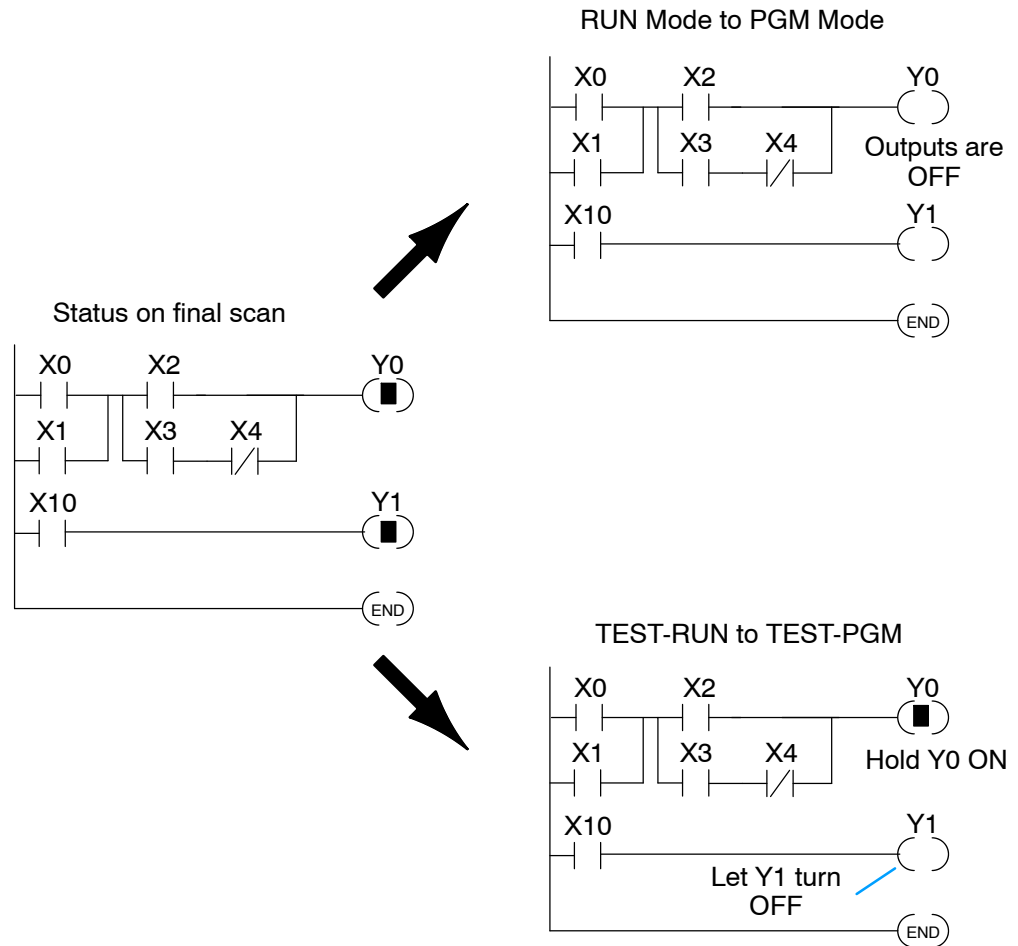

You can use AUX 58 on the Handheld Programmer to select the action for each individual output.

**Run Time Edits**

X ✓ ✓  
430 440 450

The DL440 and DL450 CPUs allow you to make changes to the application program during Run Mode. These edits are not “bumpless.” Instead, CPU scan is momentarily interrupted (and the outputs are maintained in their current state) until the program change is complete. This means if the output is off, it will remain off until the program change is complete. If the output was on, it will remain on.

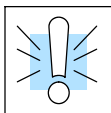

**WARNING: Only authorized personnel fully familiar with all aspects of the application should make changes to the program. Changes during Run Mode become effective immediately. Make sure you thoroughly consider the impact of any changes to minimize the risk of personal injury or damage to equipment. There are some important operations sequence changes during Run Time Edits.**

1. If there is a syntax error in the new instruction, the CPU *will not* enter the Run Mode.
2. If you delete an output coil reference and the output was on at the time, the output will remain on until it is forced off with a programming device.
3. Input point changes are not acknowledged during Run Time Edits. So, if you’re using a high-speed operation and a critical input comes on, the CPU may not see the change.

You can use either the Handheld Programmer or *DirectSOFT* to edit the program during Run Mode. The following pages show a brief example of how to do this with the Handheld Programmer. You use AUX 14 to edit the program during Run Mode. We’ve already shown you how to select the various AUX functions, but a few things are different with AUX 14.

- Once you select AUX 14 the Handheld RUN LED starts blinking. This indicates the a Run Mode edit is in progress.
- If you had displayed an address just before selecting AUX 14, that address will automatically appear. So, you can search for an address or instruction *before* you select AUX 14 or *after* you select AUX 14.

**Select AUX 14, Run Time Edit**

AUX 1 4 ENT

AUX 1\* OPERATING MODE  
 AUX 14 RUN TIME EDIT

**Press ENT to select AUX 14 and display the address**

ENT

\$xxxxxx  
 STR X 0001



### Changing an Instruction During Run Mode

Once you've found the instruction you can change it very easily. The following example shows you how to change the X5 contact to X10.

#### Ladder Representation

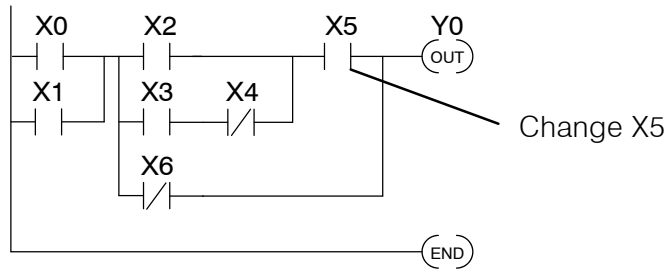

#### Identify the Instruction

ADDRESS	INSTRUCTION	DESCRIPTION
0	STR X0	Starts branch 1 with X0
1	OR X1	Joins X1 in parallel with X0
—	—	—
—	—	—
6	AND X5	Starts branch 4 with X5
—	—	—
—	—	—
10	END	Ends the program

#### FIND the Address

AND X(IN) 5 FIND

SEARCHING  
AND X5

\$ 6  
AND X 0005

#### Change the Instruction

AND X(IN) 10 ENT

\$ 6  
WANT TO ALTER?

#### Press CLR to abort the edit or ENT to accept

ENT  
←

\$ 7  
ORN X 0006

(If you press ENT, the change is accepted and the next address is displayed. If you pressed CLR, the current address is displayed.)

**Inserting an Instruction During Run Mode**

Inserting an instruction during Run Mode works almost exactly the same as it does during Program Mode. Remember, INSERT adds an instruction *before* the instruction that is being displayed and the remaining addresses increment.

**Ladder Representation**

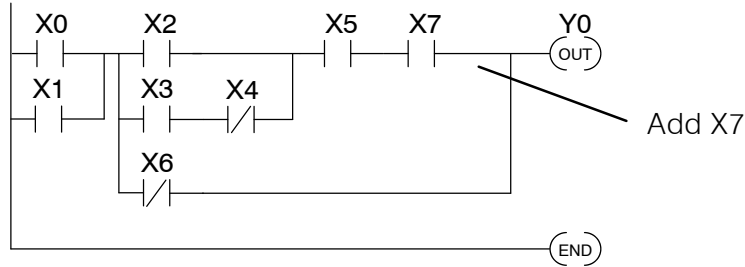

**Identify the Instruction**

ADDRESS	INSTRUCTION	DESCRIPTION
0	STR X0	Starts branch 1 with X0
1	OR X1	Joins X1 in parallel with X0
—	—	—
Insert before 6	AND X5	Starts branch 4 with X5
	AND X7	Adds X7 in series with X5
7	ORN X6	Joins X6 (NOT) in parallel
—	—	—
10	END	Ends the program

**FIND the Address**

OR  NOT  X(IN)  6  FIND

SEARCHING  
ORN X6

\$ 7  
ORN X 0006

**Insert the New Instruction**

AND  X(IN)  7  SHFT  INS

\$ 7  
WANT TO INSERT?

**Press CLR to abort the edit or ENT to accept**

ENT

(If you press ENT, the change is accepted and the next address is displayed. If you pressed CLR, the current address is displayed.)

\$ 8  
ORN X 0006

### Deleting an Instruction During Run Mode

Deleting an instruction during Run Mode works almost exactly the same as it does during Program Mode. Remember, this operation deletes the instruction that is currently being displayed and the remaining addresses decrement.

#### Ladder Representation

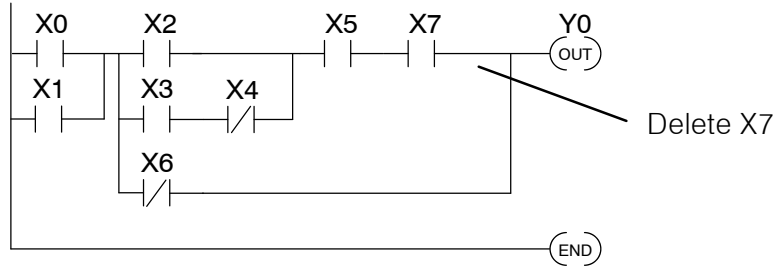

#### Identify the Instruction

ADDRESS	INSTRUCTION	DESCRIPTION
0	STR X0	Starts branch 1 with X0
1	OR X1	Joins X1 in parallel with X0
—	—	—
6	AND X5	Starts branch 4 with X5
7	AND X7	Adds X7 in series with X5
—	—	—
11	END	Ends the program

#### FIND the Address

AND X(IN) 7 FIND

SEARCHING  
AND X7

\$ 7  
AND X 0007

#### Delete the Instruction

SHFT DEL

\$ 7  
WANT TO DELETE?

#### Press CLR to abort the edit or ENT to accept

ENT

\$ 7  
ORN X 0006

(If you press ENT, the change is accepted and the next address is displayed. If you pressed CLR, the current address is displayed.)

**Special Debug Instructions**

There are several instructions that can be used to help you debug your program during machine startup operations: END, PAUSE, STOP, and BREAK.

**END Instruction:** You can quickly disable part of the program by inserting an END statement prior to the portion that should be disabled. The CPU assumes that is the end of the program. The following diagram shows an example.

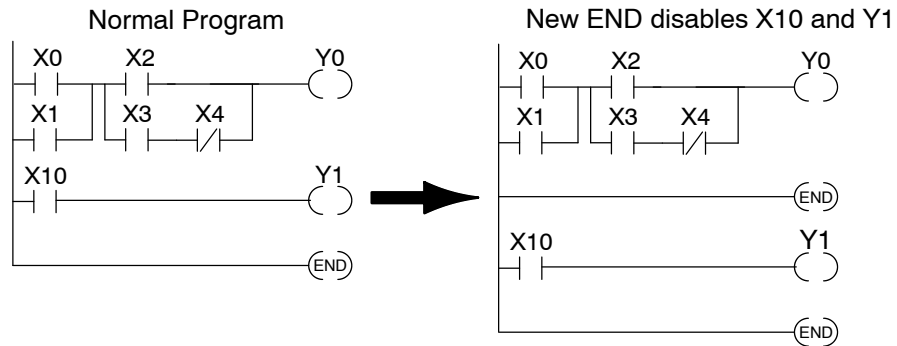

**PAUSE Instruction:** This instruction provides a quick way to allow the inputs (or other logic) to operate while disabling selected outputs. The output image register is still updated, but the output status is not written to the modules. For example, you could make this conditional by adding an input contact or CR to control the instruction with a switch or a programming device. Or, you could just add the instruction without any conditions so the selected outputs are always disabled.

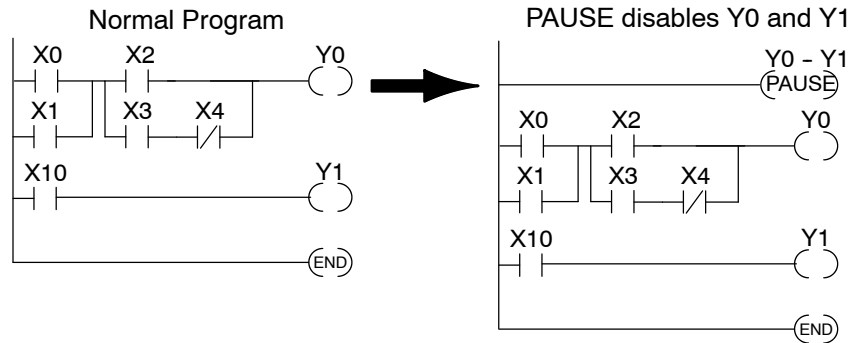

**STOP Instruction:** Sometimes during machine startup you need a quick way to turn off all the outputs and return to Program Mode. In addition to the Test Modes, you can also use the STOP instruction. When executed, a STOP causes the CPU to exit Run Mode and enter Program Mode. The following program does this. Remember, all outputs are turned off during Program Mode.

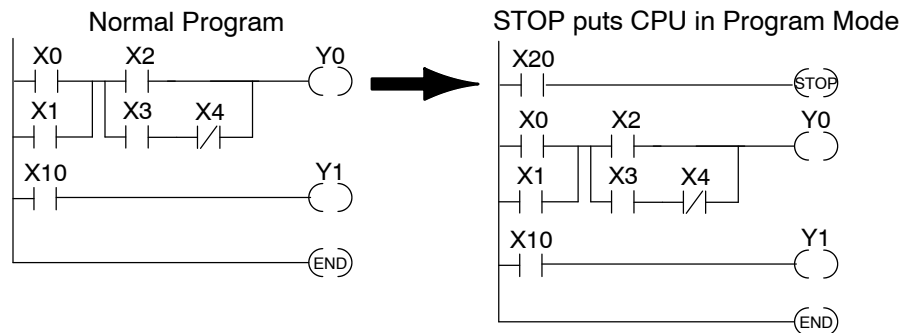

**BREAK Instruction:** If you have a DL440 CPU you can also use the BREAK instruction to stop the program scan. As long as the BREAK instruction is active the scan is stopped and the CPU enters a special mode, TEST-HALT. You have to use either the Handheld Programmer or *DirectSOFT* to restart the scan by placing the CPU back in Run Mode. When the CPU returns to Run Mode the scan resumes at the point of the break. For example, if you are using several data instructions it may be helpful to stop the scan and examine the accumulator and accumulator stack. The following diagram shows an example.

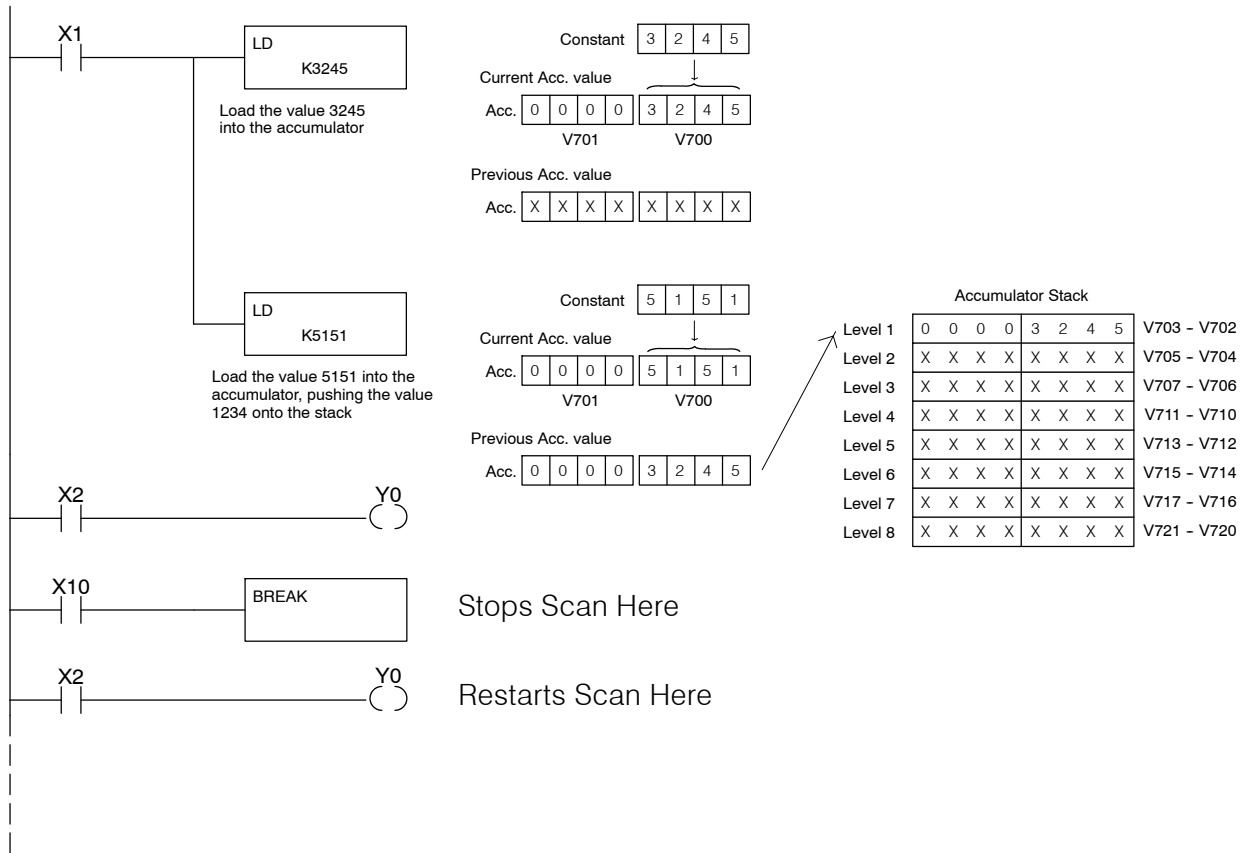

In the example, input X10 triggers the BREAK instruction. The CPU will stop scanning the program at this point. Now you could easily see how the program instructions have affected the accumulator or accumulator stack. The following diagram shows how you could use the Handheld to examine the accumulator stack.

Select the location to monitor



When you use the Handheld to return to Run Mode, the CPU starts scanning the program at the rung following the BREAK.

See the Errata Sheet at the beginning of this file. We added a procedure named "Reset the PLC to Factory Defaults".