

# Installation & Wiring

---

## In This Chapter. . . .

- Introduction
  - Step 1: Set the Baud Rate with the Rear DIP Switches
  - Step 2: Install the Master(s)
  - Step 3: Mount the Slave Units
  - Step 4: Set the Slave Address with the Front Rotary Switch
  - Step 5: Connect the Communications Cable
  - Step 6: Connect the Field Wiring
  - Optional Features
-

## Introduction

---

**NOTE: It is advised that you read the previous chapter on “Designing the Slice I/O System” before you install your Slice master and slave units. The decision making process explained in that chapter will help you understand how you should set the rotary switches and dip switches on the units. It will also help you with writing your ladder logic in the next chapter.**

---

### 6 Steps:

There are six steps to install master module and slave units:

1. Choose the baud rate by setting the dip switch on the rear of the master module and slave units.
2. Disconnect the power and insert the master module(s) into the CPU base.
3. Mount each of the slave units in their remote areas.
4. Set the address for each slave by using the rotary switch on the front of each slave unit.
5. Connect the communication cabling.
6. After making sure the power is turned off, connect the field wiring.

The following pages will cover each of these steps in detail.

This is all that is required to connect the masters and slaves. There are also optional features that you may want to use.

- Master unit Run Relay circuit
- Slave unit communications port

These topics are covered at the end of the chapter.

## Step 1: Set the Baud Rate with the Rear DIP Switches

There are DIP switches on the rear of both the master and slave units. These switches must be set to the same baud rate. You have four choices, but whatever baud rate you select for the master, you must also use for its slaves. Use the table below for setting the switches. Also, if you chose discrete addressing when you designed your system, make sure you check switch 4 on the master. It must be turned on to enable discrete addressing.

Note that in this example, we have turned pos.1 to OFF and pos.2 to ON. 3 is not used and should always be set to OFF. This sets the baud rate to 153.6 kB. Position 4 is OFF unless you plan to use discrete addressing or the slave removal feature explained later.

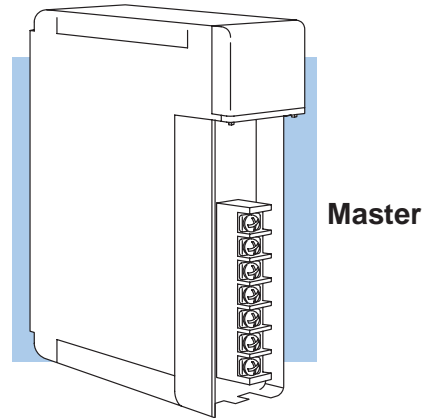
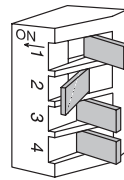

The settings of pos.1 and pos.2 of the slaves must match the ON/OFF state of these same positions on the master module's DIP switch. Otherwise, they will be set at different baud rates and will not be able to communicate.

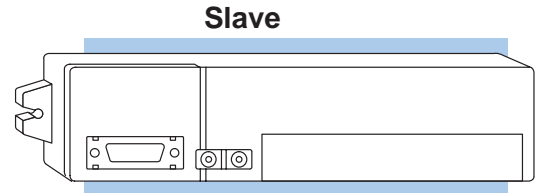
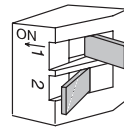

Installation and Wiring

Table for setting DIP switch

Baud Rate		19.2kB	38.4kB	153.6kB	614.4kB
Master	1	OFF	ON	OFF	ON
	2	OFF	OFF	ON	ON
	3	Not used, should always be OFF			
	4	See Note	See Note	See Note	See Note
Remote	1	OFF	ON	OFF	ON
	2	OFF	OFF	ON	ON

**Note:** Position 4 of the Master enables or disables the system's ability to make use of discrete addressing or the automatic slave removal feature:  
**ON**=Features enabled  
**OFF**=Features disabled

## Step 2: Install the Master(s)

You can install up to two masters in the CPU base. These can go into any available slot in the base.

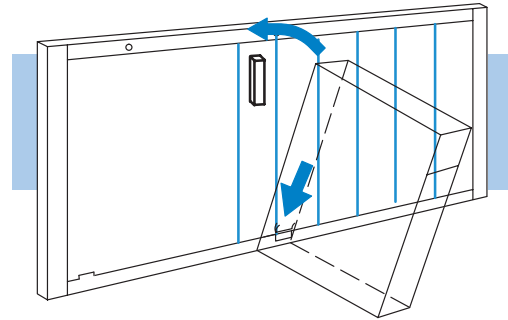

The master can go into any slot in the local base.

**WARNING:** To minimize the risk of electrical shock, personal injury, or equipment damage, always disconnect the system power before installing or removing any system component.

Notice the master module has plastic tabs at the bottom and a screw at the top. With the module tilted slightly forward, hook the plastic tab on the module into the notch on the base. Next, gently push the top of the module back toward the base until it is firmly seated into the base. Now tighten the screw at the top of the module to secure the module to the base.

## Step 3: Mount the Slave Units

Each slave unit is 202mm in width, 45mm in height and 70mm in depth. The slave units have flanges located on each side for using mounting screws to attach them to a wall or mounting plate. These mounting holes are located 192 mm apart (from center to center). The mounting screws do not come with the slave units. Remember that the slave units cannot be located more than 1000 feet from the local base.

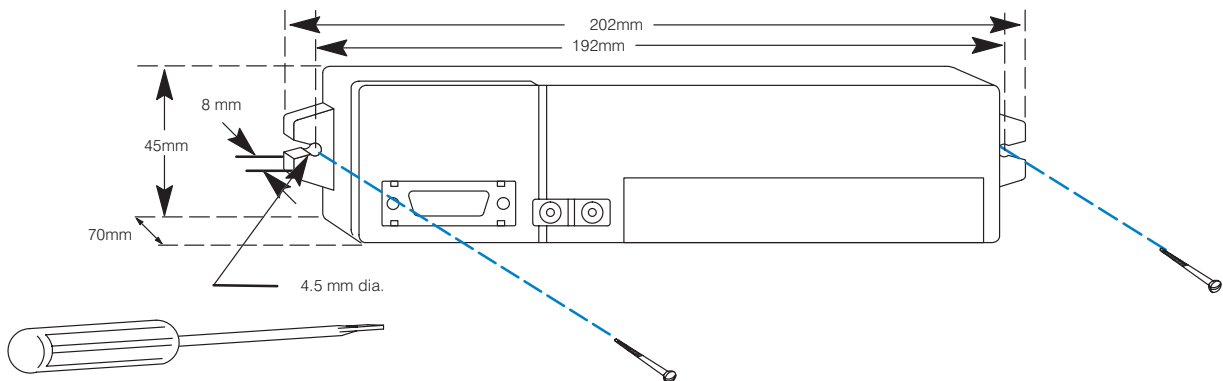

## Step 4: Set the Slave Address with the Front Rotary Switch

The Slice slave units have two small rotary switches on the front of their enclosure. One switch is marked X1 and the other X10. Don't confuse these with the conventional data type labeling—*these do not refer to inputs X1 and X10*. Instead, these set the unit address in decimal for each slave. X1 is the “one's” position and X10 is the “tens” position. For example, 13 is set by turning the X10 switch to 1 and the X1 switch to 3 ( $10 + 3 = 13$ ). Since each Slice channel operates independently of the other, you start the unit addressing for the 1st Master's slaves at 01, and you start the unit addressing for the 2nd Master's slaves also at 01.

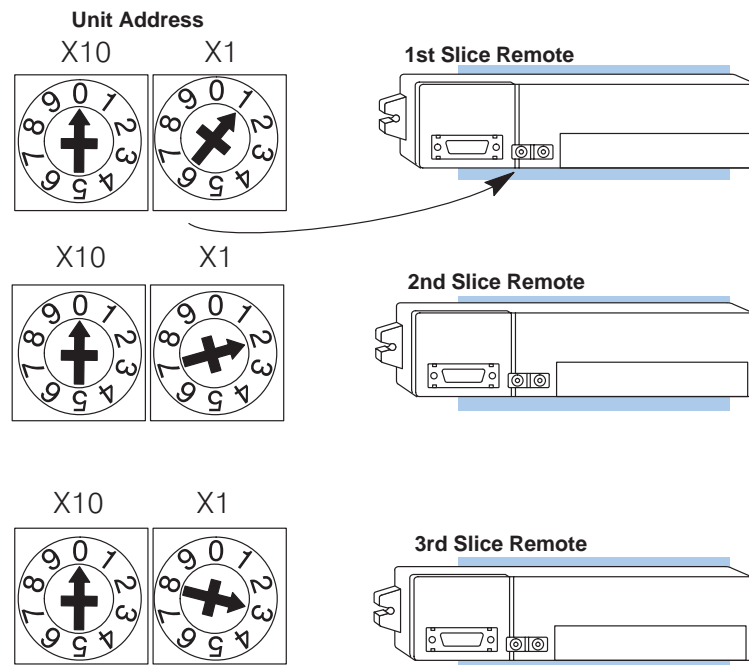

Align the arrow on the switch to any numbers between 01 and 15 (decimal), depending on which slave in sequence you are setting up and how many slaves are allowed per master. Remember, each addressing mode (automatic, manual and discrete) has a particular limit on how many slaves can be connected to the master.

**NOTE: Always use consecutive numbers for slaves and always start with Address 01 (not 00)—don't skip numbers.**

**Example Showing Proper Setting of Switches**

Here's the way Steps 3 and 4 would be carried out for a system with one master and three slaves set to communicate at 153.6 kB:

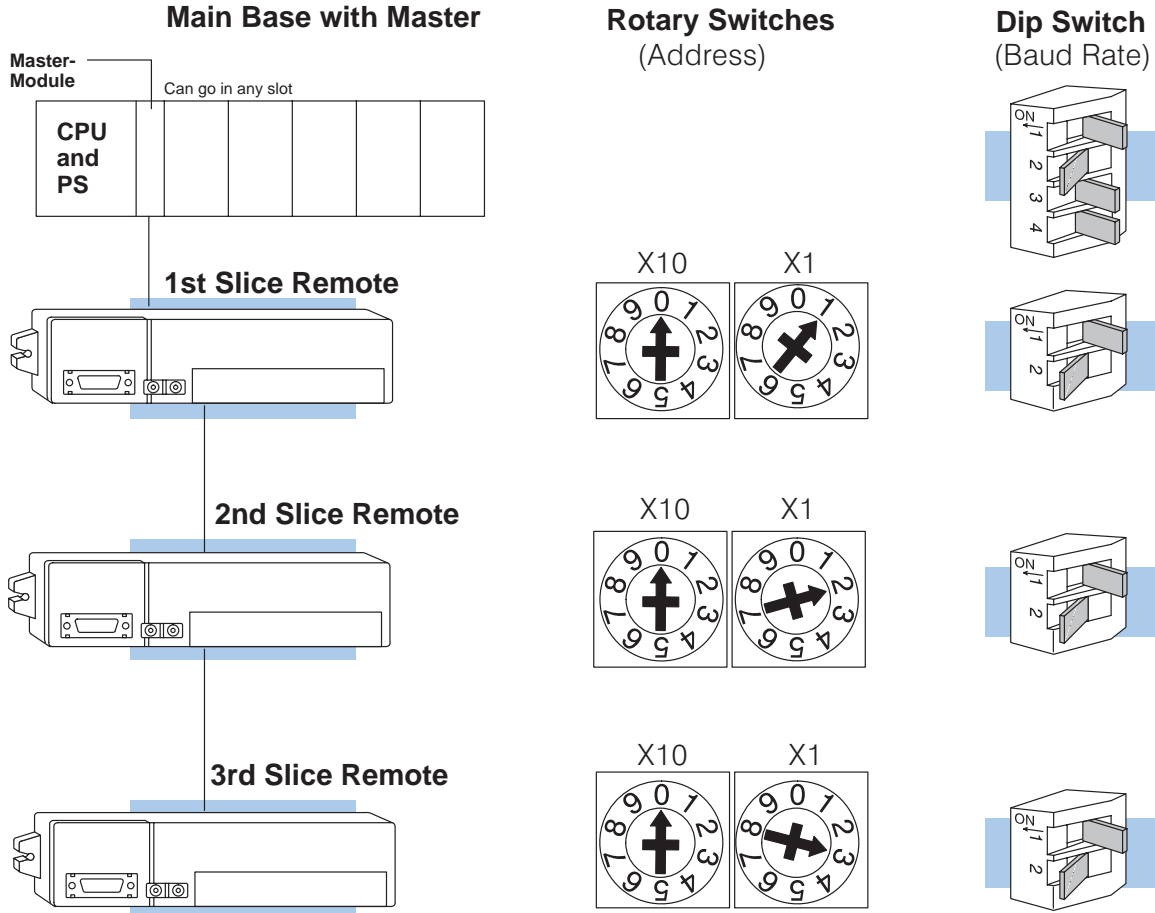

Installation and Wiring

**Note:** Position 4 of the Master enables or disables the system's ability to make use of discrete addressing or the automatic slave removal feature:  
**ON**=Features enabled  
**OFF**=Features disabled.

**Table for setting DIP switch**

Baud Rate		19.2kB	38.4kB	153.6kB	614.4kB
<b>Master</b>	1	OFF	ON	OFF	ON
	2	OFF	OFF	ON	ON
	3	Not used, should always be OFF			
	4	See Note	See Note	See Note	See Note
<b>Remote</b>	1	OFF	ON	OFF	ON
	2	OFF	OFF	ON	ON

## Step 5: Connect the Communications Cable

### Cabling Between the Master and Slaves

The following diagram shows the cabling between the master and its slaves. We recommend Belden 9841 or its equivalent for connecting the Master and Slaves. This is twisted pair cable. The two inner wires are connected to terminals 1 and 2 of each module. The shield wire is connected to terminal 3 of each module.

**NOTE:** Do not connect the shield wire to the Ground terminal. Make sure the connections between master and all slaves are always 1 to 1, 2 to 2 and 3 to 3.

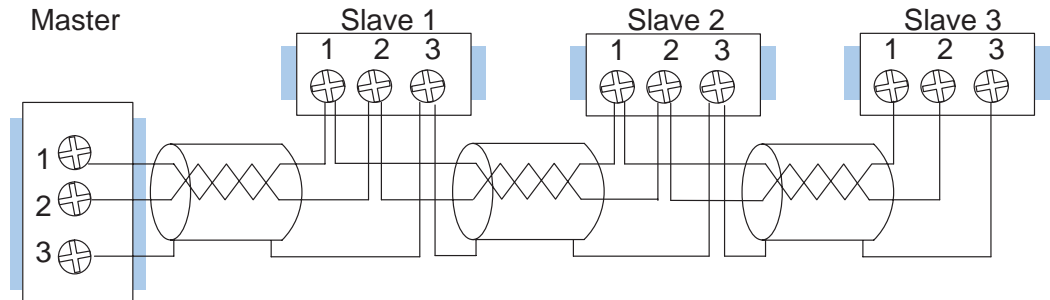

### Termination Resistors

At each end of a master/slave system, it is necessary to have a “termination resistor” to prevent signal reflections from interfering with the communications. Although the modules have a 150 ohm resistor built in for this purpose, there are three options to consider.

- Use the internal resistor
- Use an external resistor
- Use an external resistor in series with the internal resistor.

The following diagrams show these options in more detail.

#### Option 1: Use Internal Resistor Only

With this configuration, you use the internal resistor of the module to provide all the terminating resistance necessary. A jumper wire is placed between the terminating terminal and terminal 1.

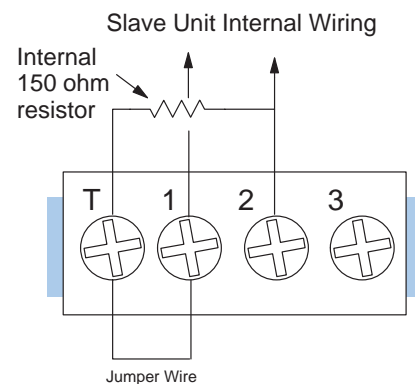

**Option 2:  
Use an External Resistor**

To better match the impedance of the cabling, you can elect not to use the internal resistor; and instead, use an external resistor of your choice. This is connected between terminals 1 and 2. You **do not** use the jumper wire in this case.

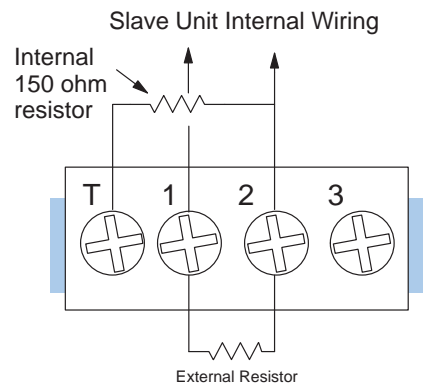

You add your own resistor, using a resistor between 100 and 300 ohms to match the impedance of the cable.

**Option 3:  
External Resistor in Series**

With this option, you use an external resistor in series with the internal resistor. The series resistance should match the cabling impedance.

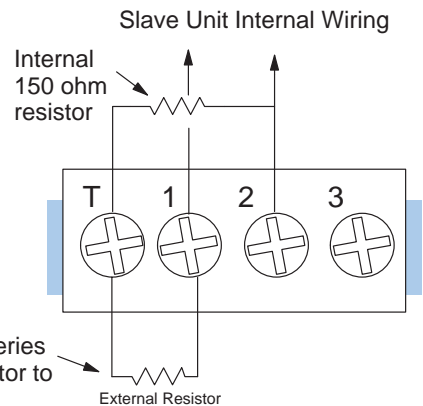

You add your own resistor in series with the 150 ohm internal resistor to match the cable impedance.



## Step 6: Connect the Field Wiring

### General Wiring Guidelines

You should consider the following wiring guidelines when wiring your system.

1. There is a limit to the size of wire the modules can accept. 16 AWG to 24 AWG is recommended. Smaller AWG is acceptable.
2. Always use a continuous length of wire, do not combine wires to attain a needed length.
3. Use the shortest possible cable length.
4. Where possible, use wire trays for routing.
5. Avoid running wires near high energy wiring.
6. Avoid running input wiring in close proximity to output wiring where possible.
7. To minimize voltage drops when wires must run a long distance, consider using multiple wires for the return line.
8. Where possible, avoid running DC wiring or communication cabling in close proximity to AC wiring.
9. Avoid creating sharp bends in the wires.
10. Label all wires.

### Power Connections for the Master and Its Slaves

The master module is powered through the backplane of the local base. The slaves, however, require an external 24VDC power supply. *The Slave units will not operate unless this supply is connected.*

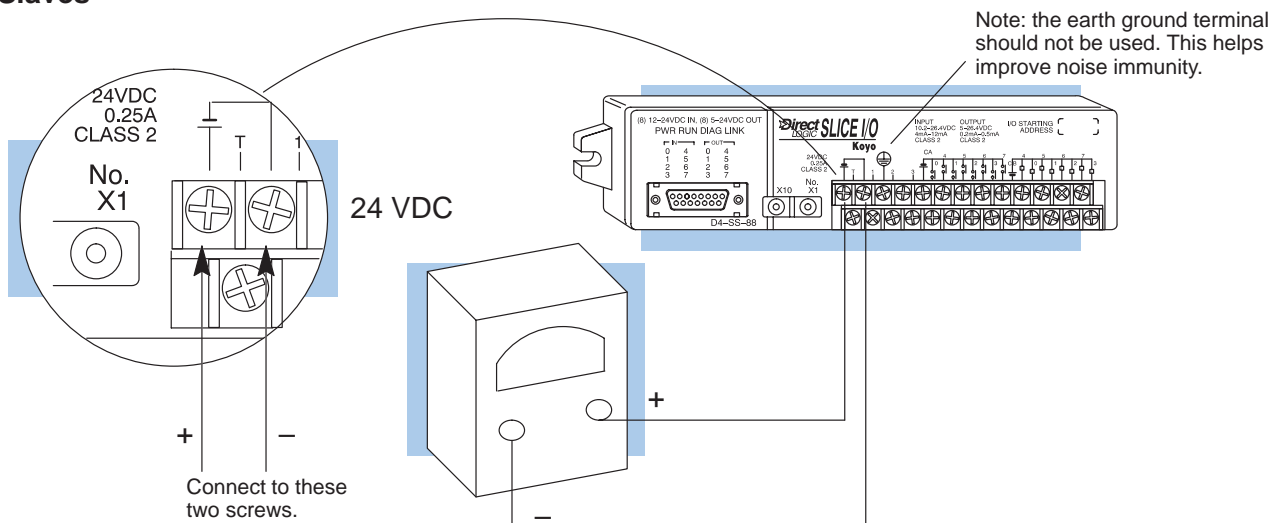

**NOTE:** If you are using 24VDC for your input and/or output field devices, it may be possible to use the above power supply for the field power as well. If you use the same supply, make sure you have calculated the maximum load required and that you size the power supply accordingly.

### D4-SS-88 I/O Field Device Wiring Diagram

Use the following wiring diagram to connect the field wiring to the I/O terminal strip. The I/O point addresses have been labeled "Xn" and "Yn" to indicate the starting address. The X and Y data types have only been used for illustration purposes. Your exact starting addresses and data types depend on the addressing mode selected.

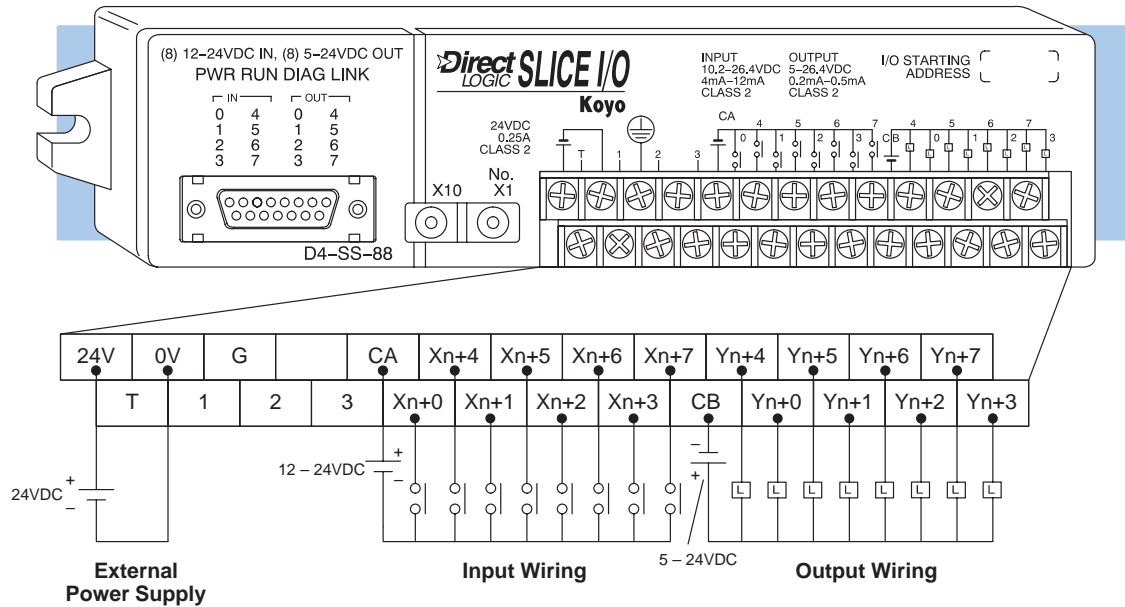

**Solid State NPN  
Field Device Wiring**

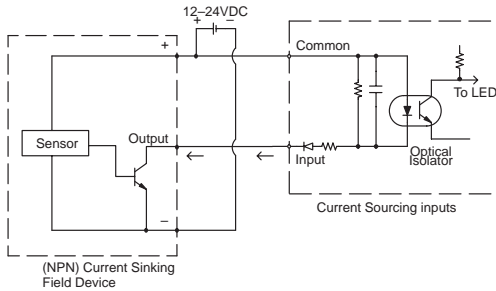

**Typical Input Circuit**

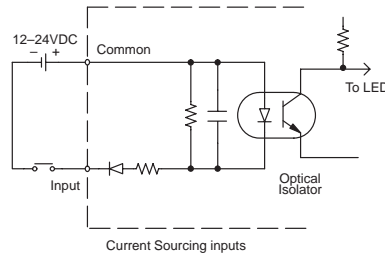

**Typical Output Circuit**

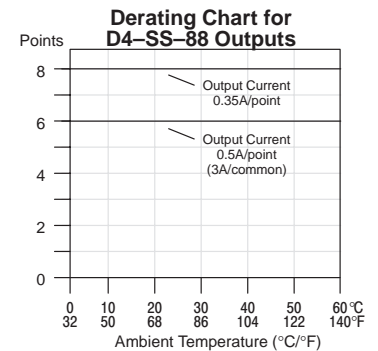
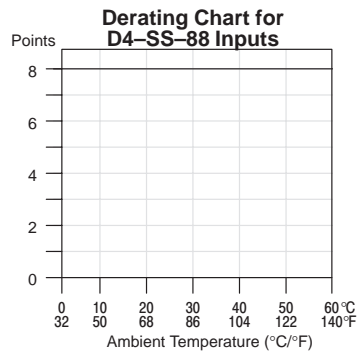
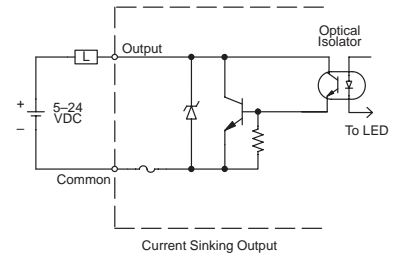

**D4-SS-106**  
I/O Field Device  
Wiring Diagram

Use the following wiring diagram to connect the field wiring to the I/O terminal strip. The I/O point addresses have been labeled “Xn” and “Yn” to indicate the starting address. The X and Y data types have only been used for illustration purposes. Your exact starting addresses and data types depend on the addressing mode selected.

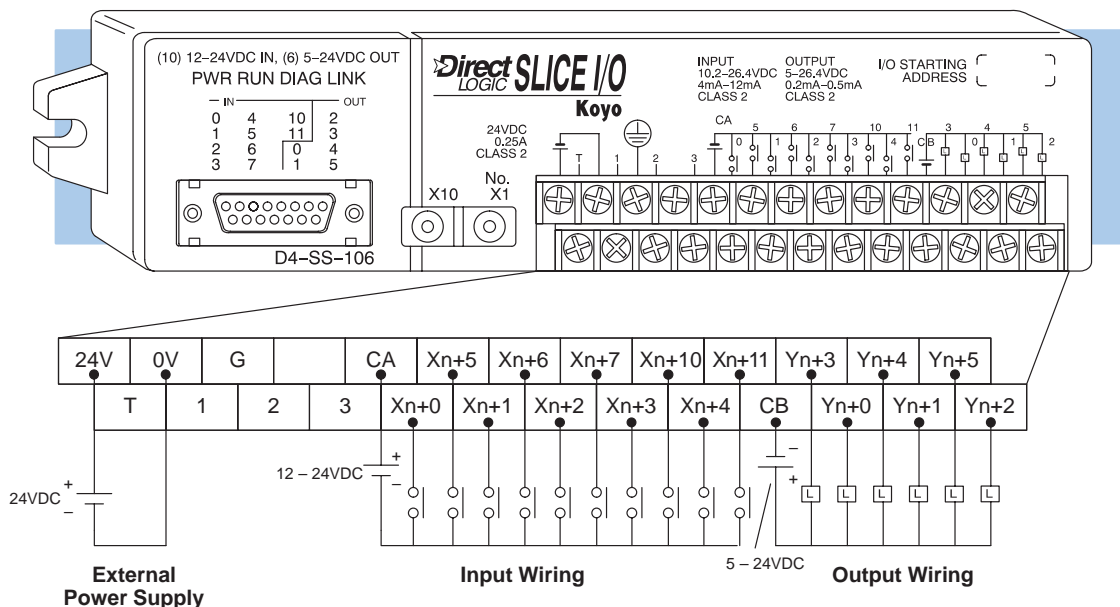

**Solid State NPN Field Device Wiring**

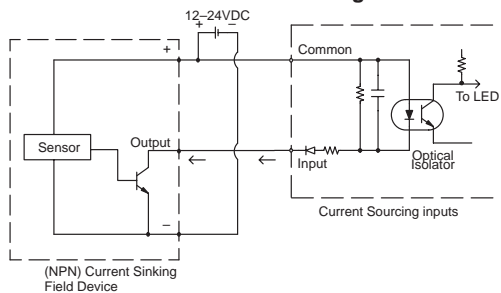

**Typical Input Circuit**

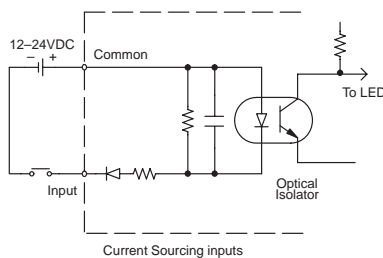

**Typical Output Circuit**

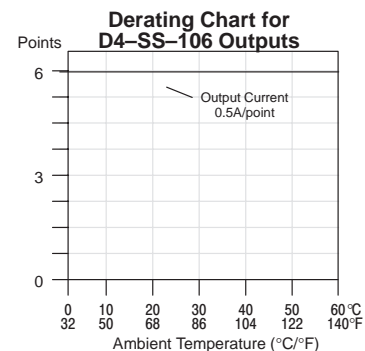
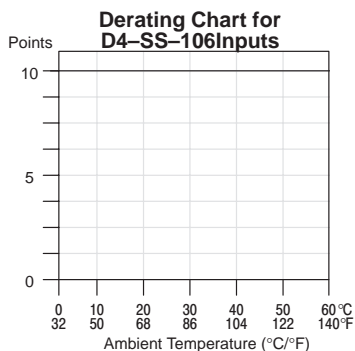
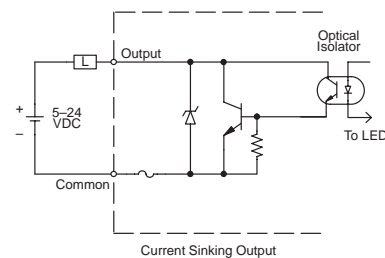

### D4-SS-16N I/O Field Device Wiring Diagram

Use the following wiring diagram to connect the field wiring to the I/O terminal strip. The I/O point addresses have been labeled “Xn” and “Yn” to indicate the starting address. The X and Y data types have only been used for illustration purposes. Your exact starting addresses and data types depend on the addressing mode selected.

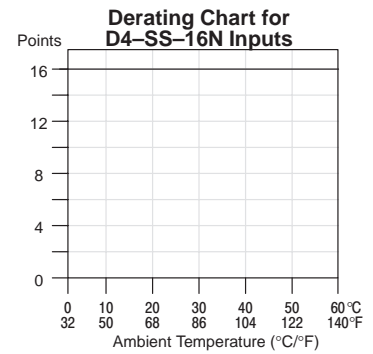
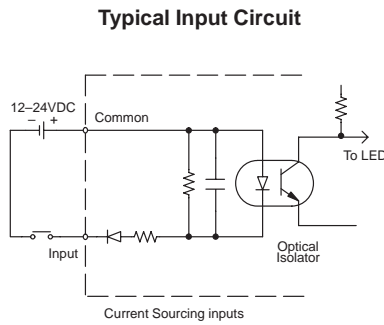
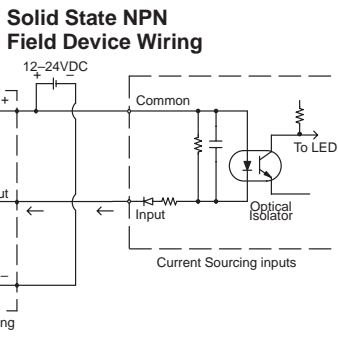
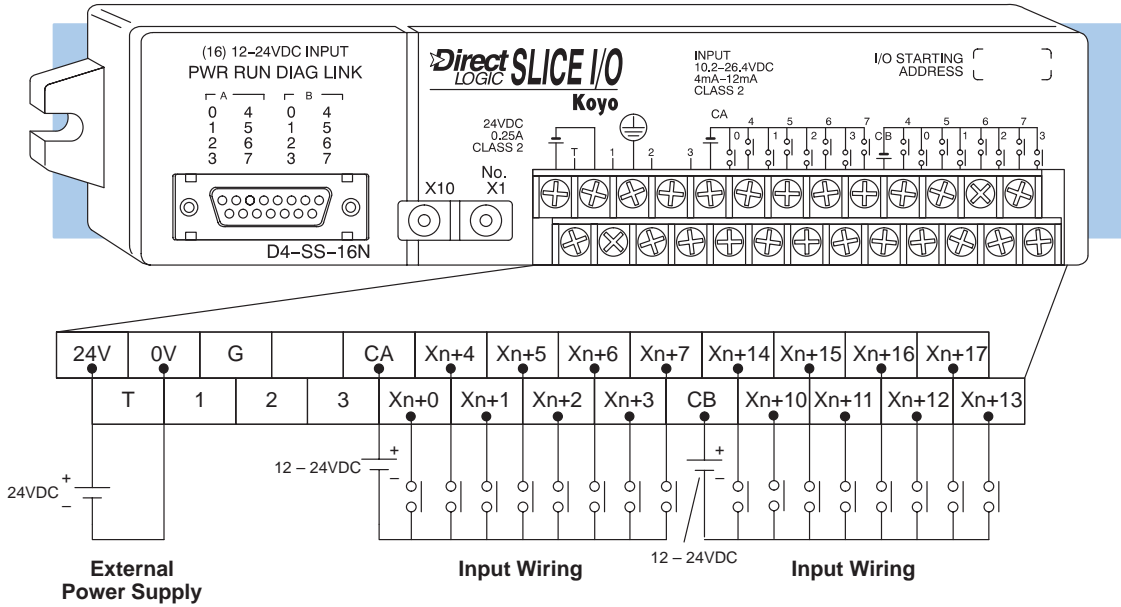

### D4-SS-16T I/O Field Device Wiring Diagram

Use the following wiring diagram to connect the field wiring to the I/O terminal strip. The I/O point addresses have been labeled "Xn" and "Yn" to indicate the starting address. The X and Y data types have only been used for illustration purposes. Your exact starting addresses and data types depend on the addressing mode selected.

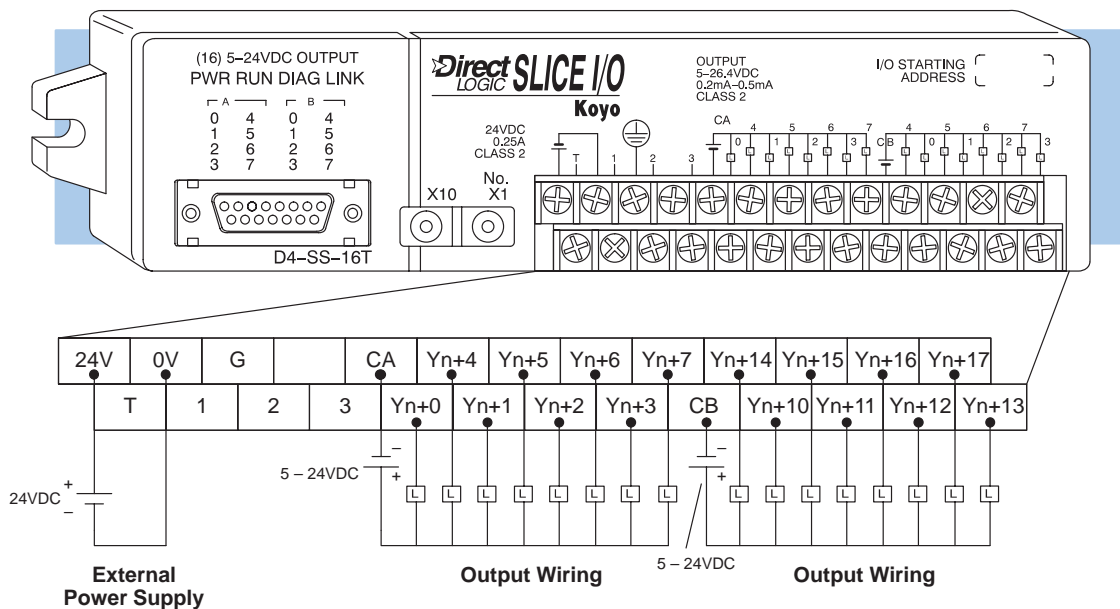

Typical Output Circuit

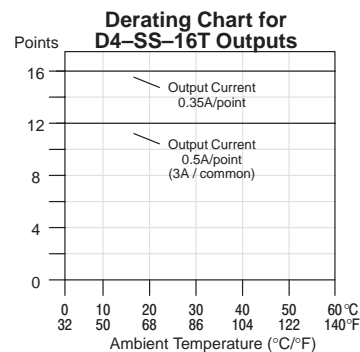
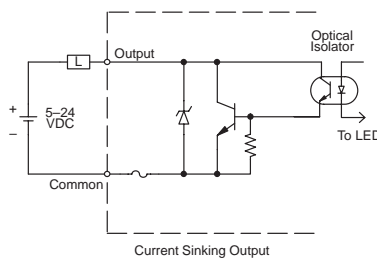

## Optional Features

### Connecting the Run Output Circuit

The master module has a normally open relay that closes when communication is successfully made between the master and its slaves. Each module has its own LED indicator (labeled "LINK") that glows if there is a communications error or no link.

The Run Output relay of the master module can be wired to a 24 VDC sinking input module so that ladder logic can be written to monitor the communications link. The bottom two terminals of the terminal block are where the wires are connected from the input module.

The Run Output relay can handle the following loads.

- 250VAC @ 1.0A
- 30VDC @ 1.0A

If the RUN relay in the master goes OFF, then the RUN relay in all of the slaves will turn off also.

If you choose to wire an input (say, X10) from the Run Output, it is very easy to include a rung of logic to sound an alarm or to stop a process when a communication problem occurs:

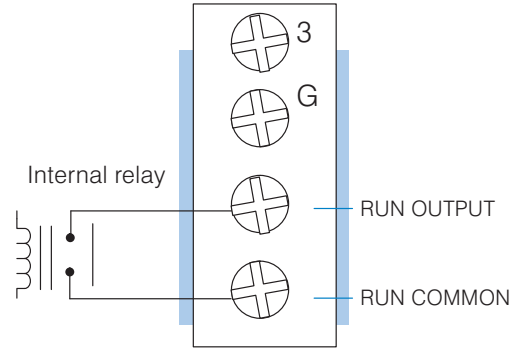

**Using the Slave Unit Communications Port**

Each Slave unit has a 15-pin D-shell communications port. This port is the same as the top port on the DL405 CPUs. You can program or monitor the CPU through this port with *DirectSOFT* or the handheld programmer. You can also connect the DV-1000 Operator Interface to this port. (Note, if you're using the handheld programmer or the DV-1000, remember to add the power requirement for the device when you select your 24VDC power supply.)

You can order the necessary cables with the following part numbers.

- **D4-DSCBL** — *DirectSOFT* Programming cable for the DL405
- **D4-HPCBL-1** — DL405 handheld programmer cable (9.24ft., 3m)
- **D4-HPCBL-2** — DL405 handheld programmer cable (4.6ft., 1.5m)
- **D4-1000CBL** — DV-1000 cable (6.56ft, 2m)

Since the handheld programmer and the DV-1000 obtain their operating power from the Slave unit, we strongly suggest that you use the standard cables for these devices. However, there may be an occasion where you need to quickly make your own programming cable for use with your laptop or personal computer. In this case, use the following cable pinout diagrams.

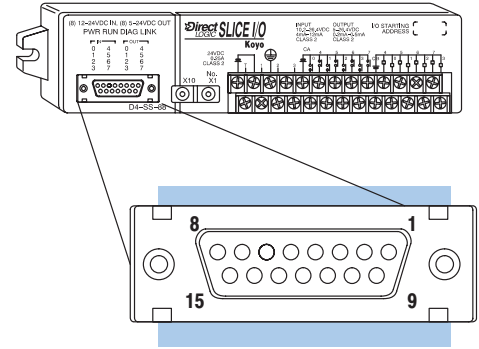

Pin numbers only shown for illustration

15-pin Female RS232C  
 9600 Baud  
 8 Data Bits  
 1 Start Bit  
 1 Stop Bit  
 Odd Parity  
 Half-duplex  
 Asynchronous  
 DTE

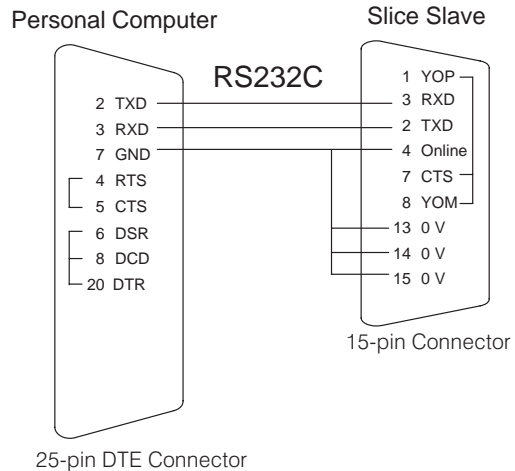
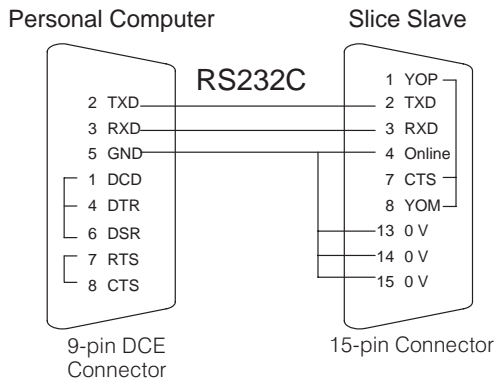

Pin labeling conforms to the IBM DTE and DCE standards.