

System Monitoring and Troubleshooting

In This Chapter. . . .

- Troubleshooting Suggestions
 - Monitoring Discrete I/O Points
 - Forcing Discrete I/O Points
 - Monitoring V-Memory Locations
 - Changing V-Memory Values
 - Monitoring Timer/Counter Values
 - Monitoring the CPU Scan Time
 - Test Modes
 - I/O Diagnostics
 - Custom Messages
 - Checking the Error Message Tables
 - Error Codes
-

Troubleshooting Suggestions

The Handheld is very useful in troubleshooting your machine. As with most any problem, you have to find it before you can fix it. There are several operations and features that help you quickly find the exact cause of system problems.

- Monitor Discrete I/O Points — to examine I/O power flow for individual I/O points.
 - Force Discrete I/O Points — to examine machine sequences or inconsistencies.
 - Monitor V-Memory Locations — to examine word locations to determine if correct values are being used.
 - Change V-Memory Values — to force word locations with different values.
 - Monitor Timer/Counter Values — to adjust machine timing elements.
 - Monitor CPU scan time (in milliseconds) — view the maximum, minimum, and current scan times to adjust scan related problems.
 - Use Test Modes — to run a fixed number of scans and examine output status.
 - Use I/O Diagnostics — to pinpoint I/O errors.
 - Understand Error Codes — to utilize many automatic error checks.
-

Monitoring Discrete I/O Points

You can monitor up to 16 discrete points at one time. The points can be from the following data types.

- X inputs
- Y output
- GX remote I/O points
- C control relays
- Stage bits
- Timer/Counter bits
- Special relays

If you examine the Handheld Programmer display, you will notice several numbers printed at the bottom. These numbers help you identify the point that you need.

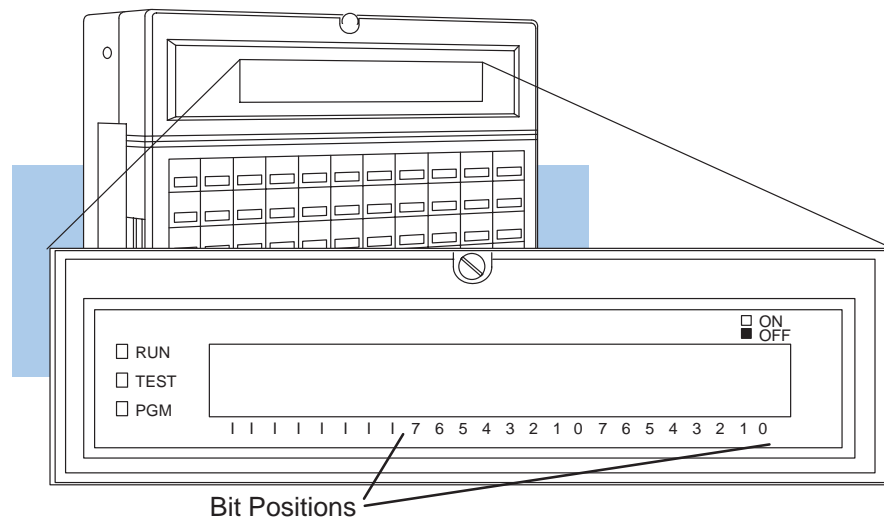

Use the following keystrokes to monitor discrete points. (To select a different data type, use the corresponding Instruction Reference key instead of the one shown.)

Select the data type and range to monitor

X(IN) 0 BIT ST

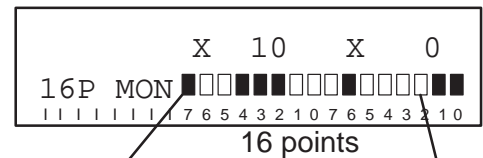

Black indicates ON ■ Blank indicates OFF □

Use the PREV and NXT keys to scroll through additional points

NXT

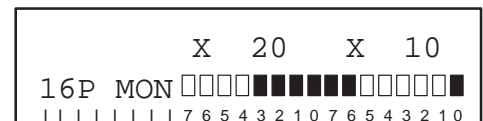

Forcing Discrete I/O Points

You can also force I/O points from the status display by using the ON and OFF keys. You can display the points first, or you can force the points from a clear display.

It is important to note that the DL405 CPUs only retain the forced value for one scan if the output point is used in the logic program or if the input point used corresponds to module that is installed in the base. The following example shows how the forcing actually works.

Force I/O Points

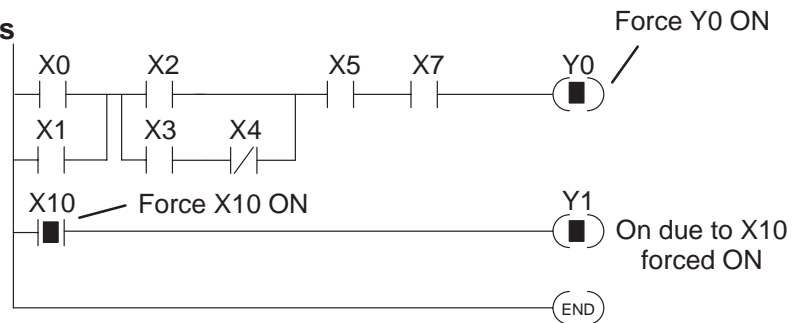

Next Scan

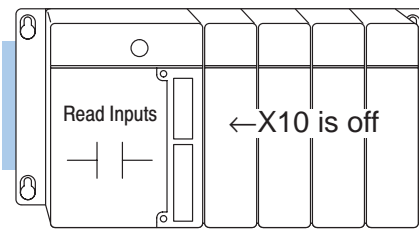

CPU reads the I/O status from the modules. Sees that X10 is off, overwrites the force command and turns off X10.

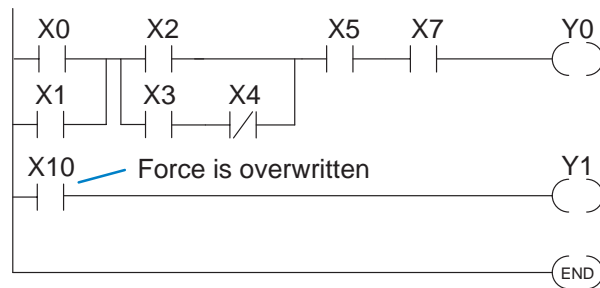

Logic is solved. X10, even though previously forced on, is turned off. Y0 and Y1 are turned off since conditions are not met.

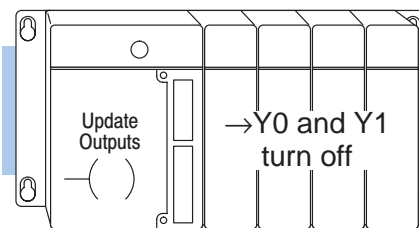

CPU updates the output status with the results obtained from the logic execution. Y0 and Y1 were turned off.

NOTE: If you use a CR as an input, you will not have the “one scan” problem.

The following example shows the keystrokes required to force an I/O point.

WARNING: Depending on your application, forcing I/O points may cause unpredictable machine operation that can result in a risk of personal injury or equipment damage.

Select the data type and range to monitor

Y(OUT) 0 BIT ST

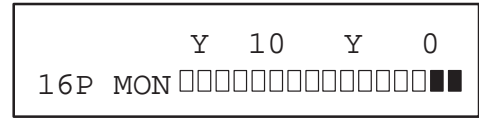

Select the point and ON or OFF

Y(OUT) 0 SHFT OFF

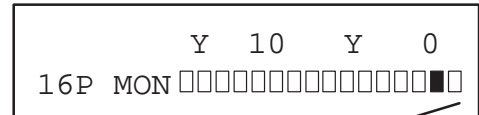

Y0 is now off

Or, from a clear display. . .

Y(OUT) 0 SHFT ON

(Note that you cannot see the I/O status with this method.)



Monitoring V-Memory Locations

You can also use the Handheld to monitor and change V memory locations. This is an especially useful feature, since almost all DL405 system data is mapped into V memory. The following steps show you how to monitor V-memory locations.

Select the location to monitor

V 2 5 0 0 WD ST

	V 2501	V 2500
V MON	0000	0256

Value is displayed

Use the PREV and NXT keys to scroll through additional points

NXT

	V 2502	V 2501
V MON	0000	0000

Changing V-Memory Values

Select the location to monitor

V 2 5 0 1 WD ST

	V 2502	V 2501
V MON	0000	0000

Use the K(CON) key to load a value

K(CON) 4 3 2 ENT

	V 2502	V 2501
V MON	0000	0432

Monitoring Timer/Counter Values

Timer and Counter current values are mapped into V-memory locations. Use the procedure for displaying V memory to examine these current values. (Appendix A provides a complete listing of the memory map for the DL405 systems.)

Monitoring the CPU Scan Time

The DL405 CPUs have a “watchdog” timer that is used to monitor the scan time. The default value set from the factory is 200 ms. If the scan time exceeds the watchdog time limit, the CPU automatically leaves RUN mode and enters PGM mode. The Handheld displays the following message E003 S/W TIMEOUT when the scan overrun occurs.

You can use AUX 53 to view the minimum, maximum, and current scan time. Use AUX 55 to increase or decrease the watchdog timer value.

Use AUX 53 to view the scan time

AUX 5 3 ← ←

SCAN	MAX	MIN
0004	0006	0002

The CPU must be in PGM or TEST-PGM mode before you can change the watchdog timer value.

Use AUX 55 to change the watchdog value

AUX 5 5 ← ←

```
AUX 55 SET WATCHDOG TMR
0200 MSEC
```

current setting

Enter the new time value (in milliseconds)

1 0 0 ←

```
AUX 55 SET WATCHDOG TMR
OK
```

Test Modes

TEST-PGM and TEST-RUN

Test Mode allows the CPU to start in TEST-PGM mode, enter TEST-RUN mode, run a fixed number of scans, and then return to TEST-PGM mode. You can select from 1 to 65,535 scans.

Use the following keystrokes to enter the Test Modes. (The actual mode entered when you first select Test Mode depends on the mode of operation at the time you make the request. If the CPU is in RUN mode, then TEST-RUN is entered. If the mode is PGM, then TEST-PGM is entered.)

Use AUX 12 to enter Test Mode

AUX 1 2 ENT ENT

MODE = TEST-PGM

While in TEST-PGM mode you can specify the number of scans by entering. . .

CLR 1 SHFT TEST

(CPU runs scans and returns to TEST-PGM)

NO. OF SCANS?

To switch from TEST-RUN to TEST-PGM mode . . .

CLR 2 SHFT TEST

ENT
 (to confirm the return to TEST-PGM)

STOP SCAN?

To switch from TEST-PGM to TEST-RUN mode . . .

CLR 3 SHFT TEST

ENT
 (to confirm the entry of TEST-RUN)

START SCAN?

You gain some advantages by using Test Mode.

- The status displays are more detailed.
- You can enable the CPU to hold output states.

Test Mode Displays For some instructions, the TEST-RUN mode display is more detailed than the status displays shown in RUN mode. The following diagram shows an example of a Timer instruction display during TEST-RUN mode.

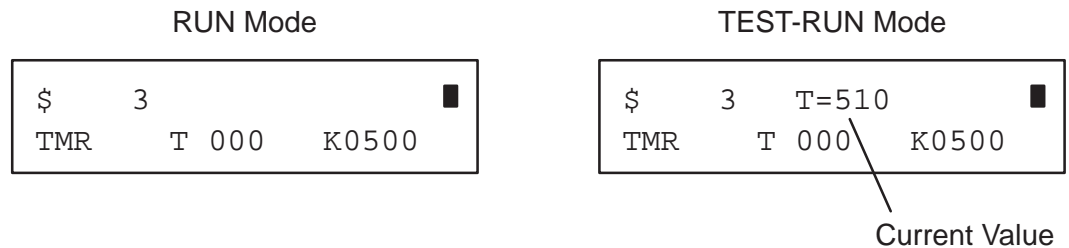

Holding Output States

In normal RUN mode, the outputs are turned off when you return to PGM mode. In TEST-RUN mode you can set each individual output to either turn off, or, hold its last output state on the transition to TEST-PGM mode. The ability to hold the output states is especially useful, since it allows you to maintain key system I/O points for examination. The following diagram shows the differences between RUN and TEST-RUN modes.

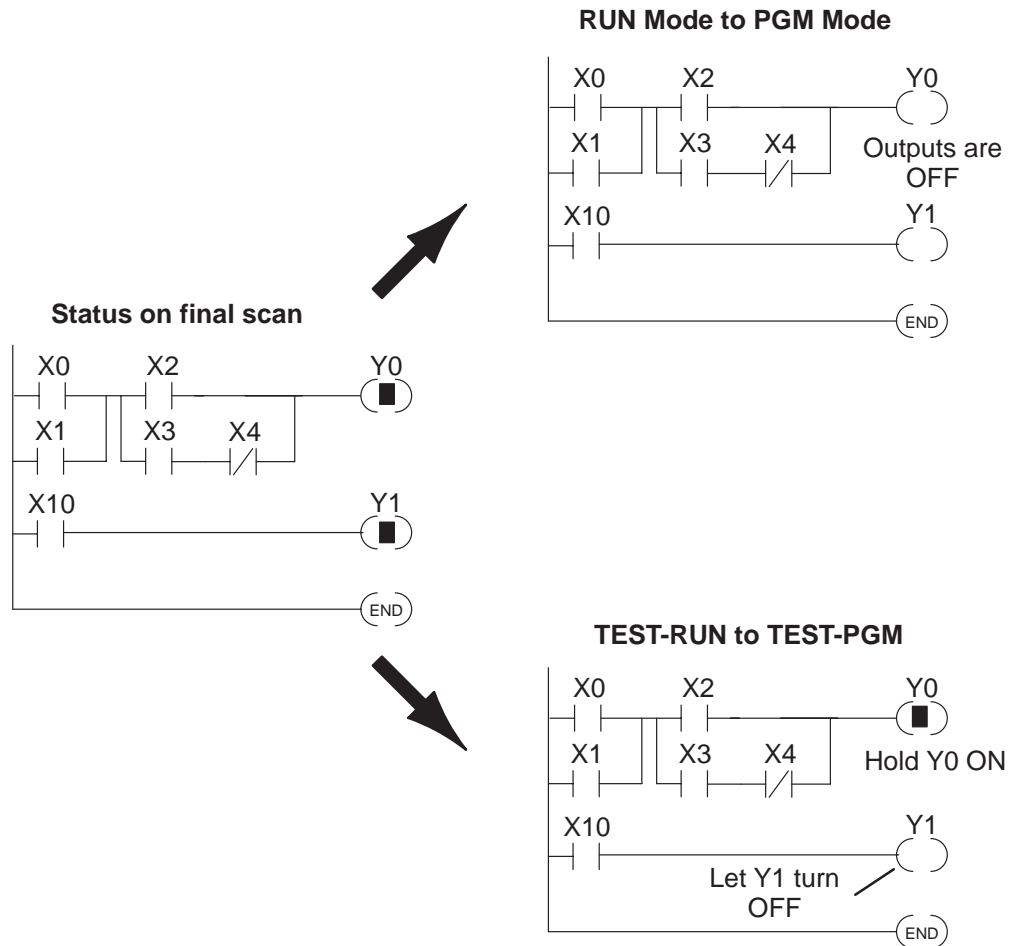

You can use AUX 58 to configure each individual output. The following keystrokes show an example.

Use AUX 58 to configure the output state

AUX 5 8 ENT ENT

```
AUX 58 TEST OPERATIONS
Y0000 OFF
```

To hold the last state on mode transition . . .

SHFT ON

```
AUX 58 TEST OPERATIONS
Y0000 ON
```

To turn the output off on mode transition . . .

SHFT OFF

```
AUX 58 TEST OPERATIONS
Y0000 OFF
```

To select an output for configuration

CLR Y(OUT) 5 0 NXT

(You can also use PREV and NXT to sequentially step through the outputs.)

```
AUX 58 TEST OPERATIONS
Y0050 OFF
```

I/O Diagnostics

Diagnostic Indicators

The DL405 system provides many diagnostic features that normally are not found on much larger, more expensive, PLCs. There are three primary tools that help identify I/O errors.

- CPU status LEDs
- I/O module status LEDs
- AUX 42, I/O Diagnostics

The following diagram shows how these three things can be used to locate the source of the error very quickly.

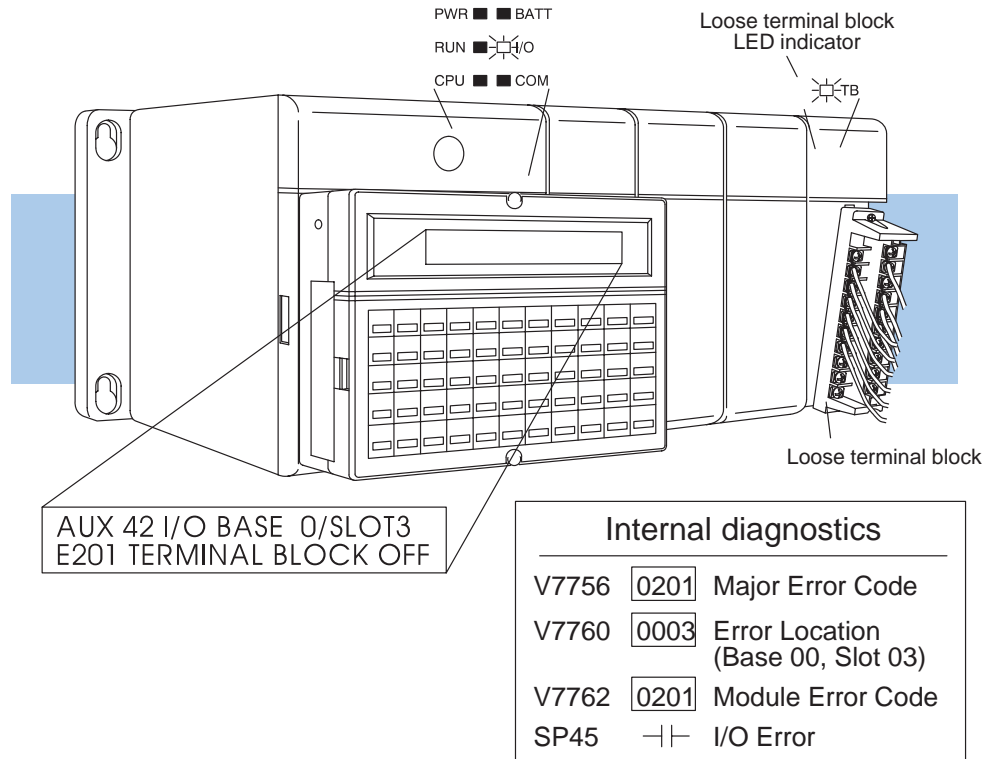

Using AUX 42

When an I/O error occurs, the Handheld automatically displays a message that indicates an I/O error. This example display shows the error message.

```
E2** DIAG ERROR AUX 42
```

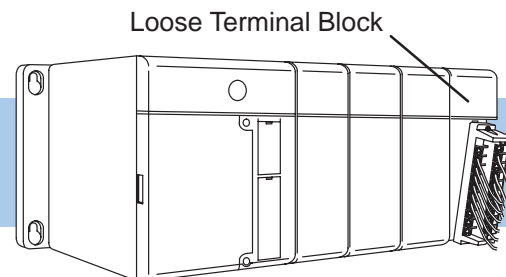

The display indicates that you should use AUX 42 to pinpoint the location of the error.

Use AUX 42

```
AUX  4  2  ENT  ENT
[ ] [ ] [ ] [ ] [ ]
```

```
AUX 42 I/O BASE0/SLOT1
E201 TERMINAL BLOCK OFF
```

The error codes listing, provided later in this chapter, shows all of the possible I/O error messages.

Custom Messages

The standard diagnostic tools help you identify system problems quickly, but what if you need messages that tell the machine operator to perform a certain task? You can purchase an operator interface, or you can use the Handheld Programmer (which you already have) as a low-cost message display. The Handheld Programmer is not a high performance display (due to the amount of time it may take to display the message). If you need a fast display time, you should probably consider another type of message display.

The following diagram shows how the message display capability works.

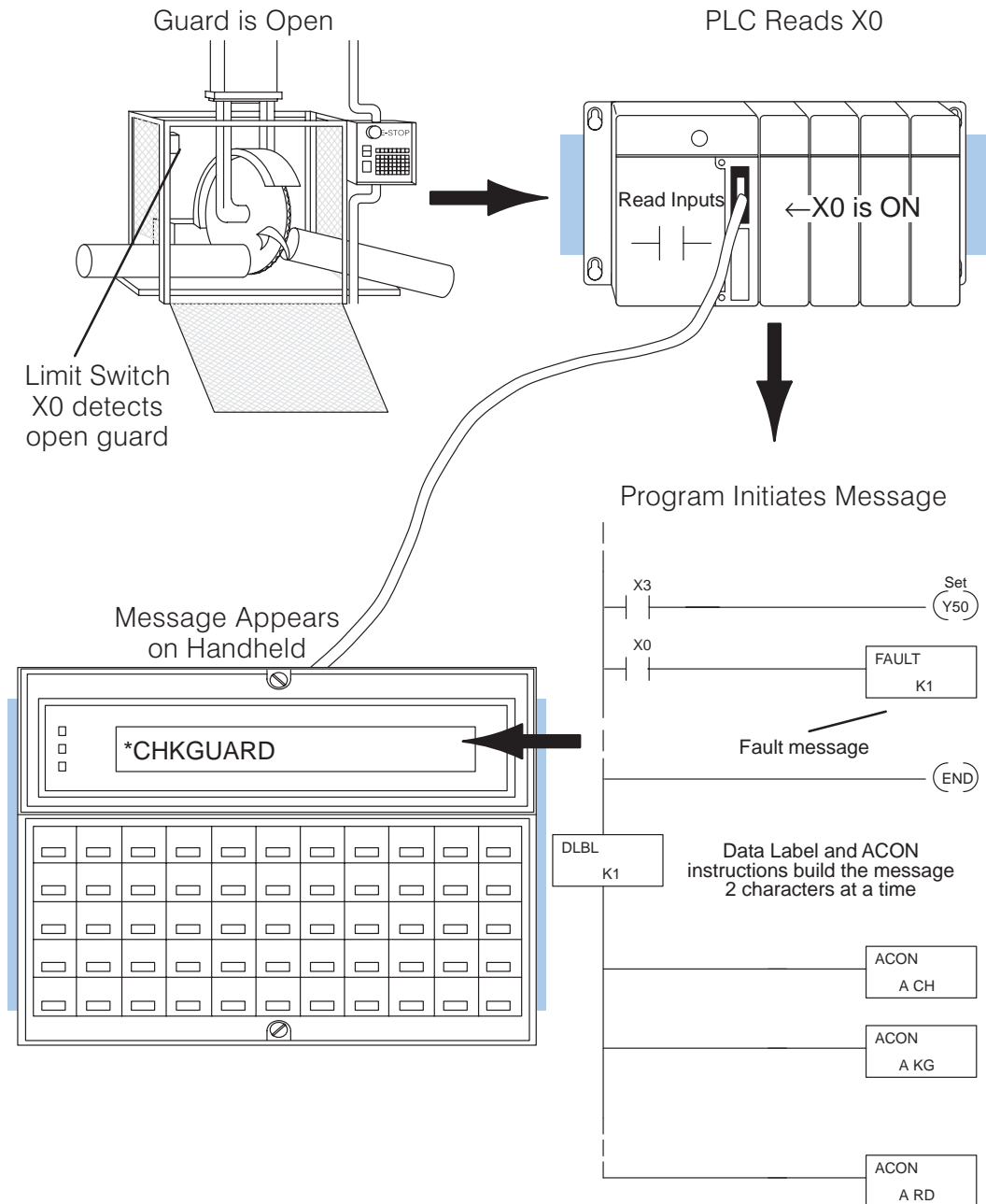

If you have a DL440 CPU, you can easily build and display up to 64 custom messages. The messages can be up to 23 characters in length and contain both text and numeric values. The messages are part of the RLL program and are displayed automatically on the Handheld Programmer during RUN mode.

The DL440 CPU has several instructions that are used to build operator messages. Detailed explanations of the following instructions are included in the DL405 User Manual.

- FAULT — the Fault instruction is an output box instruction that lets the program know which message to display.
- DLBL — the Data Label instruction is included *after* the END statement and notes the beginning of a message.
- ACON — the ASCII Constant instruction is used as an output box for the ASCII portion of the message. (You can also display the contents of a V-memory location instead of ASCII text.)
- NCON — the Numeric Constant instruction is used as an output box for any numeric constant portion of the message.
- MOVMC — the Move Data Label to V-memory Area instruction is used to embed variables, such as timer or counter values, into a text message.

The next two pages show an example and the keystrokes required to enter a very simple text message with the Handheld.

NOTE: It is *much* easier to enter text message programs with **DirectSOFT** than it is with the Handheld Programmer. This is because you can only enter two ASCII characters per ACON instruction with the Handheld. This is not the case with **DirectSOFT**, which allows you to enter up to 8 characters per ACON instruction. **DirectSOFT** also supports other characters not available on the handheld keypad.

The following program will display the message CHKGUARD on the Handheld when C0 is on.

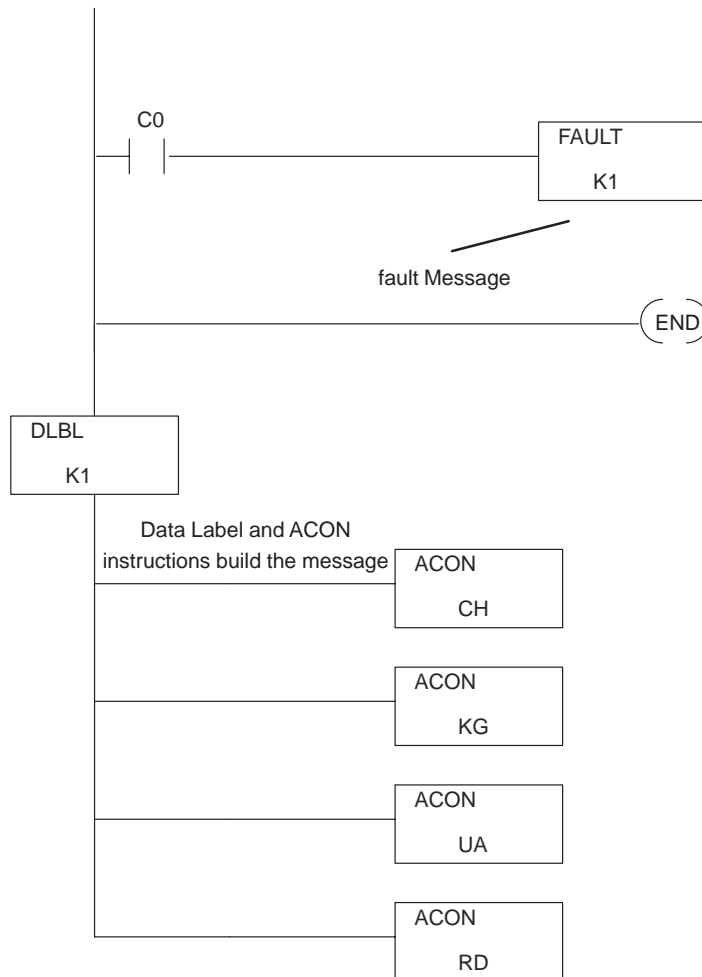

NOTE: The DL430 CPU also allows you to use the Fault instruction, but you cannot create text messages because the DLBL, ACON, NCON, and MOVMC instructions do not exist. If you're using a DL430, you can replace the constant (K) value used with the Fault instruction with a V-memory address. Then, the Handheld will display whatever code is stored in that V-memory address. For example, if you used a Fault message with a reference to V2000 and V2000 held the constant 1234, then the Handheld would display that constant value. This is still useful because you can easily build a chart that would show the operator what the various codes mean.

If you have a DL440 CPU handy, enter the program on the next page to see how it actually works. Once you've entered the program, put the CPU in RUN mode and force C0 on to display the message.

Enter the first contact

STR X 0 ENT

Starting at Address 0

\$ 0
STR X0

Enter the Fault instruction

SHFT F A U L T K(CON)
 1 ENT

\$ 1
FAULT K1

Enter the END statement

END ENT

\$ 3
END

Enter the DLBL instruction

SHFT D L B L K(CON) 1
 ENT

\$ 4
DLBL K1

Enter the ACON instruction and the first two letters

SHFT A C O N ASC
SHFT C H ENT

\$ 6
ACON A CH

Enter the next two characters

SHFT A C O N ASC
SHFT K G ENT

\$ 7
ACON A KG

Enter the next two characters

SHFT A C O N ASC
SHFT U A ENT

\$ 8
ACON A UA

Enter the last two characters

SHFT A C O N ASC
SHFT R D ENT

\$ 9
ACON A RD

Checking the Error Message Tables

Two Types of Tables

The DL440 CPU will automatically log any system error codes and custom messages created with the FAULT instructions. The CPU logs the error code, the date, and the time the error occurred. There are two separate tables that store this information.

- Error Code Table – the system logs up to 32 errors in the table. When an error occurs, the errors already on the table are pushed down and the most recent error is loaded into the top slot. If the table is full when an error occurs, the oldest error is pushed out (erased) from the table.
- Message Table – the system logs up to 16 messages in this table. When a message is triggered, the messages already stored in the table are pushed down and the most recent message is loaded into the top slot. If the table is full when an error occurs, the oldest message is pushed out (erased) of the table.

The following diagram shows an example of an error table for messages.

Date	Time	Message
1993-05-26	08:41:51:11	*Conveyor-2 stopped
1993-04-30	17:01:11:56	* Conveyor-1 stopped
1993-04-30	17:01:11:12	* Limit SW1 failed
1993-04-28	03:25:14:31	* Saw Jam Detect

Viewing the Error Table

You can use AUX Function 5C to show the error codes.

Use AUX 5C to view the tables

AUX 5 SHFT C ENT

```
AUX 5C SHOW ERR/MSG
ERR OR MSG
```

Press ENT to select Error Messages

ENT

(The most recent error is displayed. You can also use PREV and NXT to sequentially step through the errors.)

```
E151 BAD COMMAND
04/22/93 17:30:00
```

Viewing the Message Table

You use the same AUX function, 5C, to show the messages.

Use AUX 5C to view the tables

AUX 5 SHFT C ENT

```
AUX 5C SHOW ERR/MSG
ERR OR MSG
```

Use the arrow key to select MSG

SHFT ENT

(The most recent message is displayed. You can also use PREV and NXT to sequentially step through the messages.)

```
PUMP 3 FAILED
04/22/93 17:30:00
```

Error Codes

The following table lists the error codes that may appear on the Handheld.

DL405 Error Code	Description
E001 CPU Fatal Error	You may possibly clear the error by power cycling the CPU. If the error returns replace the CPU.
E003 Software Time-out	If the program scan time exceeds the time allotted to the watchdog timer, this error will occur. SP51 will be on and the error code will be stored in V7755. To correct this problem add RSTWT instructions in FOR NEXT loops and subroutines or using AUX 55 extend the time allotted to the watchdog timer.
E004 Invalid Instruction (DL440 only)	The application program has changed for some reason. SP44 will be on and the error code will be stored in V7755. This problem may possibly be due to electrical noise. Use AUX21 to check the program syntax and correct where necessary or clear the memory and re-download the program. Correct any grounding problems. If the error returns replace the CPU.
E041 CPU Battery Low	The CPU battery is low and should be replaced. SP43 will be on and the error code will be stored in V7757.
E043 Memory Cartridge Battery low (DL440 only)	The Memory Cartridge battery is low and should be replaced. SP43 will be on and the error code will be stored in V7757.
E099 Program Memory Exceeded	If the compiled program length exceeds the amount of available CPU RAM this error will occur. SP52 will be on and the error code will be stored in V7755. Reduce the size of the application program.
E101 CPU MC Missing (DL440 only)	The CPU Memory Cartridge has failed or is missing. SP44 will be on and the error code will be stored in V7755. Install or replace the Memory Cartridge.
E104 Write Failed (DL440 only)	A write to the CPU Memory Cartridge was not successful. The Memory Cartridge may be write protected. Disassemble and check the jumper. If the error still occurs replace the Memory Cartridge.
E151 Invalid Command	A parity error has occurred in the application program. SP44 will be on and the error code will be stored in V7755. This problem may possibly be due to electrical noise. Clear the memory and re-download the program. Correct any grounding problems. If the error returns replace the Memory Cartridge or CPU.
E155 RAM Failure	A checksum error has occurred in the system RAM. SP44 will be on and the error code will be stored in V7755. This problem may possibly be due to a low battery, electrical noise or a CPU RAM failure. Clear the memory and re-download the program. Correct any grounding problems. If the error returns replace the CPU.
E2** I/O Module Failure	An I/O module has failed. Run AUX42 to determine the actual error.
E201 Terminal Block Missing	A terminal block is loose or missing from an I/O module. SP45 will be on and the error code will be stored in V7756.

DL405 Error Code	Description
E202 Missing I/O Module	An I/O module has failed to communicate with the CPU or is missing from the base. SP45 will be on and the error code will be stored in V7756. Run AUX42 to determine the slot and base location of the module reporting the error.
E203 Blown Fuse	A fuse has blown in an I/O module. SP45 will be on and the error code will be stored in V775. Run AUX42 to determine the slot and base location of the module reporting the error.
E206 User 24V Power Supply Failure.	The 24VDC power supply being used to power output modules has failed. SP45 will be on and the error code will be stored in V7756. Run AUX42 to determine the slot and base location of the module reporting the error.
E250 Communication Failure In The I/O Chain	A failure has occurred in the local I/O system. The problem could be in the base, expansion cable or I/O Expansion Unit power supply. Check all cabling between bases and replace faulty hardware if necessary. SP45 will be on and the error code will be stored in V7755. Run AUX42 to determine the base location reporting the error.
E252 New I/O CFG	This error occurs when the auto configuration check is turned on in the CPU and the actual I/O configuration has changed either by moving modules in a base or changing types of modules in a base. You can return the modules to the original position/types or run AUX45 to accept the new configuration. SP47 will be on and the error code will be stored in V7755.
E261 I/O Address Conflict (DL440 only)	Overlapping addresses have been assigned while manually configuring the I/O. Correct the address assignments using AUX46. SP45 will be on and the error code will be stored in V7755.
E262 I/O Out Of Range	An out of range I/O address has been encountered in the application program. Correct the invalid address in the program. SP45 will be on and the error code will be stored in V7755.
E263 Configured I/O Address Out Of Range (DL440 only)	Out of range addresses have been assigned while manually configuring the I/O. Correct the address assignments using AUX46. SP45 will be on and the error code will be stored in V7755.
E264 Duplicate I/O Reference (DL440 only)	Duplicate addresses have been assigned while manually configuring the I/O. Correct the address assignments using AUX46.
E311 HPP Comm Error 1	A request from the handheld programmer could not be processed by the CPU. Clear the error and retry the request. If the error continues replace the CPU. SP46 will be on and the error code will be stored in V7756.

DL405 Error Code	Description
E312 HPP Comm Error 2	A data error was encountered during communications with the CPU. Clear the error and retry the request. If the error continues check the cabling between the two devices, replace the handheld programmer, then if necessary replace the CPU. SP46 will be on and the error code will be stored in V7756.
E313 HPP Comm Error 3	An address error was encountered during communications with the CPU. Clear the error and retry the request. If the error continues check the cabling between the two devices, replace the handheld programmer, then if necessary replace the CPU. SP46 will be on and the error code will be stored in V7756.
E316 HPP Comm Error 6	A mode error was encountered during communications with the CPU. Clear the error and retry the request. If the error continues replace the handheld programmer, then if necessary replace the CPU. SP46 will be on and the error code will be stored in V7756.
E320 HPP Comm Time-out	The CPU did not respond to the handheld programmer communication request. Check to insure cabling is correct and not defective. Power cycle the system if the error continues replace the CPU first and then the handheld programmer if necessary.
E321 Comm Error	A data error was encountered during communication with the CPU. Check to insure cabling is correct and not defective. Power cycle the system and if the error continues replace the CPU first and then the handheld programmer if necessary.
E360 HPP Peripheral Port Time-out	The device connected to the peripheral port did not respond to the handheld programmer communication request. Check to insure cabling is correct and not defective. The peripheral device or handheld programmer could be defective.
E4** No Program	A syntax error exist in the application program. The most common is a missing END statement. Run AUX21 to determine which one of the E4** series of errors is being flagged. SP52 will be on and the error code will be stored in V7755.
E401 Missing END Statement	All application programs must terminate with an END statement. Enter the END statement in appropriate location in your program. SP52 will be on and the error code will be stored in V7755.
E402 Missing LBL (DL440 only)	A GOTO, GTS, MOV MC or LD LBL instruction was used without the appropriate label. Refer to the DL405 User Manual for details on these instructions. SP52 will be on and the error code will be stored in V7755.
E403 Missing RET (DL440 only)	A subroutine in the program does not end with the RET instruction. SP52 will be on and the error code will be stored in V7755.
E404 Missing FOR (DL440 only)	A NEXT instruction does not have the corresponding FOR instruction. SP52 will be on and the error code will be stored in V7755.

DL405 Error Code	Description
E405 Missing NEXT (DL440 only)	A FOR instruction does not have the corresponding NEXT instruction. SP52 will be on and the error code will be stored in V7755.
E406 Missing IRT	An interrupt routine in the program does not end with the IRT instruction. SP52 will be on and the error code will be stored in V7755.
E412 SBR/LBL>64 (DL440 only)	There is greater than 64 SBR, LBL or DLBL instructions in the program. This error is also returned if there is greater than 128 GTS or GOTO instructions used in the program. SP52 will be on and the error code will be stored in V7755.
E413 FOR/NEXT>64 (DL440 only)	There is greater than 64 FOR/NEXT loops in the application program. SP52 will be on and the error code will be stored in V7755.
E421 Duplicate Stage Reference	Two or more SG or ISG labels exist in the application program with the same number. A unique number must be allowed for each Stage and Initial Stage. SP52 will be on and the error code will be stored in V7755.
E422 Duplicate SBR/LBL Reference (DL440 only)	Two or more SBR or LBL instructions exist in the application program with the same number. A unique number must be allowed for each Subroutine and Label. SP52 will be on and the error code will be stored in V7755.
E423 Nested Loops (DL440 only)	Nested loops (programming one FOR/NEXT loop inside of another) is not allowed in the DL440 series. SP52 will be on and the error code will be stored in V7755.
E431 Invalid ISG/SG Address	An ISG or SG must not be programmed after the end statement such as in a subroutine. SP52 will be on and the error code will be stored in V7755.
E432 Invalid Jump (GOTO) Address (DL440 only)	A LBL that corresponds to a GOTO instruction must not be programmed after the end statement such as in a subroutine. SP52 will be on and the error code will be stored in V7755.
E433 Invalid SBR Address (DL440 only)	A SBR must be programmed after the end statement, not in the main body of the program or in an interrupt routine. SP52 will be on and the error code will be stored in V7755.
E434 Invalid RTC Address (DL440 only)	A RTC must be programmed after the end statement, not in the main body of the program or in an interrupt routine. SP52 will be on and the error code will be stored in V7755.
E440 Invalid RT Address (DL440 only)	A RT must be programmed after the end statement, not in the main body of the program or in an interrupt routine. SP52 will be on and the error code will be stored in V7755.
E436 Invalid INT Address	An INT must be programmed after the end statement, not in the main body of the program. SP52 will be on and the error code will be stored in V7755.
E437 Invalid IRTC Address	An IRTC must be programmed after the end statement, not in the main body of the program. SP52 will be on and the error code will be stored in V7755.

DL405 Error Code	Description
E438 Invalid IRT Address	An IRT must be programmed after the end statement, not in the main body of the program. SP52 will be on and the error code will be stored in V7755.
E440 Invalid Data Address (DL440 only)	Either the DLBL instruction has been programmed in the main program area (not after the END statement), or the DLBL instruction is on a rung containing input contact(s).
E441 ACON/NCON (DL440 only)	An ACON or NCON must be programmed after the end statement, not in the main body of the program. SP52 will be on and the error code will be stored in V7755.
E451 Bad MLS/MLR	MLS instructions must be numbered in ascending order from top to bottom.
E452 X AS Coil	An X data type is being used as a coil output.
E453 Missing T/C	A timer or counter contact is being used where the associated timer or counter does not exist.
E454 Bad TMRA	One of the contacts is missing from a TMRA instruction.
E455 Bad CNT	One of the contacts is missing from a CNT or UDC instruction.
E456 Bad SR	One of the contacts is missing from the SR instruction.
E461 Stack Overflow	More than nine levels of logic have been stored on the stack. Check the use of OR STR and AND STR instructions.
E462 Stack Underflow	An unmatched number of logic levels have been stored on the stack. Insure the number of AND STR and OR STR instructions match the number of STR instructions.
E463 Logic Error	A STR instruction was not used to begin a rung of ladder logic.
E464 Missing CKT	A rung of ladder logic is not terminated properly.
E471 Duplicate Coil Reference	Two or more OUT instructions reference the same I/O point.
E472 Duplicate TMR Reference	Two or more TMR instructions reference the same number.
E473 Duplicate CNT Reference	Two or more CNT instructions reference the same number.
E480 Invalid CV Address (DL440 only)	The CV instruction is used in a subroutine or program interrupt routine. The CV instruction may only be used in the main program area (before the END statement).

DL405 Error Code	Description
E481 Conflicting Instructions (DL440 only)	An instruction exists between convergence stages.
E482 Max. CV Instructions Exceeded (DL440 only)	Number of CV instructions exceeds 17.
E483 Invalid CV Jump Address (DL440 only)	CV JMP has been used in a subroutine or a program interrupt routine.
E484 Missing CV Instruction (DL440 only)	CV JMP is not preceded by the CV instruction. A CV JMP must immediately follow the CV instruction.
E485 Missing required instruction (DL440 only)	A CV JMP instruction is not placed between the CV and the [SG, ISG, ST BLK, END BLK, END] instruction.
E486 Invalid CALL BLK address (DL440 only)	CALL BLK is used in a subroutine or a program interrupt routine. The CALL BLK instruction may only be used in the main program area (before the END statement).
E487 Missing ST BLK Instruction (DL440 only)	The CALL BLK instruction is not followed by a ST BLK instruction.
E488 Invalid ST BLK Address (DL440 only)	The ST BLK instruction is used in a subroutine or a program interrupt. Another ST BLK instruction is used between the CALL BLK and the END BLK instructions.
E489 Duplicated CR Reference (DL440 only)	The control relay used for the ST BLK instruction is being used as an output elsewhere.
E490 Missing SG instruction (DL440 only)	The ST BLK instruction is not immediately followed by the SG instruction.
E491 Invalid ISG Instruction Address (DL440 only)	There is an ISG instruction between the ST BLK and END BLK instructions.

DL405 Error Code	Description
E492 Invalid END BLK Address (DL440 only)	The END BLK instruction is used in a subroutine or a program interrupt routine. The END BLK instruction is not followed by a ST BLK instruction.
E493 Missing Required Instruction (DL440 only)	A [CV, SG, ISG, ST BLK, END] instruction must immediately follow the END BLK instruction.
E494 Missing END BLK Instruction (DL440 only)	The ST BLK instruction is not followed by a END BLK instruction.
E501 Bad Entry	An invalid keystroke or series of keystrokes was entered into the handheld programmer.
E502 Bad Address	An invalid or out of range address was entered into the handheld programmer.
E503 Bad Command	An invalid instruction was entered into the handheld programmer.
E504 Bad Ref/VAL	An invalid value or reference number was entered with an instruction.
E505 Invalid Instruction	An invalid instruction was entered into the handheld programmer.
E506 Invalid Operation	An invalid operation was attempted by the handheld programmer.
E520 Bad Op-RUN	An operation which is invalid in the RUN mode was attempted by the handheld programmer.
E521 Bad OP-TRUN	An operation which is invalid in the TEST RUN mode was attempted by the handheld programmer.
E523 Bad OP-TPGM	An operation which is invalid in the TEST PROGRAM mode was attempted by the handheld programmer.
E524 Bad OP-PGM	An operation which is invalid in the PROGRAM mode was attempted by the handheld programmer.
E525 Keyswitch	An operation was attempted by the handheld programmer while the CPU keyswitch was in a position other than the TERM position.
E526 Off Line	The handheld programmer is in the OFFLINE mode. To change to the ONLINE mode use AUX64.
E540 CPU Locked (DL440 only)	The CPU has been password locked. To unlock the CPU use AUX82 with the password.
E541 Wrong Password (DL440 only)	The password used to unlock the CPU with AUX82 was incorrect.

DL405 Error Code	Description
E542 Password Reset (DL440 only)	The CPU powered up with an invalid password and reset the password to 00000000. A password may be re-entered using AUX81.
E601 Memory Full	Attempted to enter an instruction which required more memory than is available in the CPU.
E602 Instruction Missing	A search function was performed and the instruction was not found.
E603 Data Missing (DL440 only)	A search function was performed and the data was not found.
E604 Reference Missing	A search function was performed and the reference was not found.
E610 Bad I/O Type	The application program has referenced an I/O module as the incorrect type of module.
E620 Out Of Memory	An attempt to transfer more data between the CPU and handheld programmer than the receiving device can hold.
E621 MC Not Blank	An attempt to write to a non-blank Memory Cartridge was made. Erase the cartridge and then retry the write.
E622 No HPP MC	A data transfer was attempted with no Memory Cartridge or possibly a faulty Memory Cartridge in the handheld programmer.
E623 System MC	A function was requested with a Memory Cartridge which contains system information only.
E624 V-memory only	A function was requested with a Memory Cartridge which contains V-memory data only.
E625 Program only	A function was requested with a Memory Cartridge which contains program data only.
E626 PROM MC	An attempt to transfer data from a tape to a UVROM Memory Cartridge. This transfer must be made using a CMOS RAM Cartridge.
E627 Bad Write	An attempt to write to a write protected or faulty Memory Cartridge was made. Check the write protect jumper inside the cartridge then replace if necessary.
E640 Compare error	A compare between the Memory cartridge and the source data was found to be in error. Erase the Memory Cartridge and retry the operation, replace the Memory Cartridge if necessary.
E641 Volume Level	The volume level of the cassette player is not set properly. Adjust the volume and retry the operation.
E642 Checksum Error	An error was detected while data was being transferred to the handheld programmer's Memory Cartridge. Check cabling and retry the operation.
E650 HPP System Error	A system error has occurred in the handheld programmer. Power cycle the handheld programmer. If the error returns replace the handheld programmer.
E651 HPP ROM Error	A ROM error has occurred in the handheld programmer. Power cycle the handheld programmer. If the error returns replace the handheld programmer.

DL405 Error Code	Description
E652 HPP RAM Error	A RAM error has occurred in the handheld programmer. Power cycle the handheld programmer. If the error returns replace the handheld programmer.
E653 MC Battery Low	The battery in the CMOS RAM cartridge is low and should be replaced.