



# Errata Sheet

This Errata Sheet contains corrections or changes made after the publication of this manual.

**Product Family:** DL305  
**Manual Number:** D3-USER-M  
**Revision and Date:** 1st Edition, Rev. D; January 2010

**Date:** August 2018

## Changes to Chapter 2. Installation and Safety Guidelines

Page 2-12. Base Wiring

On newer 110-240 VAC bases, the terminal strip has been re-designed and does not have different terminals for 110VAC and 240VAC connections. If you have one of these re-designed bases the terminal strip will look like this:

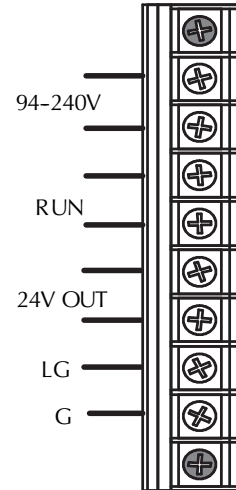

## Changes to Chapter 3. DL330/DL330P/DL340 CPU Specifications

Page 3-3. CPU Specifications

DL340 CPUs DO NOT support overrides. In row 3, Supports Overrides, change the “Yes” in the DL340 column to “No”.

Page 3-9. DL330/DL330P CPU Setup; Installing the UV PROM Option in the DL330/DL330P CPU

The drawing showing the jumpers is missing the silkscreen jumper lines and arrows for jumpers 1, 2 and 3. Refer to this drawing.

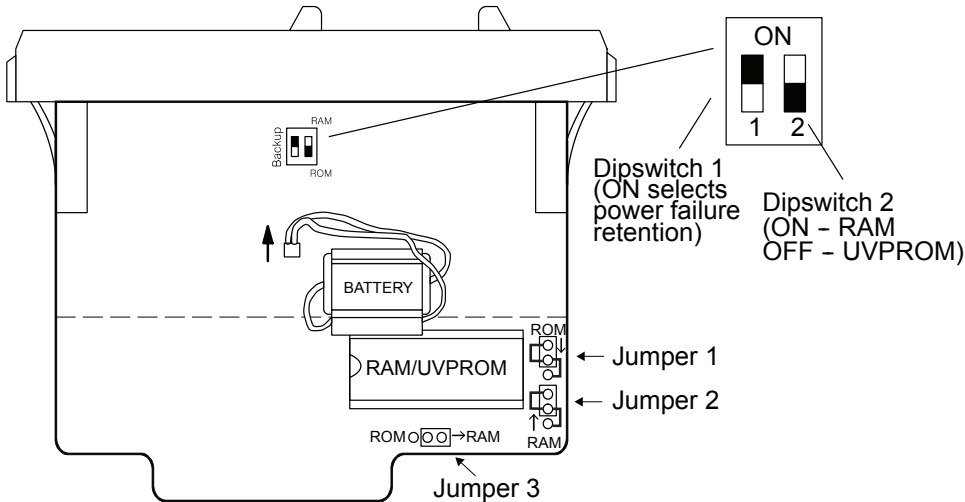





# Errata Sheet

This Errata Sheet contains corrections or changes made after the publication of this manual.

## Changes to Chapter 11. Instruction Set; Timer, Counter, and Shift Register Instructions

Page 11-22. Timer (TMR) DL330/DL340 Only

Page 11-23. Counter (CNT) DL330/DL340 Only

Add this NOTE to both of these pages:

NOTE: The counters and timers both time in Decimal and not in BCD. Presets for both are also interpreted as decimal data and not as BCD.

## Changes to Chapter 13. Maintenance and Troubleshooting

Page 13-13. Add the following to the end of this chapter (right after END Instruction Placement):

### Reset the PLC to Factory Defaults

**NOTE:** Resetting to factory defaults will not clear any password stored in the PLC.

Resetting a DirectLogic PLC to Factory Defaults is a two-step process. Be sure to have a verified backup of your program using “Save Project to Disk” from the File menu before performing this procedure. Please be aware that the program as well as any settings will be erased and not all settings are stored in the project. In particular you will need to write down any settings for Secondary Communications Ports and manually set the ports up after resetting the PLC to factory defaults.

Step 1 – While connected to the PLC with DirectSoft, go to the PLC menu and select; “Clear PLC Memory”. Check the “ALL” box at the bottom of the list and press “OK”.

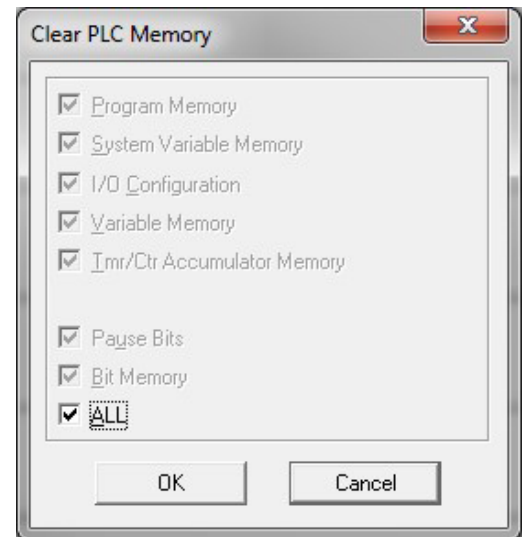

Step 2 – While connected with DirectSoft, go the PLC menu and then to the “Setup” submenu and select “Initialize Scratch Pad”. Press “Ok”.

**NOTE:** All configurable communications ports will be reset to factory default state. If you are connected via Port 2 or another configurable port, you may be disconnected when this operation is complete.

**NOTE:** Retentive ranges will be reset to the factory settings.

**NOTE:** Manually addressed IO will be reset to factory default settings.

The PLC has now been reset to factory defaults and you can proceed to program the PLC.

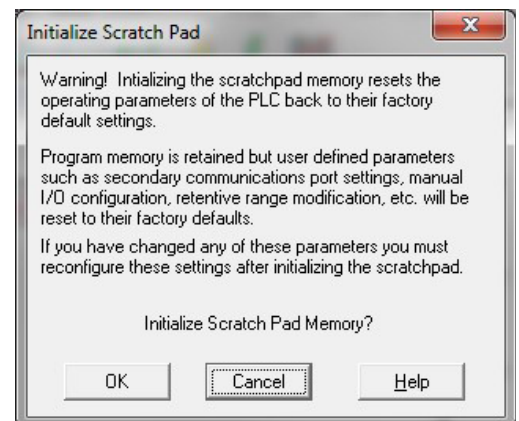

# Bases, Expansion Bases, and I/O Configuration

---

In This Chapter. . . .

- Understanding I/O Numbering and Module Placement Rules
  - Base Specifications and Wiring
  - Using Bases for Local or Expansion I/O Systems
  - Setting the Base Switches
  - Example I/O Configurations
  - I/O Configurations with a 5 Slot Local CPU Base
  - I/O Configurations with an 8 Slot Local CPU Base
  - I/O Configurations with a 10 Slot Local CPU Base
  - Calculating the Power Budget
-

## Understanding I/O Numbering and Module Placement Rules

Before you install any I/O modules or begin installing or using the bases, it is very helpful to understand how the DL305 I/O numbering and module placement restrictions can sometimes dictate how your system is put together.

### DL305 I/O Configuration History

The DL305 product family has had several enhancements over the years. Each time the product family has grown or has been enhanced, compatibility with the earlier products has been of the utmost concern. Some of these enhancements such as increasing the I/O count and supporting 16 point modules have impacted the numbering system. To help you understand our numbering scheme we have provided the following account of how the numbering system has been affected.

- When the 16 point I/O modules were introduced to the standard line of 8 point modules, the I/O numbering system was not modified to count in 16 consecutive units. This was done to maintain compatibility with the 8 point systems. This means each 16 point module uses two groups of eight consecutive numbers such as 000 through 007 and 100 through 107.
- When the I/O count was increased from the original 112 maximum to 176 maximum (for the DL330/DL330P CPU) and 184 maximum (for the DL340 CPU), most of the new I/O addresses were not set up to be consecutive with the the original 112 I/O. This means you will see a large jump in the I/O number ranges.

### Octal Numbering System

The DL305 I/O points are numbered in octal (base 8.) The octal numbering system does not include the numbers 8 and 9. The following table lists the first few octal numbers with the equivalent decimal numbers so you can see the numbering pattern.

<b>Octal Numbers</b>	0	1	2	3	4	5	6	7	10	11	12	13	14	15	16	17	20	21	22	23	24	...
<b>Decimal Numbers</b>	0	1	2	3	4	5	6	7	8	9	10	11	12	13	14	15	16	17	18	19	20	...

### Fixed I/O Numbering

The DL305 base I/O numbering is fixed, you cannot choose the I/O address of specific points since the system allocates the addresses for each slot. The I/O number ranges are 0–177 and 700–767. The I/O numbering for each slot in the base depends on two things:

1. The base configuration, which is determined by the size of the base and whether you are using an expansion base.
2. The number of I/O points per module and the location of the I/O modules in the base.

**I/O Numbering Guidelines**

I/O numbering begins with address “000” which is the slot adjacent to the CPU. Each module uses increments of eight I/O points. For 8 point modules the I/O addresses are made up of eight contiguous points for each module. For 16 point modules the I/O addresses are made up of two groups of eight contiguous points, the first group follows the same scheme as the 8 point module and the second group adds 100 to the values of the first group.

The examples below show the I/O numbering for a 5 slot local CPU base with 8 point I/O and a 5 slot local CPU base with 16 point I/O.

**5 Slot Base Using 8 Point I/O Modules**

**5 Slot Base Using 16 Point I/O Modules**

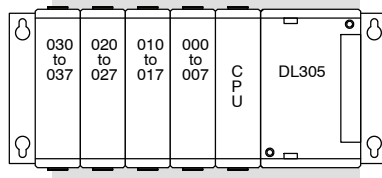

**Slot Number: 3-2-1-0**

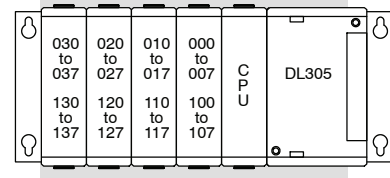

**Slot Number: 3-2-1-0**

**Number of I/O Points Required for Each Module**

DC Input Modules		DC Output Modules		Relay Output Modules		Analog Modules (cont.)	
D3-08ND2	8	D3-08TD1	8	D3-08TR	8	F3-04DA-1	16
D3-16ND2-1	16	D3-08TD2	8	F3-08TRS-1	8	F3-04DA-2	16
D3-16ND2-2	16	D3-16TD1-1	16	F3-08TRS-2	8	F3-04DAS	16
D3-16ND2F	16	D3-16TD1-2	16	D3-16TR	16	<b>ASCII BASIC Modules</b>	
F3-16ND3	16	D3-16TD2	16	<b>Analog Modules</b>		F3-AB128-R	16
<b>AC Input Modules</b>		<b>AC Output Modules</b>		D3-04AD	16	F3-AB128-T	16
D3-08NA-1	8	D3-04TAS	8*	F3-04ADS	16	F3-AB128	16
D3-08NA-2	8	F3-08TAS	8	F3-08AD	16	F3-AB64	16
D3-16NA	16	D3-08TA-1	8	F3-08TEMP	16	<b>Specialty Modules</b>	
<b>AC/DC Input Modules</b>		D3-08TA-2	8	F3-08THM-n	16	D3-08SIM	8
D3-08NE3	8	F3-16TA-1	16	F3-16AD	16	D3-HSC	16
D3-16NE3	16	D3-16TA-2	16	D3-02DA	16		

\* This is a 4-point module, but each slot is assigned a minimum of 8 I/O points.

### I/O Module Placement Rules

There are some limitations that determine where you can place certain types of modules. Some modules require certain locations and may limit the number or placement of other modules. We have tried to give clearly written explanations of the rules governing module placement, but we realize a picture can sometimes be worth a thousand words. If you have difficulty with some of our explanations, please look ahead to the illustrations in this chapter. They should clear up any gray areas in the explanation and you will probably find the configuration you intend to use in your installation.

In all of the configurations mentioned the number of slots from the CPU that are to be used can roll over into an expansion base if necessary. For example if a rule states a module must reside in one of the six slots adjacent to the CPU, and the system configuration is comprised of two 5 slot bases, slots 1 and 2 of the expansion base are valid locations.

The following table provides the general placement rules for the DL305 components.

Module	Restriction
CPU	The CPU must reside in the first slot of the local CPU base. The first slot is the closest slot to the power supply.
16 Point I/O Modules	There can be a maximum of eight 16 point modules installed in a system depending on the CPU type and I/O modules used. The 16 point modules must be in the first 8 slots adjacent to the CPU rolling over into an expansion base if necessary. If any of the eight slots adjacent to the CPU are not used for 16 point modules, they can be used for 8 point modules.
Analog Modules	Analog modules must reside in any valid 16 point I/O slot.
ASCII Basic Modules	ASCII Basic modules must reside in any valid 16 point I/O slot.
High Speed Counter	High Speed Counters may be used in one of the first 4 slots in the local CPU base.

### DL330/DL330P Rules for 16 Point Modules

The DL330 CPU can address up to seven 16 point modules as long as they reside in the seven slots adjacent to the CPU, however; there is one circumstance where the number of 16 point modules can be limited.

- Only six 16 point modules can be used if High Speed Counter modules are installed in the system. The 16 point modules must reside in the six slots adjacent to the CPU.



**NOTE:** The High Speed Counter module is considered to be a 16 point module.

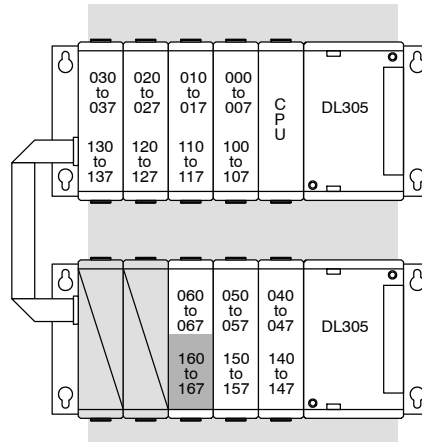

- Addresses 160 - 167 are not available as I/O if High Speed Counter modules are used in the system



**NOTE:** Addresses 160-167 are normally used as CRs, but they can also be used as I/O for 16 point modules. You cannot use the points as both CRs and I/O. Also, when you use these as I/O points, you still enter them as C160-C167 in *DirectSOFT*.



**DL340 Rules for 16 Point Modules**

The DL340 CPU can address up to eight 16 point modules as long as they reside in the eight slots adjacent to the CPU, however; there are circumstances where the number of 16 point modules can be limited.

1. Only seven 16 point modules can be used if a Thumbwheel Interface module is installed in the system. The 16 point modules must reside in the seven slots adjacent to the CPU.
2. Only seven 16 point modules can be used if High Speed Counter modules are installed in the system. The 16 point modules must reside in the six slots adjacent to the CPU, skipping one slot, and using the 8th slot from the CPU for the last of the 16 point modules.
3. Only six 16 point modules can be used if a High Speed Counter and a Thumbwheel Interface module are installed in the system. The 16 point modules must reside in the six slots adjacent to the CPU.



**NOTE:** Both High Speed Counter and Thumbwheel Interface modules are considered to be 16 point modules.

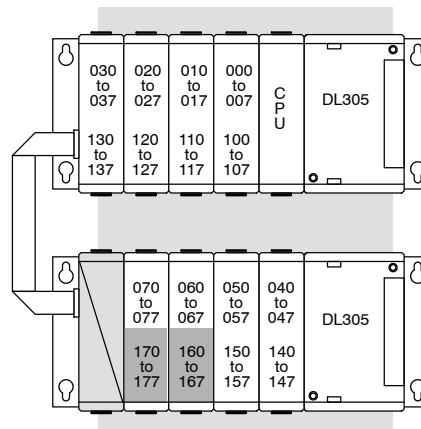

- Addresses 170 - 177 are not available as I/O if a Thumbwheel Interface module is used in the system
- Addresses 160 - 167 are not available as I/O if High Speed Counter modules are used in the system
- Addresses 160 - 167 and 170 - 177 are not available as I/O if both High Speed Counters and a Thumbwheel interface module are used in the system.



**NOTE:** Addresses 160 - 177 are normally used as CRs, but they can also be used as I/O points if you are using 16 point modules. Remember, if you use these locations as I/O points you cannot use them as CRs. Also, when you use these as I/O points, you still enter them as C160-C177 in *DirectSOFT*.

## Base Specifications and Wiring

### Three Sizes of Bases

There are three base sizes available to hold your I/O modules: 5, 8 and 10 slot. The 5 and 10 slot bases can be used as either a local CPU base or an expansion base. The 8 slot base can only be used as a local CPU base. The 5, 8, and 10 slot bases are available with a built-in 110/220 VAC power supply. The 5 slot base is also available with a built-in 24 VDC power supply.

Remote I/O is not offered in the DL305 product family. All DL305 products, with the exception of the DL340 CPU, are compatible with remote I/O systems previously offered by GE FANUC® and TEXAS INSTRUMENTS®

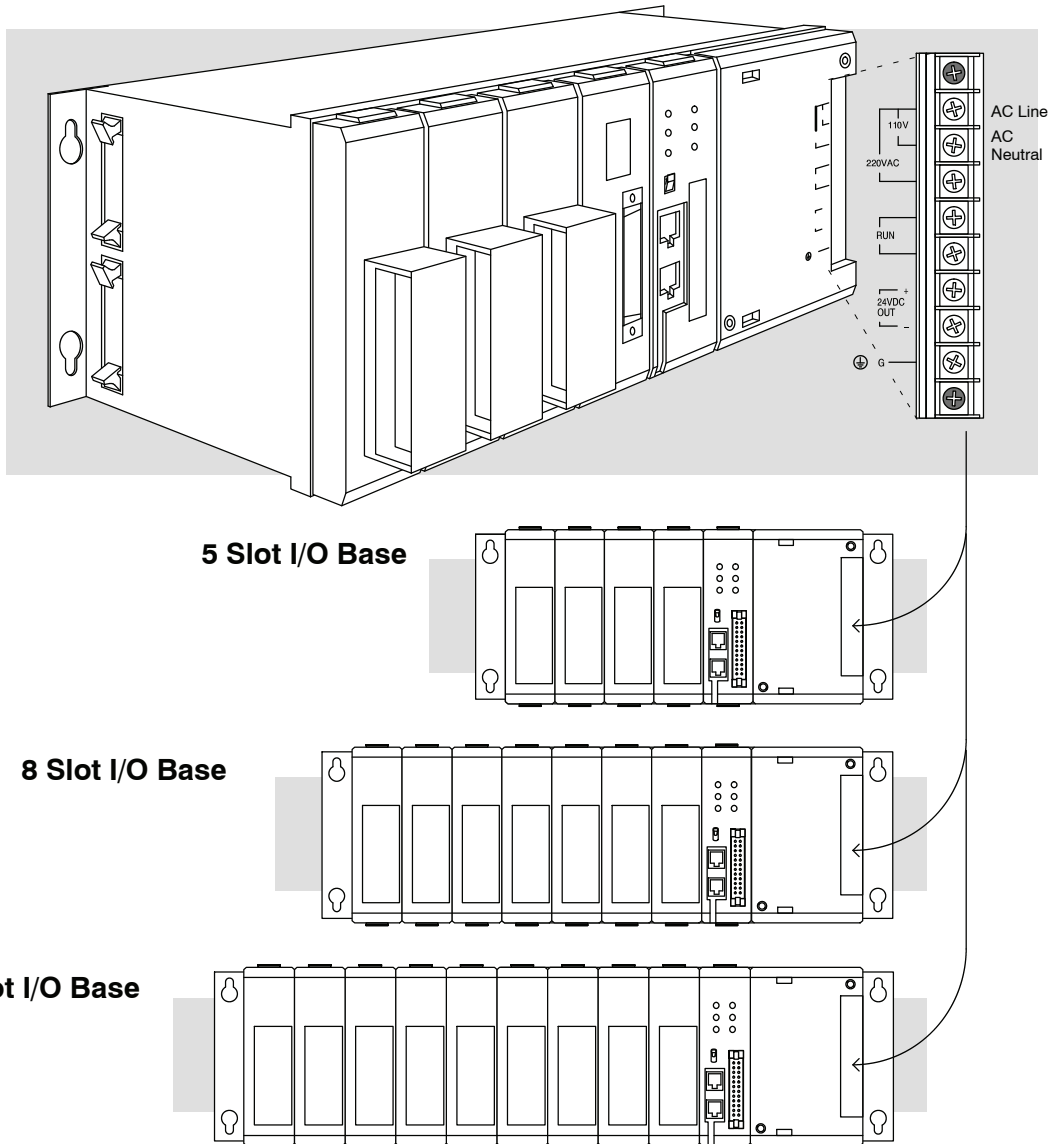

### Bases and Maximum I/O Supported

The maximum I/O for the base combinations is shown below. The number of I/O points supported also depends on the which CPU is used in the system.

Base Configuration	DL330 / DL330P CPU	DL340 CPU
5 slot local CPU base system	64 I/O max.	64 I/O max
5 slot local CPU base system with a 5 slot expansion base	120 I/O max.	128 I/O max.
5 slot local CPU base system with two 5 slot expansion bases	120 I/O max.	128 I/O max.
8 slot local CPU base system	112 I/O max.	112 I/O max.
8 slot local CPU base system with a 5 slot expansion base	152 I/O max.	152 I/O max.
10 slot local CPU base system	128 I/O max.	136 I/O max.
10 slot local CPU base system with a 5 slot expansion base	168 I/O max.	176 I/O max.
10 slot local CPU base system with a 10 slot expansion base	176 I/O max.	184 I/O max.

### Base Mounting Dimensions

Use these mounting dimensions when you install the DL305 bases. Make sure you have followed the installation guidelines shown in Chapter 2 for proper spacing.

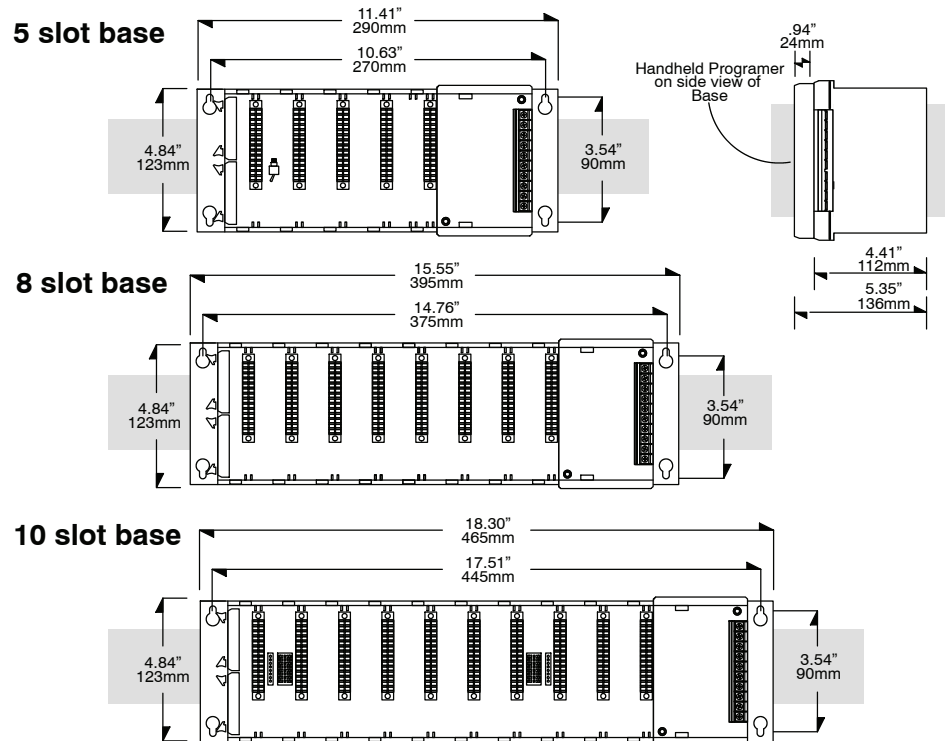

Bases, Expansion Bases and I/O Configuration

**Connecting the Power Supply**

The following diagram shows the terminal connections located on the power supply of the DL305 bases.



**WARNING: Damage will occur to the base power supply if 230 VAC is connected to the 115 VAC terminal connections. Once the power wiring is connected, install the protective cover. When the cover is removed there is a risk of electrical shock if you accidentally touch the connection terminals.**

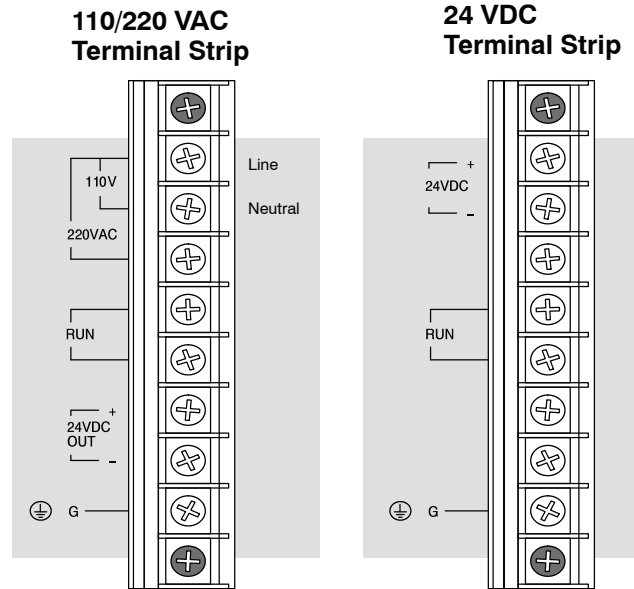

**Expansion Base Power Supply Wiring Example**

The following diagram shows how to connect the power when you use both local CPU and Expansion bases.

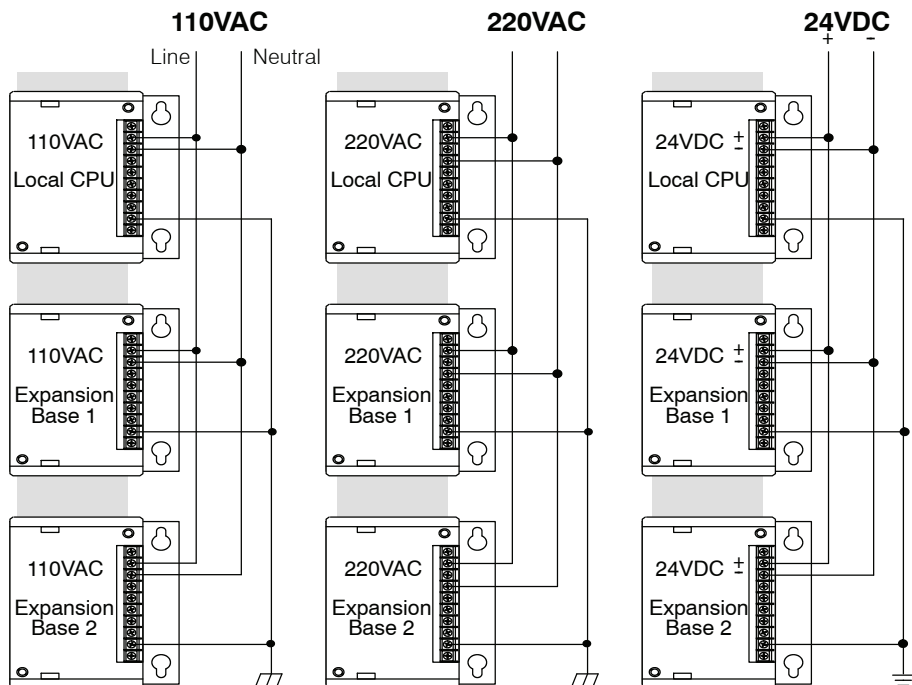

Bases, Expansion Bases and I/O Configuration

## Base Specifications

	D3-05B	D3-05BDC	D3-08B	D3-10B
<b>Number of Slots</b>	5	5	8	10
<b>Local CPU Base</b>	Yes	Yes	Yes	Yes
<b>Expansion Base</b>	Yes	Yes	No	Yes
<b>Input Voltage Range</b>	97-132 VAC 194-264 VAC 47-63Hz	20.5-30 VDC <10% ripple	97-132 VAC 194-264 VAC 47-63Hz	97-132 VAC 194-264 VAC 47-63Hz
<b>Base Power Consumption</b>	70 VA max (46W)	48 Watts	70 VA max (57W)	70 VA max (57W)
<b>Inrush Current max.</b>	30A	30A	30A	30A
<b>Dielectric Strength</b>	1500VAC for 1 minute between terminals of AC P/S, Run output, Common, 24VDC	1500VAC for 1 minute between 24VDC input terminals and Run output	1500VAC for 1 minute between terminals of AC P/S, Run output, Common, 24VDC	2000VAC for 1 minute between terminals of AC P/S, Run output, Common, 24VDC
<b>Insulation Resistance</b>	>10M $\Omega$ at 500VDC	>10M $\Omega$ at 500VDC	>10M $\Omega$ at 500VDC	>10M $\Omega$ at 500VDC
<b>Power Supply Output (Voltage Ranges and Ripple)</b>	(5VDC) 4.75-5.25V less than 0.1V p-p (9VDC) 8.5-13.5V less than 0.2V p-p (24VDC) 20-28V less than 1.2V p-p	(5VDC) 4.75-5.25V less than 0.1V p-p (9VDC) 8.5-13.5V less than 0.2V p-p (24VDC) 20-28V less than 1.2V p-p	(5VDC) 4.75-5.25V less than 0.1V p-p (9VDC) 8.0-12.0V less than 0.2V p-p (24VDC) 20-28V less than 1.2V p-p	(5VDC) 4.75-5.25V less than 0.1V p-p (9VDC) 8.0-12.0V less than 0.2V p-p (24VDC) 20-28V less than 1.2V p-p
<b>5 VDC current available</b>	1.4A *	1.4A	1.4A @ 122° F (50° C) 1.0A @ 140° F (60° C)	1.4A @ 122° F (50° C) 1.0A @ 140° F (60° C)
<b>9 VDC current available</b>	0.8A *	0.8A	1.7A @ 122° F (50° C) 1.4A @ 140° F (60° C)	1.7A @ 122° F (50° C) 1.4A @ 140° F (60° C)
<b>24 VDC current available</b>	0.5A *	0.5A	0.6A	0.6A
<b>Auxiliary 24 VDC Output</b>	100mA max	None	100mA max	100mA max
<b>Run Relay</b>	250 VAC, 4A (resistive load)	250 VAC, 4A (resistive load)	250 VAC, 4A (resistive load)	250 VAC, 4A (resistive load)
<b>Fuses</b>	2A (250V) User replaceable	4A (250V) User replaceable	2A (250V) User replaceable	2A (250V) User replaceable
<b>Dimensions WxHxD</b>	11.42x4.85x4.41 in. (290x123x112 mm)	11.42x4.85x4.41 in. (290x123x112 mm)	15.55x4.85x4.41 in. (395x123x112 mm)	18.3x4.85x4.41 in. (465x123x112 mm)
<b>Weight</b>	34 oz. (964g)	34 oz. (964g)	44.2 oz. (1253g)	50.5 oz. (1432g)

\* The total current for the D3-05B must not exceed 2.3A.

### Auxiliary 24VDC Output at Base Terminal

There is 24 VDC available from the 24 VDC output terminals on all bases except the 5 slot DC version (D3-05BDC). The 24 VDC supply can be used to power external devices or DL305 modules that require external 24 VDC. The power used from the this 24 VDC output reduces the internal system 24 VDC available to the modules by an equal amount. So if you use this power supply, make sure you consider this when you calculate the power budget. (The power budget is discussed in more detail later in this chapter.)

**Power Supply Schematics**

The following diagram shows the details of how the DL305 base provides many of the specifications listed on the previous page.

**Schematic for D3-05B, D3-08B, D3-10B**

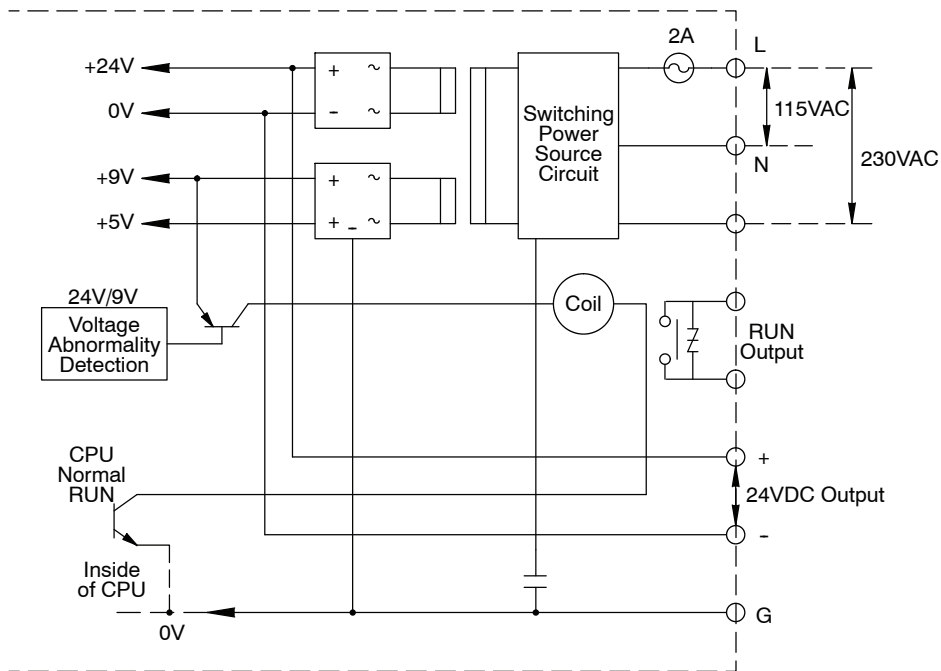

**Schematic for D3-05BDC**

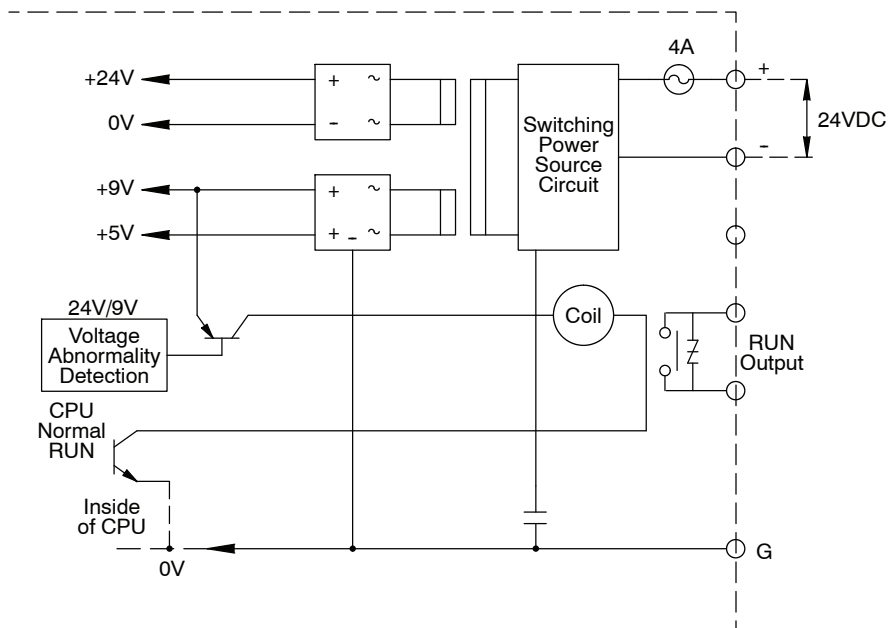

Bases, Expansion Bases and I/O Configuration

### Using the Run Relay on the Base Power Supply

The RUN relay output, located on the DL305 base power supply, can be used to detect an undesired failure on the local CPU base or an expansion base. The following table shows the operating characteristics of the RUN relay for a local CPU base or an expansion base.

Event	Local CPU Base RUN Relay Would:	Expansion Base RUN Relay Would:
PROGRAM to RUN mode Transition	Energize	Not change
The CPU detects a fatal error	De-energize	Not change
CPU Local Base is Removed Form the RUN Mode	De-energize	Not change
Power Source to the Power Supply is Turned OFF	De-energize	De-energize
9 VDC or 24 VDC Failure on the Power Supply	De-energize	De-energize

The following example demonstrates possible uses for the RUN relay on the DL305 bases.

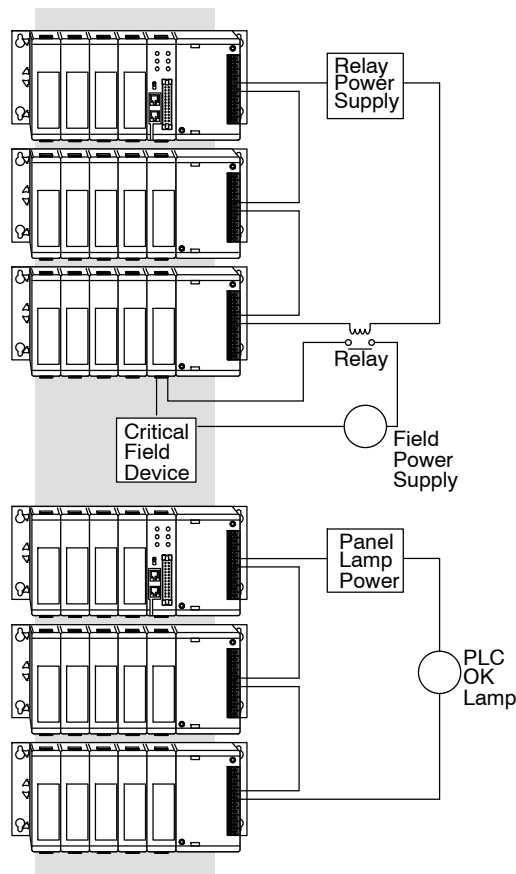

Use of the RUN relay to shutdown critical field devices upon error detection

Use of the RUN relay to monitor system operation

### Installing CPUs and I/O Modules

The CPU must go into first slot (next to the power supply) on the far right side of the base. When inserting components into the base, align the PC board(s) of the module with the grooves on the top and bottom of the base. Push the module straight into the base until it is firmly seated in the backplane connector. To remove a module from the base squeeze the tabs on the top and bottom of the faceplate and pull the module straight out.

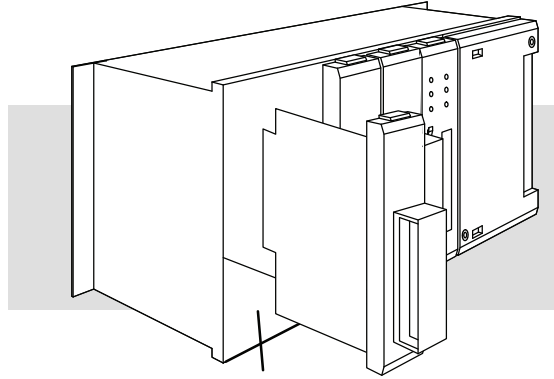

Align module to slots in base and slide in



**WARNING: Do not remove any system component when system power is on. This may cause damage to the system or unpredictable system operation that can result in a risk of personal injury.**



## Using Bases for Local or Expansion I/O Systems

**Base Uses Table** It is helpful to understand how you can use the various DL305 bases in your control system. The following table shows how the bases can be used.

Base Part #	Number of Slots	Can Be Used As A Local CPU Base	Can Be Used As An Expansion Base
D3-05B	5	Yes	Yes
D3-05BDC	5	Yes	Yes
D3-08B	8	Yes	No
D3-10B	10	Yes	Yes

**Local/Expansion Connectivity** The configurations below show the valid combinations of local CPU bases and expansion bases.



**NOTE:** You should use one of the configurations listed below when designing an expansion system. If you use a configuration not listed below the system will not function properly.

5 slot local CPU base with a maximum of two 5 slot expansion bases

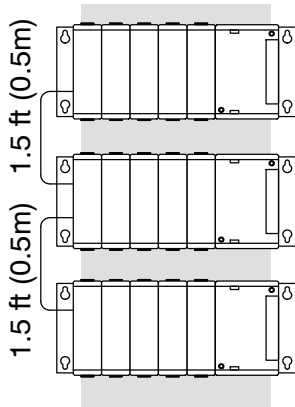

8 slot local CPU base with a 5 slot expansion base

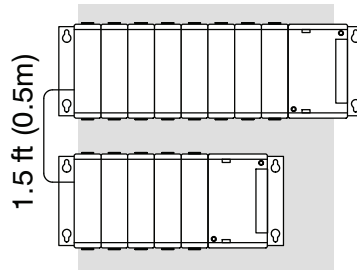

10 slot local CPU base with a 5 slot expansion base

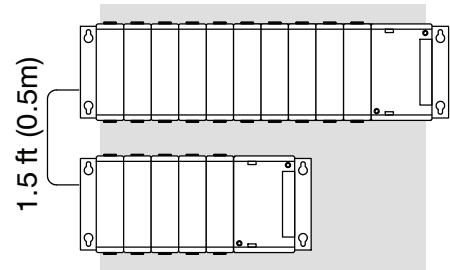

10 slot local CPU base with a 10 slot expansion base

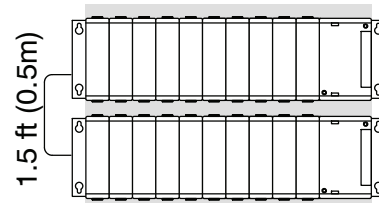

**Connecting Expansion Bases**

The local CPU base is connected to the expansion base using a 1.5 ft. cable (D3-EXCBL). The base must be connected as shown in the diagram below.

The top expansion connector on the base is the input from a previous base. The bottom expansion connector on the base is the output to an expansion base. The expansion cable is marked with "CPU Side" and "Expansion Side". The "CPU Side" of the cable is connected to the bottom port of the base and the "Expansion Side" of the cable is connected to the top port of the next base.

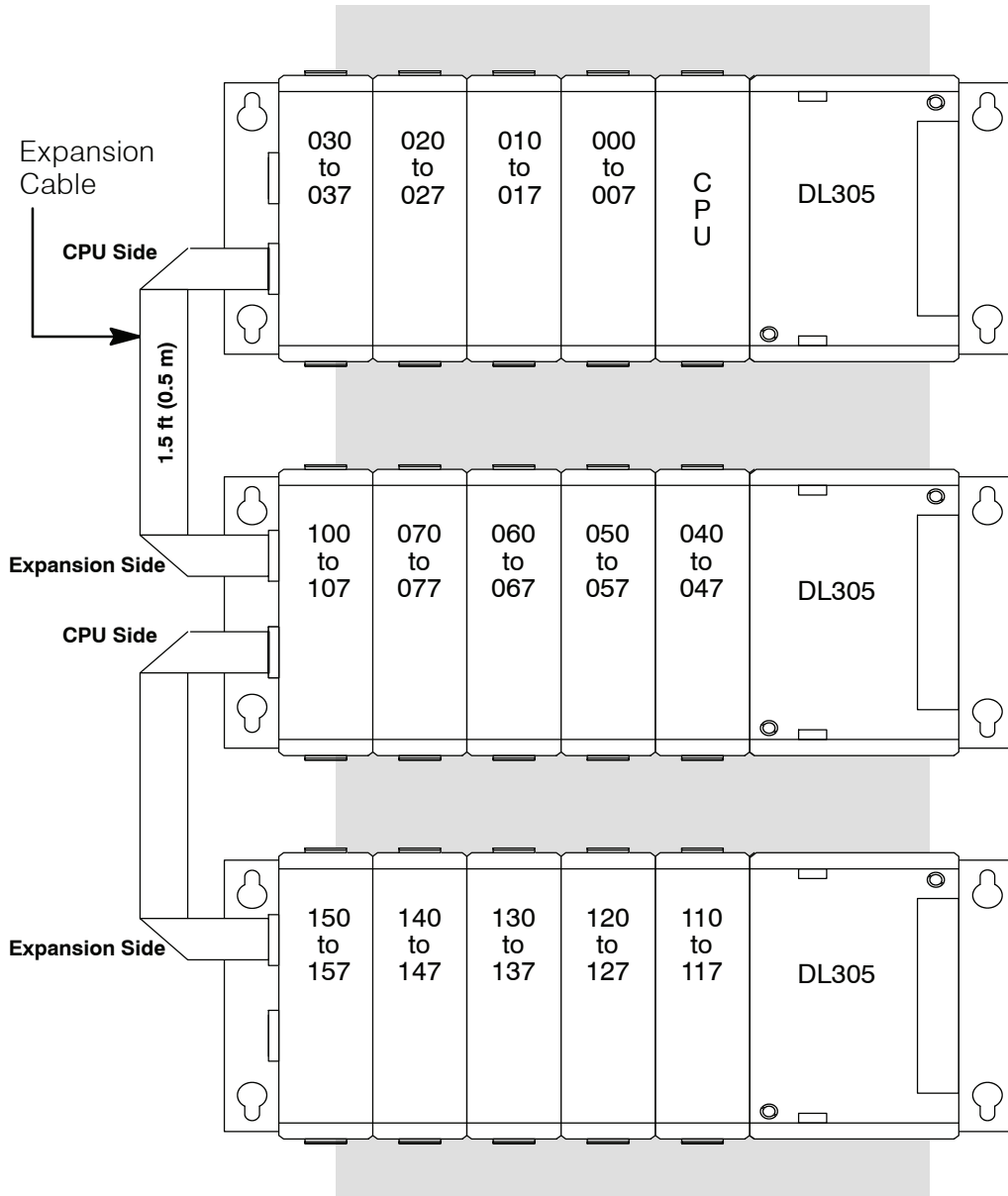

Note: Avoid placing the expansion cable in the same wiring tray as the I/O and power source wiring.

## Setting the Base Switches

The 5 slot and 10 slot bases have jumper switches that need to be set depending on which system configuration is used. The 8 slot base does not have any switches.

### 5 Slot Bases

The 5 slot bases have a two position toggle switch which is used to set the base as the CPU local base, the first expansion base, or the second (last) expansion base.

The switch is set to the “1,3” position if the base is the local CPU base or the third base in the system. The switch is set to the “2” position if the base is the 2nd base in the system. If the 5 slot base is used as an expansion base for a 10 slot local CPU base the switch is set in the “1,3” position.

See Errata Sheet at the beginning of this file. Newer 5 slot bases have a jumper switch instead of a toggle switch to set the base as the CPU local base or as an expansion base.

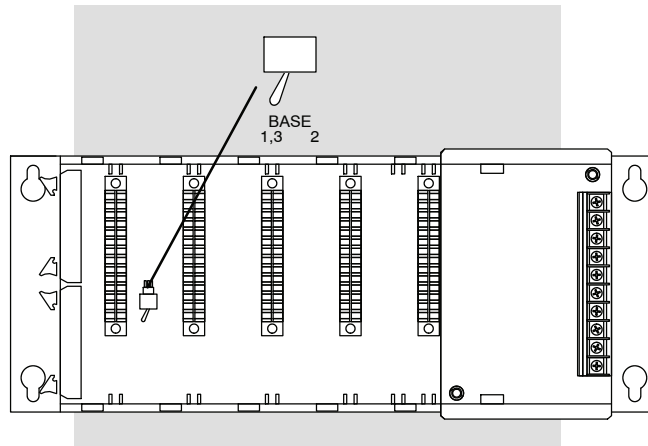

### 10 Slot Base

The 10 slot base has a jumper switch between slot 3 and 4 used to set the base to local CPU base or expansion base. There is also a jumper switch between slot 9 and 10 that sets slot 10 to the 100-107 I/O address range or to the 700-707 I/O address range.

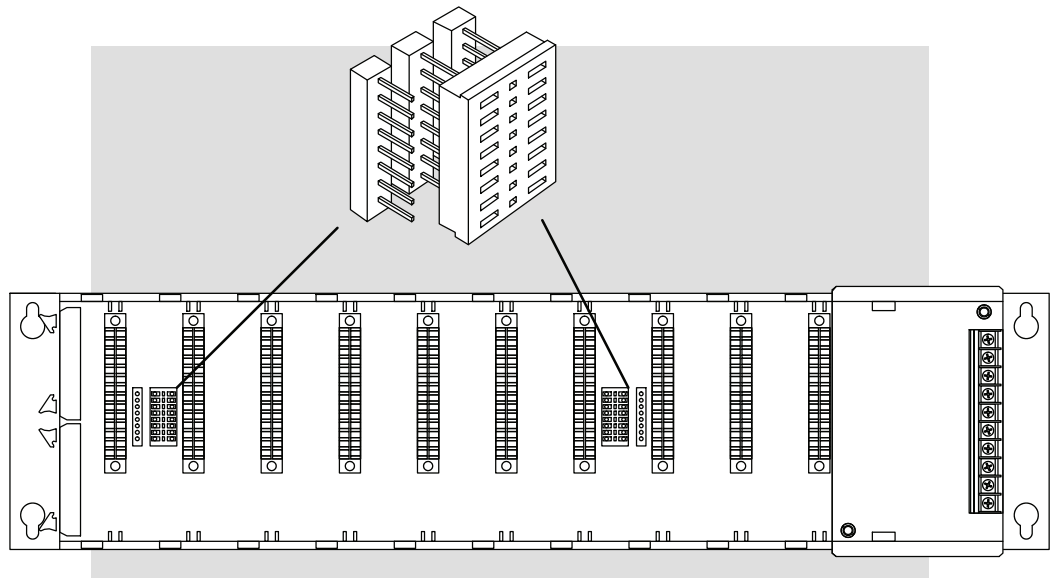

## Example I/O Configurations

The following system configurations will allow you to quickly configure your system by using examples. These system configurations show the I/O numbering and the base switch settings for every valid base configuration for a DL305 system.

### 16 Point I/O Allocation Example

When a 16 point I/O module is used the last 8 I/O addresses of each 16 point module could have been used in another base slot. In the illustration below Example A shows a 16 point module in the slot next to the CPU using address 000-007 and 100-107. The expansion I/O cannot use the last slot of the expansion base since it is assigned addresses 100-107 and the 16 point module next to the CPU has already used these addresses. Example B shows an 8 point module in the slot next to the CPU and an 8 point module in the last slot of the expansion base. Both examples are valid configurations .

See Errata Sheet at the beginning of this file. Newer 5 slot bases have a jumper switch instead of a toggle switch to set the base as the CPU local base or as an expansion base.

Example A

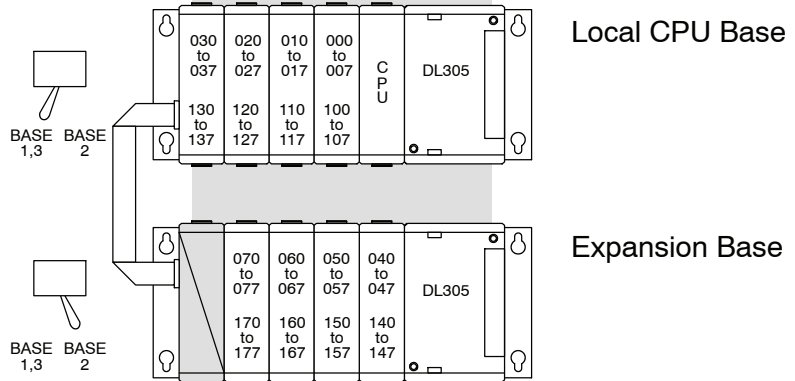

Example B

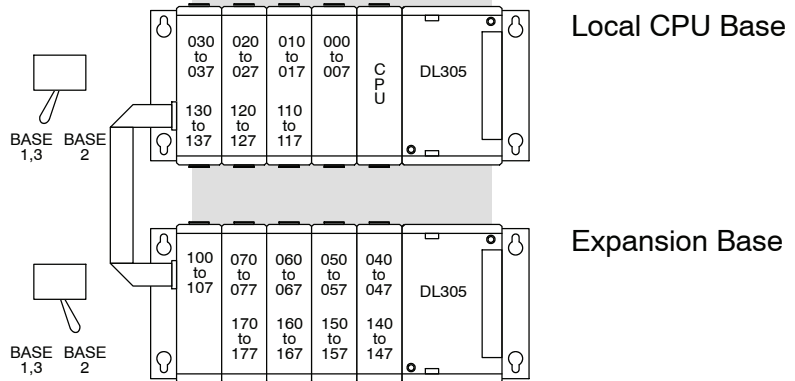

### Examples Show Maximum I/O Points Available

For the following examples the configurations using 16 point I/O modules are shown with the maximum I/O points supported so you can always reduce the I/O count in one of our examples and the configuration will still be valid. Substitution of 8 point I/O modules can be made in place of any of the 16 point modules without affecting the I/O numbering for any of the other I/O modules. When a 16 point module is replaced with a 8 point I/O module the last 8 I/O addresses of that 16 point module may or may not be useable in another slot location, depending on the system configuration used

## I/O Configurations with a 5 Slot Local CPU Base

The configurations below and on the next few pages show a 5 slot base with 8 point I/O modules, 16 point modules, one expansion base and two expansion bases.

### Switch settings

The 5 slot base has a toggle switch on the inside of the base between slots 4 and 5 which allows you to select:

Type of Base	Switch Position
Local CPU	Base 1,3
First Expansion	Base 2*
Last Expansion	Base 1,3

\*used only with a 5 slot local CPU base

### 5 Slot Base with 8 Point I/O

Total I/O: 32

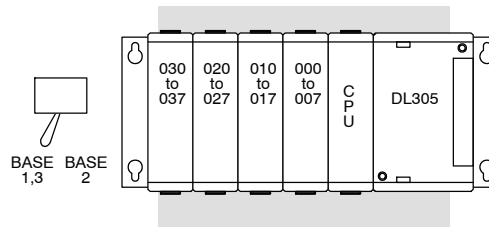

### 5 Slot Base with 16 Point I/O

Total I/O: 64

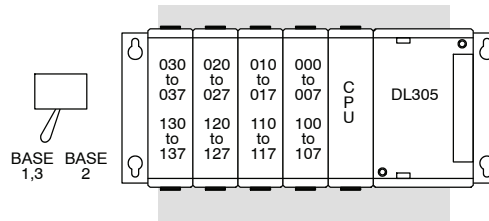

See Errata Sheet at the beginning of this file. Newer 5 slot bases have a jumper switch instead of a toggle switch to set the base as the CPU local base or as an expansion base.

### 5 Slot Base and 5 Slot Expansion Base with 8 Point I/O

Total I/O: 72

See Errata Sheet at the beginning of this file. Newer 5 slot bases have a jumper switch instead of a toggle switch to set the base as the CPU local base or as an expansion base.

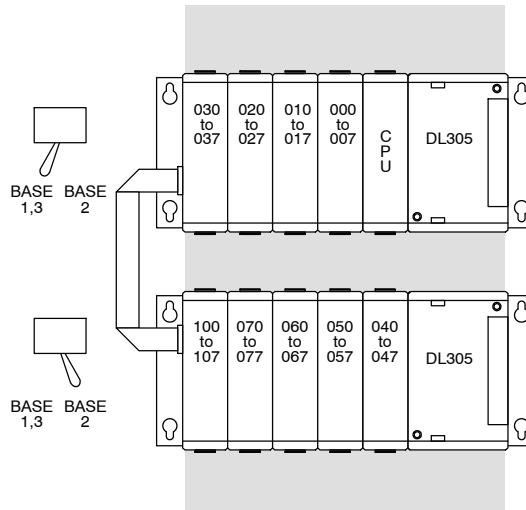

### 5 Slot Base and 5 Slot Expansion Base with 16 Point I/O

Total I/O: 128

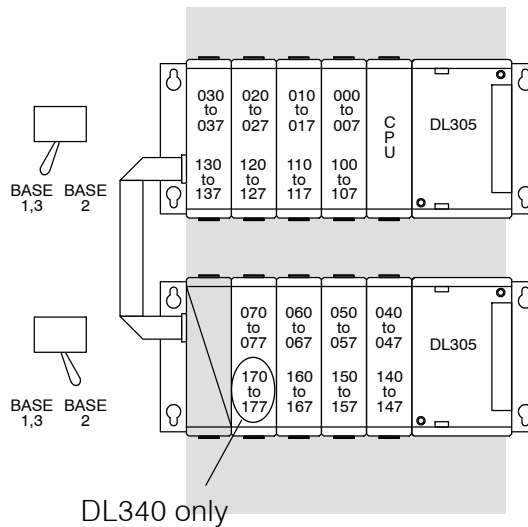

**NOTE:** If a 16pt module is used in the last two available slots of the expansion base, 160 through 177 will not be available for control relay assignments. Also, even though you are using these points as I/O, you still enter them as C160-C177 in *DirectSOFT*.

### 5 Slot Base and Two 5 Slot Expansion Bases with 8 Point I/O

Total I/O: 112

See Errata Sheet at the beginning of this file. Newer 5 slot bases have a jumper switch instead of a toggle switch to set the base as the CPU local base or as an expansion base.

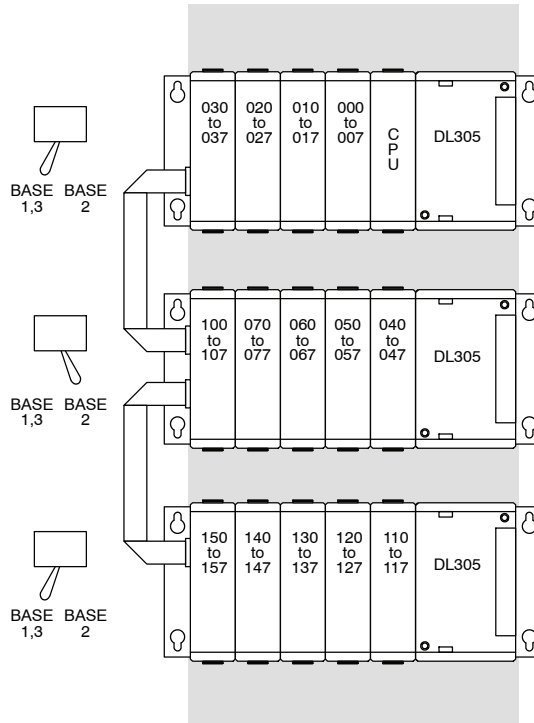

### 5 Slot Base and Two 5 Slot Expansion Bases with 16 and 8 Point I/O

Total I/O: 128

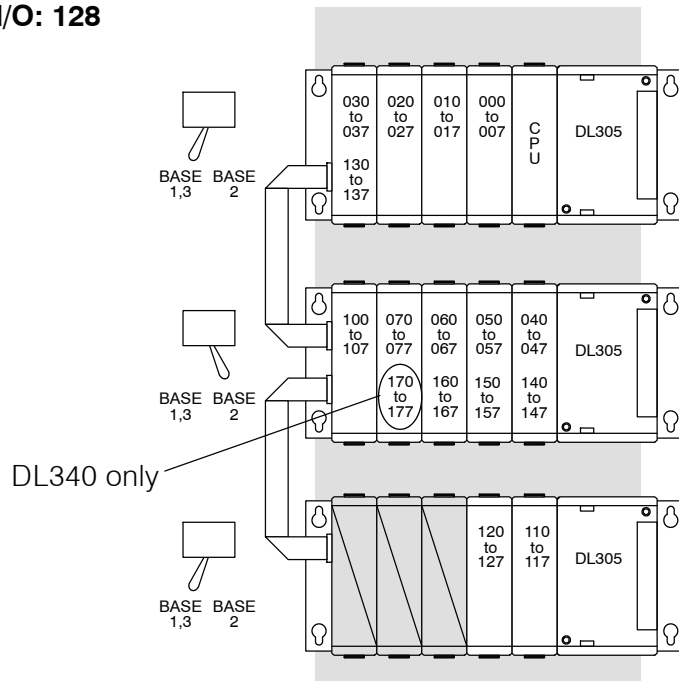

**NOTE:** If a 16pt module is used in the last two available slots of the expansion base, 160 through 177 will not be available for control relay assignments. Also, even though you are using these points as I/O, you still enter them as C160-C177 in **DirectSOFT**.

# I/O Configurations with an 8 Slot Local CPU Base

The configurations below show an 8 slot base with 8 point I/O modules, 16 point modules, one 5 slot expansion base and two 5 slot expansion bases.

**8 Slot Base with 8 Point I/O**

**Total I/O: 56**

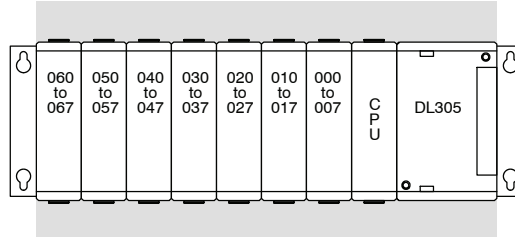

**8 Slot Base with 16 Point I/O**

**Total I/O: 112**

**\*See note below regarding points 160-167**

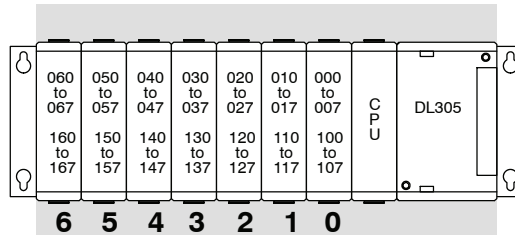

**8 Slot Base and 5 Slot Expansion Base with 8 Point I/O**

**Total I/O: 96**

See Errata Sheet at the beginning of this file. Newer 5 slot bases have a jumper switch instead of a toggle switch to set the base as the CPU local base or as an expansion base.

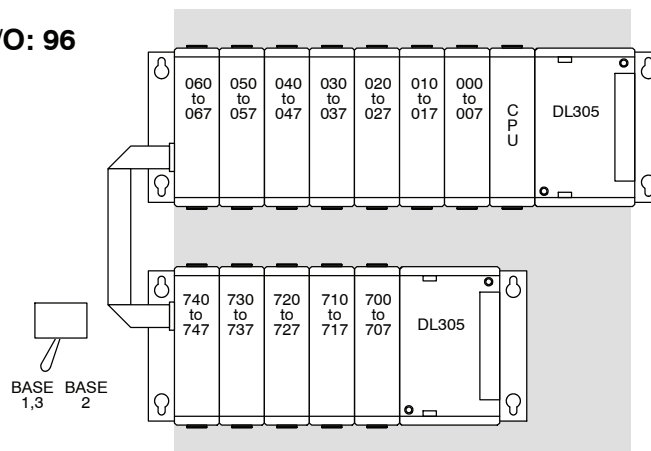

**8 Slot Base and 5 Slot Expansion Base with 16 Point I/O**

**Total I/O: 152**

**\*See note below regarding points 160-167**

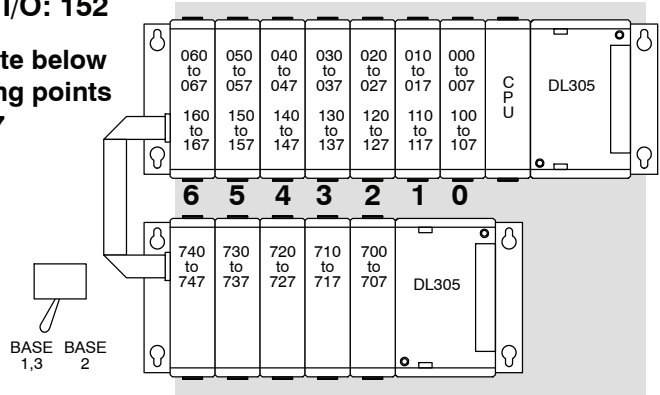

**NOTE:** If a 16pt module is used in Slot 6, 160 through 167 will not be available for control relay assignments. Also, even though you are using these points as I/O, you still enter them as C160-C167 in **DirectSOFT**.

Bases, Expansion Bases and I/O Configuration



## I/O Configurations with a 10 Slot Local CPU Base

The configurations below and on the next few pages show a 10 slot base with 8 point I/O modules, with 16 point modules, with a 5 slot expansion base and with a 10 slot expansion base.

### Switch settings

The 10 slot base has two jumper switches to select the base type and the address ranges to use. These switches can be found on the base between slots 3 and 4 (SW1) and slots 9 and 10 (SW2). Jumper switch SW1 is used to select if the base is a local CPU base or an expansion base. Jumper switch SW2 determines the I/O address range (100 - 107 or 700 - 707) for the 10th slot on the local CPU base. By selecting the address range of 700 to 707 for slot 10, it is possible to use a 16 point module next to the CPU (which uses the ranges of 000 to 007 and 100 to 107), however; the position of this switch will affect the I/O numbering for the expansion I/O if used.



**NOTE:** Jumper switch SW2 must be set to “100 EXP” on the expansion base.

### Last Slot Address Range 100 to 107

Total I/O: 72

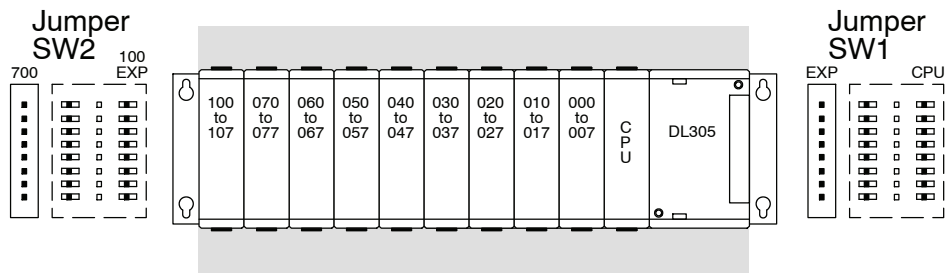

### Last Slot Address Range 700 to 707

Total I/O: 72

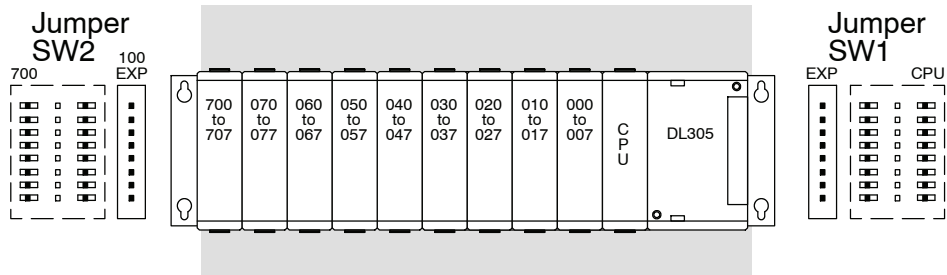

**10 Slot Expansion Base with 16 Point I/O**

The next two configurations show a local CPU base using 16 point I/O modules and the two possibilities for how to configure the base to use the maximum number of I/O points.

**Configuration 1**

Configuration 1 shows an 8 point I/O module the slot next to the CPU and the address range of 100-107 for the last slot. When jumper switch SW2 is set to the "100 EXP" position, the address range for the last slot is set to 100-107, thereby limiting the address range for the first module to 000-007. This means if you use this configuration, the first module must be an 8 point I/O module. You will have more available addresses for an expansion base as you will see in the example using a 10 slot expansion base.

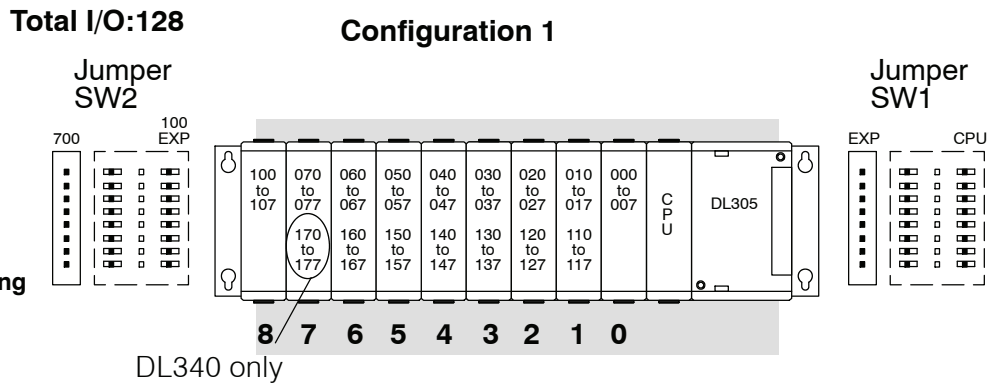

\*See note below regarding points 160-167 and 170-177.

**Configuration 2**

Configuration 2 shows a 16 point I/O module in the slot next to the CPU and the address range of 700-707 for the last slot. This is the maximum I/O configuration for a 10 slot local CPU base. When jumper switch SW2 is set to the "700" position the address range for the last slot is set to 700-707 making addresses 000-007 and 100-107 available for use in the first slot. The position of jumper switch SW2 can limit the amount of I/O addresses available to the larger expansion bases since expansion I/O numbering would normally start with address 700.

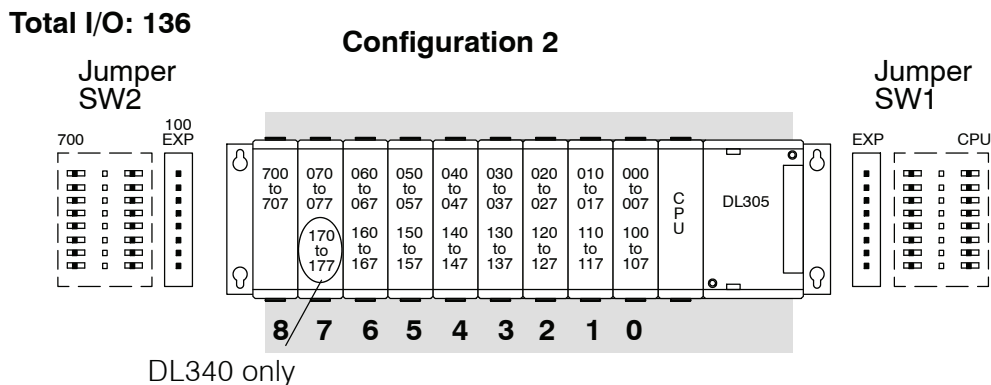

\*See note below regarding points 160-167 and 170-177.



**NOTE:** If a 16pt module is used in Slot 6 for the DL330 or DL330P CPU, 160 through 167 will not be available for control relay assignments. If a 16pt module is used in Slot 6 and/or Slot 7 for a DL340 CPU, 160-167 and/or 170-177 are not available for control relay assignments. Also, even though you are using these points as I/O, you still enter them as C160-C167/C170-C177 in **DirectSOFT**.

Bases, Expansion Bases and I/O Configuration

### 10 Slot Base and 5 Slot Expansion Base with 16 Point I/O

Total I/O: 176

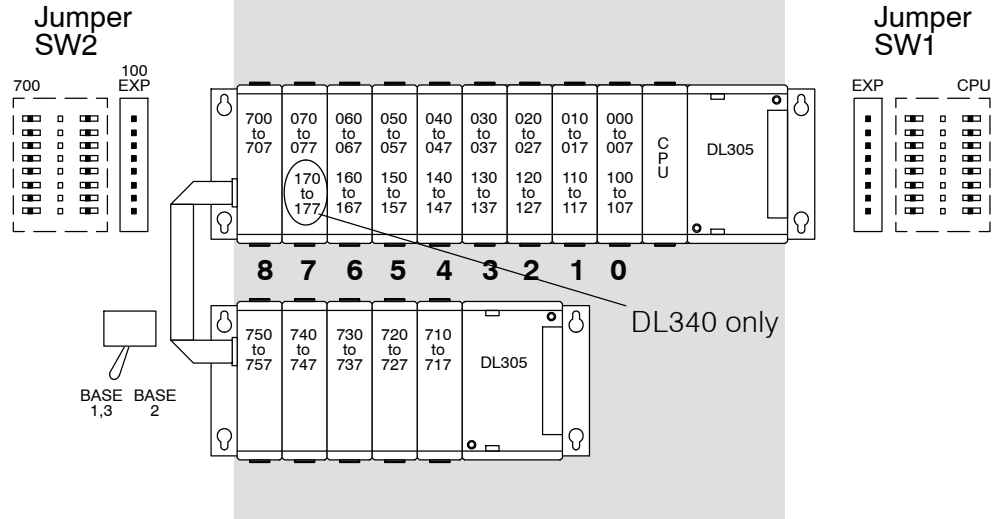

**NOTE:** If a 16pt module is used in Slot 6 for the DL330 or DL330P CPU, 160 through 167 will not be available for control relay assignments. If a 16pt module is used in Slot 6 and/or Slot 7 for a DL340 CPU, 160-167 and/or 170-177 are not available for control relay assignments. Also, even though you are using these points as I/O, you still enter them as C160-C167/C170-C177 in *DirectSOFT*.

**Expansion Addresses Depend on Local CPU Base Configuration.**

I/O addresses change depending on the point configuration in the local CPU base. Notice, when the local CPU base contains only 8 point I/O modules, addresses 110-117, 120-127 and 130-137 are available for use in the expansion base. When the local CPU base has 16 point I/O modules, which use the I/O addresses 110-117, 120-127 and 130-137, these addresses are taken up and are not available for use in the expansion base.

**10 Slot Base and 10 Slot Expansion Base with 8 Point I/O**

Total I/O: 152

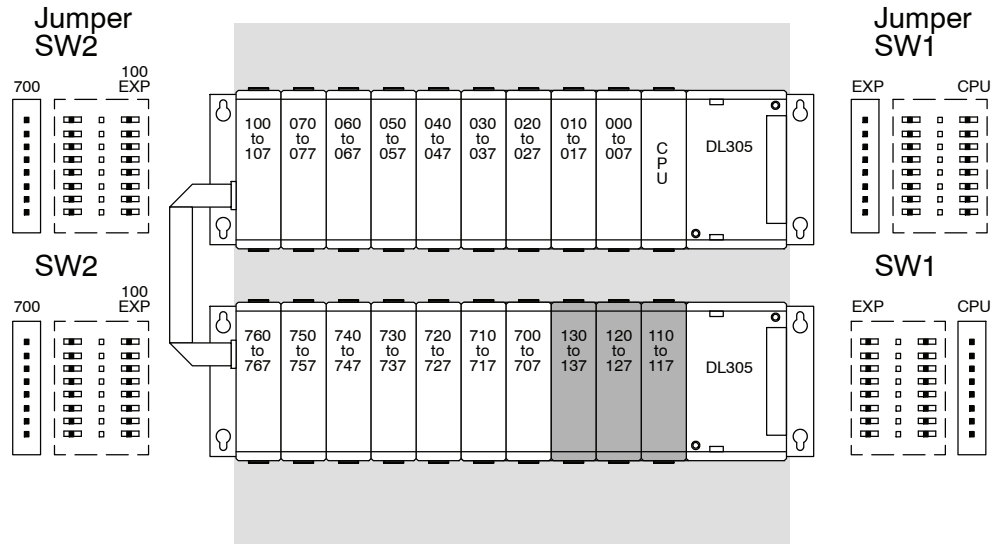

**10 Slot Base and 10 Slot Expansion Base with 16 Point I/O**

Total I/O: 184

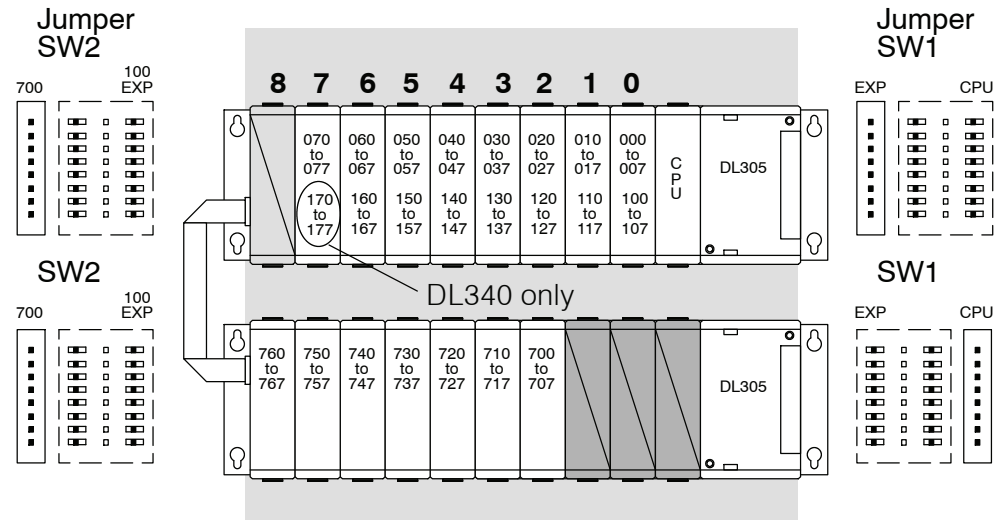

**NOTE:** If a 16pt module is used in Slot 6 for the DL330 or DL330P CPU, 160 through 167 will not be available for control relay assignments. If a 16pt module is used in Slot 6 and/or Slot 7 for a DL340 CPU, 160-167 and/or 170-177 are not available for control relay assignments. Also, even though you are using these points as I/O, you still enter them as C160-C167/C170-C177 in *DirectSOFT*.

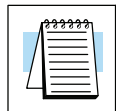

Bases, Expansion Bases and I/O Configuration

## Calculating the Power Budget

### Managing your Power Resource

When you determine the types and quantity of I/O modules you will be using in the DL305 system it is important to remember there is a limited amount of power available from the power supply. We have provided a chart to help you easily see the amount of power available with each base. The following chart will help you calculate the amount of power you need with your I/O selections. At the end of this section you will also find an example of power budgeting and a worksheet for your own calculations.

If the I/O you choose exceeds the maximum power available from the power supply you can resolve the problem in one of two ways:

- Shift some of the modules to an expansion base which contains another power supply.
- If a 5 slot base is being used, replace it with an 8 or 10 slot base. This will provide more power on the 9V and 24V power supplies.

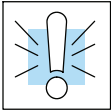

**WARNING:** It is *extremely* important to calculate the power budget. If you exceed the power budget, the system may operate in an unpredictable manner which may result in a risk of personal injury or equipment damage.

### Auxiliary Base Power Source

There is 24 VDC available from the 24 VDC output terminals on the bases (except D3-05BDC). The 24 VDC can be used to power external devices or DL305 modules that require external 24 VDC. The power used from this supply reduces the internal system 24 VDC available to the modules by an equal amount. When using the 24 VDC output at the base terminal it is not recommended to exceed 100mA.

### Base Power Specifications

This chart shows the amount of current available for the three voltages supplied on DL305 bases. Use these currents when calculating the power budget for your system.

Bases	5V Power Supplied in mA	9V Power Supplied in mA	24V Power Supplied in mA	Auxiliary 24 VDC Output at Base Terminal
D3-05B	1400	800	500	Yes
D3-05BDC	1400	800	500	None
D3-08B	1400	1700	600	Yes
D3-10B	1400	1700	600	Yes



**NOTE:** The total current for the D3-05B and D3-05BDC should not exceed 2.3 Amps. The base currents listed for the D3-08B and the D3-10B are for operating ambient temperatures between 0° C and 50° C.

## Module Power Requirements

The next three pages show the amount of maximum current required for each of the DL305 modules. The column labeled “External Power Source Required” is for module operation and is not for field wiring. Use these currents when calculating the power budget for your system. If 24 VDC is needed for external devices, the 24 VDC (100mA maximum) output at the base terminal strip may be used as long as the power budget is not exceeded.

	5V Power Required in mA	9V Power Required in mA	24V Power Required in mA	External Power Source Required
<b>CPUs</b>				
D3-330	300	50	0	None
D3-330P	300	50	0	None
D3-340	300	20	0	None
<b>Specialty CPUs</b>				
F3-OMUX-1	300	0	0	None
F3-OMUX-2	300	0	150	None
F3-PMUX	500	0	0	None
F3-RTU	300	0	0	0
<b>DC Input Modules</b>				
D3-08ND2	0	10	112	None
D3-16ND2-1	0	25	224	None
D3-16ND2-2	0	24	209	None
D3-16ND2F	0	25	224	None
F3-16ND3F	0	148	68	None
<b>AC Input Modules</b>				
D3-08NA-1	0	10	0	None
D3-08NA-2	0	10	0	None
D3-16NA	0	100	0	None
<b>AC/DC Input Modules</b>				
D3-08NE3	0	10	0	None
D3-16NE3	0	130	0	None

**Module Power Requirements  
(continued)**

	5V Power Required in mA	9V Power Required in mA	24V Power Required in mA	External Power Source Required
<b>DC Output Modules</b>				
D3-08TD1	0	20	24	None
D3-08TD2	0	30	0	None
D3-16TD1-1	0	40	96	None
D3-16TD1-2	0	40	96	None
D3-16TD2	0	180	0	None
<b>AC Output Modules</b>				
D3-04TAS	0	12	0	None
F3-08TAS	0	80	0	None
F3-08TAS-1	0	25	0	None
D3-08TA-1	0	96	0	None
D3-08TA-2	0	160	0	None
F3-16TA-2	0	250	0	None
D3-16TA-2	0	400	0	None
<b>Relay Output Modules</b>				
D3-08TR	0	360	0	None
F3-08TRS-1	0	296	0	None
F3-08TRS-2	0	296	0	None
D3-16TR	0	480	0	None
<b>Analog</b>				
D3-04AD	0	55	0	24VDC @ 65mA max
F3-04ADS	0	183	50	None
F3-08AD	0	25	37	None
F3-08TEMP	0	25	37	None
F3-08THM-n	0	50	34	None
F3-16AD	0	33	47	None
D3-02DA	0	80	0	24VDC @ 170mA max
F3-04DA-1	0	144	108	None
F3-04DA-2	0	144	108	None
F3-04DAS	0	154	145	None

	5V Power Required in mA	9V Power Required in mA	24V Power Required in mA	External Power Source Required
<b>Communications and Networking</b>				
D3-232-DCU	500	0	0	Optional 5VDC @ 500mA
D3-422-DCU	500	0	0	Optional 5VDC @ 500mA
F3-UNICON	0	0	0	(24 VDC or 5 VDC) @ 100mA
<b>ASCII BASIC Modules</b>				
F3-AB128-R	0	205	0	None
F3-AB128-T	0	205	0	None
F3-AB128	0	90	0	None
F3-AB64	0	90	0	None
<b>Specialty Modules</b>				
D3-08SIM	0	10	112	None
D3-HSC	0	70	0	None
D3-PWU	800	0	0	Optional 5VDC @ 800mA
<b>Programming</b>				
D3-HP	50	50	0	Optional
D3-HPP	50	50	0	Optional



**Power Budget  
Calculation  
Example**

The following example shows how to calculate the power budget for the DL305 system.

Base # 1	Module Type	5 VDC (mA)	9 VDC (mA)	24 VDC (mA) and/or Auxiliary Base Power Source 24 VDC Output (mA)
<b>Base Used</b>	D3-05B	<b>1400</b>	<b>800</b>	<b>500</b>
Slot 1	D3-330	+ 300	+ 50	+ 0
Slot 2	D3-16NE3	+ 0	+ 130	+ 0
Slot 3	D3-16NE3	+ 0	+ 130	+ 0
Slot 4	F3-16TA-2	+ 0	+ 250	+ 0
Slot 5	F3-16TA-2	+ 0	+ 250	+ 0
Slot 6				
Slot 7				
Slot 8				
Slot 9				
Slot 10				
Other	D3-232-DCU	+ 500	+ 0	+ 0
<b>Maximum power required</b>		<b>800</b>	<b>630</b>	<b>0</b>
<b>Remaining Power Available</b>		1400 - 800 = <b>600</b>	800 - 630 = <b>170</b>	500 - 0 = <b>500</b>

- Using the tables at the beginning of the Power Budgeting section of this chapter fill in the information for the Base, CPU, I/O modules, and any other devices that will use system power including devices that use the 24 VDC output. Pay special attention to the current supplied by the base which you have selected since they do differ. Devices which fall into the "Other" category are devices such as the Data Communications Unit and the Handheld programmer which plug onto the CPU.
- Add the current columns starting with slot 1 and put the total in the row labeled "Maximum power required".
- Subtract the row labeled "Maximum power required" from the row labeled "Base Used". Place the difference in the row labeled "Remaining Power Available".
- If "Maximum Power Required" is greater than "Base Used" in any of the three columns, the power budget will be exceeded. It will be unsafe to use this configuration and you will need to restructure your base/module configuration.

### Power Budget Calculation Worksheet

This blank chart is provided for you to copy and use in your power budget calculations.

Base # _____	Module Type	5 VDC (mA)	9 VDC (mA)	24 VDC (mA) and/or Auxiliary Base Power Source 24 VDC Output (mA)
<b>Base Used</b>				
Slot 1				
Slot 2				
Slot 3				
Slot 4				
Slot 5				
Slot 6				
Slot 7				
Slot 8				
Slot 9				
Slot 10				
<b>Other</b>				
<b>Maximum power required</b>				
<b>Remaining Power Available</b>				

- Using the tables at the beginning of the Power Budgeting section of this chapter fill in the information for the Base, CPU, I/O modules, and any other devices that will use system power including devices that use the 24 VDC output. Pay special attention to the current supplied by the base which you have selected since they do differ. Devices which fall into the "Other" category are devices such as the Data Communications Unit and the Handheld programmer which plug onto the CPU.
- Add the current columns starting with slot 1 and put the total in the row labeled "Maximum power required".
- Subtract the row labeled "Maximum power required" from the row labeled "Base Used". Place the difference in the row labeled "Remaining Power Available".
- If "Maximum Power Required" is greater than "Base Used" in any of the three columns, the power budget will be exceeded. It will be unsafe to use this configuration and you will need to restructure your base/module configuration.

