

Introduction

Is this the right manual for you?

This manual is designed to allow you to quickly install your DL305 Data Communications Unit (DCU). This is the only manual you will need if you are using the DCU as an interface for the **DirectSOFT** programming package or, as a communications port for an operator interface. If you plan on using the DCU as a slave interface on a **DirectNET** network, you should read the **DirectNET** manual first. The **DirectNET** manual provides detailed descriptions of the network configuration and protocol that is necessary to control communications with the DCUs.

DCU Hardware Overview

The following diagram shows the major DCU components. The address selection switches and the communication dipswitches are of special importance. Also, there are two versions of the DCU RS232C and RS422. You can use RS232C/RS422 converters with these units, but it is generally easier to use the version that is best suited for your application.

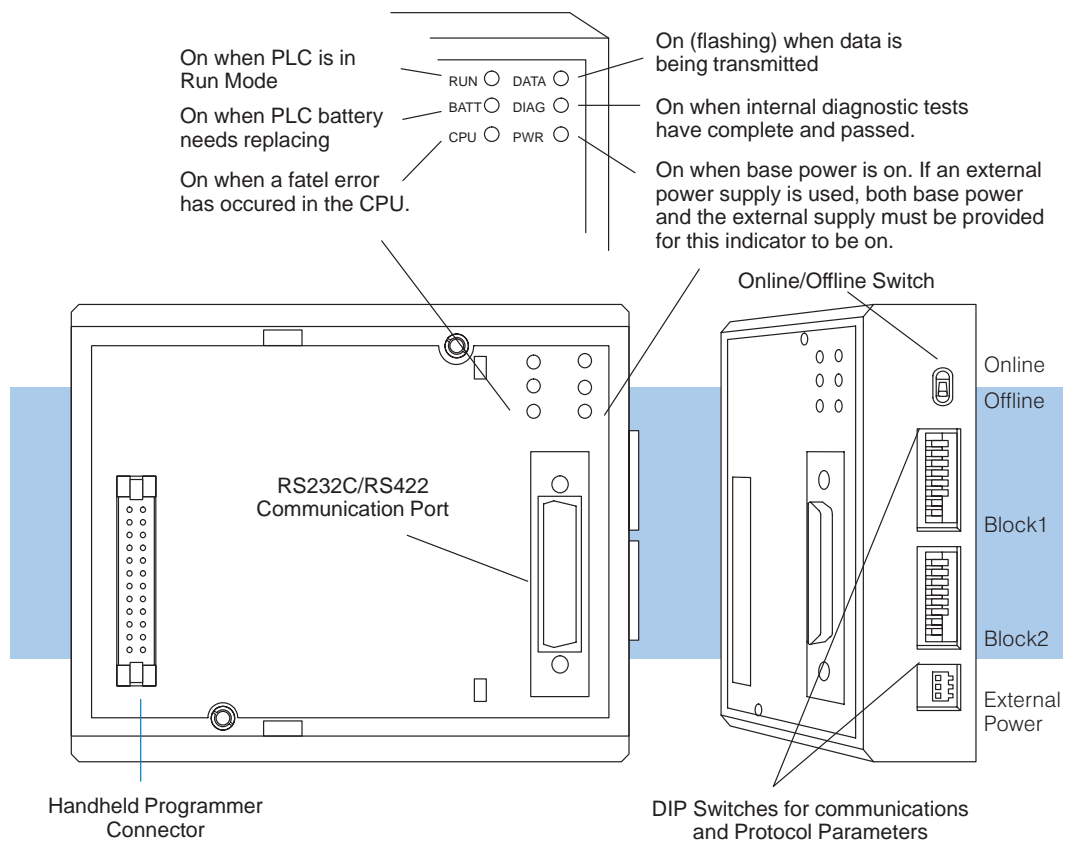

DCU Uses

The DL305 Data Communications Unit (DCU) is a communications interface for the DL305 family of Programmable Logic Controllers (PLCs). This module is primarily used for two reasons.

- As a general purpose communications port to connect a personal computer or operator interface.
- As a network interface to a **DirectNET** network.

The following pages provide an overview of these uses, along with the information you need to connect the DCU.

How can I use the DCU?

As a General Purpose Communication Port

As a communication port, you can connect various devices, such as operator interfaces or personal computers.

Since the DCU does not require any programming, you can simply set the DCU communication parameters, connect the appropriate RS232C or RS422 cables, and start programming or transferring data.

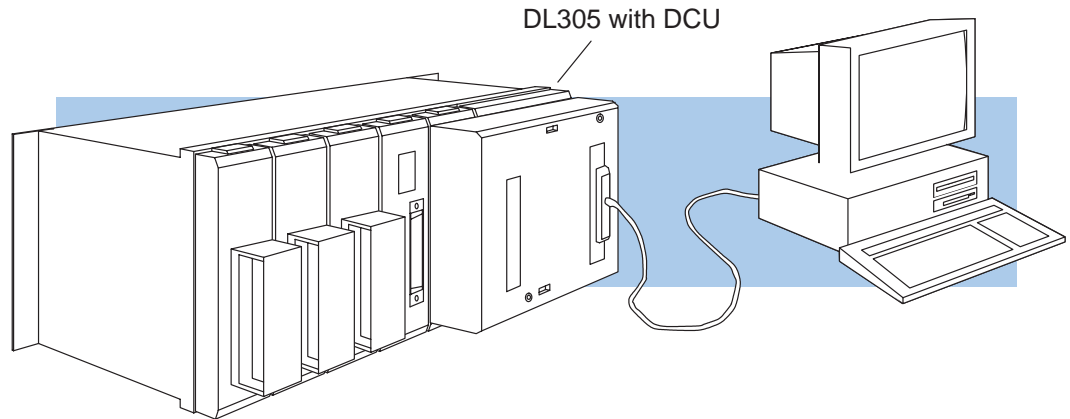

As a *DirectNET* Interface

The DCU can be used as a network interface for applications that require data to be shared between PLCs, or between PLCs and an intelligent device (such as a host computer). The DCU easily connects to *DirectNET*. This network allows you to upload or download virtually any type of system data including Timer/Counter data, I/O information, and Register memory information.

As part of a PLC Network Slave — The DCU can only be used in a DL305 PLC station that is serving as a network slave station. In this case, the DCU “listens” to the network for any messages that contain the DCU’s address. The DCU deciphers the network commands, carries out the request to read or write data, and sends confirmation and/or information to the master station.

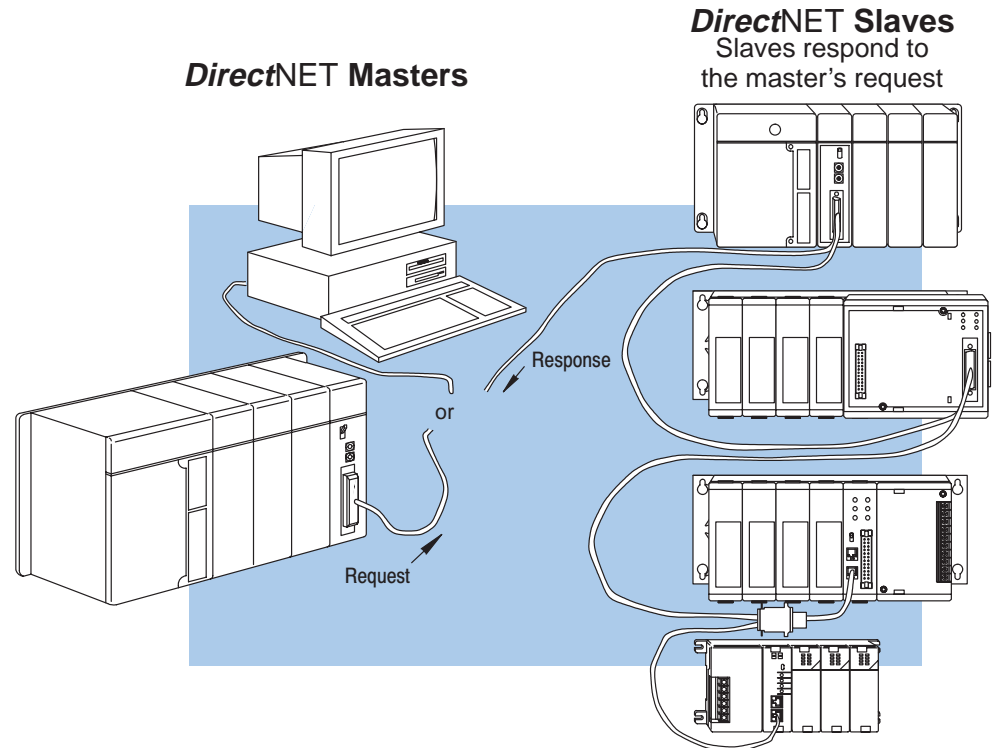

How can I connect the DCU? – Four Simple Steps

Complete the following steps to connect the DCU.

STEP 1. Build the communication cable that fits your needs.

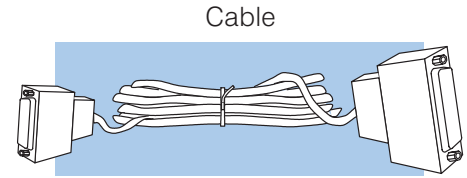

STEP 2. Set the DCU switches. (Baud rate, parity, etc.)

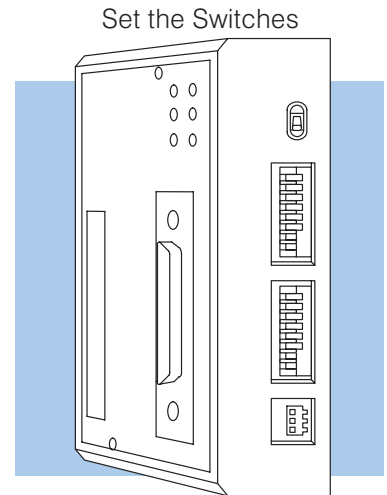

STEP 3. Install the DCU.

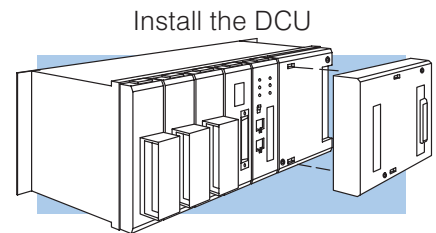

STEP 4. Verify correct operation.

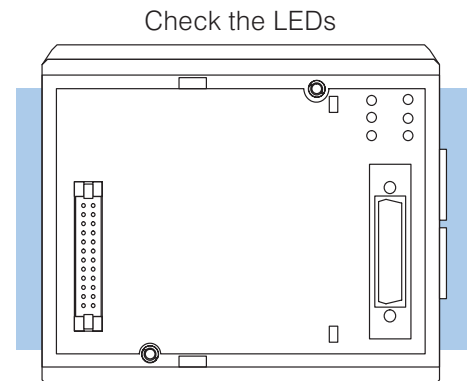

Step 1: Build the communication cable

Things to Consider There are several considerations that help determine the type of cable needed for your DCU application.

1. Will the DCU be physically connected in a point-to-point configuration or multi-drop configuration?
2. What electrical specification is best for your application? RS232C or RS422?
3. What is the cable schematic?
4. What are the relevant cable specifications?
5. What installation guidelines are necessary?
6. Do you just need a quick test cable?

The next few pages discuss these considerations in detail. If you already know the type of cable that is needed, the cable schematics are included on pages 8 and 9.

**Consideration 1:
Physical
Configuration**

Depending on the version of DCU you have, you can use the DCU in either a point-to-point or multi-drop configuration. A point-to-point connection only has two stations, a master and a slave. Use the point-to-point configuration to connect a personal computer, an operator interface, or an intelligent device to a single DCU. You should also use this configuration when you want to connect a **DirectNET** master station to a single **DirectNET** slave station.

Use the multi-drop configuration to connect one master to two or more slaves.

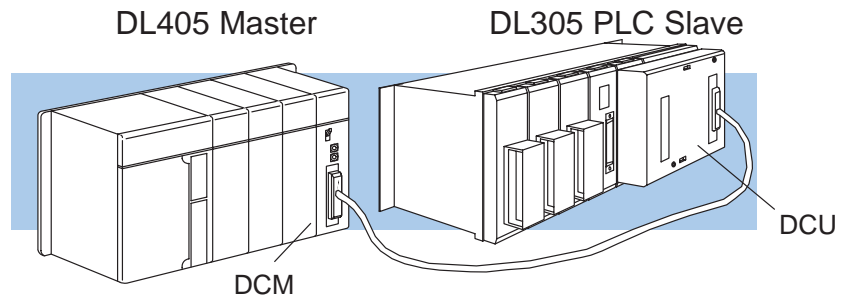
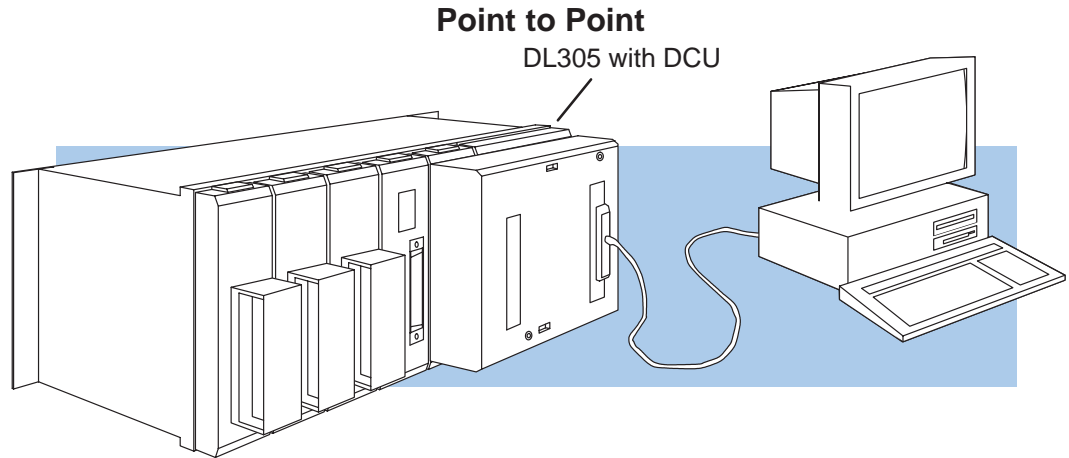

**Consideration 2:
Electrical
Specification
RS232C or RS422**

There is a specific model of DCU for both RS232C and RS422 communication. Your application and configuration choice will help determine which electrical specification is best for you. If you are using multi-drop, you should use RS422. (You can use RS232C/RS422 converters if necessary.) If you are using point-to-point, you may have a choice between RS232C and RS422.

You can use RS232C if the cable length is less than 50 feet and if the cable will not be subjected to induced electrical noise that is commonly found near welders, large motors, or other devices that create large magnetic fields.

You should use RS422 for all other applications. RS422 allows longer cable distances (up to 3300 feet) and provides higher noise immunity.

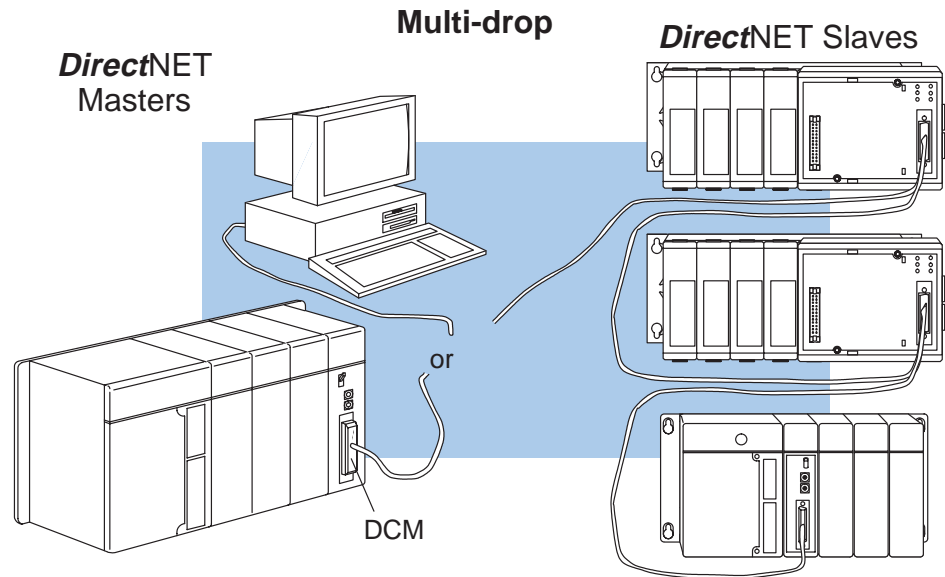

The following diagram shows the port pinouts for the two types of DCUs.

D3-232-DCU Port Pinouts

D3-422-DCU Port Pinouts

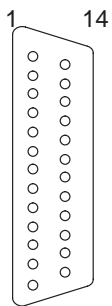

Pin	Signal Definition	Pin	Signal Definition	Pin	Signal Definition	Pin	Signal Definition
1	Not connected	14	Not connected	1	Not connected	14	RS422 data out +
2	RS232C TXD	15	Not connected	2	Not connected	15	RS422 data out -
3	RS232C RXD	16	Not connected	3	Not connected	16	RS422 data in -
4	RS232C RTS	17	Not connected	4	Not connected	17	RS422 data in +
5	RS232C CTS	18	Not connected	5	Not connected	18	Not connected
6	Not connected	19	Not connected	6	Not connected	19	Not connected
7	Logic ground 0v	20	Not connected	7	Logic ground 0V	20	Not connected
8	Not connected	21	Not connected	8	Not connected	21	Not connected
9	Not connected	22	Not connected	9	Not connected	22	RS422 data out +
10	Not connected	23	Not connected	10	RS422 RTS +	23	RS422 data out -
11	Not connected	24	Not connected	11	RS422 RTS -	24	RS422 data in -
12	Not connected	25	Not connected	12	RS422 CTS +	25	RS422 data in +
13	Not connected			13	RS422 CTS -		

Consideration 3: Cable Schematics The following cable schematics are appropriate for most applications. You may have to combine some of these examples to design a cable that meets your exact application requirements.

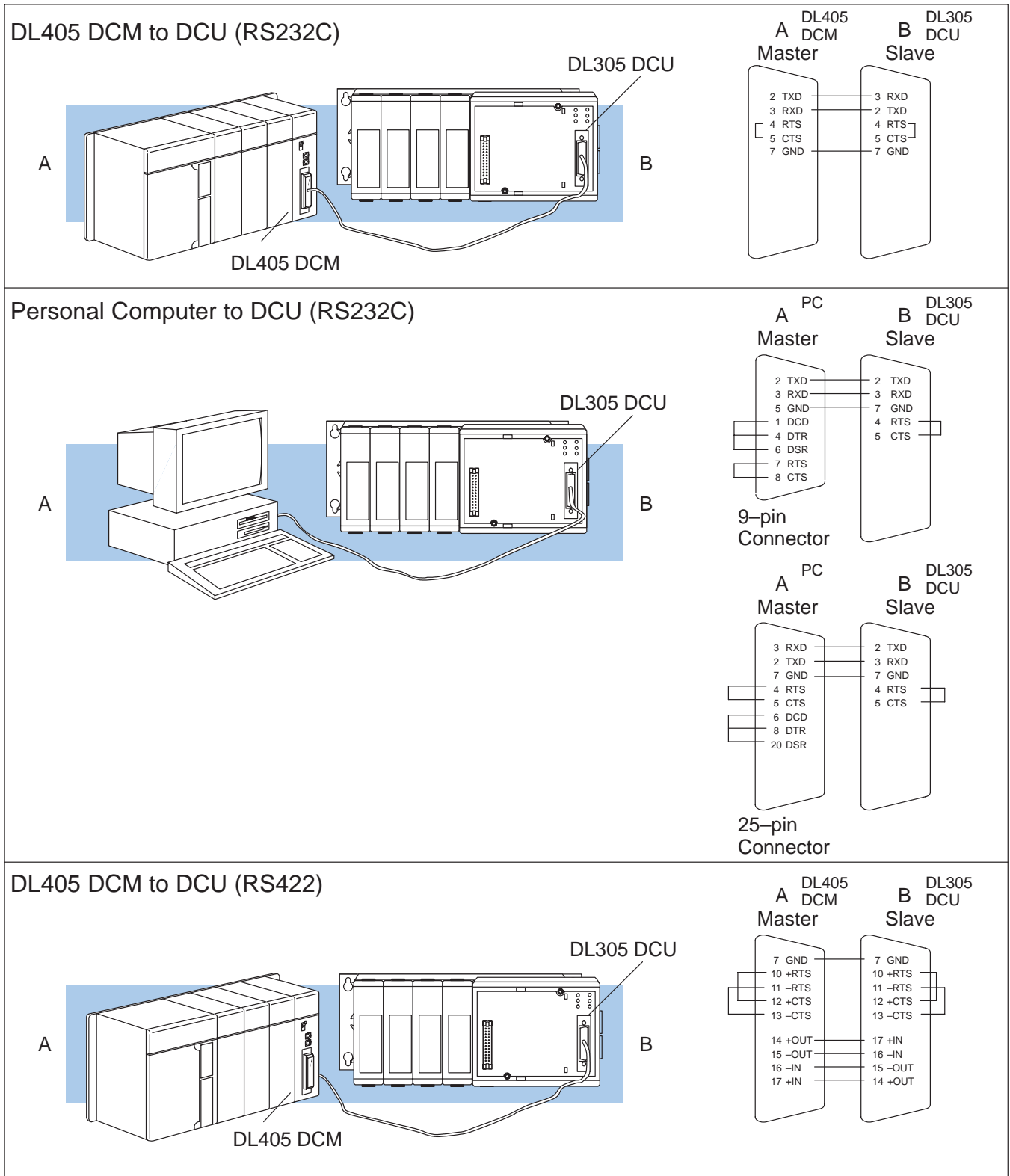

Multi-drop, DL405 DCM to DL305DCU and DL405PLC Slaves (RS422)

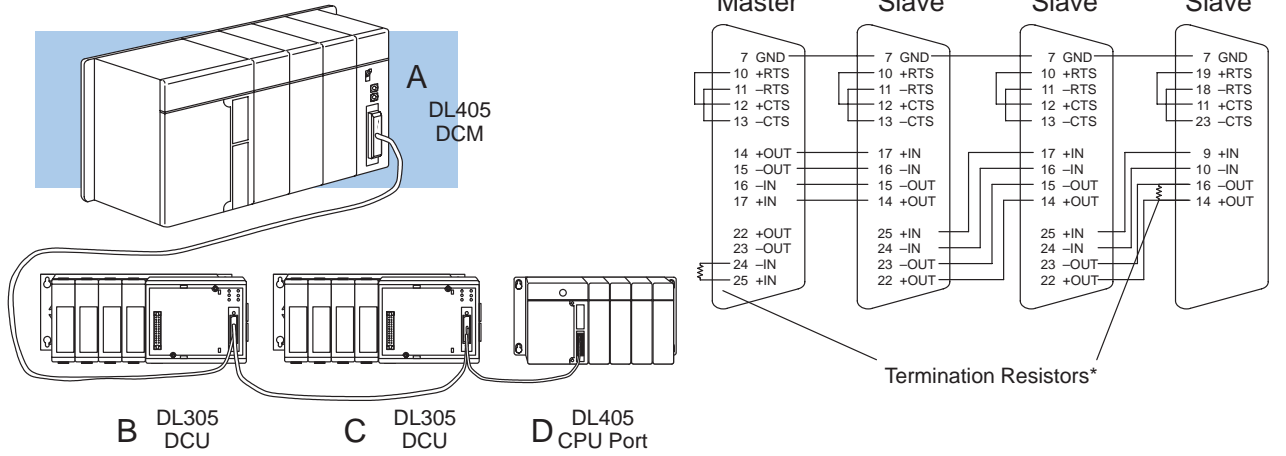

Multi-drop, PC to DL305DCU and DL405PLC Slaves (RS422)

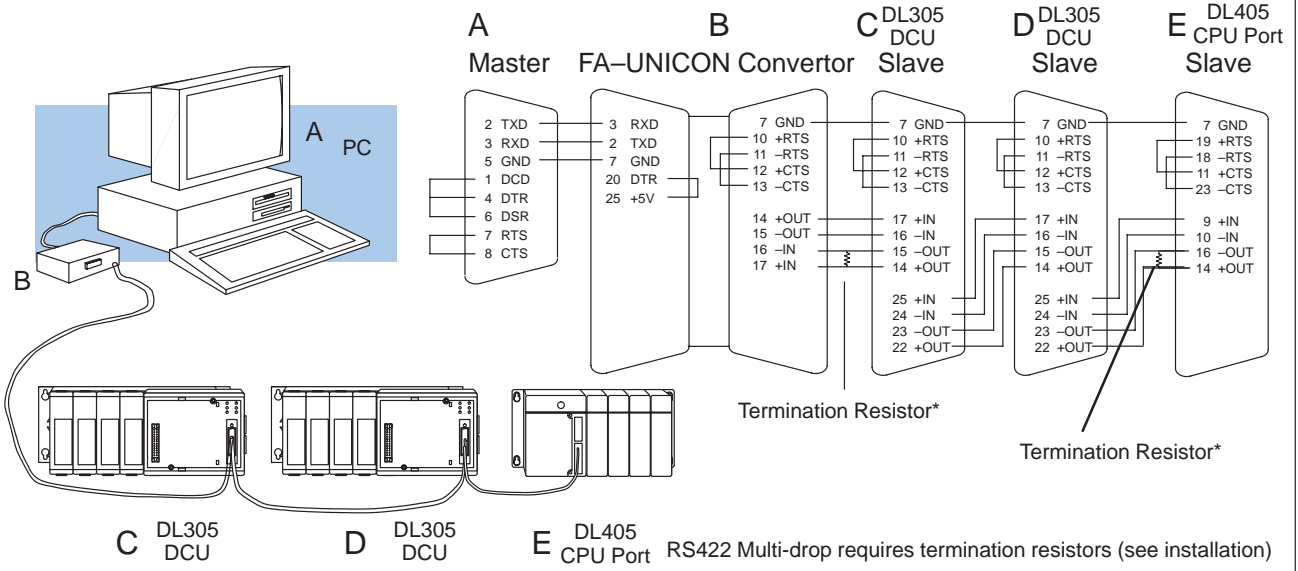

Consideration 4: Cable Specifications

Although many types of cables may work for your application, we recommend you use a cable that is constructed to offer a high degree of noise immunity. A cable constructed equivalent to Belden 9855 should be sufficient. The following specifications should be used as a guideline.

Structure	Shielded, twisted-pair (RS232C only uses two wires and a ground)
Conductor size	24 AWG or larger
Insulation	Polyethylene
Shield	Copper braid or aluminum foil
Impedance	100 Ω @ 1MHz
Capacitance	60pf / meter or less

Consideration 5: Installation Guidelines

Your company may have guidelines for cable installation. If so, you should check those before you begin the installation. Here are some general things to consider.

- Don't run cable next to larger motors, high current switches, or transformers. This may cause noise problems.
- Route the cable through an approved cable housing to minimize the risk of accidental cable damage. Check local and national codes to choose the correct method for your application.
- Consider redundant cabling if the application data is critical. This allows you to quickly reconnect all stations while the primary cable is being repaired.

Cable Shield Grounding — It is important to ground the cable shield to minimize the possibility of noise. The preferred method is to connect one end (preferably the receiver end) of the cable shield to the connector housing. If noise problems are still present and you have a good earth ground for the cabinet, you should connect one end of the shield to the cabinet earth ground. *Don't* ground both ends of the shield because this will create induced noise on the cable.

Step 1: Strip back about 2.5" of the shield.

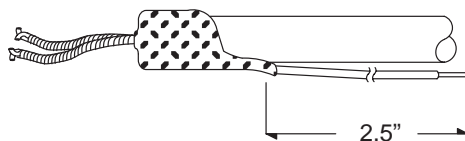

Step 2: Crimp a ring connector onto the shield.

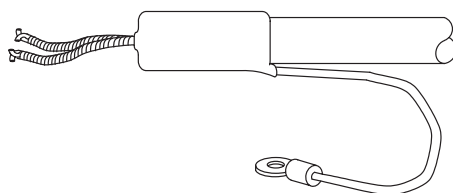

Step 3: Secure the shield to the connector shell.

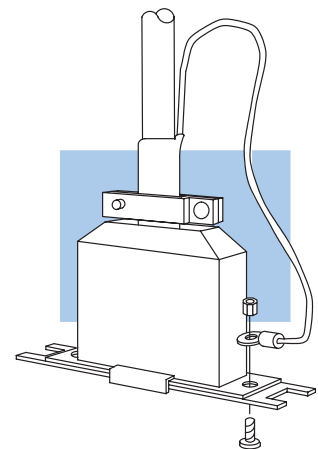

Multi-drop Termination Resistors — It is important you add termination resistors at each end of the RS422 line. This helps reduce data errors during data transmission. You should select resistors that match the cable impedance. For example, a typical 22 AWG solid conductor cable with 4.5 twists per foot has a typical impedance of about 120Ω.

There are two ways to actually connect the resistors.

- Line-to-Line — this method balances the receive data lines (IN+ and IN-) and requires one resistor at each end of the line. (The cable diagrams we've provided show this method, but you can use either.)
- Line-to-Ground — this method also balances the receive data lines, but common mode noise rejection is improved significantly. This method requires two resistors at each end of the line. Also, since there are two resistors, the sum total of both resistors should match the cable impedance.

The following diagram illustrates the two options.

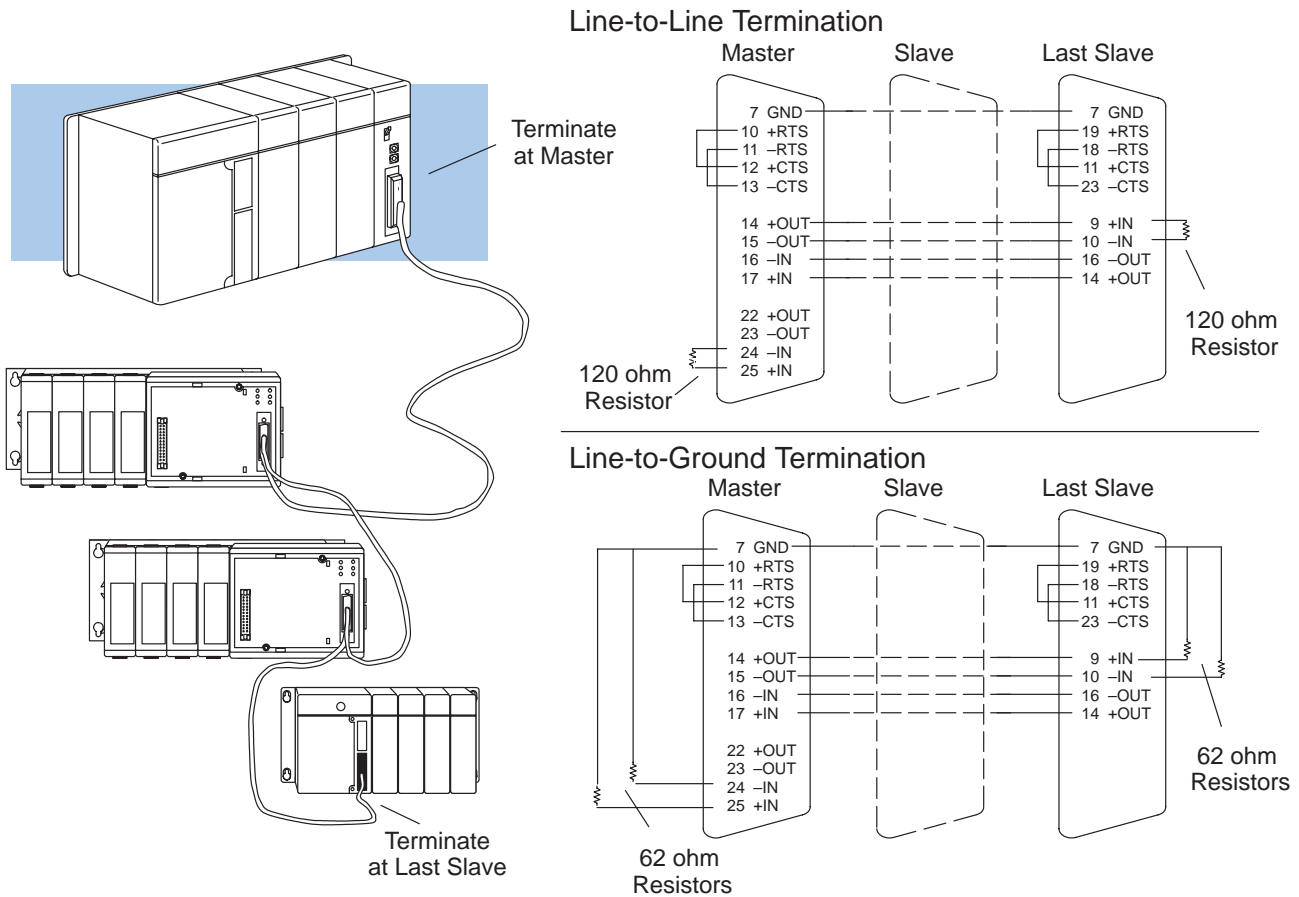

**Consideration 6:
A Quick Test Cable**

PLC*Direct*™ offers a Universal Cable Kit (part number FA-CABKIT). This cable kit allows you to connect various types of *Direct*LOGIC™ products with an RS232C cable in a matter of minutes. The kit consists cable (phone cable with male plugs already attached) and several specially wired connectors. The special connectors are a D-sub style with built-in female phone jacks. The kit includes a wide variety of the special connectors so you can use one kit to easily connect products from the different *Direct*LOGIC™ family of products. To use the kit with the DCU, just follow these steps.

1. Plug the appropriate D-sub connector onto the DCU.
2. Plug the appropriate D-sub connector onto the other device you are connecting to the DCU.
3. Connect the 50 foot cable to the two D-sub connectors.

WARNING: This cable is suitable for quick testing situations and should not be used in actual applications. This cable is not shielded and is highly susceptible to electrical noise. Electrical noise can cause unpredictable operation that may result in a risk of personal injury or damage to equipment. Use the cable specifications described earlier in this manual to select a cable suitable for actual applications.

Build A Test Cable In 30 Seconds

1. Attach Universal Cable Adapter to the DCU
2. Attach another Universal Cable Adapter to the Device which will connect to the DCU
3. Attach the Universal Cable

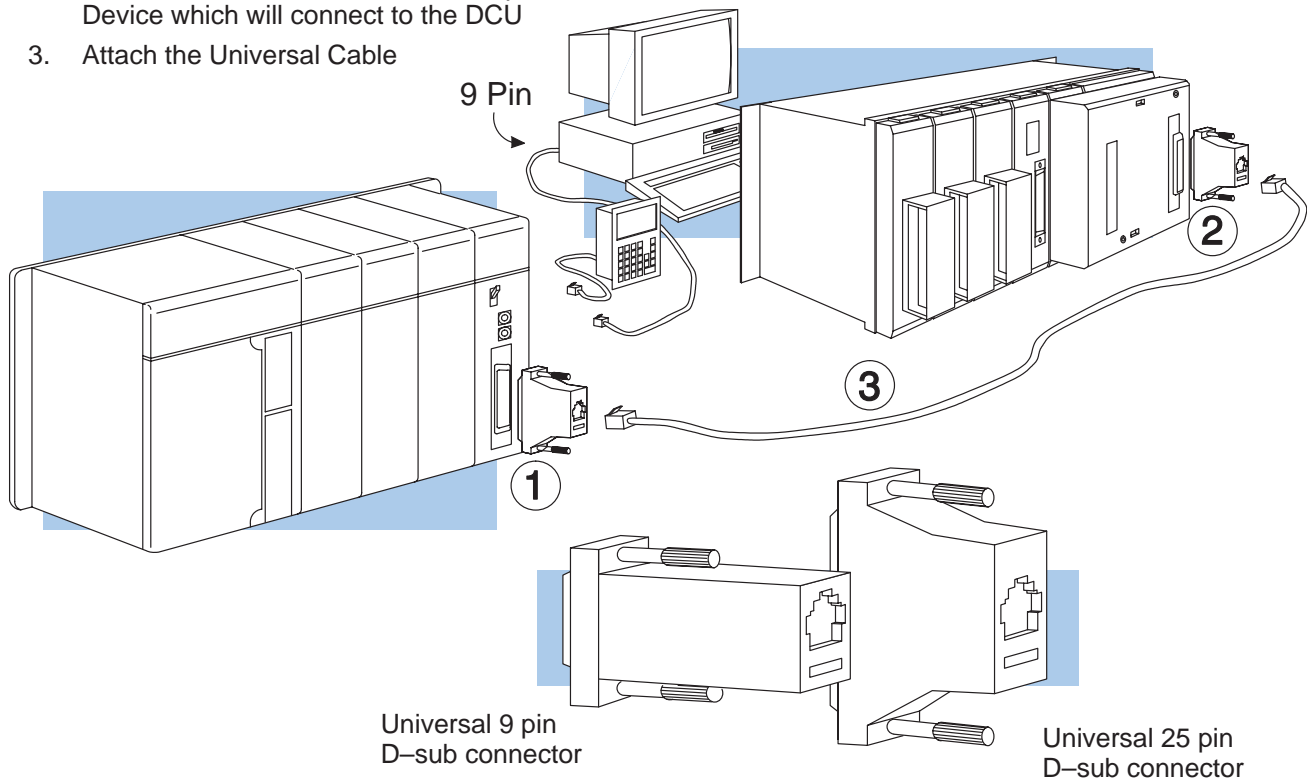

Step 2: Set the DCU switches

The device(s) connected to the DCU will help you determine the appropriate switch settings.

Host Computer or Operator Interface Connection

If you're connecting the DCU to a computer or operator interface, just set the DCU to match those communication parameters. Check the documentation that came with your computer or operator interface to determine the available communication parameters.

You'll need to know the following things.

- Baud rate
- Parity settings
- Protocol

NOTE: Some operator interfaces support multiple protocols. Make sure your operator interface uses one of the following protocols.

- **DirectNET** (DL330, DL340, D3-232-DCU, or D3-422-DCU)
 - Hostlink (TI™ or Simatic® TI325, -330, -335, 305-03DM, or 305-02DM)
-

DirectNET Interface Connection

The DCU can only be used as a slave station, so set the switches to match the communications parameters for the master station.

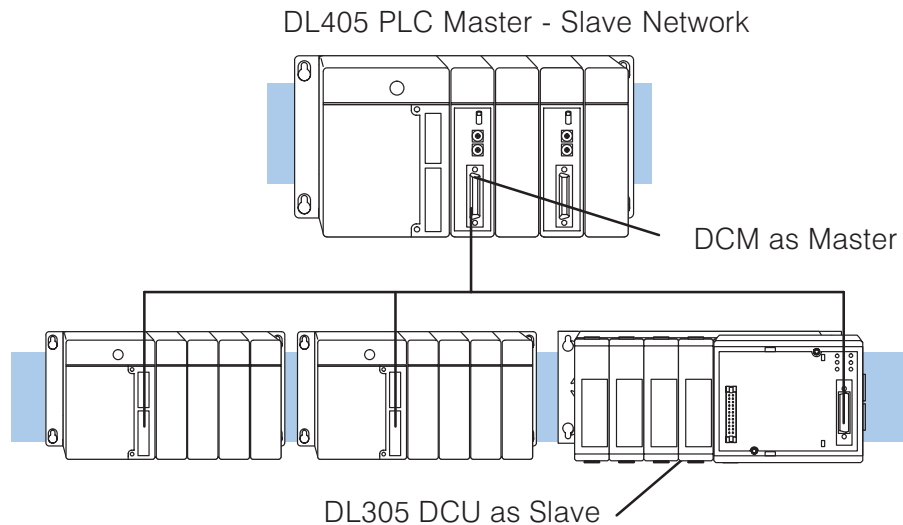

DCU Switch Settings

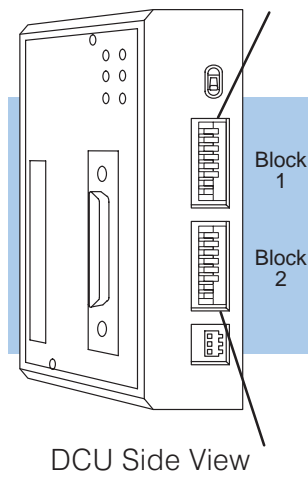

There are two banks of switches located on the side of the DCU that are used to set the communications and protocol parameters. The following diagram shows the locations and setting options.

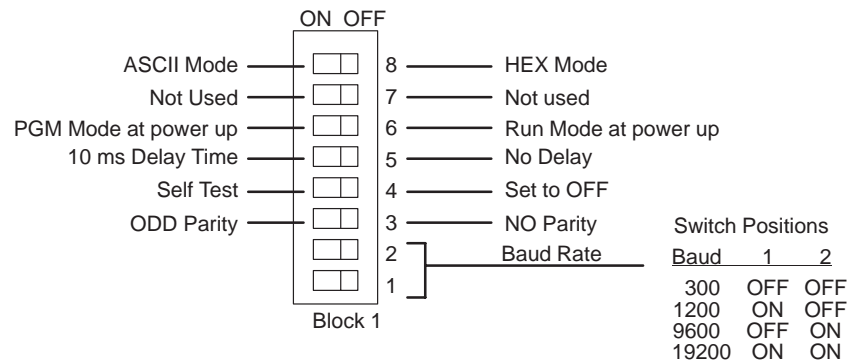

Baud Rate: The first two positions on block 1 are used to set the baud rate for the DCU. There are four baud rate selections available ranging from 300bps to 19.2Kbps. All stations must have the same baud rate before the communications will operate correctly. Usually, you should use the highest baud rate possible unless noise problems appear. If noise problems appear, try reducing the baud rates.

Parity: Position 3 on block 1 selects between the two parity options, odd or none. If you're using all *DirectLOGIC™* equipment, you can use odd parity. Odd parity uses eleven bits total (1 start bit, 8 data bits, 1 stop bit, and 1 parity bit.) Some devices require no parity, which uses only 10 bits (1 start bit, 8 data bits, and 1 stop bit.)

Self-Test: Position 4 on block 1 selects the factory self-test and should always be switched off. If the self-test is on, the DCU will not operate correctly.

Response Delay Time: Position 5 on block 1 sets the response delay time. This sets how long the DCU will wait before it responds to each component of a *DirectNET* communication request. If you're using all *DirectLOGIC™* equipment, a response delay is not required and you should turn off the switch.

The DCU may respond too quickly for some devices, such as telephone or radio modems. If you encounter this problem, turn on the delay switch to provide a 10 ms delay. If this still does not work, check your device manual to see if the device requires more than a 10 ms delay.

Mode at Power-up: Position 6 on block 1 allows you to select the CPU operating mode when system power is supplied. If the switch is turned on, the CPU automatically enters Program mode when power is supplied. If the switch is off, the CPU automatically enters Run mode when power is supplied.

ASCII / HEX Mode: Position 8 on block 1 selects between ASCII and HEX modes of data representation. If you want the fastest communication possible, use HEX mode. The difference is in the way the data is represented. The same data is twice as long in ASCII format, so if there's more data, it takes longer to transfer. If you have a device on the network that requires ASCII mode, then set the switch for ASCII mode, otherwise, use HEX mode.

Online / Offline Switch

As you examined the diagrams at the beginning of this manual you may have noticed you can still connect a Handheld Programmer even when there is a cable connected to the DCU. There's an Online/Offline switch on the side of the unit that determines which connection has control of the CPU.

In the Offline position, this switch logically disconnects the DCU from the network (just as if you pulled the cable from the 25-pin connector.) Once this switch is moved to the Offline position, the DCU will not communicate with the network, and the Handheld Programmer can communicate with the CPU.

If you move the switch to the Online position, the DCU will communicate with the network, but not until the master sends a request for communication. This does not operate like the reset switch on many personal computers.

NOTE: You cannot use the Handheld Programmer if the switch is in the Online position.

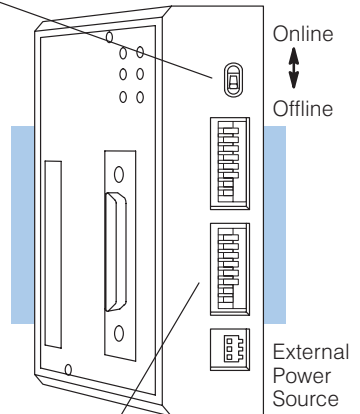

Address Switch

The DCU station address is set by the second switch block, which is located on the side of the unit. The decimal address is set in BCD (Binary Coded Decimal) format with valid addresses from 1 to 90 decimal. For example, to set an address of 10, you should turn on switches 4 and 2.

The addresses do not have to be sequential, but each station must have a unique address.

NOTE: The DCU address switch settings are only read at power up. If you've want to change the address and the DCU is already up and running, you'll have to cycle the system power to initialize the change.

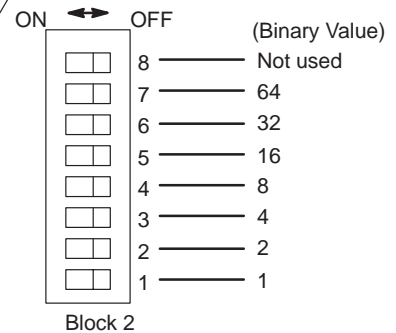

Step 3: Install the DCU and start the communications

Check the Power Budget

The DCU requires 500 mA of +5V base power. Make sure you will not exceed the available base power budget by installing the DCU.

WARNING: Exceeding the base power budget may cause unpredictable system operation that can result in personal injury or equipment damage. See the DL305 User Manual for details on power budget calculations.

On the back of the DCU is a switch to select if it will receive power from the base (INT – internal position) or from an external power source (EXT – external position). If there appears to be a power budget problem, use the external power source option. The DCU is shipped with a three pin pigtail which should be used to connect the external power source. The pigtail connects to the bottom outlet on the side of the DCU.

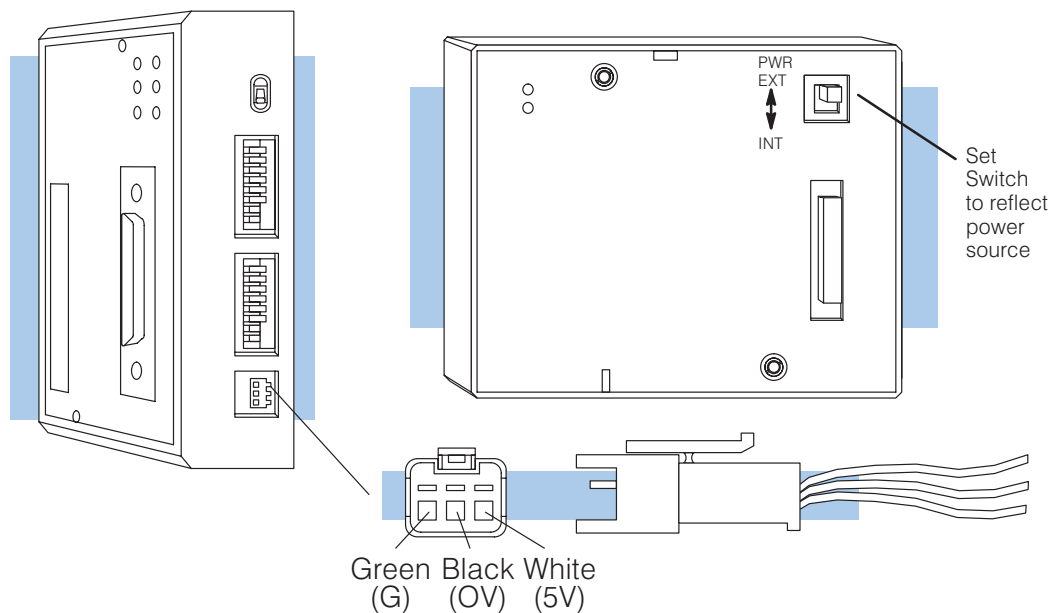

If you use an external power supply, you must provide an external ground connection for the DCU. The following diagram shows how the external power sources are connected.

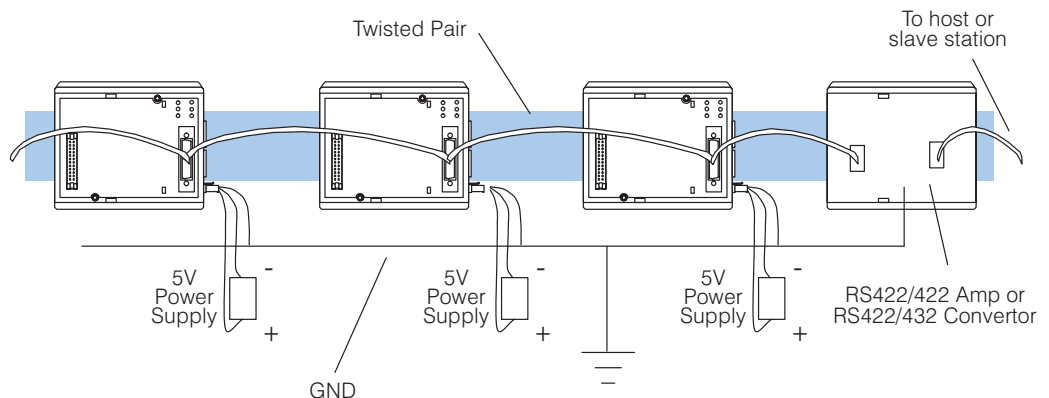

Install the DCU

Use the following procedures to install the DCU.

WARNING: Always disconnect the system power before installing or removing any system component. Also, *do not* install a DCU while the CPU is in RUN mode. This may cause unpredictable operation which can result in a risk of of electrical shock, personal injury, or equipment damage.

1. Set the power source switch, located on the rear of the DCU, to the correct position.
2. Carefully align the connector on the rear of the DCU with the CPU connector and gently push the DCU onto the CPU. (If the connectors are not aligned properly, you can bend the connector pins.)
3. Secure the DCU to the system with the two mounting screws.

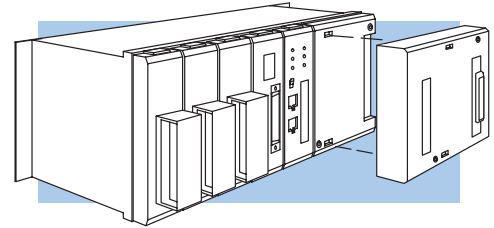

Connect the Cables

Make sure you have all the cables connected and that all the network devices have the same communication parameters (baud rate, parity, etc.)

If you're using an Operator Interface or Computer...

Connect the cables and follow the procedures outlined in the documentation that came with your host computer software or operator interface. You'll have to execute your host or operator interface program before the communications can begin. For example, if you're using *DirectSOFT*, you can just specify the station address and start working!

If you're using DirectNET...

Since you can only use the DCU in a slave station, there has to be a network master that issues the communication requests. The PLC master station must contain an RLL communications program . (See the *DirectNET* Manual or the DL405 User Manual for details on the RX and WX instructions.) The master station CPU must be in Run mode in order to execute the communications program. The slave station CPUs do not absolutely have to be in Run mode because the DCU will still transfer the data. Whether you put the slave stations in Run mode depends on your application requirements.

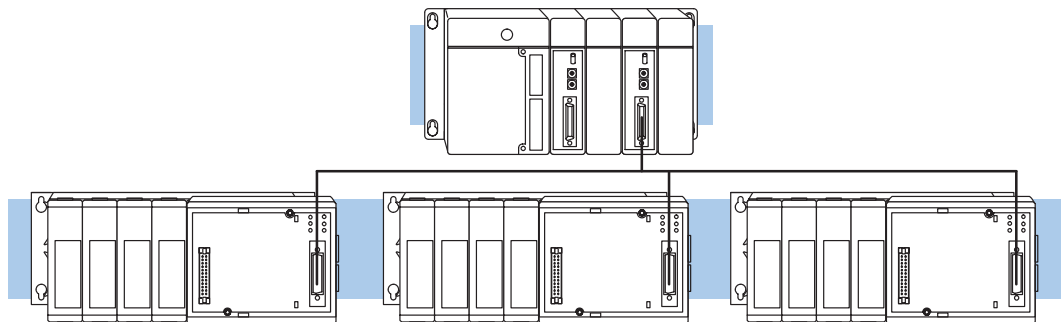

Step 4: Verify that it's working correctly

Check the DCU indicators to verify the DCU is operating correctly. The following diagram shows the proper indicator conditions.

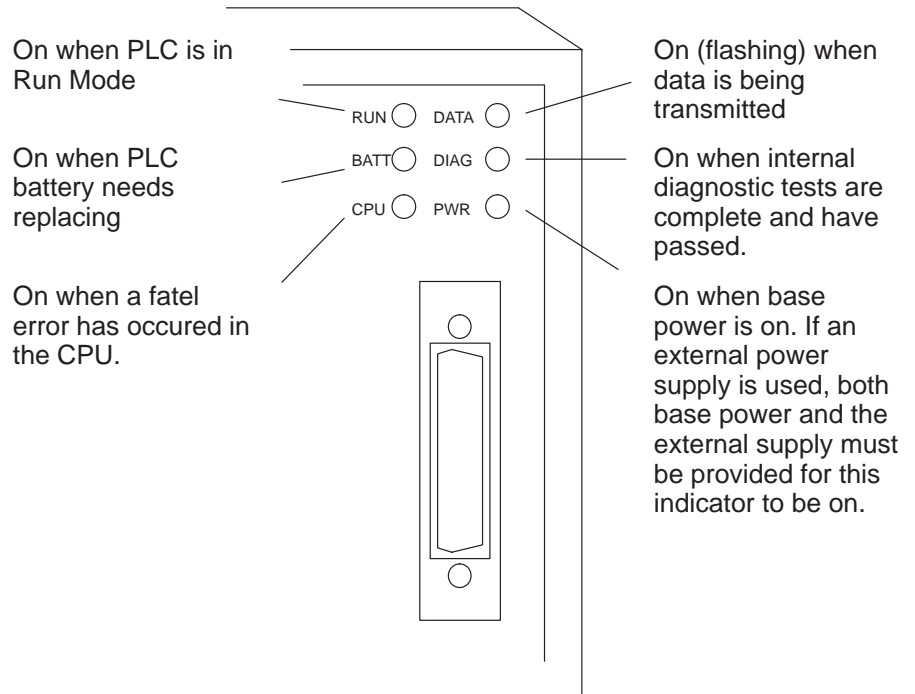

Troubleshooting

If the DCU does not seem to be working correctly, check the following items.

1. Cable and connections. Incorrectly wired cables and loose connectors cause the majority of problems. Verify you've selected the proper cable configuration and check to see the cable is wired correctly.
2. Dipswitch settings. Make sure you've set the DCU to match the communication parameters required by the master station (DL405 DCM, operator interface or host computer).
3. Incorrect protocol. Make sure your operator interface or personal computer software can use the **DirectNET**, Hostlink/CCM2 protocol.
4. Communications program. Check the communications program for errors. Consult the **DirectNET** Manual or the manuals that came with your host computer software or operator interface for details.

The following table provides additional troubleshooting details.

Indicator Status	Possible Cause	Corrective Action
PWR off	PLC power is disconnected DCU is not connected to the CPU properly DCU external power source (if used) is not connected DCU is defective	Check the PLC source power. Make sure the DCU is securely fastened to the CPU and no connector pins are bent. Check the external power source. Replace the DCU
DIAG off	DCU is defective	Replace the DCU
DATA does not flash during communications	Loose or incorrectly wired cable Online / Offline switch is in the Offline position Communications program is not correct	Check the cable connections and pinouts. Set the switch to Online. Check the master communications program. Verify the address, amount of data, and data type are correct.

Specifications

Environmental Specifications

Operating Temperature	32 to 140 F° (0 to 60 C°)
Storage Temperature	–4 to 158 F° (–20 to 70 C°)
Operating Humidity	5 to 95% (non-condensing)
Air Composition	No corrosive gases permitted
Vibration	MIL STD 810C 514.2
Shock	MIL STD 810C 516.2
Voltage Isolation	1500 VAC, 1 minute duration
Noise	NEMA ICS3–304

Operating Specifications

Power Budget Requirement	500 ma @ 5 V
Communication Interface	
D3–232–DCU	Serial RS232C, half-duplex, DTE, Asynchronous, 8 bits/character
D3–422–DCU	Serial RS422, Half-duplex, Asynchronous, 8 bits/character
Baud Rates	300 to 19.2K baud, switch selectable
Maximum Distance	3300 feet (1000 meters) RS422 50 feet (18 meters) RS232C
Protocol	DirectNET , also compatible with Hostlink/CCM2
Diagnostics	Automatic check of communications, switch settings, and LEDs