

I/O Addressing Conventional Method

In This Appendix. . . .

- Understanding Conventional I/O Numbering
 - Conventional Base Specifications
 - Local and Expansion I/O Systems
 - Setting the Base Switches
 - Example I/O Configurations
-

Understanding Conventional I/O Numbering

This Appendix covers the information needed when installing a DL350 CPU in an conventional base or when the DL350 is in a new base in a mixed system. Since the DL350 can be used in either scenario, both 16 bit and 8 bit addressing needs to be addressed. Chapter 4 provides the information on the xxxx-1 bases and the 16 bit addressing scheme. The DL350 CPU will revert to the DL340 CPU I/O scheme when it is configured for either of these scenarios.

DL305 I/O Configuration History

The conventional DL305 product family has had several enhancements over the years. Each time the product family has grown or has been enhanced, compatibility with the earlier products has been of the utmost concern. Some of these enhancements such as increasing the I/O count and supporting 16 point modules have impacted the numbering system. To help you understand the numbering scheme, the following account of how the numbering system has been affected is provided.

- When the 16 point I/O modules were introduced to the standard line of 8 point modules, the I/O numbering system was not modified to count in 16 consecutive units. This was done to maintain compatibility with the 8 point systems. This means each 16 point module uses two groups of eight consecutive numbers such as 000 through 007 and 100 through 107.
- When the I/O count was increased from the original 112 maximum to 176 maximum (DL330/DL330P CPU) to 184 maximum (DL340/DL350 CPU), most of the new I/O addresses were not set up to be consecutive with the the original 112 I/O. This means you will see a large jump in the I/O number ranges.

Octal Numbering System

The conventional DL305 I/O points are numbered in octal (base 8.) The octal numbering system does not include the numbers 8 and 9. The following table lists the first few octal numbers with the equivalent decimal numbers so you can see the numbering pattern.

Octal Numbers	0	1	2	3	4	5	6	7	10	11	12	13	14	15	16	17	20	21	22	23	24	...
Decimal Numbers	0	1	2	3	4	5	6	7	8	9	10	11	12	13	14	15	16	17	18	19	20	...

Fixed I/O Numbering

The DL305 base I/O numbering is fixed, you cannot choose the I/O address of specific points since the system allocates the addresses for each slot. The I/O number ranges are 0-177 and 700-767. The I/O numbering for each slot in the base depends on two things:

1. The base configuration, which is determined by the size of the base and whether you are using an expansion base.
2. The number of I/O points per module and the location of the I/O modules in the base.

I/O Numbering Guidelines

I/O numbering begins with address “000” which is the slot adjacent to the CPU. Each module uses increments of eight I/O points. For 8 point modules the I/O addresses are made up of eight contiguous points for each module. For 16 point modules the I/O addresses are made up of two groups of eight contiguous points, the first group follows the same scheme as the 8 point module and the second group adds 100 to the values of the first group.

The examples below show the I/O numbering for a 5 slot local CPU base with 8 point I/O and a 5 slot local CPU base with 16 point I/O.

5 Slot Base Using 8 Point I/O Modules

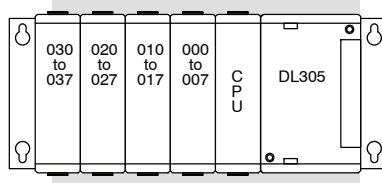

Slot Number: 3—2—1—0

5 Slot Base Using 16 Point I/O Modules

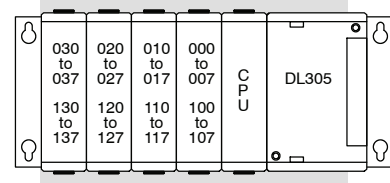

Slot Number: 3—2—1—0

Number of I/O Points Required for Each Module

DC Input Modules		DC Output Modules		Relay Output Modules		Analog Modules (cont.)	
D3-08ND2	8	D3-08TD1	8	D3-08TR	8	F3-04DA-1	16
D3-16ND2-1	16	D3-08TD2	8	F3-08TRS-1	8	F3-04DA-2	16
D3-16ND2-2	16	D3-16TD1-1	16	F3-08TRS-2	8	F3-04DAS	16
D3-16ND2F	16	D3-16TD1-2	16	D3-16TR	16	ASCII BASIC Modules	
F3-16ND3	16	D3-16TD2	16	Analog Modules		F3-AB128-R	16
AC Input Modules		AC Output Modules		D3-04AD	16	F3-AB128-T	16
D3-08NA-1	8	D3-04TAS	8*	F3-04ADS	16	F3-AB128	16
D3-08NA-2	8	F3-08TAS	8	F3-08AD	16	F3-AB64	16
D3-16NA	16	D3-08TA-1	8	F3-08TEMP	16	Specialty Modules	
AC/DC Input Modules		D3-08TA-2	8	F3-08THM-n	16	D3-08SIM	8
D3-08NE3	8	F3-16TA-2	16	F3-16AD	16	D3-HSC	16
D3-16NE3	16	D3-16TA-2	16	D3-02DA	16		

* This is a 4-point module, but each slot is assigned a minimum of 8 I/O points.

**I/O Module
Placement Rules**

There are some limitations that determine where you can place certain types of modules. Some modules require certain locations and may limit the number or placement of other modules. We have tried to give clearly written explanations of the rules governing module placement, but we realize a picture can sometimes be worth a thousand words. If you have difficulty with some of our explanations, please look ahead to the illustrations in this chapter. They should clear up any gray areas in the explanation and you will probably find the configuration you intend to use in your installation.

In all of the configurations mentioned the number of slots from the CPU that are to be used can roll over into an expansion base if necessary. For example if a rule states a module must reside in one of the six slots adjacent to the CPU, and the system configuration is comprised of two 5 slot bases, slots 1 and 2 of the expansion base are valid locations.

The following table provides the general placement rules for the DL305 components.

Module	Restriction
CPU	The CPU must reside in the first slot of the local CPU base. The first slot is the closest slot to the power supply.
16 Point I/O Modules	There can be a maximum of eight 16 point modules installed in a system depending on the CPU type and I/O modules used. The 16 point modules must be in the first 8 slots adjacent to the CPU rolling over into an expansion base if necessary. If any of the eight slots adjacent to the CPU are not used for 16 point modules, they can be used for 8 point modules.
Analog Modules	Analog modules must reside in any valid 16 point I/O slot.
ASCII Basic Modules	ASCII Basic modules must reside in any valid 16 point I/O slot.
High Speed Counter	High Speed Counters may be used in one of the first 4 slots in the local CPU base.

Conventional Base Specifications

The table below provides the specifications for the conventional DL305 bases. The xxxx-1 bases are covered in Chapter 2, Installation, Wiring, and Specifications.

	D3-05B	D3-05BDC	D3-08B	D3-10B
Number of Slots	5	5	8	10
Local CPU Base	Yes	Yes	Yes	Yes
Expansion Base	Yes	Yes	No	Yes
Input Voltage Range	97-132 VAC 194-264 VAC 47-63Hz	20.5-30 VDC <10% ripple	97-132 VAC 194-264 VAC 47-63Hz	97-132 VAC 194-264 VAC 47-63Hz
Base Power Consumption	70 VA max (46W)	48 Watts	70 VA max (57W)	70 VA max (57W)
Inrush Current max.	30A	30A	30A	30A
Dielectric Strength	1500VAC for 1 minute between terminals of AC P/S, Run output, Common, 24VDC	1500VAC for 1 minute between 24VDC input terminals and Run output	1500VAC for 1 minute between terminals of AC P/S, Run output, Common, 24VDC	2000VAC for 1 minute between terminals of AC P/S, Run output, Common, 24VDC
Insulation Resistance	>10M Ω at 500VDC	>10M Ω at 500VDC	>10M Ω at 500VDC	>10M Ω at 500VDC
Power Supply Output (Voltage Ranges and Ripple)	(5VDC) 4.75-5.25V less than 0.1V p-p (9VDC) 8.5-13.5V less than 0.2V p-p (24VDC) 20-28V less than 1.2V p-p	(5VDC) 4.75-5.25V less than 0.1V p-p (9VDC) 8.5-13.5V less than 0.2V p-p (24VDC) 20-28V less than 1.2V p-p	(5VDC) 4.75-5.25V less than 0.1V p-p (9VDC) 8.0-12.0V less than 0.2V p-p (24VDC) 20-28V less than 1.2V p-p	(5VDC) 4.75-5.25V less than 0.1V p-p (9VDC) 8.0-12.0V less than 0.2V p-p (24VDC) 20-28V less than 1.2V p-p
5 VDC current available	1.4A *	1.4A	1.4A @ 122° F (50° C) 1.0A @ 140° F (60° C)	1.4A @ 122° F (50° C) 1.0A @ 140° F (60° C)
9 VDC current available	0.8A *	0.8A	1.7A @ 122° F (50° C) 1.4A @ 140° F (60° C)	1.7A @ 122° F (50° C) 1.4A @ 140° F (60° C)
24 VDC current available	0.5A *	0.5A	0.6A	0.6A
Auxiliary 24 VDC Output	100mA max	None	100mA max	100mA max
Run Relay	250 VAC, 4A (resistive load)	250 VAC, 4A (resistive load)	250 VAC, 4A (resistive load)	250 VAC, 4A (resistive load)
Fuses	2A (250V) User replaceable	4A (250V) User replaceable	2A (250V) User replaceable	2A (250V) User replaceable
Dimensions WxHxD	11.42x4.85x4.41 in. (290x123x112 mm)	11.42x4.85x4.41 in (290x123x112 mm)	15.55x4.85x4.41 in (395x123x112 mm)	18.3x4.85x4.41 in. (465x123x112 mm)
Weight	34 oz. (964g)	34 oz. (964g)	44.2 oz. (1253g)	50.5 oz. (1432g)

* The total current for the D3-05B must not exceed 2.3A.

Auxiliary 24VDC Output at Base Terminal

There is 24 VDC available from the 24 VDC output terminals on all bases except the 5 slot DC version (D3-05BDC). The 24 VDC supply can be used to power external devices or DL305 modules that require external 24 VDC. The power used from the this 24 VDC output reduces the internal system 24 VDC available to the modules by an equal amount.

Power Supply Schematics

The following diagram shows the details of how the DL305 base provides many of the specifications listed on the previous page.

Schematic for D3-05B, D3-08B, D3-10B

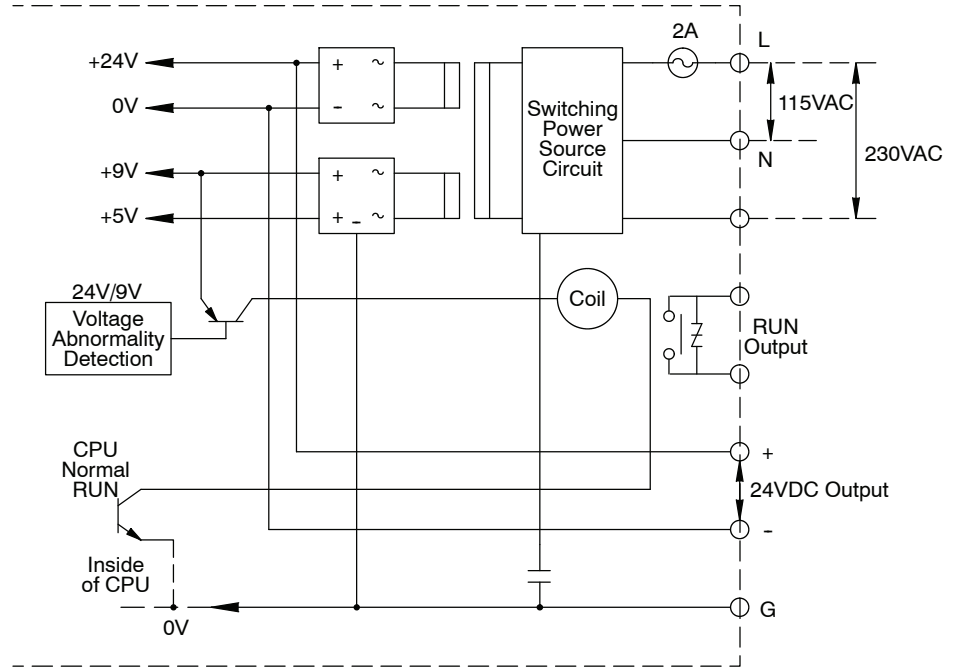

Schematic for D3-05BDC

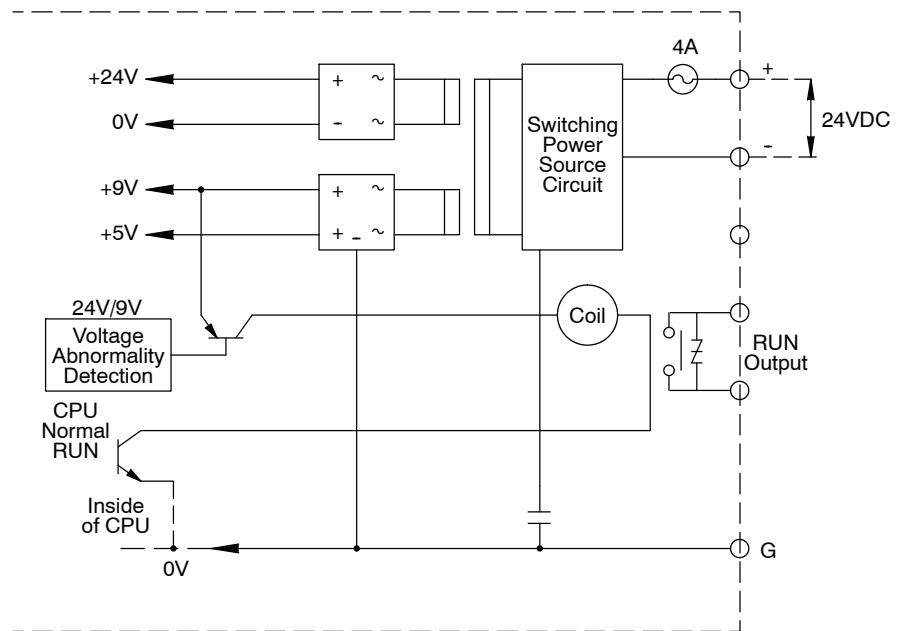

Using the Run Relay on the Base Power Supply

The RUN relay output, located on the DL305 base power supply, can be used to detect an undesired failure on the local CPU base or an expansion base. The following table shows the operating characteristics of the RUN relay for a local CPU base or an expansion base.

Event	Local CPU Base RUN Relay Would:	Expansion Base RUN Relay Would:
PROGRAM to RUN mode Transition	Energize	Not change
The CPU detects a fatal error	De-energize	Not change
CPU Local Base is Removed Form the RUN Mode	De-energize	Not change
Power Source to the Power Supply is Turned OFF	De-energize	De-energize
9 VDC or 24 VDC Failure on the Power Supply	De-energize	De-energize

The following example demonstrates possible uses for the RUN relay on the DL305 bases.

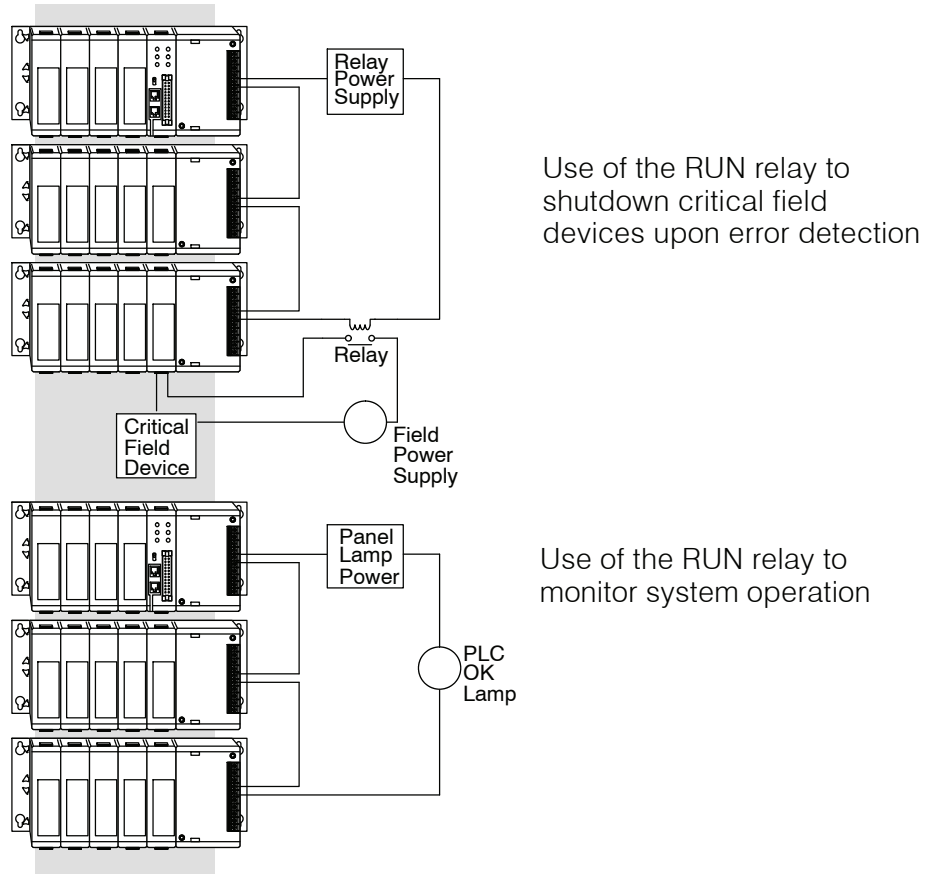

Local or Expansion I/O Systems

Base Uses Table

It is helpful to understand how you can use the various DL305 bases in your control system. The following table shows how the bases can be used.

Base Part #	Number of Slots	Can Be Used As A Local CPU Base	Can Be Used As An Expansion Base
D3-05B	5	Yes	Yes
D3-05BDC	5	Yes	Yes
D3-08B	8	Yes	No
D3-10B	10	Yes	Yes

Local/Expansion Connectivity

The configurations below show the valid combinations of local CPU bases and expansion bases.



NOTE: You should use one of the configurations listed below when designing an expansion system. If you use a configuration not listed below the system will not function properly.

5 slot local CPU base with a maximum of two 5 slot expansion bases

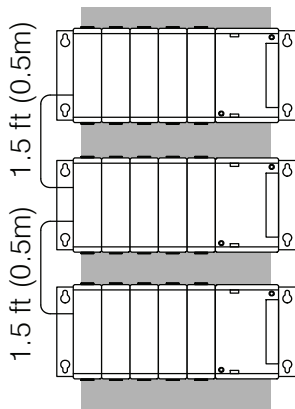

8 slot local CPU base with a 5 slot expansion base

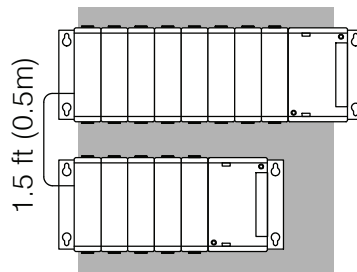

10 slot local CPU base with a 5 slot expansion base

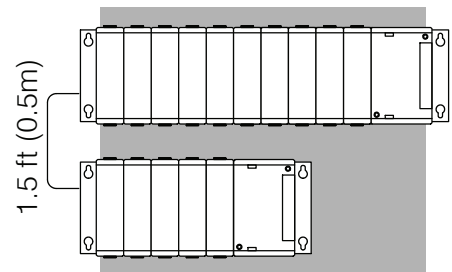

10 slot local CPU base with a 10 slot expansion base

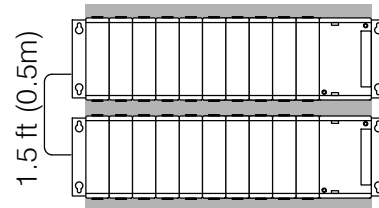

Connecting Expansion Bases

The local CPU base is connected to the expansion base using a 1.5 ft. cable (D3-EXCBL). The base must be connected as shown in the diagram below.

The top expansion connector on the base is the input from a previous base. The bottom expansion connector on the base is the output to an expansion base. The expansion cable is marked with "CPU Side" and "Expansion Side". The "CPU Side" of the cable is connected to the bottom port of the base and the "Expansion Side" of the cable is connected to the top port of the next base.

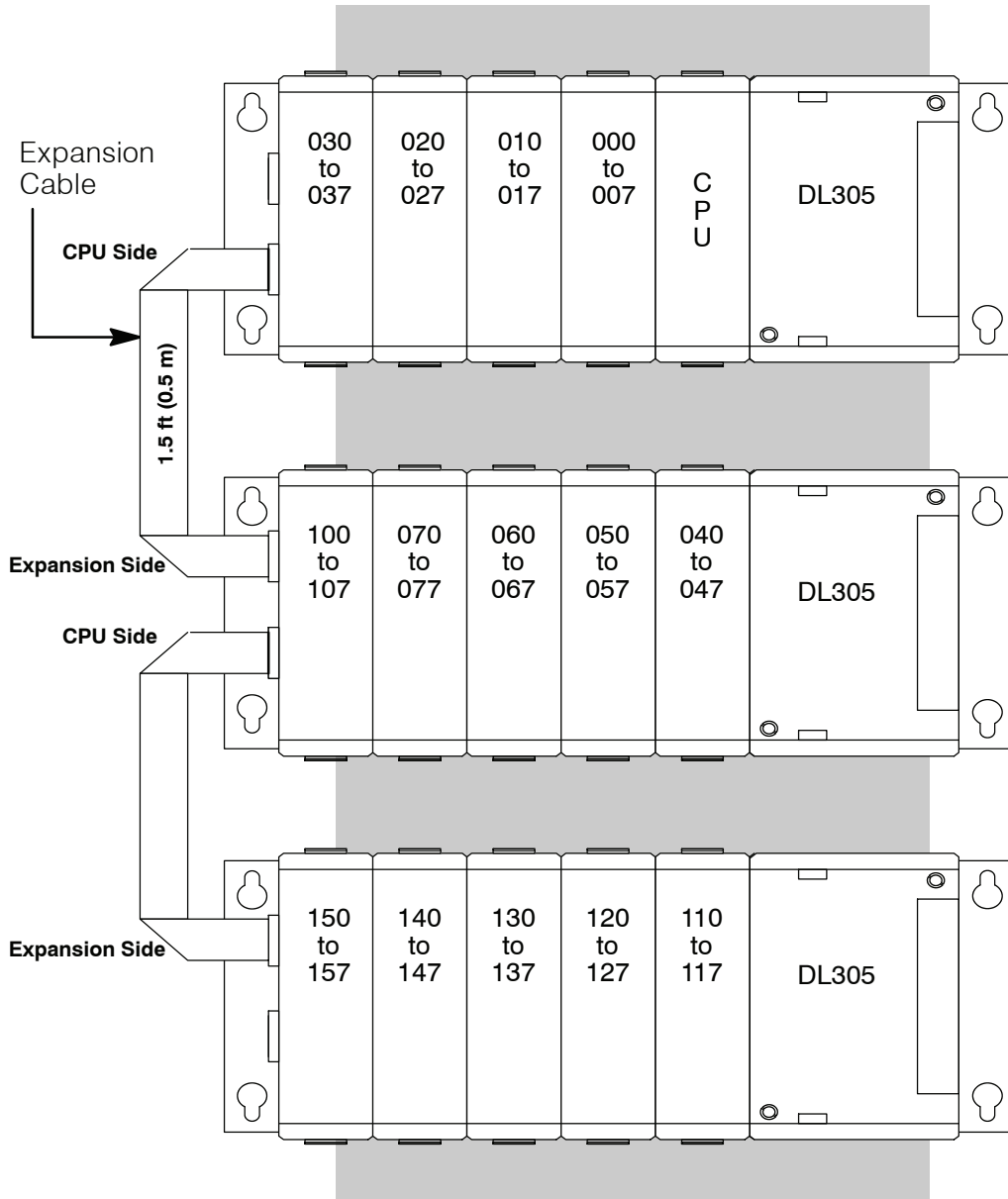

Note: Avoid placing the expansion cable in the same wiring tray as the I/O and power source wiring.

Setting the Base Switches

5 Slot Bases

The conventional 5 slot and 10 slot bases have jumper switches that need to be set depending on which system configuration is used. The 8 slot base does not have any switches. All of the xxxxx-1 bases have a jumper switch and the 10 slot has two.

The conventional 5 slot bases have a two position toggle switch which is used to set the base as the CPU local base, the first expansion base, or the second (last) expansion base. The xxxxx-1 bases have a jumper switch between slots 3 and 4.

The switch is set to the "1,3" position if the base is the local CPU base or the third base in the system. The switch is set to the "2" position if the base is the 2nd base in the system. If the 5 slot base is used as an expansion base for a 10 slot local CPU base the switch is set in the "1,3" position.

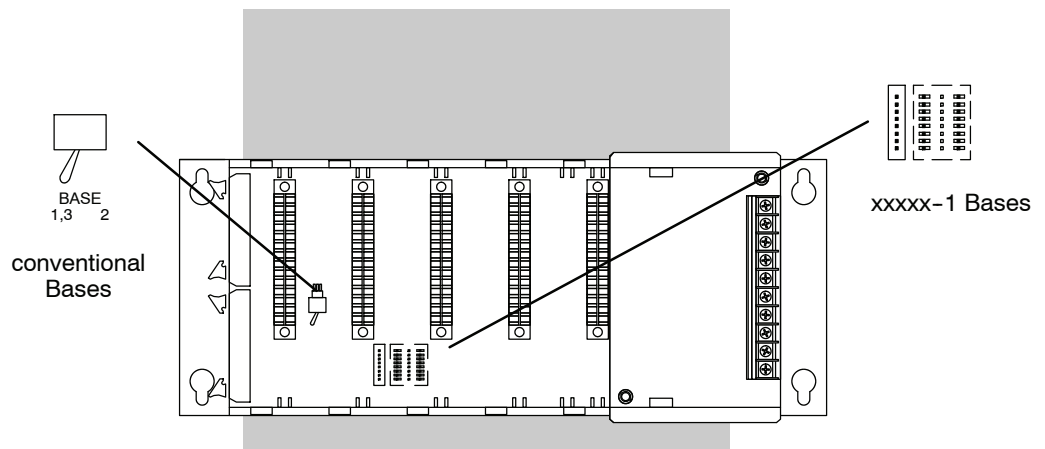

10 Slot Base

The 10 slot base has a jumper switch between slot 3 and 4 used to set the base to local CPU base or expansion base. There is also a jumper switch between slot 9 and 10 (4 and 5 on the xxxxx-1 bases) that sets slot 10 to the 100-107 I/O address range or to the 700-707 I/O address range.

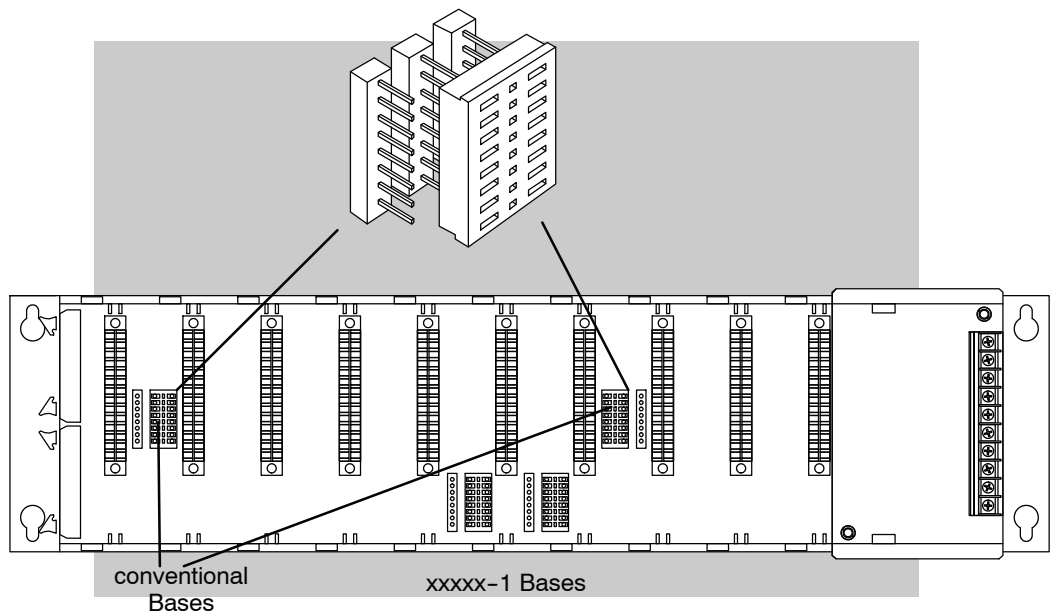

Example I/O Configurations

The following system configurations will allow you to quickly configure your system by using examples. These system configurations show the I/O numbering and the base switch settings for every valid base configuration for a DL305 system.

16 Point I/O Allocation Example

When a 16 point I/O module is used the last 8 I/O addresses of each 16 point module could have been used in another base slot. In the illustration below Example A shows a 16 point module in the slot next to the CPU using address 000-007 and 100-107. The expansion I/O cannot use the last slot of the expansion base since it is assigned addresses 100-107 and the 16 point module next to the CPU has already used these addresses. Example B shows an 8 point module in the slot next to the CPU and an 8 point module in the last slot of the expansion base. Both examples are valid configurations .

Example A

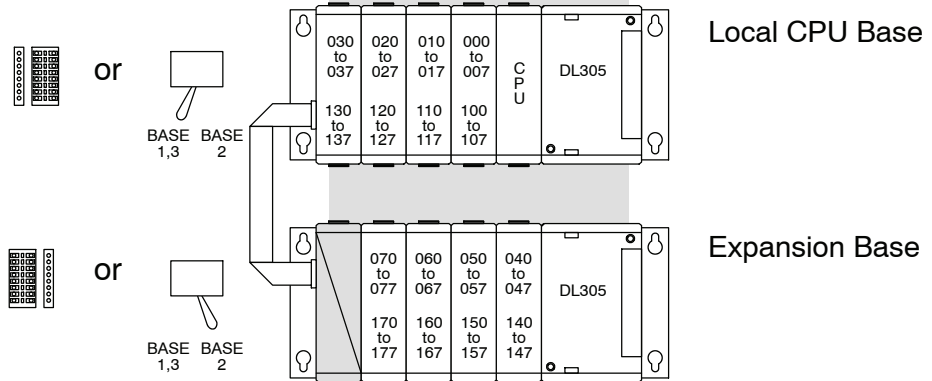

Example B

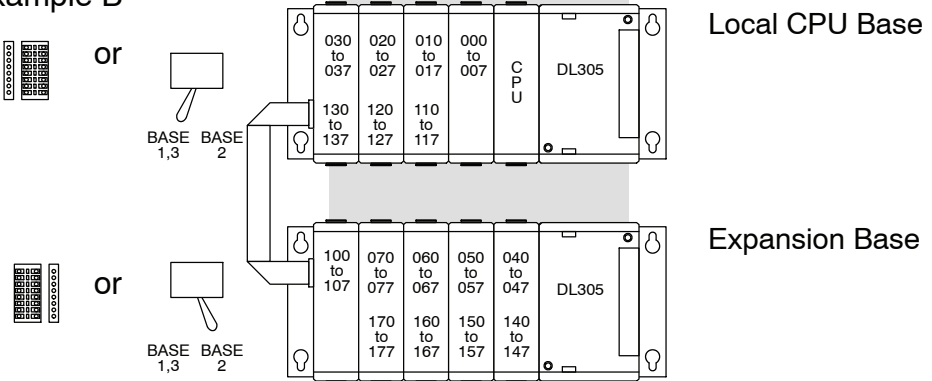

Examples Show Maximum I/O Points Available

For the following examples the configurations using 16 point I/O modules are shown with the maximum I/O points supported so you can always reduce the I/O count in one of our examples and the configuration will still be valid. Substitution of 8 point I/O modules can be made in place of any of the 16 point modules without affecting the I/O numbering for any of the other I/O modules. When a 16 point module is replaced with a 8 point I/O module the last 8 I/O addresses of that 16 point module may or may not be useable in another slot location, depending on the system configuration used

I/O Configurations with a 5 Slot Local CPU Base

The configurations below and on the next few pages show a 5 slot base with 8 point I/O modules, 16 point modules, one expansion base and two expansion bases.

Switch settings

The 5 slot base has a toggle switch or jumper on the inside of the base which allows you to select:

Type of Base	Switch Position convent. bases	Jumper Position xxxxx-1 bases
Local CPU	Base 1,3	right pins bridged
First Expansion	Base 2*	left pins bridged
Last Expansion	Base 1,3	right pins bridged

*used only with a 5 slot local CPU base

5 Slot Base with 8 Point I/O

Total I/O: 32



or

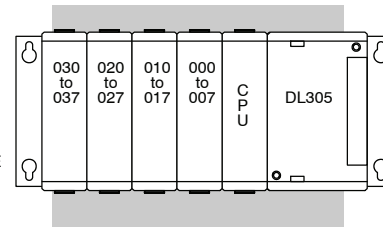
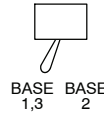

5 Slot Base with 16 Point I/O

Total I/O: 64



or

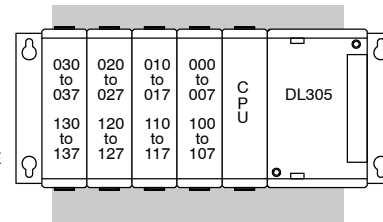
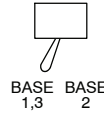

5 Slot Base and
5 Slot Expansion
Base with 8 Point
I/O

Total I/O: 72

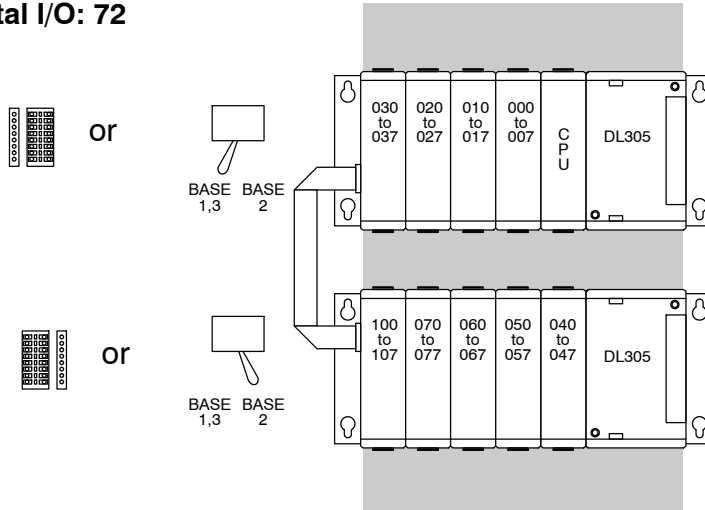

5 Slot Base and 5
Slot Expansion
Base with 16 Point
I/O

Total I/O: 128

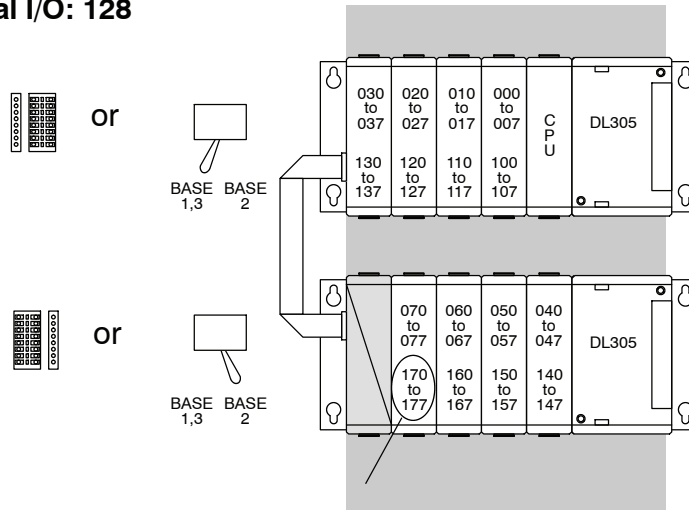

DL340 and DL350



NOTE: If a 16pt module is used in the last two available slots of the expansion base, 160 through 177 will not be available for control relay assignments. Also, even though you are using these points as I/O, you still enter them as C160-C177 in *DirectSOFT*.

5 Slot Base and Two 5 Slot Expansion Bases with 8 Point I/O

Total I/O: 112



or

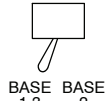

BASE BASE
1,3 2



or

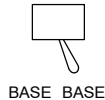

BASE BASE
1,3 2



or

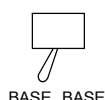

BASE BASE
1,3 2

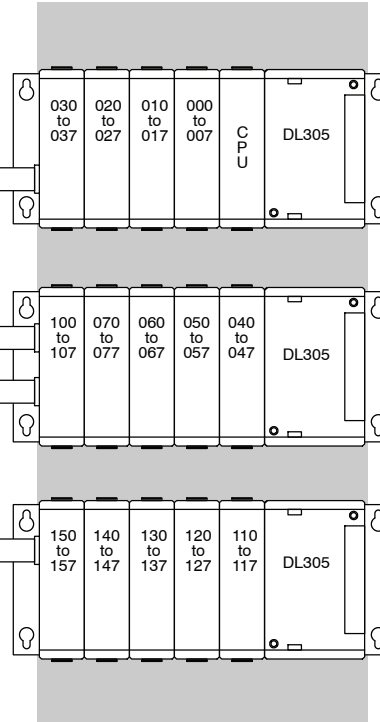

5 Slot Base and Two 5 Slot Expansion Bases with 16 and 8 Point I/O

Total I/O: 128



or

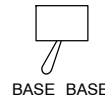

BASE BASE
1,3 2



or



BASE BASE
1,3 2

DL340 DL350



or

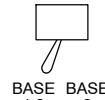

BASE BASE
1,3 2

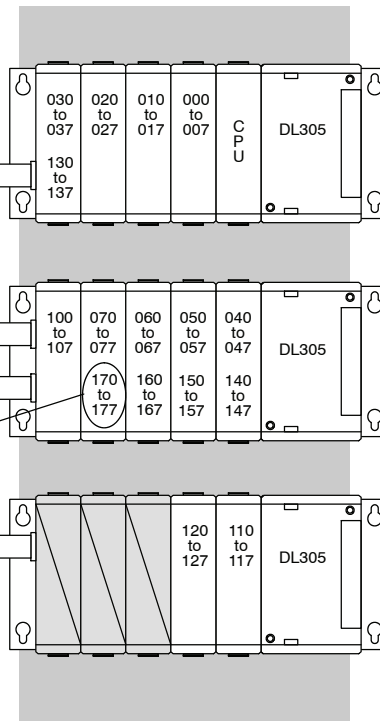

NOTE: If a 16pt module is used in the last two available slots of the expansion base, 160 through 177 will not be available for control relay assignments. Also, even though you are using these points as I/O, you still enter them as C160-C177 in *DirectSOFT*.

I/O Configurations with an 8 Slot Local CPU Base

The configurations below show an 8 slot base with 8 point I/O modules, 16 point modules, one 5 slot expansion base and two 5 slot expansion bases. Position of the jumper for xxx-1 bases is shown to the right of the base.

8 Slot Base with 8 Point I/O

Total I/O: 56

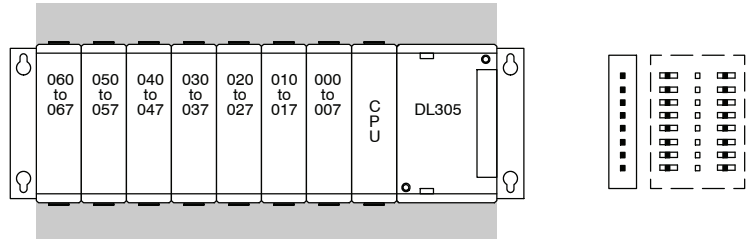

8 Slot Base with 16 Point I/O

Total I/O: 112

*See note below regarding points 160-167

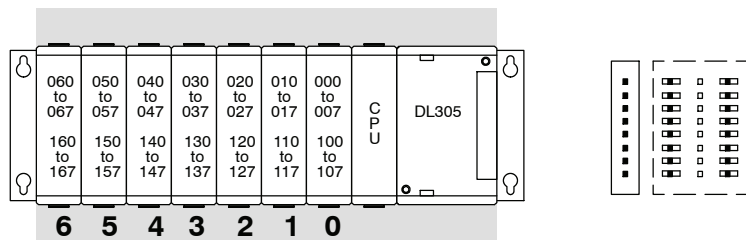

8 Slot Base and 5 Slot Expansion Base with 8 Point I/O

Total I/O: 96

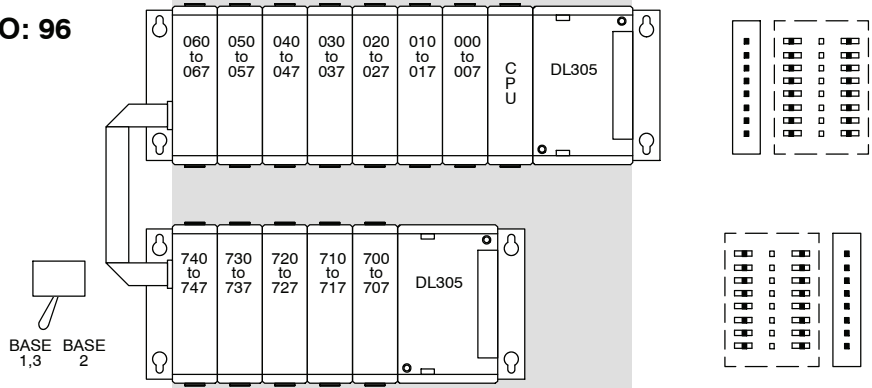

8 Slot Base and 5 Slot Expansion Base with 16 Point I/O

Total I/O: 152

*See note below regarding points 160-167

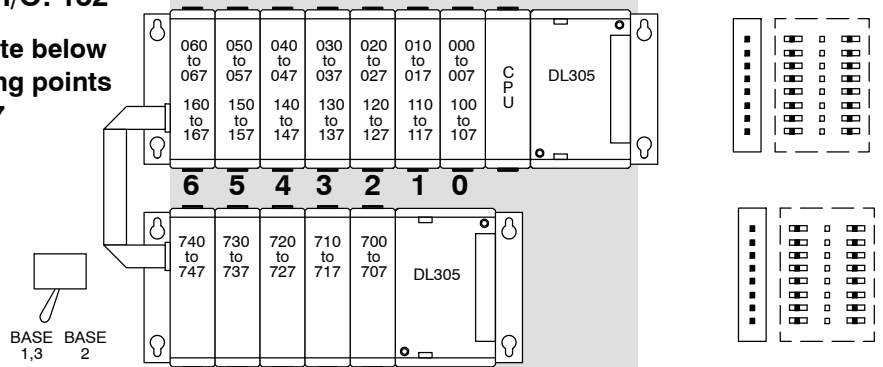

NOTE: If a 16pt module is used in the last two available slots of the expansion base, 160 through 177 will not be available for control relay assignments. Also, even though you are using these points as I/O, you still enter them as C160-C177 in *DirectSOFT*.

I/O Configurations with a 10 Slot Local CPU Base

The configurations below and on the next few pages show a 10 slot base with 8 point I/O modules, with 16 point modules, with a 5 slot expansion base and with a 10 slot expansion base.

Switch settings

The 10 slot base has two jumper switches to select the base type and the address ranges to use. These switches can be found on the base between slots 3 and 4 (SW1) and slots 9 and 10 (SW2). Jumper switch SW1 is used to select if the base is a local CPU base or an expansion base. Jumper switch SW2 determines the I/O address range (100 - 107 or 700 - 707) for the 10th slot on the local CPU base. By selecting the address range of 700 to 707 for slot 10, it is possible to use a 16 point module next to the CPU (which uses the ranges of 000 to 007 and 100 to 107), however; the position of this switch will affect the I/O numbering for the expansion I/O if used.



NOTE: Jumper switch SW2 must be set to "100 EXP" on the expansion base.

Last Slot Address Range 100 to 107

Total I/O: 72

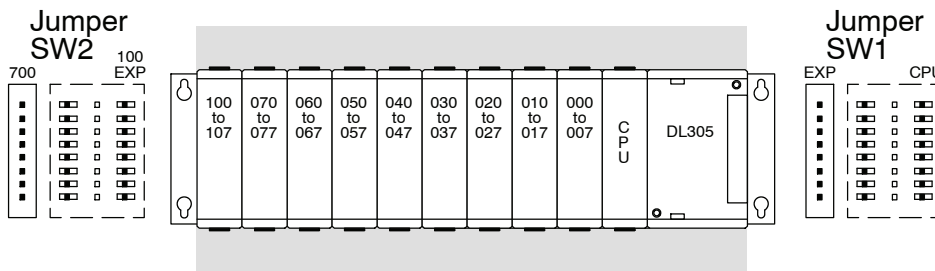

Last Slot Address Range 700 to 707

Total I/O: 72

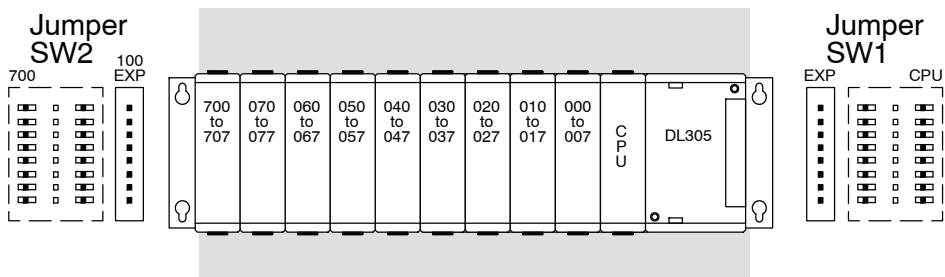

10 Slot Expansion Base with 16 Point I/O

The next two configurations show a local CPU base using 16 point I/O modules and the two possibilities for how to configure the base to use the maximum number of I/O points.

Configuration 1

Configuration 1 shows an 8 point I/O module the slot next to the CPU and the address range of 100–107 for the last slot. When jumper switch SW2 is set to the “100 EXP” position, the address range for the last slot is set to 100–107, thereby limiting the address range for the first module to 000–007. This means if you use this configuration, the first module must be an 8 point I/O module. You will have more available addresses for an expansion base as you will see in the example using a 10 slot expansion base.

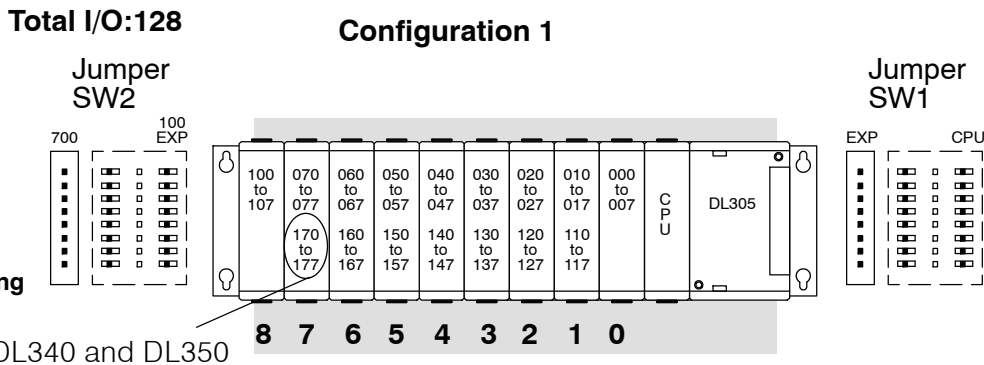

*See note below regarding points 160–167 and 170–177.

Configuration 2

Configuration 2 shows a 16 point I/O module in the slot next to the CPU and the address range of 700–707 for the last slot. This is the maximum I/O configuration for a 10 slot local CPU base. When jumper switch SW2 is set to the “700” position the address range for the last slot is set to 700–707 making addresses 000–007 and 100–107 available for use in the first slot. The position of jumper switch SW2 can limit the amount of I/O addresses available to the larger expansion bases since expansion I/O numbering would normally start with address 700.

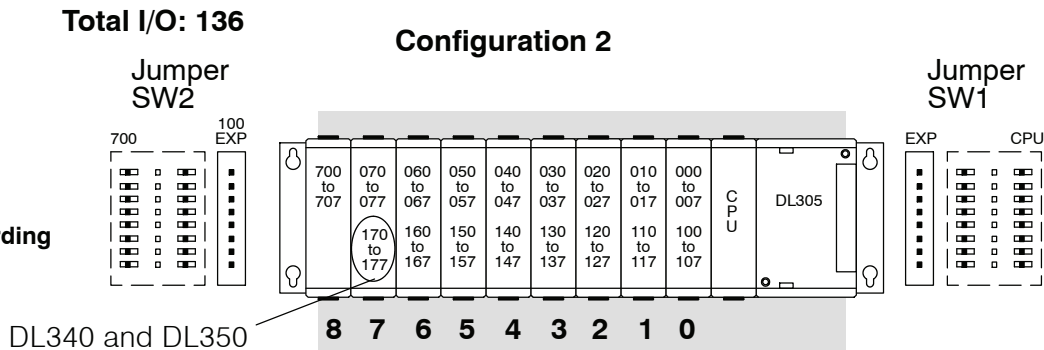

*See note below regarding points 160–167 and 170–177.



NOTE: If a 16pt module is used in Slot 6 for the DL330 or DL330P CPU, 160 through 167 will not be available for control relay assignments. If a 16pt module is used in Slot 6 and/or Slot 7 for a DL340 or DL350 CPU, 160–167 and/or 170–177 are not available for control relay assignments. Also, even though you are using these points as I/O, you still enter them as C160–C167/C170–C177 in **DirectSOFT**.

10 Slot Base and 5 Slot Expansion Base with 16 Point I/O

Total I/O: 176

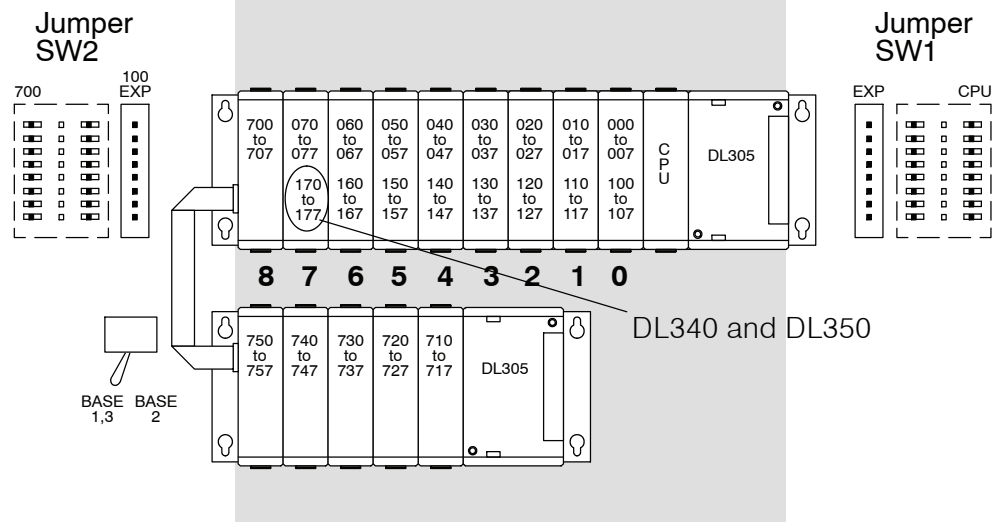

NOTE: If a 16pt module is used in Slot 6 for the DL330 or DL330P CPU, 160 through 167 will not be available for control relay assignments. If a 16pt module is used in Slot 6 and/or Slot 7 for a DL340 or DL350 CPU, 160-167 and/or 170-177 are not available for control relay assignments. Also, even though you are using these points as I/O, you still enter them as C160-C167/C170-C177 in **DirectSOFT**.

Expansion Addresses Depend on Local CPU Base Configuration.

I/O addresses change depending on the point configuration in the local CPU base. Notice, when the local CPU base contains only 8 point I/O modules, addresses 110-117, 120-127 and 130-137 are available for use in the expansion base. When the local CPU base has 16 point I/O modules, which use the I/O addresses 110-117, 120-127 and 130-137, these addresses are taken up and are not available for use in the expansion base.

10 Slot Base and 10 Slot Expansion Base with 8 Point I/O

Total I/O: 152

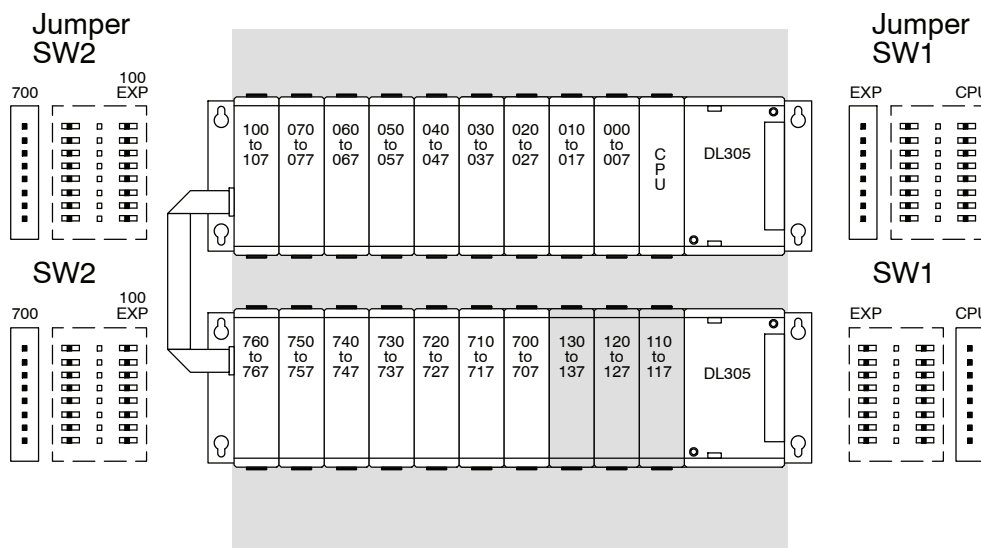

10 Slot Base and 10 Slot Expansion Base with 16 Point I/O

Total I/O: 184

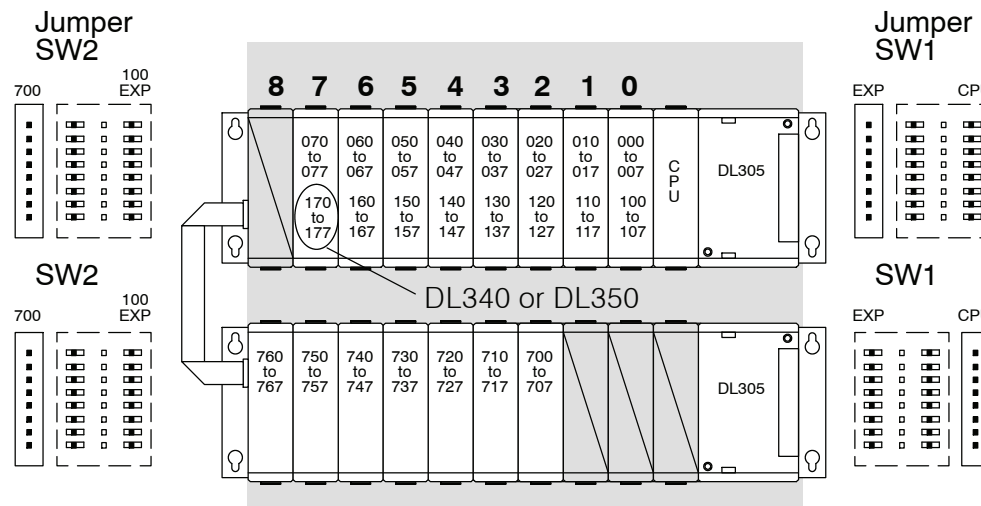

NOTE: If a 16pt module is used in Slot 6 for the DL330 or DL330P CPU, 160 through 167 will not be available for control relay assignments. If a 16pt module is used in Slot 6 and/or Slot 7 for a DL340 or DL350 CPU, 160-167 and/or 170-177 are not available for control relay assignments. Also, even though you are using these points as I/O, you still enter them as C160-C167/C170-C177 in **DirectSOFT**.

