

PLC MEMORY



In This Appendix...

DL205 PLC Memory.....	E-2
-----------------------	-----

DL205 PLC Memory

When designing a PLC application, it is important for the PLC user to understand the different types of memory in the PLC. The DL205 CPUs use two types of memory: RAM and EEPROM. RAM is Random Access Memory and EEPROM is Electrically Erasable Programmable Read Only Memory. The PLC program is stored in EEPROM, and the PLC V-memory data is stored in RAM. There is also a small range of V-memory that can be copied to EEPROM, which will be explained later.

The V-memory in RAM can be configured as either retentive or non-retentive.

Retentive memory is memory that is configured by the user to maintain values through a power cycle or a PROGRAM to RUN transition. Non-retentive memory is memory that is configured by the PLC user to clear data after a power cycle or a PROGRAM to RUN transition. The retentive ranges can be configured with either the Handheld Programmer using AUX57 or *DirectSOFT* (PLC > Setup).

The contents of RAM memory can be written to and read from an infinite number of times, but RAM requires a power source to maintain the contents of memory. The contents of RAM are maintained by the internal power supply (5VDC) only while the PLC is powered by an external source, normally 120VAC. When power to the PLC is turned off, the contents of RAM are maintained by a “Super-Capacitor.” If the Super-Capacitor ever discharges, the contents of RAM will be lost. In a D2-230 and D2-240 the data retention time of the Super-Capacitor backed RAM is 3 weeks maximum, and 4 1/2 days minimum (at 60°C). An optional battery, (ADC p/n D2-BAT), can be added to maintain RAM retentive memory if the D2-230 or D2-240 is ever without external power (see Volume I, page 3-14 for a detailed explanation).

In a D2-250-1 and D2-260, the Super-Capacitor backed RAM will be retained for 15.9 hours and in a D2-262, it is retained for 1.9 hours. The D2-260 uses a larger capacitor that provides current to the external real-time clock. The D2-262 has a smaller capacitor that provides current to the micro-processing unit with the integrated real-time clock, which results in the D2-262 hardware pulling more current and having less memory retention time. **Therefore, the purpose of the capacitor in the D2-262 is for exchanging the battery, not for memory retention.**

The contents of EEPROM memory can be read from an infinite number of times, but there is a limit to the number of times it can be written to (typical specification is 100,000 writes). EEPROM does not require a power source to maintain the memory contents. It will retain the contents of memory indefinitely.

PLC user V-memory is stored in both volatile RAM and non-volatile EEPROM memory. The table below shows the memory areas for each DL205 CPU.

DL205 Memory Area				
PLC Type	D2-230	D2-240	D2-250-1	D2-260/D2-262
Volatile RAM	V2000–V2377	V2000–V3777	V1400–V7377 V10000–V17777	V400–V777 V1400–V7377 V10000–V35777
Non-volatile	V4000–V4177	V4000–V4377	-	-

Data values that must be retained for long periods of time, when the PLC is powered off, should be stored in EEPROM-based V-memory. Since EEPROM is limited to the number of times it can be written to, it is suggested that transitional logic, such as a one-shot, be used to write the data one time, instead on each CPU scan.

Data values that are continually changing or which can be initialized with program logic should be stored in RAM-based V-memory.

Non-volatile V-memory in the DL205

Two types of memory are assigned for the non-volatile V-memory area: RAM and flash ROM (EEPROM). They are sharing the same V-memory addresses; however, **you can only use the MOV instruction, D2-HPP and DirectSOFT to write data to the flash ROM.** When you write data to the flash ROM, the same data is also written to RAM. If you use other instructions, you can only write data to RAM. When you read data from the non-volatile V-memory area, the data is always read from RAM. The following explanation uses the D2-240 CPU as an example.

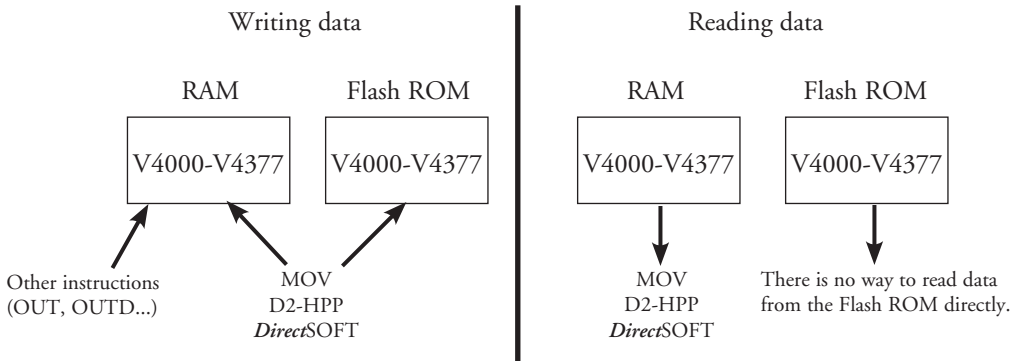

After a power cycle, the PLC always copies the data in the flash ROM to the RAM.

Appendix E: PLC Memory

If you use the instructions except for the MOV instruction to write data into the non-volatile V-memory area, you only update the data in RAM. After a power cycle, the PLC copies the previous data from the flash memory to the RAM, so you may think the data you changed has disappeared. To avoid trouble such as this, we recommend that you use the MOV instruction.

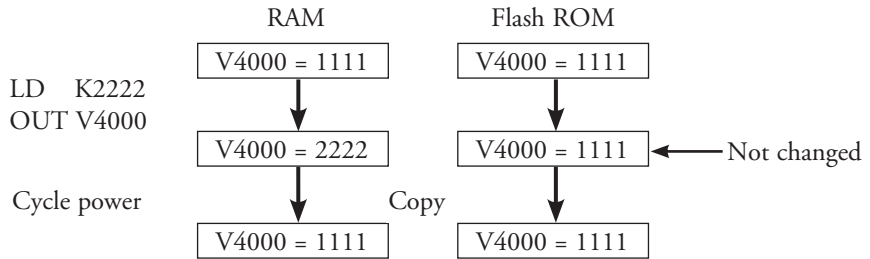

This appears to be previous data returning.

PLC Memory Processes

The following tables show how memory backup, memory restoration and retentive memory are handled by the D2-250-1, D2-260 and D2-262.

Backup

Moving SRAM to Flash ROM

- NO - Backup does not take place
- YES - see table below

Backup - Moving SRAM to Flash ROM						
	Power ON	RUN to STOP	STOP	RUN	User Memory	ScratchPad
D2-250-1 / D2-260	Yes	Yes	Yes	No	V7400-V7577	Yes
D2-262	No	Yes	Yes	No	V7620 – V7627 V7720 – V7722 V7630 – V7641 V7650 – V7656 V7740 – V7742	Yes

Restore

Moving Flash ROM to SRAM. Has a backup ever occurred:

- NO - restore does not take place
- YES - see table below

Restore - Moving Flash ROM to SRAM				
	Power ON	RUN to STOP	User Memory	ScratchPad
D2-250-1 / D2-260	Yes	No	V7400-V7577	Yes
D2-262	Yes	No	V7620 – V7627 V7720 – V7722 V7630 – V7641 V7650 – V7656 V7740 – V7742	Yes

Retentive Memory

Maintains SRAM during Power Off condition (battery installed)

Retentive Memory			
	Memory (if selected)	Capacitor Hold Time (No battery present)	Real Time Clock
D2-250-1 / D2-260	V0-V3777 T0-T377 CT0-CT377 C0-C3777 S0-S1777	~15 hours	External from CPU
D2-262	V0-V3777 T0-T377 CT0-CT377 C0-C3777 S0-S1777	~1.5 hours	Built-in CPU



WARNING: Super-capacitor provides enough time to change the battery, it is not meant to retain memory. Install the optional battery, D2-BAT-1, if you have concerns about losing retentive data.
