

Getting Started

1

In This Chapter. . . .

- Introduction
 - Conventions Used
 - Physical Characteristics
 - Analog Input Module Terminology
 - Analog Output Module Terminology
 - Selecting the Appropriate Module
 - Analog Made Easy - Four Simple Steps
-

Introduction

The Purpose of this Manual

This manual will show you how to select and install analog input and analog output modules. It also shows several ways to use the analog data in your PLC program. If you understand the DL205 instruction set and system setup requirements, this manual will provide the information you need to install and use the analog modules. This manual *is not* intended to be a tutorial on analog signal theory, but rather a user reference manual for the DL205 Analog I/O modules.



Supplemental Manuals

You may also want to have a copy of the DL205 User Manual (D2-USER-M) at hand when you are working with the analog modules. The DL205 User Manual is not absolutely necessary, but it does provide detailed descriptions of the instructions used to acquire the analog data. The User Manual also provides a more thorough description of how the I/O points are assigned to the module. Now, you have the material necessary to quickly understand the DL205 Analog I/O modules. So, let's get started!

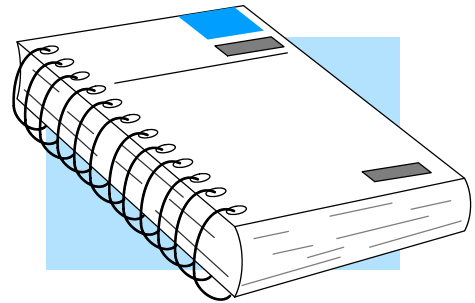

Technical Support

We realize that even though we strive to be the best, we may have arranged our information in such a way you cannot find what you are looking for. First, check these resources for help in locating the information:

- **Table of Contents** - chapter and section listing of contents, in the front of this manual
- **Appendices** - reference material for key topics, near the end of this manual

You can also check our online resources for the latest product support information:

- **Internet** - Our address is <http://www.automationdirect.com>

If you still need assistance, please call us at 770-844-4200. Our technical support group is glad to work with you in answering your questions. They are available Monday through Friday from 9:00 A.M. to 6:00 P.M. Eastern Standard Time. If you have a comment or question about any of our products, services, or manuals, please fill out and return the 'Suggestions' card that was shipped with this manual.

Conventions Used



When you see the “light bulb” icon in the left-hand margin, the paragraph to its immediate right will give you a **special tip**.
The word **TIP:** in boldface will mark the beginning of the text.



When you see the “notepad” icon in the left-hand margin, the paragraph to its immediate right will be a **special note**.
The word **NOTE:** in boldface will mark the beginning of the text.

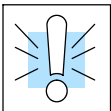

When you see the “exclamation mark” icon in the left-hand margin, the paragraph to its immediate right will be a **warning**. This information could prevent injury, loss of property, or even death (in extreme cases).
The word **WARNING:** in boldface will mark the beginning of the text.

Key Topics for Each Chapter

The beginning of each chapter will list the key topics that can be found in that chapter.

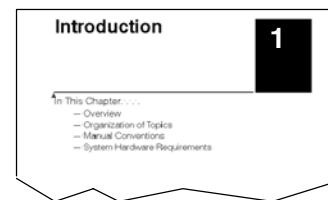

Physical Characteristics

The DL205 Analog Modules provide many features that make the modules easy to use. With the exception of the Thermocouple module, the terminal blocks are removable, which makes wiring a simple task.

All of the DL205 analog modules have normal screw terminal connectors. Access the module terminals by removing the front cover (not shown). To remove the front cover, press the tab on the lower front corner of the cover. For ease of removal, the terminal blocks have squeeze tabs on the top and bottom. To remove a terminal block, press the tabs and pull the terminal block away from the module.

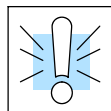

WARNING: For some modules, field device power may still be present on the terminal block even though the PLC system is turned off. To minimize the risk of electrical shock, check all field device power *before* you remove the connector.

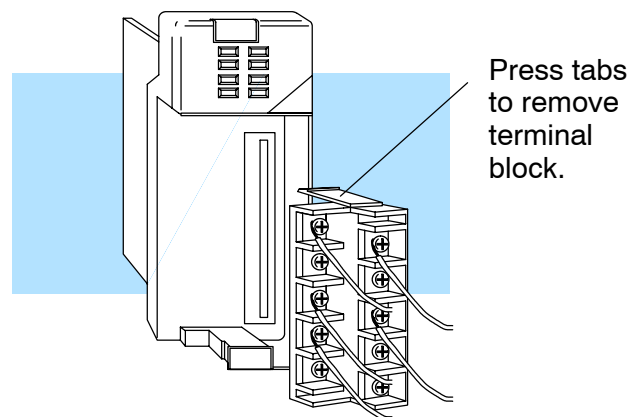

Analog Input Module Terminology

We use several different terms throughout the rest of this manual. You do not have to be an expert on analog terms to use the products, but it may help make it easier to select the appropriate modules if you take a few minutes to review these definitions.

Channels per Module	The total number of analog signals the module receives from field devices.
Input Ranges	The minimum to maximum spans in voltage or current the module will successfully convert to digital values.
Resolution	The number of binary weighted bits available on the digital side of the module for use in converting the analog value to a digital value.
Input Type	Specifies if the module accepts single ended, or differential input signals.
Input Impedance	The resistive load of the module as seen by a voltage or current input signal.
Conversion Method	The method the module uses to convert the analog signal to a digital value.
PLC Update Rate	Speed at which the analog signals are digitized and acknowledged in the PLC.
Linearity Error	The relative accuracy of the digital representation over the entire input range.
Maximum Inaccuracy	Maximum absolute error of the digital representation of the signal over the entire input range. Factors which contribute to maximum inaccuracy are also specified separately. These factors are full-scale calibration error, offset calibration error, and accuracy vs. temperature.
Accuracy vs. Temperature	The variations in the module's conversion accuracy with temperature over the module's operating temperature range.
I/O Points Required	The number of I/O points the CPU must dedicate to the module.
External Power Source	Some modules require a separate 12VDC or 24VDC power source. The 24VDC output supply at the local base can be used as long as you do not exceed the current ratings of 300mA.
Base Power Required	The amount of base current required by the module. Use this value in your power budget calculations.
Operating Temperature	The minimum and maximum temperatures the module will operate within.
Relative Humidity	The minimum and maximum humidity the module will operate within.
Step Response	The time required for an analog input to reach 95% of its final value at the converter following a step change in the input signal level.

Analog Output Module Terminology

Channels per Module	The total number of analog signals the module sends to field devices.
Output Ranges	The minimum to maximum spans in voltage or current the module outputs, converted from digital values.
Resolution	The number of binary weighted bits available on the digital side of the module for use in converting the digital value to an analog signal.
Output Current	The maximum current the module will drive using a voltage output signal.
Output Impedance	The output impedance of the module using a voltage output signal.
Load Impedance	The minimum and maximum resistance the module can drive, specified for current and voltage output signals.
PLC Update Rate	The speed at which digital values in the PLC are converted to analog output signals.
Linearity Error	The relative accuracy of the digital representation over the entire output range.
Maximum Inaccuracy	Maximum absolute error of the digital representation of the signal over the entire output range. Factors which contribute to maximum inaccuracy are also specified separately. These factors are full-scale calibration error, offset calibration error, and accuracy vs temperature.
Accuracy vs. Temperature	The variations in the module's conversion accuracy with temperature over the module's operating temperature range.
External Power Source	All output modules contain circuitry which is optically isolated from PLC-side logic. That circuitry requires field-side power from a separate 24VDC power source. The 24VDC output supply at the local base can be used as long as you do not exceed the current ratings.
Base Power Required	The amount of base current required by the module. Use this value in your power budget calculations.
Operating Temperature	The minimum and maximum temperatures the module will operate within.
Relative Humidity	The range of air humidity over which the module will operate properly.
I/O Points Required	The number of I/O points the CPU must dedicate to the module.

Selecting the Appropriate Module

Wide Variety of Modules

There are a wide variety of Analog I/O modules available for use with the DL205 family of automation products. These modules are well suited for monitoring and controlling various types of analog signals such as pressure, temperature, etc. No complex programming or module setup software is required. Simply install the module, add a few lines to your RLL program, and you're ready!

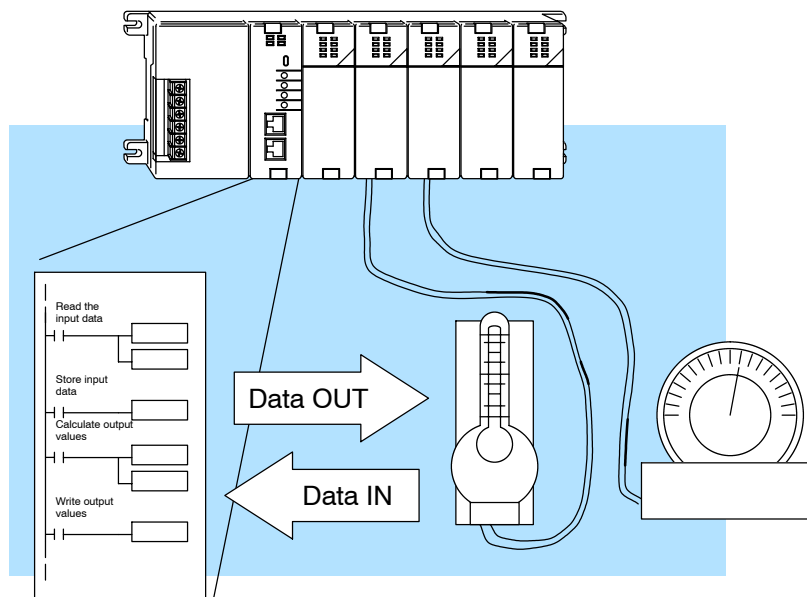

Analog input, temperature input and analog output modules are available. These modules are designed and manufactured by FACTS Engineering. FACTS has been producing feature-packed products for the **Direct**LOGIC families (and compatible products) for years! These modules are readily identifiable by their F2- prefix in the part number.

Diagnostic Features

The DL205 Analog Modules use an on-board microcontroller that automatically monitors module diagnostics. You can easily detect missing field-side supply 24 VDC voltage or a loose terminal block.

The following tables provide a condensed version of the information you need to select the appropriate module. The most important thing is to simply determine the number of channels required and the signal ranges that must be supported. Once you've determined these parameters, look in the specific chapter for the selected module to determine the installation and operation requirements.

Analog Input

Specification	F2-04AD-1, (L)	F2-04AD-2, (L)	F2-08AD-1	F2-08AD-2
Channels	4	4	8	8
Input Ranges	4 - 20 mA	0 - 5V, 0 - 10V, -5 to +5V, -10 to +10V	4 - 20 mA	0 - 5V, 0 - 10V, -5 to +5V, -10 to +10V
Resolution	12 bit (1 in 4096)	12 bit (1 in 4096), and 13 bit (1 in 8192)	12 bit (1 in 4096)	12 bit (1 in 4096), and 13 bit (1 in 8192)
Input Type	Single ended	Single ended	Single ended	Single ended
Maximum Inaccuracy	$\pm 0.5\%$ at 25 °C (77 °F), $\pm 0.65\%$ at 0° - 60° C (32° - 140° F)	$\pm 0.1\%$ at 25 °C (77 °F), $\pm 0.3\%$ at 0° - 60° C (32° - 140° F)	$\pm 0.1\%$ at 25 °C (77 °F), $\pm 0.25\%$ at 0° - 60° C (32° - 140° F)	$\pm 0.1\%$ at 25 °C (77 °F), $\pm 0.3\%$ at 0° - 60° C (32° - 140° F)
See Chapter...	2	3	4	5

Special Input

Specification	F2-04RTD	F2-04THM
Input Channels	4	4
Resolution	16 bit internal	16 bit voltage ranges 24 bit Internal
Input Ranges	Pt100 Ω , -200.0 - 850.0 °C (-328 - 1562 °F) Pt1000 Ω , -200.0 - 595.0 °C (-328 - 1103 °F) jPt100 Ω , -38.0 - 450.0 °C (-36 - 842 °F) Cu. 25 Ω , Cu. 10 Ω -200.0 - 260.0 °C (-328 - 500 °F)	Type J -190 - 760°C E -210 - 1000°C K -150 - 1372°C R 65 - 1768°C S 65 - 1768°C T -230 - 400°C B 529 - 1820°C N -70 - 1300°C C 65 - 2320°C Voltage Ranges 0-5 VDC \pm 5 VDC 0-156mVDC \pm 156mVDC
Input Type	Differential	Differential
Maximum Input Inaccuracy	$\pm 1.0^\circ\text{C}$	$\pm 3.0^\circ\text{C}$ Temperature $\pm 0.02\%$ Voltage
See Chapter...	6	7

Analog Output

Specification	F2-02DA-1, (L)	F2-02DA-2, (L)
Channels	2	2
Output Ranges	4 - 20 mA	0 - 5V, 0 - 10V, -5 to +5V, -10 to +10V
Resolution	12 bit (1 in 4096)	12 bit (1 in 4096)
Output Type	Single ended	Single ended
See Chapter...	8	9

Specification	F2-08DA-1	F2-08DA-2
Channels	8	8
Output Ranges	4 - 20mA	0 - 5V, 0 - 10V
Resolution	12 bit (1 in 4096)	16 bit (1 in 4096)
Output Type	Single ended	Single ended, 1 common
See Chapter...	10	11

Specification	F2-02DAS-1	F2-02DAS-2
Channels	2	8
Output Ranges	4 - 20mA	0 - 5V, 0 - 10V
Resolution	16 bit (1 in 65536)	16 bit (1 in 65536)
Output Type	Current sourcing	Isolated
See Chapter...	12	13

Combination
Analog

Specification	F2-4AD2DA
Input Channels	4
Output Channels	2
Input Ranges	4 - 20 mA
Output Ranges	4 - 20 mA
Resolution	12 bit (1 in 4096)
Channel Isolation	Non-isolated (one common)
Input and Output Types	Single ended
Maximum Input Inaccuracy	$\pm 0.3\%$ at 25 °C (77 °F) $\pm 0.45\%$ at 0° - 60° C (32° - 140° F)
Maximum Output Inaccuracy	$\pm 0.1\%$ at 25 °C (77 °F) $\pm 0.3\%$ at 0° - 60° C (32° - 140° F)
See Chapter	14

Analog Made Easy - Four Simple Steps

Once you have selected the appropriate module, use the chapter that describes that module and complete the following steps.

Step 1. Take a minute to review the detailed specifications to make sure the module meets your application requirements.

Specification		
Channels	2	2
Output Ranges	4 - 20 mA	0 - 5V 0 - 10V -5 - +5V -10 - +10V
Resolution	12 bit (1 in 4096)	12 bit (1 in 4096)
Channel Isolation	Non-isolated	Non-isolated
Output Type	Single ended	Single ended
Maximum Inaccuracy at 25 °C (77 °F)	± 0.1%	± 0.3% unipolar ± 0.4% bipolar
at 0° - 25° C (32° - 140° F)	± 0.3%	
See Chapter . . .	4	5

Step 2. If applicable, set the module switches and/or jumpers to select:

- number of channels
- the operating ranges

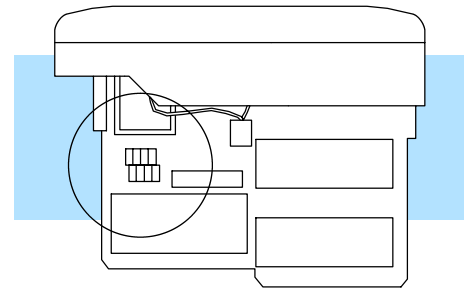

Step 3. Connect the field wiring to the module connector.

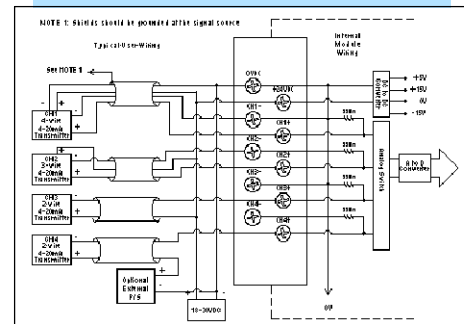

Step 4. Review the module operating characteristics and write the control program.

